

SoundBeast[®] All-In-One Vintage-Style Turntable *(Model TT25)*

Quick Start Guide & User's Manual



5-Year Warranty +

FREE USA-Based Support

For customer support, email us at:

support@soundbeast.rocks

Extend your warranty to 6 years for free by registering at:

www.SoundBeast.rocks/register/

SOUNDBEAST[®]

www.SoundBeast.rocks

Extend Your Warranty for FREE!

Extend your warranty by one year for free simply by registering your product at: www.SoundBeast.rocks/register/

Thank You!

Thank you for your purchase of the SoundBeast® All-In-One Vintage-Style Turntable (TT25)! We appreciate your business.

If you have any issues, please contact our USA-based customer support at support@soundbeast.rocks

(Make sure you explain your issue in detail and tell us that you're using our SoundBeast® All-In-One Vintage-Style Turntable, Model TT25). Our USA-based support team members will normally reply to you within 24-48 business hours, usually sooner.)

Safety Instructions – Please Read & Follow

WARNING: DO NOT EXPOSE THIS APPLIANCE TO RAIN OR MOISTURE.

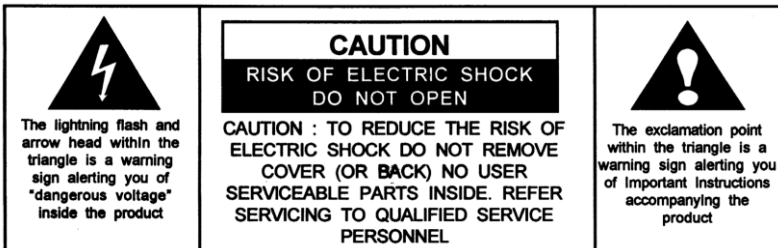

Safety Instructions (Continued)

1. **!! NORTH AMERICAN VOLTAGE ONLY!! Outside North America, this product requires a voltage transformer. Using this device with voltage over 120V will instantly destroy the device.**
2. Keep these instructions.
3. Heed all Warnings.
4. Follow all instructions and do NOT allow children around this device.
5. Do not use this apparatus near water or spill liquids on it.
6. Clean only with a dry cloth.
7. Do not block any ventilation openings. Install in accordance with the manufacturer's instructions.
8. Do not install near any sources such as radiators, heat registers, stoves, or other apparatus (including amplifiers) that produce heat.
9. Do not defeat the safety purpose of the polarized or grounding –type plug. A polarized plug has two blades with one wider than the other. A grounding type plug has two blades and a third grounding prong. The wide blade or the third prong are provided for your safety. When the provided plug does not fit into your outlet, consult an electrician for replacement of the obsolete outlet.
10. Protect the power cord from being walked on or pinched particularly at plug, convenience receptacles, and the point where they exit from the apparatus.
11. Only use attachments/accessories specified by the manufacturer.
12. Unplug this apparatus during lightning storms or when unused for long periods of time.
13. Refer all servicing to qualified service personnel. Servicing is required when the apparatus has been damaged in any way, such as power-supply cord or plug is damaged, liquid has been LED or objects have fallen into the apparatus, the apparatus has been exposed to rain or moisture, does not operate normally, or has been dropped.

QUICK START – Setting Up The Device

1. Securely plug the power plug into a power outlet.

!! Important Note For Users Outside USA, Canada, and Mexico !! *This device is ONLY compatible with standard North American 110V-120V voltage. DO NOT USE WITH VOLTAGES OVER 110V-120V, as this will instantly and permanently damage the device!*

2. Turn on the device by pushing the “VOLUME” (right) knob inward.
3. Set the “MODE” (left) knob to the desired function.

QUICK START – Listening To AM/FM Radio

1. Turn on the device by pressing the “VOLUME” (right) knob inward.
2. Set the “MODE” (left) knob to “AM” or “FM.”
3. Rotate the “TUNING” knob to set the desired radio station. The blue indicator light will change to pink when a radio station is detected.
4. Use the volume control knob to adjust the volume.

Note: Do not connect an external antenna to the unit.

QUICK START – Playing Records

1. Turn on the device by pressing the “VOLUME” (right) knob inward.
2. Set the “MODE” (left) knob to “PHONO.”
3. Set the SPEED SELECTOR to 33, 45 or 78 RPM according to the speed of the record.
4. Remove the stylus guard of the tone arm and place the tone arm on the record carefully.
5. Use the volume control knob to adjust the volume.

At the end of record, lift up the tone arm and return it to tone arm rest carefully.

QUICK START – Playing CDs

1. Turn on the device by pressing the “VOLUME” (right) knob inward.
2. Set the “MODE” (left) knob to “CD.”
3. Press the OPEN/CLOSE button to open the CD door.
4. Place a CD in the tray with the labeled side facing up.
5. Press the OPEN/CLOSE button again to close the CD

door.

6. Press the PLAY/PAUSE button to start playback.
7. To pause playback, press the PLAY/PAUSE button.
Press the PLAY/PAUSE button again to resume playback.
8. To stop playback, press the STOP button.
6. Use the volume control knob to adjust the volume.
7. To repeat a single track, choose the track that you want to repeat, then press the PLAY BUTTON to start the track. Press the REPEAT BUTTON once to repeat this track.
8. To repeat all tracks, press the REPEAT twice to repeat all tracks. Once the CD ends, it will start over again from the beginning of the CD.

QUICK START – Playing Cassette Tapes

1. Turn on the device by pressing the “VOLUME” (right) knob inward.
2. Set the “MODE” (left) knob to “TAPE.”
3. Insert a tape into the cassette slot (right side of device).
Ensure the tape is fully inserted in the slot.
4. The tape will automatically start playing. Use the volume

control knob to adjust the volume.

5. To fast forward, HALFWAY press the eject button on the cassette tape slot. To stop fast forwarding, repeat this process.
6. To stop and eject the cassette tape, press the eject button on the cassette tape slot completely.
7. When one side of the tape finishes playing, the cassette will automatically stop.

NOTE: Remove the tape from the unit when it is not in use or stopped.

QUICK START – Playing Music via Bluetooth

1. Turn on the device by pressing the “VOLUME” (right) knob inward.
2. Set the “MODE” (left) knob to “BT.”
3. On your phone, tablet, or computer, search for the Bluetooth device named “SoundBeast TT25.” Connect to this device.
4. Start playing music on your phone, tablet, or computer.

5. Use the volume control knob on the turntable to adjust the volume. (Note: You may also need to adjust the volume on your phone or tablet.)

QUICK START – Playing Music via USB Drive or SD Card

1. Turn on the device by pressing the “VOLUME” (right) knob inward.
2. Set the “MODE” (left) knob to “USB” or “CARD.”
3. Plug in a USB drive or SD card that contains music files (MP3, APE, FLAC, WAV and WMA files). **NOTE: The USB drive must be 64GB or less and formatted as exFAT/FAT32.**
4. The turntable will start playing tracks from the USB drive or SD card. Use the volume control knob on the turntable to adjust the volume.
5. To pause playback, press the PLAY/PAUSE button. Press the PLAY/PAUSE button again to resume playback. To stop playback, press the STOP button.
6. Press the FORWARD SKIP BUTTON to skip next track. Press the BACKWARD SKIP BUTTON to skip previous

track.

7. To repeat a single track, choose the track that you want to repeat, then press the PLAY BUTTON to start the track. Press the REPEAT BUTTON once to repeat this track.
8. To repeat all tracks, press the REPEAT twice to repeat all tracks. Once the USB ends, it will start over again from the beginning of the USB.

QUICK START – Recording Music to USB Drive

1. Plug in a USB drive into the USB slot. **NOTE: The USB drive must be 64GB or less and formatted as exFAT/FAT32.**
2. Turn the MODE (left) knob to select a mode (such as PHONO or FM).
3. Press the MODE (left) knob inward to start recording.
4. The device will record music to the USB drive.
5. To stop recording, press the MODE (left) knob inward again.
6. After you stop recording, the files will be saved in files in a folder marked “RECORD” on the USB drive.
7. **NOTE: Do not switch modes while recording. Do not remove the USB drive until you stop recording.**

PROGRAMMED PLAYBACK (CDs)

(Advanced Feature)

1. Press the PROGRAM BUTTON in “CD” mode (with CD stopped playing). **P01** will be shown on display.
2. Press the FORWARD SKIP BUTTON ►► or BACKWARD SKIP BUTTON ◄◄ to select the tracks.
3. Press the PROGRAM BUTTON again to store the selected track number.
4. Repeat step 2 and 3 above to program other tracks.
5. Press the PLAY/PAUSE button to start programmed playback.
6. To erase the programmed sequence, press the STOP button twice, **OR** the programmed tracks will also erase when the CD DOOR is opened.

Device Diagram & Features

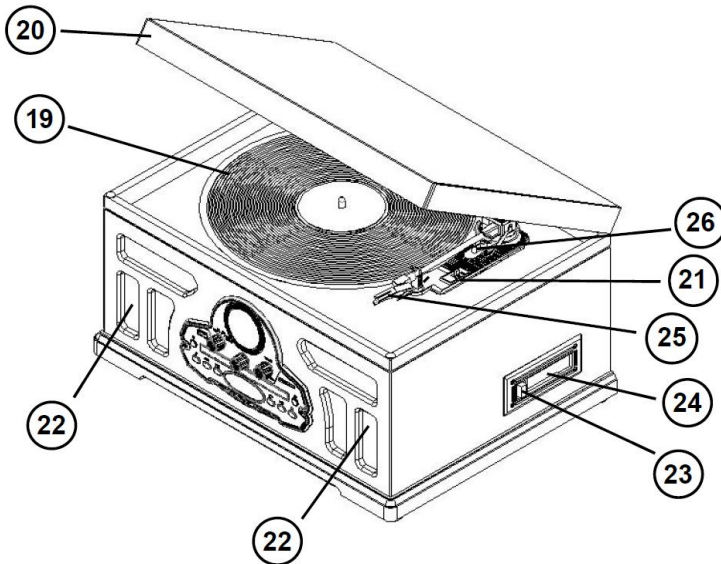
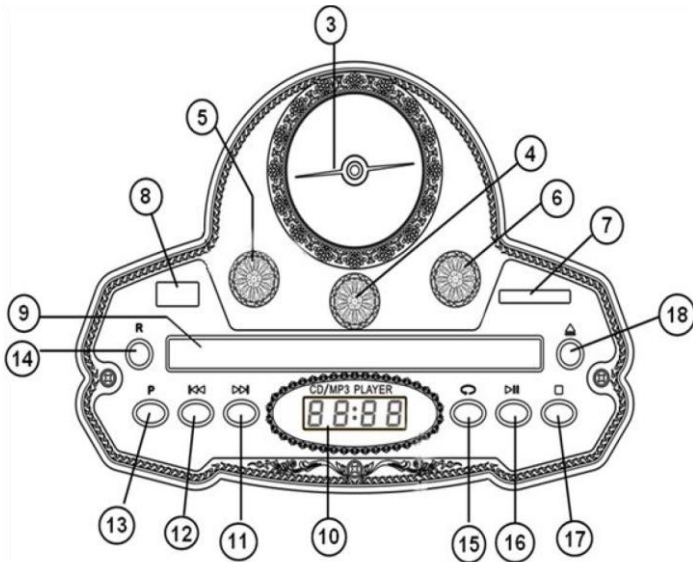

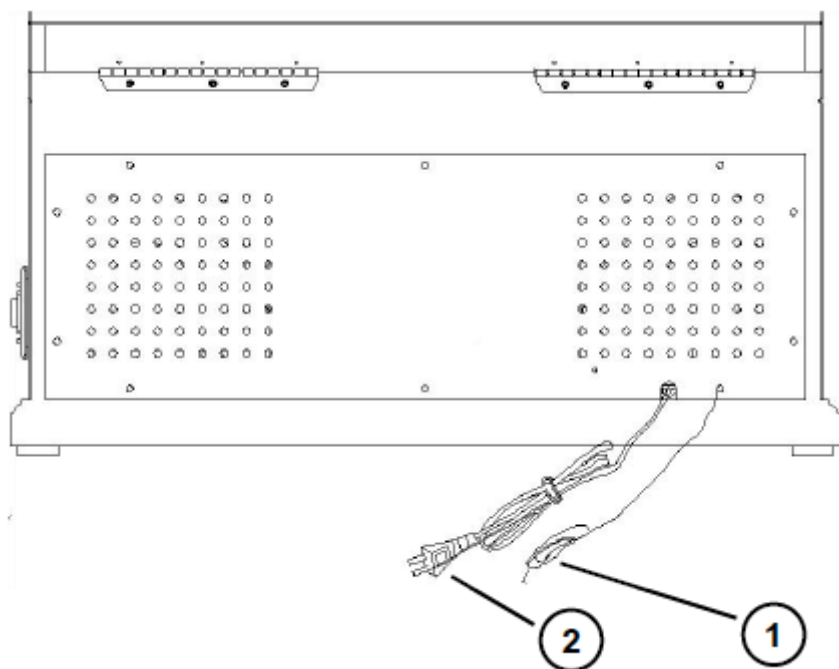

1. FM WIRE ANTENNA
2. AC POWER CORD
3. RADIO POINTER
4. TUNING CONTROL
5. MODE/REC
6. ON/OFF VOLUME CONTROL
7. SD JACK
8. USB JACK
9. CD DRAWER
10. CD TRACK DISPLAY
11. CD F.FWD.
12. CD REW
13. CD PROGRAM/COPY
14. CD RANDOM
15. CD REPEAT
16. CD PLAY/PAUSE
17. CD STOP
18. CD OPEN BUTTON
19. TURNTABLE
20. TURNTABLE LID
21. SPEED SELECTOR (33 $\frac{1}{3}$ /45/78)
22. SPEAKER
23. CASSETTE EJECT/FAST FORWARD
24. CASSETTE SLOT
25. STYLUS GUARD
26. TONEARM REST

Troubleshooting

1. The USB function isn't working.

Make sure your USB drive contains files in the following formats: MP3, APE, FLAC, WAV and WMA files.

Make sure your USB drive is 64GB or less. NOTE: The USB drive must be formatted as exFAT/FAT32. NTFS not supported.

2. In Bluetooth mode, the turntable's volume is turned up all the way, but the sound isn't loud enough.

Make sure you have turned up the volume on your phone, tablet, or MP3 player as well.

3. I need further assistance or information on the product's warranty.

Just email us at support@soundbeast.rocks, and we'll get right back to you! If you haven't heard back from us within 1-2 business days, please check your "Spam" folder in your email.

FCC Statement

Changes or modifications not expressly approved by the party responsible for compliance could void the user's authority to operate the equipment. This equipment has been tested and found to comply with the limits for a Class B digital device, pursuant to Part 15 of the FCC Rules. These limits are designed to provide reasonable protection against harmful interference in a residential installation. This equipment generates, uses, and can radiate radio frequency energy and, if not installed and used in accordance with the instructions, may cause harmful interference to radio communications. However, there is no guarantee that interference will not occur in a particular installation. If this equipment does cause harmful interference to radio or television reception, which can be determined by turning the equipment off and on, the user is encouraged to try to correct the interference by one or more of the following measures:

- Reorient or relocate the receiving antenna.
- Increase the separation between the equipment and receiver.
- Connect the equipment into an outlet on a circuit different from that to which the receiver is connected.
- Consult the dealer or an experienced radio/TV technician for help.

This device complies with part 15 of the FCC rules. Operation is subject to the following two conditions: (1) This device may not cause harmful interference, and (2) This device must accept any interference received, including interference that may cause undesired operation.

SOUNDBEAST[®]

www.SoundBeast.rocks

support@soundbeast.rocks