



FCC RADIO TEST REPORT

FCC ID : 2ASD3-7878
Equipment : Digital Media Receiver
Model name : C77A68
Applicant : H.C. China X LLC
3450 N. Triumph Blvd., Suite 102
Lehi, Utah 84043
Standard : FCC Part 15 Subpart E §15.407

The product was received on Apr. 15, 2019 and testing was started from Jul. 06, 2019 and completed on Aug. 08, 2019. We, SPORTON INTERNATIONAL INC., EMC & Wireless Communications Laboratory, would like to declare that the tested sample has been evaluated in accordance with the test procedures and has been in compliance with the applicable technical standards.

The report must not be used by the client to claim product certification, approval, or endorsement by TAF or any agency of government.

The test results in this report apply exclusively to the tested model / sample. Without written approval of SPORTON INTERNATIONAL INC. EMC & Wireless Communications Laboratory, the test report shall not be reproduced except in full.

Louis Wu

Approved by: Louis Wu

SPORTON INTERNATIONAL INC. EMC & Wireless Communications Laboratory
No. 52, Huaya 1st Rd., Guishan Dist., Taoyuan City, Taiwan (R.O.C.)



Table of Contents

History of this test report.....	3
Summary of Test Result.....	4
1 General Description	5
1.1 Product Feature of Equipment Under Test.....	5
1.2 Product Specification of Equipment Under Test.....	5
1.3 Modification of EUT	5
1.4 Testing Location	6
1.5 Applicable Standards.....	6
2 Test Configuration of Equipment Under Test	7
2.1 Carrier Frequency and Channel	7
2.2 Test Mode.....	8
2.3 Connection Diagram of Test System.....	9
2.4 Support Unit used in test configuration and system	10
2.5 EUT Operation Test Setup	10
2.6 Measurement Results Explanation Example.....	10
3 Test Result	11
3.1 6dB and 26dB and 99% Occupied Bandwidth Measurement	11
3.2 Maximum Conducted Output Power Measurement	14
3.3 Power Spectral Density Measurement	15
3.4 Unwanted Emissions Measurement.....	17
3.5 AC Conducted Emission Measurement.....	22
3.6 Automatically Discontinue Transmission	24
3.7 Antenna Requirements.....	26
4 List of Measuring Equipment.....	27
5 Uncertainty of Evaluation.....	29
Appendix A. Conducted Test Results	
Appendix B. AC Conducted Emission Test Result	
Appendix C. Radiated Spurious Emission	
Appendix D. Radiated Spurious Emission Plots	
Appendix E. Duty Cycle Plots	



History of this test report

Report No.	Version	Description	Issued Date
FR941514-01F	01	Initial issue of report	Aug. 27, 2019



Summary of Test Result

Report Clause	Ref Std. Clause	Test Items	Result (PASS/FAIL)
3.1	15.403 (i)	6dB & 26dB Bandwidth	Pass
3.1	2.1049	99% Occupied Bandwidth	Reporting only
3.2	15.407 (a)	Maximum Conducted Output Power	Pass
3.3	15.407 (a)	Power Spectral Density	Pass
3.4	15.407(b)	Unwanted Emissions	Pass
3.5	15.207	AC Conducted Emission	Pass
3.6	15.407 (c)	Automatically Discontinue Transmission	Pass
3.7	15.203 & 15.407 (a)	Antenna Requirement	Pass

Declaration of Conformity:

The test results with all measurement uncertainty excluded are presented in accordance with the regulation limits or requirements declared by manufacturers.

Comments and Explanations:

The declared of product specification for EUT presented in the report are provided by the manufacturer, and the manufacturer takes all the responsibilities for the accuracy of product specification.

Reviewed by: Wii Chang**Report Producer: Ann Lee**



1 General Description

1.1 Product Feature of Equipment Under Test

Product Feature	
Equipment	Digital Media Receiver
Model Name	C77A68
FCC ID	2ASD3-7878
EUT supports Radios application	WLAN 11b/g/n HT20 WLAN 11a/n HT20/HT40 WLAN 11ac VHT20/VHT40/VHT80 Bluetooth BR/EDR/LE

1.2 Product Specification of Equipment Under Test

Standards-related Product Specification	
Tx/Rx Channel Frequency Range	5745 MHz ~ 5825 MHz
Maximum Output Power	802.11a : 18.40 dBm / 0.0692 W 802.11n HT20 : 18.10 dBm / 0.0646 W 802.11n HT40 : 19.90 dBm / 0.0977 W 802.11ac VHT20: 18.00 dBm / 0.0631 W 802.11ac VHT40: 19.80 dBm / 0.0955 W 802.11ac VHT80: 18.00 dBm / 0.0631 W
99% Occupied Bandwidth	802.11a : 16.83 MHz 802.11n HT20 : 17.83 MHz 802.11n HT40 : 37.86 MHz 802.11ac VHT80 : 78.96 MHz
Antenna Gain / Gain	PCB Loop Antenna with gain 6.0 dBi
Type of Modulation	802.11a/n : OFDM (BPSK / QPSK / 16QAM / 64QAM) 802.11ac : OFDM (BPSK/QPSK/16QAM/64QAM/256QAM)

1.3 Modification of EUT

No modifications are made to the EUT during all test items.



1.4 Testing Location

Test Site	SPORTON INTERNATIONAL INC. EMC & Wireless Communications Laboratory		
Test Site Location	No.52, Huaya 1st Rd., Guishan Dist., Taoyuan City, Taiwan (R.O.C.) TEL: +886-3-327-3456 FAX: +886-3-328-4978		
Test Site No.	Sporton Site No.		
	TH05-HY	CO05-HY	DFS02-HY

Note: The test site complies with ANSI C63.4 2014 requirement.

Test Site	SPORTON INTERNATIONAL INC. EMC & Wireless Communications Laboratory		
Test Site Location	No.58, Aly. 75, Ln. 564, Wenhua 3rd, Rd., Guishan Dist., Taoyuan City, Taiwan (R.O.C.) TEL: +886-3-327-0868 FAX: +886-3-327-0855		
Test Site No.	Sporton Site No.		
	03CH11-HY		

Note: The test site complies with ANSI C63.4 2014 requirement.

FCC designation No.: TW1190 and TW0007

1.5 Applicable Standards

According to the specifications of the manufacturer, the EUT must comply with the requirements of the following standards:

- ♦ FCC Part 15 Subpart E
- ♦ FCC KDB 789033 D02 General UNII Test Procedures New Rules v02r01.
- ♦ FCC KDB 414788 D01 Radiated Test Site v01r01.
- ♦ ANSI C63.10-2013

Remark:

1. All test items were verified and recorded according to the standards and without any deviation during the test.
2. This EUT has also been tested and complied with the requirements of FCC Part 15, Subpart B, recorded in a separate test report.



2 Test Configuration of Equipment Under Test

- a. The EUT has been associated with peripherals and configuration operated in a manner tended to maximize its emission characteristics in a typical application. Frequency range investigated: conduction emission (150 kHz to 30 MHz), radiation emission (9 kHz to the 10th harmonic of the highest fundamental frequency or to 40 GHz, whichever is lower). For radiated measurement, pre-scanned in three orthogonal panels, X, Y, Z. The worst cases (Y plane) were recorded in this report.

- b. AC power line Conducted Emission was tested under maximum output power.

2.1 Carrier Frequency and Channel

Frequency Band	Channel	Freq. (MHz)	Channel	Freq. (MHz)
5725-5850 MHz Band 4 (U-NII-3)	149	5745	157	5785
	151*	5755	159*	5795
	153	5765	161	5805
	155#	5775	165	5825

Note:

- 1. The above Frequency and Channel in "*" were 802.11n HT40 and 802.11ac VHT40.
- 2. The above Frequency and Channel in "#n" were 802.11ac VHT80.



2.2 Test Mode

Final test modes are considering the modulation and worse data rates as below table.

Modulation	Data Rate
802.11a	6 Mbps
802.11n HT20	MCS0
802.11n HT40	MCS0
802.11ac VHT20	MCS0
802.11ac VHT40	MCS0
802.11ac VHT80	MCS0

Test Cases	
AC Conducted Emission	Mode 1 : WLAN (5GHZ) Link + Play News + USB Light + Speaker

Ch. #	Band IV : 5725-5850 MHz			
	802.11a	802.11n HT20	802.11n HT40	802.11ac VHT80
L Low	149	149	151	-
M Middle	157	157	-	155
H High	165	165	159	-

2.3 Connection Diagram of Test System

<WLAN Tx Mode>

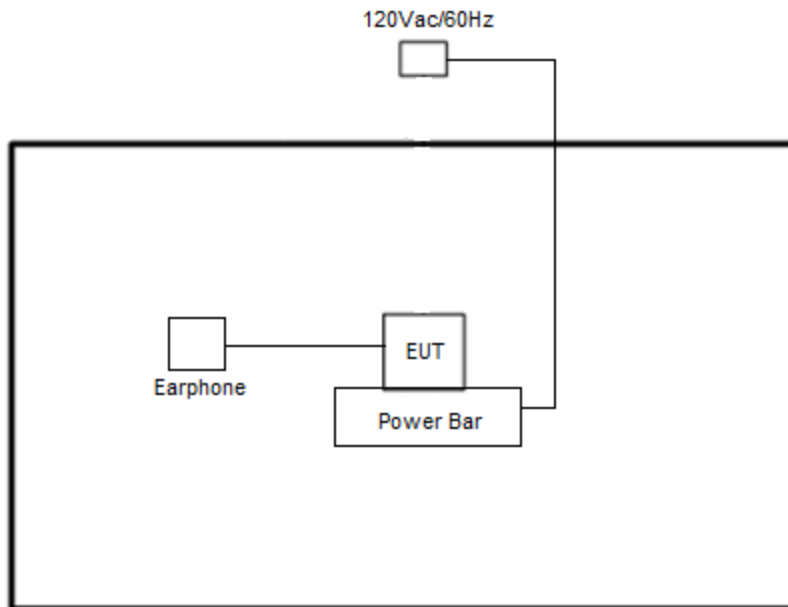

<AC Conducted Emission Mode>

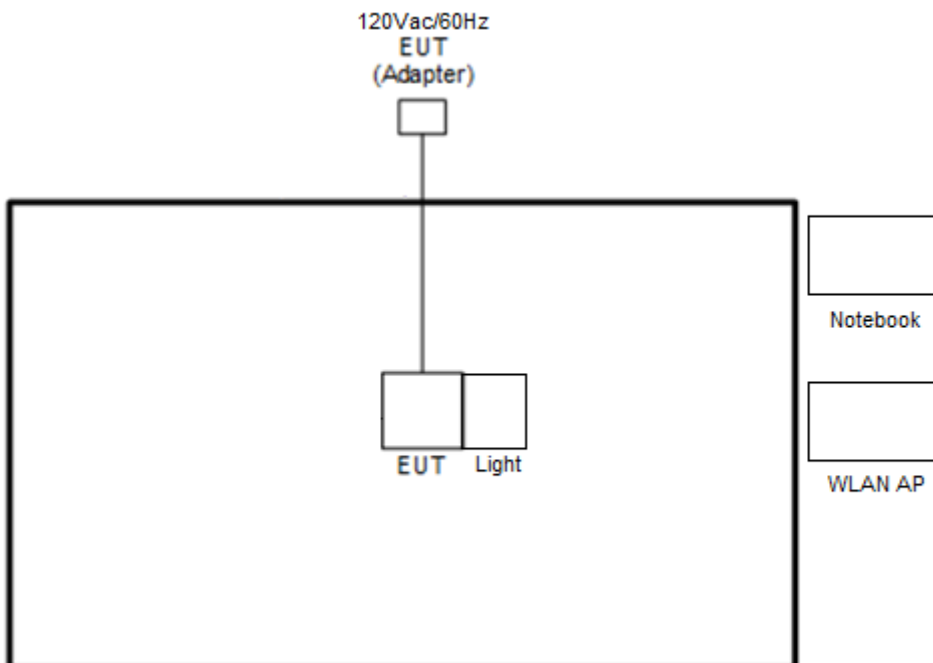

2.4 Support Unit used in test configuration and system

Item	Equipment	Trade Name	Model Name	FCC ID	Data Cable	Power Cord
1.	WLAN AP	ASUS	RT-AC1750	MSQ-RTAC66U	N/A	Unshielded, 1.8 m
2.	Notebook	DELL	Latitude E6320	FCC DoC/ Contains FCC ID: QDS-BRCM1054	N/A	AC I/P: Unshielded, 1.2 m DC O/P: Shielded, 1.8 m
3.	Speaker	JAWBONE	N/A	N/A	N/A	N/A
4.	Earphone	ipod Earphone	IP-E1	N/A	N/A	N/A

2.5 EUT Operation Test Setup

The RF test items, utility "Compliance tool 1.0.0.54" was installed in Notebook which was programmed in order to make the EUT get into the engineering modes to provide channel selection, power level, data rate and the application type and for continuous transmitting signals.

2.6 Measurement Results Explanation Example

For all conducted test items:

The offset level is set in the spectrum analyzer to compensate the RF cable loss and attenuator factor between EUT conducted output port and spectrum analyzer. With the offset compensation, the spectrum analyzer reading level is exactly the EUT RF output level.

Example :

The spectrum analyzer offset is derived from RF cable loss and attenuator factor.

Offset = RF cable loss + attenuator factor.

Following shows an offset computation example with cable loss 4.2 dB and 10dB attenuator.

$$\begin{aligned} \text{Offset(dB)} &= \text{RF cable loss(dB)} + \text{attenuator factor(dB)}. \\ &= 4.2 + 10 = 14.2 \text{ (dB)} \end{aligned}$$

3 Test Result

3.1 6dB and 26dB and 99% Occupied Bandwidth Measurement

3.1.1 Description of 6dB and 26dB and 99% Occupied Bandwidth

The minimum 6 dB bandwidth shall be at least 500 kHz.

26dB and 99% Occupied bandwidth are reporting only.

3.1.2 Measuring Instruments

See list of measuring equipment of this test report.

3.1.3 Test Procedures

1. The testing follows FCC KDB 789033 D02 General UNII Test Procedures New Rules v02r01. Section C) Emission bandwidth for the band 5.725-5.85GHz
2. Set RBW = 100kHz.
3. Set the VBW $\geq 3 \times$ RBW.
4. Detector = Peak.
5. Trace mode = max hold
6. Measure the maximum width of the emission that is 6 dB down from the peak of the emission.
7. Measure and record the results in the test report.

3.1.4 Test Setup

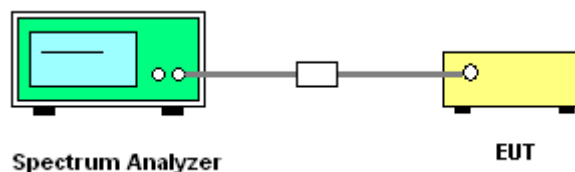

3.1.5 Test Result of 6dB and 26dB and 99% Occupied Bandwidth

Please refer to Appendix A.

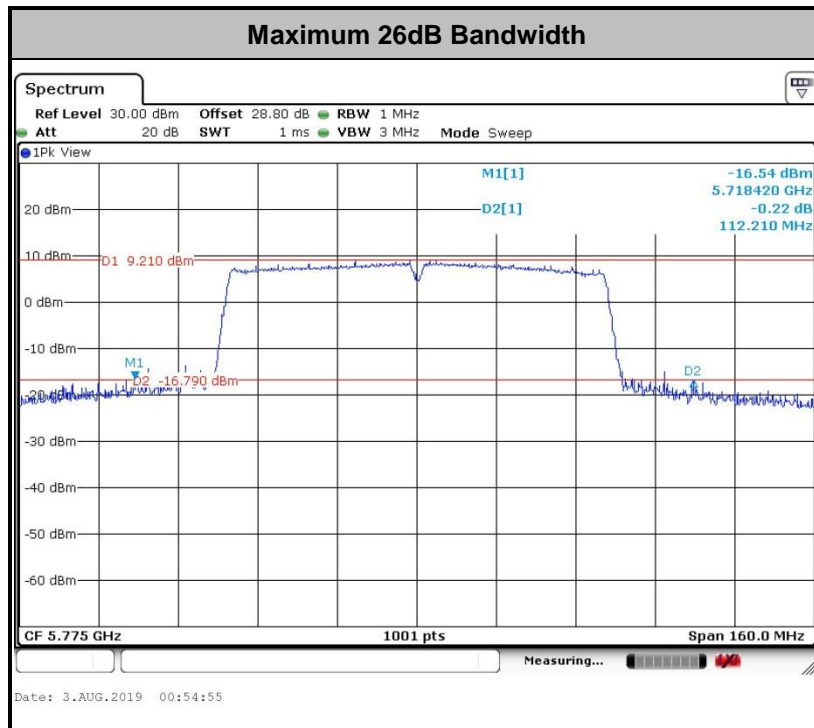
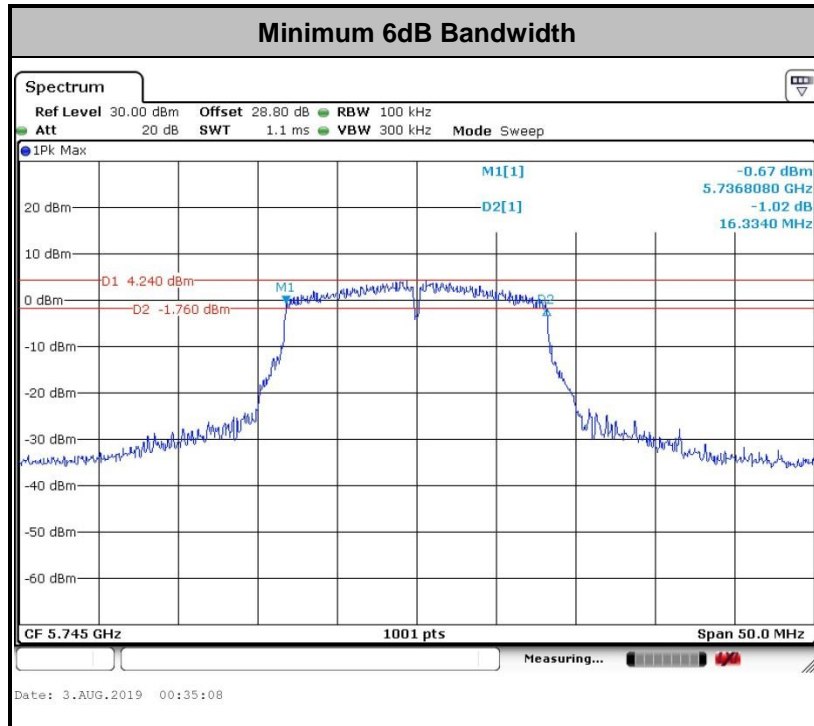

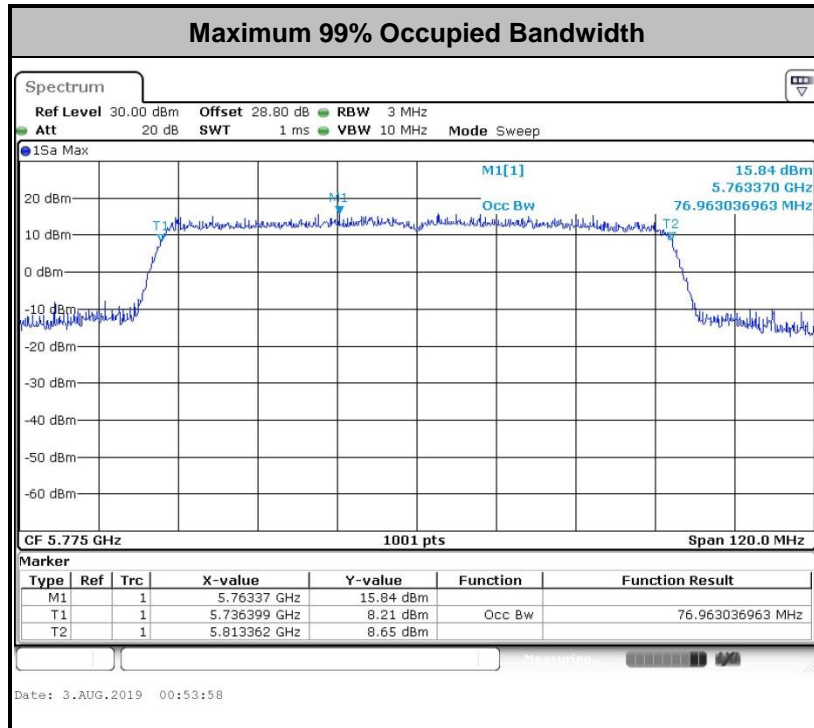

Note: The occupied channel bandwidth is maintained within the band of operation for all of the modulations.

3.2 Maximum Conducted Output Power Measurement

3.2.1 Limit of Maximum Conducted Output Power

For the band 5.725–5.85 GHz, the maximum conducted output power over the frequency band of operation shall not exceed 1 W.

If transmitting antennas of directional gain greater than 6 dBi are used, the peak output power shall be reduced by the amount in dB that the directional gain of the antenna exceeds 6 dBi.

3.2.2 Measuring Instruments

See list of measuring equipment of this test report.

3.2.3 Test Procedures

The testing follows Method PM-G of FCC KDB 789033 D02 General UNII Test Procedures New Rules v02r01.

Method PM-G (Measurement using an RF average power meter):

1. Measurement is performed using a wideband RF power meter.
2. The EUT is configured to transmit at its maximum power control level.
3. Measure the average power of the transmitter
4. Since the measurement is made only during the ON time of the transmitter, no duty cycle correction factor is required.

3.2.4 Test Setup

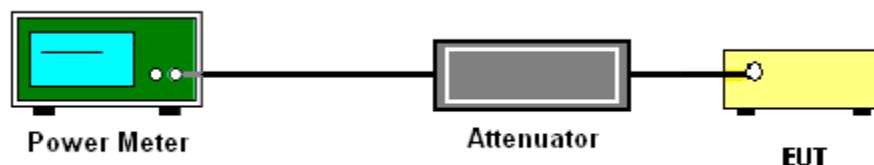

3.2.5 Test Result of Maximum Conducted Output Power

Please refer to Appendix A.



3.3 Power Spectral Density Measurement

3.3.1 Limit of Power Spectral Density

For the band 5.725–5.85 GHz, the maximum power spectral density shall not exceed 30 dBm in any 500-kHz band.

If transmitting antennas of directional gain greater than 6 dBi are used, the peak output power shall be reduced by the amount in dB that the directional gain of the antenna exceeds 6 dBi.

3.3.2 Measuring Instruments

See list of measuring equipment of this test report.

3.3.3 Test Procedures

The testing follows FCC KDB 789033 D02 General UNII Test Procedures New Rules v02r01. Section F) Maximum power spectral density.

Method SA-3

(power averaging (rms) detection with max hold):

- Set span to encompass the entire emission bandwidth (EBW) of the signal.
- Set RBW = 1 MHz.
- Set VBW \geq 3 MHz
- Number of points in sweep \geq 2 Span / RBW.
- Sweep time \leq (number of points in sweep) \times T, when duty cycle is less than 98 percent where T is the minimum transmission duration over which the transmitter is on and is transmitting at its maximum power control level for the tested mode of operation.
- Detector = power averaging (rms).
- Trace mode = max hold.
- Allow max hold to run for at least 60 seconds, or longer as needed to allow the trace to stabilize.



3.3.4 Test Result of Power Spectral Density

Please refer to Appendix A.

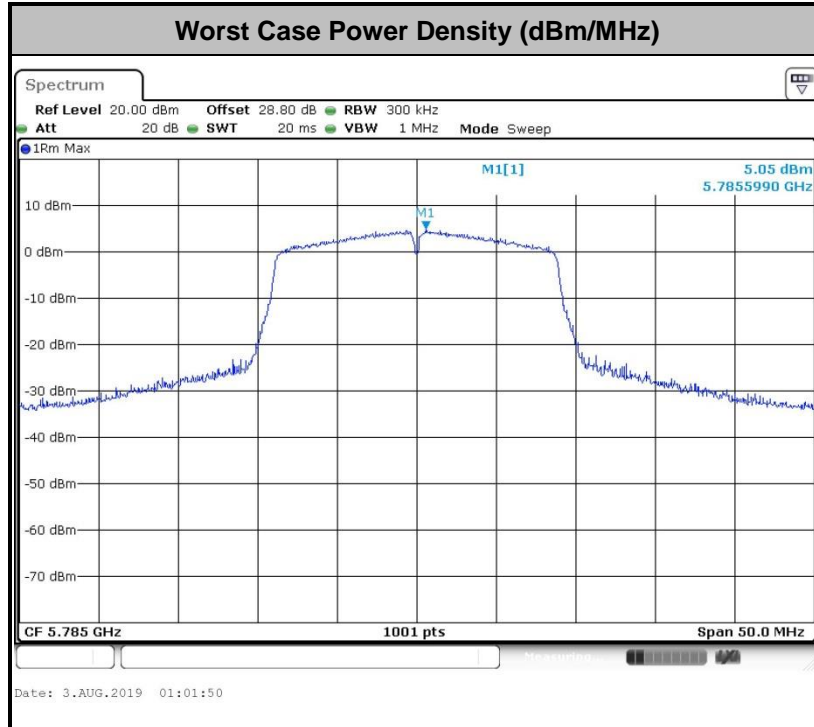



3.4 Unwanted Emissions Measurement

This section is to measure unwanted emissions through radiated measurement for band edge spurious emissions and out of band emissions measurement.

3.4.1 Limit of Unwanted Emissions

- (1) For transmitters operating in the 5.725-5.85 GHz band:
 15.407(b)(4)(i) All emissions shall be limited to a level of -27 dBm/MHz at 75 MHz or more above or below the band edge increasing linearly to 10 dBm/MHz at 25 MHz above or below the band edge, and from 25 MHz above or below the band edge increasing linearly to a level of 15.6 dBm/MHz at 5 MHz above or below the band edge, and from 5 MHz above or below the band edge increasing linearly to a level of 27 dBm/MHz at the band edge.
- (2) Unwanted spurious emissions fallen in restricted bands shall comply with the general field strength limits as below table,

Frequency (MHz)	Field Strength (microvolts/meter)	Measurement Distance (meters)
0.009 – 0.490	2400/F(kHz)	300
0.490 – 1.705	24000/F(kHz)	30
1.705 – 30.0	30	30
30 – 88	100	3
88 – 216	150	3
216 - 960	200	3
Above 960	500	3

Note: The following formula is used to convert the EIRP to field strength.

$$E = \frac{1000000\sqrt{30P}}{3} \mu\text{V/m, where P is the eirp (Watts)}$$



EIRP (dBm)	Field Strength at 3m (dBµV/m)
- 27	68.3

(3) KDB789033 D02 v02r01 G)2)c)

- (i) Section 15.407(b)(1) to (b)(3) specify the unwanted emission limits for the U-NII-1 and U-NII-2 bands. As specified, emissions above 1000 MHz that are outside of the restricted bands are subject to a peak emission limit of -27 dBm/MHz.³
- (ii) Section 15.407(b)(4) specifies the unwanted emission limit for the U-NII-3 band. A band emissions mask is specified in Section 15.407(b)(4)(i). The emission limits are in terms of a Peak detector. An alternative to the band emissions mask is specified in Section 15.407(b)(4)(ii). The alternative limits are based on the highest antenna gain specified in the filing. There are also marketing and importation restrictions for the devices using the alternative limit.⁴

Note 3: An out-of-band emission that complies with both the average and peak limits of Section 15.209 is not required to satisfy the -27 dBm/MHz peak emission limit.

Note 4: Only devices with antenna gains of 10 dBi or less may be approved using the emission limits specified in Section 15.247(d) till March 2, 2018; all other devices operating in this band must use the mask specified in Section 15.407(b)(4)(i).

3.4.2 Measuring Instruments

See list of measuring equipment of this test report.



3.4.3 Test Procedures

1. The testing follows FCC KDB 789033 D02 General UNII Test Procedures New Rules v02r01. Section G) Unwanted emissions measurement.
 - (1) Procedure for Unwanted Emissions Measurements Below 1000MHz
 - RBW = 120 kHz
 - VBW = 300 kHz
 - Detector = Peak
 - Trace mode = max hold
 - (2) Procedure for Peak Unwanted Emissions Measurements Above 1000 MHz
 - RBW = 1 MHz
 - VBW \geq 3 MHz
 - Detector = Peak
 - Sweep time = auto
 - Trace mode = max hold
 - (3) Procedures for Average Unwanted Emissions Measurements Above 1000MHz
 - RBW = 1 MHz
 - VBW = 10 Hz, when duty cycle is no less than 98 percent.
 - VBW \geq 1/T, when duty cycle is less than 98 percent where T is the minimum transmission duration over which the transmitter is on and is transmitting at its maximum power control level for the tested mode of operation.
2. The EUT was placed on a turntable with 0.8 meter for frequency below 1GHz and 1.5 meter for frequency above 1GHz respectively above ground.
3. The EUT was set 3 meters from the interference receiving antenna which was mounted on the top of a variable height antenna tower.
4. The antenna is a broadband antenna and its height is adjusted between one meter and four meters above ground to find the maximum value of the field strength for both horizontal polarization and vertical polarization of the antenna.
5. For each suspected emission, the EUT was arranged to its worst case and then adjust the antenna tower (from 1 m to 4 m) and turntable (from 0 degree to 360 degrees) to find the maximum reading.
6. For testing below 1GHz, if the emission level of the EUT in peak mode was 3 dB lower than the limit specified, then peak values of EUT will be reported, otherwise, the emissions will be repeated one by one using the CISPR quasi-peak method and reported.
7. For testing above 1GHz, the emission level of the EUT in peak mode was 20dB lower than average limit (that means the emission level in average mode also complies with the limit in average mode), then peak values of EUT will be reported, otherwise, the emissions will be measured in average mode again and reported.

3.4.4 Test Setup

For radiated emissions below 30MHz

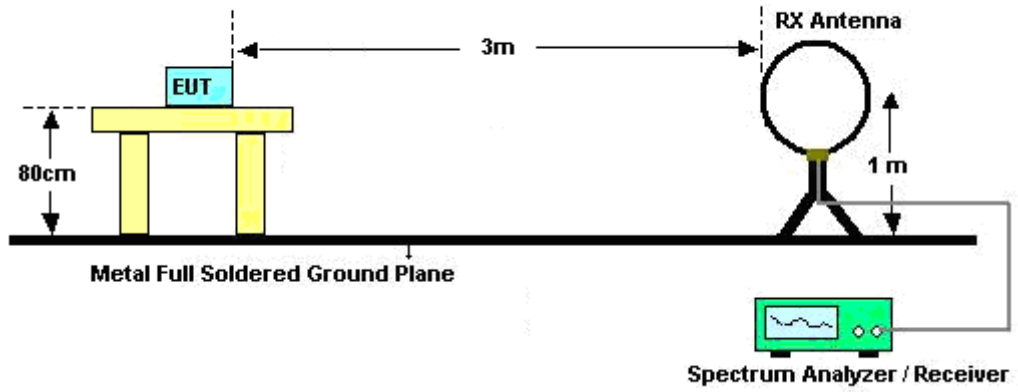

For radiated emissions from 30MHz to 1GHz

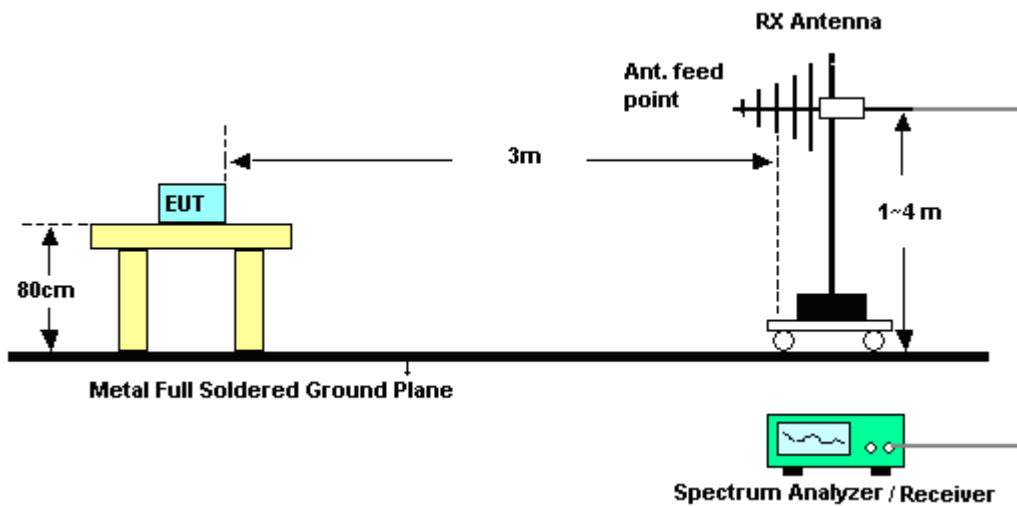

For radiated emissions above 1GHz

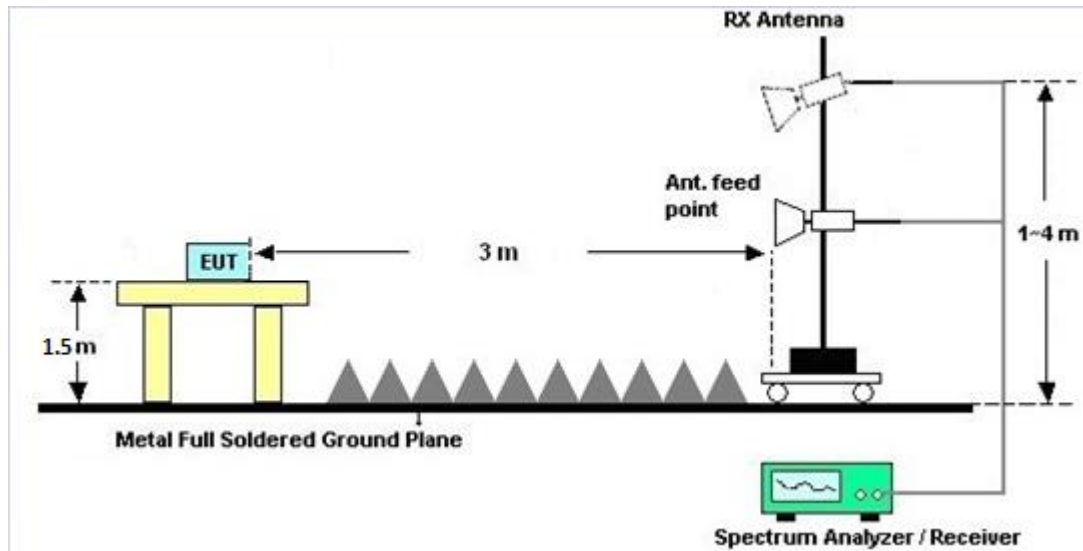

3.4.5 Test Results of Radiated Emissions (9 kHz ~ 30 MHz)

The low frequency, which started from 9 kHz to 30MHz, was pre-scanned and the result which was 20dB lower than the limit line was not reported.

There is a comparison data of both open-field test site and alternative test site - semi-Anechoic chamber according to 414788 D01 Radiated Test Site v01r01, and the result came out very similar.

3.4.6 Test Result of Radiated Band Edges

Please refer to Appendix C and D.

3.4.7 Duty Cycle

Please refer to Appendix E.

3.4.8 Test Result of Unwanted Radiated Emission (30MHz ~ 10th Harmonic)

Please refer to Appendix C and D.



3.5 AC Conducted Emission Measurement

3.5.1 Limit of AC Conducted Emission

For equipment that is designed to be connected to the public utility (AC) power line, the radio frequency voltage that is conducted back onto the AC power line on any frequency or frequencies within the band 150 kHz to 30 MHz shall not exceed the limits in the following table.

Frequency of emission (MHz)	Conducted limit (dB μ V)	
	Quasi-peak	Average
0.15-0.5	66 to 56*	56 to 46*
0.5-5	56	46
5-30	60	50

*Decreases with the logarithm of the frequency.

3.5.2 Measuring Instruments

See list of measuring equipment of this test report.

3.5.3 Test Procedures

1. The EUT was placed 0.4 meter from the conducting wall of the shielding room was kept at least 80 centimeters from any other grounded conducting surface.
2. Connect EUT to the power mains through a line impedance stabilization network (LISN).
3. All the support units are connecting to the other LISN.
4. The LISN provides 50 ohm coupling impedance for the measuring instrument.
5. The FCC states that a 50 ohm, 50 microhenry LISN should be used.
6. Both sides of AC line were checked for maximum conducted interference.
7. The frequency range from 150 kHz to 30 MHz was searched.
8. Set the test-receiver system to Peak Detect Function and specified bandwidth with Maximum Hold Mode.

3.5.4 Test Setup

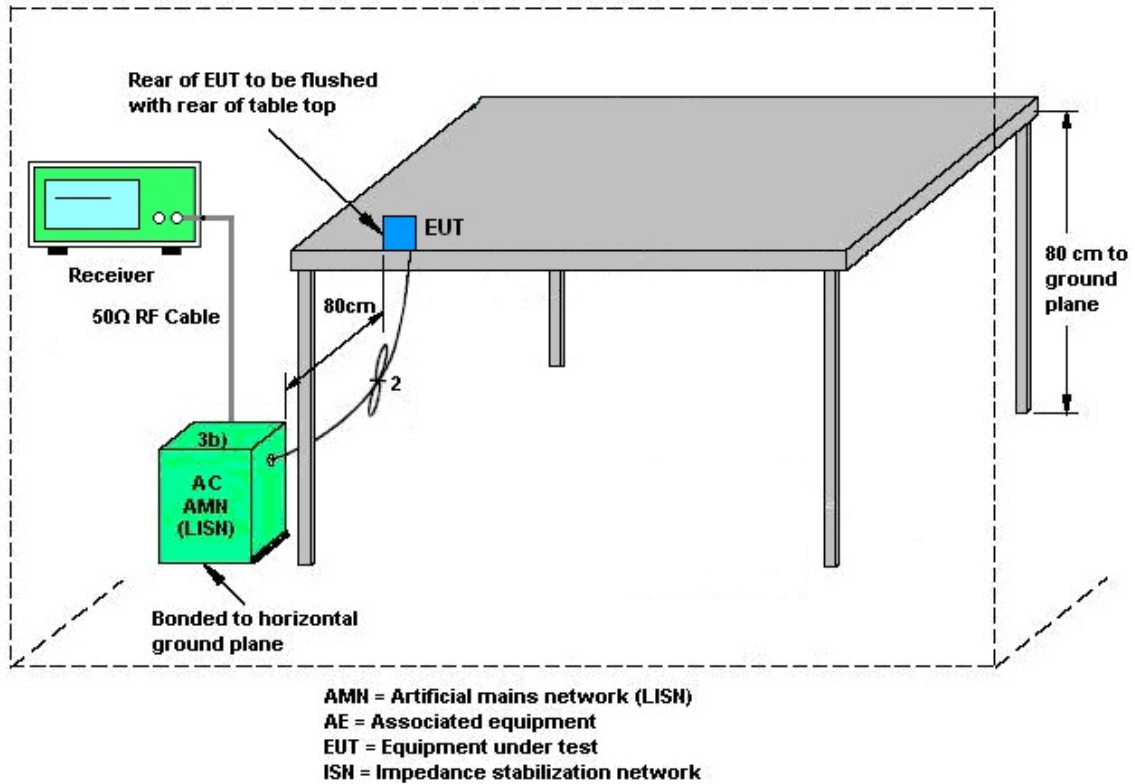

3.5.5 Test Result of AC Conducted Emission

Please refer to Appendix B.



3.6 Automatically Discontinue Transmission

3.6.1 Limit of Automatically Discontinue Transmission

The device shall automatically discontinue transmission in case of either absence of information to transmit or operational failure. These provisions are not intended to preclude the transmission of control or signaling information or the use of repetitive codes used by certain digital technologies to complete frame or burst intervals. Applicants shall include in their application for equipment authorization to describe how this requirement is met.

3.6.2 Measuring Instruments

See list of measuring equipment of this test report.

3.6.3 Test Result of Automatically Discontinue Transmission

EUT is verified this characteristic during the function check of normal sample associated with an access point:

- A. Information start: make EUT supply information to the access point.
- B. Information stop: stop supplying information to the access point.

While the EUT is not transmitting any information, the EUT can automatically discontinue transmission and become standby mode for power saving.

- C. Information start: make EUT supply information to the access point again.

The EUT can detect the controlling signal of ACK message transmitting from remote device and verify whether it shall resend or discontinue transmission.



5745MHz

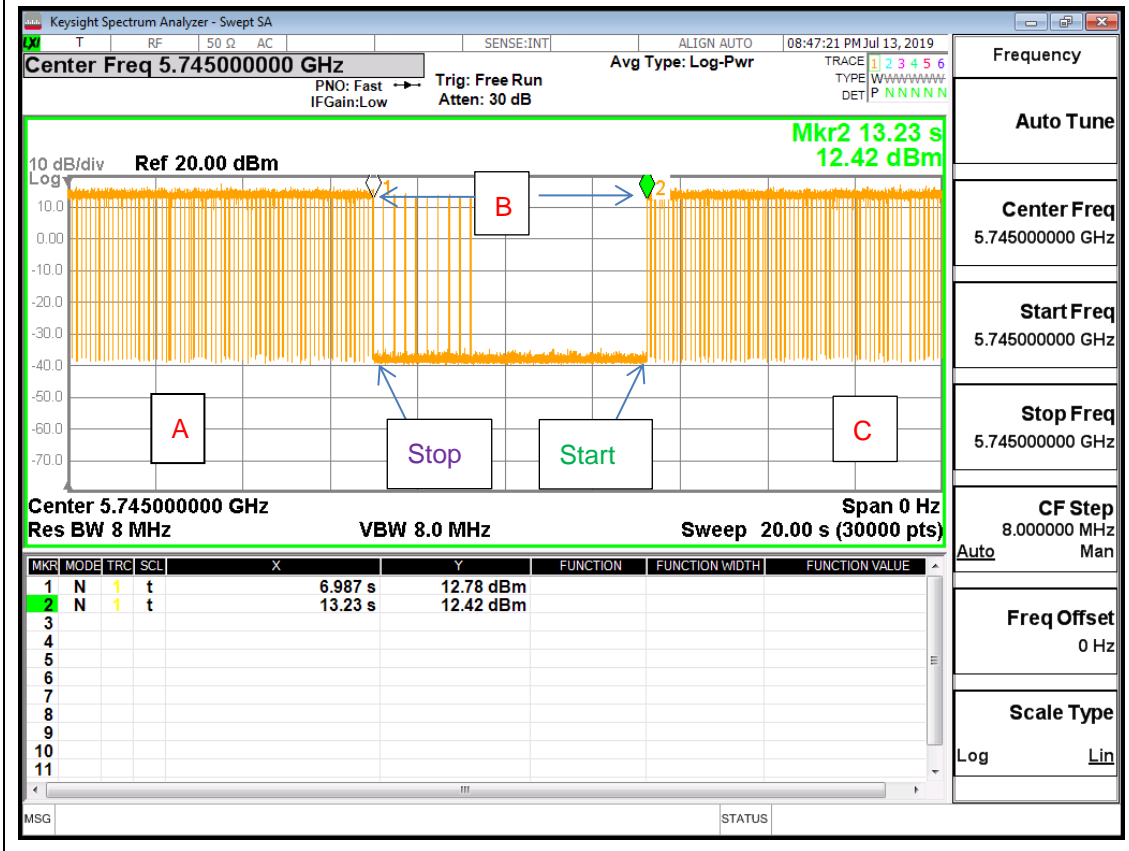

Note : The control / signalling information during the period B is precluded.



3.7 Antenna Requirements

3.7.1 Standard Applicable

If transmitting antenna directional gain is greater than 6 dBi, both the peak transmit power and the peak power spectral density shall be reduced by the amount in dB that the directional gain of the antenna exceeds 6 dBi.

3.7.2 Antenna Anti-Replacement Construction

An embedded-in antenna design is used.

3.7.3 Antenna Gain

The antenna peak gain of EUT is less than 6 dBi. Therefore, it is not necessary to reduce maximum peak output power limit.



4 List of Measuring Equipment

Instrument	Manufacturer	Model No.	Serial No.	Characteristics	Calibration Date	Test Date	Due Date	Remark
Power Sensor	DARE	RPR3006W	13I00030S NO32	9kHz~6GHz	Dec. 03, 2018	Jul. 09, 2019 ~ Aug. 06, 2019	Dec. 02, 2019	Conducted (TH05-HY)
Spectrum Analyzer	Rohde & Schwarz	FSV40	101397	10Hz~40GHz	Nov. 13, 2018	Jul. 09, 2019 ~ Aug. 06, 2019	Nov. 12, 2019	Conducted (TH05-HY)
Switch Box & RF Cable	Burgeon	ETF-058	EC120838 2	N/A	Mar. 27, 2019	Jul. 09, 2019 ~ Aug. 06, 2019	Mar. 26, 2020	Conducted (TH05-HY)
AC Power Source	ChainTek	APC-1000W	N/A	N/A	N/A	Jul. 06, 2019	N/A	Conduction (CO05-HY)
EMI Test Receiver	Rohde & Schwarz	ESR3	102388	9kHz~3.6GHz	Nov. 12, 2018	Jul. 06, 2019	Nov. 11, 2019	Conduction (CO05-HY)
LISN	Rohde & Schwarz	ENV216	100080	9kHz~30MHz	Nov. 14, 2018	Jul. 06, 2019	Nov. 13, 2019	Conduction (CO05-HY)
LISN	Rohde & Schwarz	ENV216	100081	9kHz~30MHz	Nov. 09, 2018	Jul. 06, 2019	Nov. 08, 2019	Conduction (CO05-HY)
Software	Rohde & Schwarz	EMC32 V10.30	N/A	N/A	N/A	Jul. 06, 2019	N/A	Conduction (CO05-HY)
LF Cable	HUBER + SUHNER	RG-214/U	LF01	N/A	Dec. 31, 2018	Jul. 06, 2019	Dec. 30, 2019	Conduction (CO05-HY)
Pulse Limiter	Rohde & Schwarz	ESH3-Z2	100851	N/A	Dec. 31, 2018	Jul. 06, 2019	Dec. 30, 2019	Conduction (CO05-HY)



Instrument	Manufacturer	Model No.	Serial No.	Characteristics	Calibration Date	Test Date	Due Date	Remark
Preamplifier	EMEC	EM18G40G	060715	18GHz ~ 40GHz	Dec. 06, 2018	Jul .15, 2019~ Aug .08, 2019	Dec. 05, 2019	Radiation (03CH11-HY)
Amplifier	SONOMA	310N	187312	9kHz~1GHz	Dec. 04, 2018	Jul .15, 2019~ Aug .08, 2019	Dec. 03, 2019	Radiation (03CH11-HY)
Bilog Antenna	TESEQ	CBL 6111D&N-6-0 6	35414&AT- N0602	30MHz~1GHz	Oct. 13, 2018	Jul .15, 2019~ Aug .08, 2019	Oct. 12, 2019	Radiation (03CH11-HY)
Horn Antenna	SCHWARZBE CK	BBHA 9120 D	9120D-132 6	1GHz ~ 18GHz	Oct. 30, 2018	Jul .15, 2019~ Aug .08, 2019	Oct. 29, 2019	Radiation (03CH11-HY)
Loop Antenna	Rohde & Schwarz	HFH2-Z2	100488	9 kHz~30 MHz	Nov. 22, 2018	Jul .15, 2019~ Aug .08, 2019	Nov. 21, 2019	Radiation (03CH11-HY)
Preamplifier	Keysight	83017A	MY532700 80	1GHz~26.5GHz	Nov. 14, 2018	Jul .15, 2019~ Aug .08, 2019	Nov. 13, 2020	Radiation (03CH11-HY)
Spectrum Analyzer	Keysight	N9010A	MY542004 86	10Hz ~ 44GHz	Oct. 19, 2018	Jul .15, 2019~ Aug .08, 2019	Oct. 18, 2019	Radiation (03CH11-HY)
Antenna Mast	EMEC	AM-BS-4500- B	N/A	1~4m	N/A	Jul .15, 2019~ Aug .08, 2019	N/A	Radiation (03CH11-HY)
Turn Table	EMEC	TT 2000	N/A	0~360 Degree	N/A	Jul .15, 2019~ Aug .08, 2019	N/A	Radiation (03CH11-HY)
Preamplifier	Jet-Power	JPA0118-55-3 03	171000180 0055007	1GHz~18GHz	Apr. 01, 2019	Jul .15, 2019~ Aug .08, 2019	Mar. 31, 2020	Radiation (03CH11-HY)
SHF-EHF Horn Antenna	SCHWARZBE CK	BBHA 9170	BBHA9170 584	18GHz- 40GHz	Dec. 05, 2018	Jul .15, 2019~ Aug .08, 2019	Dec. 04, 2019	Radiation (03CH11-HY)
EMI Test Receiver	Keysight	N9038A(MXE)	MY541300 85	N/A	Nov. 01, 2018	Jul .15, 2019~ Aug .08, 2019	Oct. 31, 2019	Radiation (03CH11-HY)
Software	Audix	E3 6.2009-8-24	RK-00104 2	N/A	N/A	Jul .15, 2019~ Aug .08, 2019	N/A	Radiation (03CH11-HY)
RF Cable	HUBER + SUHNER	SUCOFLEX 104	MY9837/4 PE	9kHz-30MHz	Mar. 13, 2019	Jul .15, 2019~ Aug .08, 2019	Mar. 12, 2020	Radiation (03CH11-HY)
RF Cable	HUBER + SUHNER	SUCOFLEX 102	MY2859/2	30MHz-40GHz	Mar. 13, 2019	Jul .15, 2019~ Aug .08, 2019	Mar. 12, 2020	Radiation (03CH11-HY)
RF Cable	HUBER + SUHNER	SUCOFLEX 104	MY9837/4 PE	30M-18G	Mar. 13, 2019	Jul .15, 2019~ Aug .08, 2019	Mar. 12, 2020	Radiation (03CH11-HY)
RF Cable	HUBER + SUHNER	SUCOFLEX 102	MY4274/2	30MHz-40GHz	Mar. 13, 2019	Jul .15, 2019~ Aug .08, 2019	Mar. 12, 2020	Radiation (03CH11-HY)
Filter	Wainwright	WLK4-1000-1 530-8000-40S S	SN11	1G Low Pass	Sep. 16, 2018	Jul .15, 2019~ Aug .08, 2019	Sep. 17, 2019	Radiation (03CH11-HY)
Filter	Wainwright	WHKX8-5872. 5-6750-18000 -40ST	SN3	6.75GHz High Pass	Sep. 17, 2018	Jul .15, 2019~ Aug .08, 2019	Sep. 16, 2019	Radiation (03CH11-HY)



5 Uncertainty of Evaluation

Uncertainty of Conducted Emission Measurement (150kHz ~ 30MHz)

Measuring Uncertainty for a Level of Confidence of 95% ($U = 2Uc(y)$)	2.2
---	-----

Uncertainty of Radiated Emission Measurement (30 MHz ~ 1000 MHz)

Measuring Uncertainty for a Level of Confidence of 95% ($U = 2Uc(y)$)	5.2
---	-----

Uncertainty of Radiated Emission Measurement (1000 MHz ~ 18000 MHz)

Measuring Uncertainty for a Level of Confidence of 95% ($U = 2Uc(y)$)	5.5
---	-----

Uncertainty of Radiated Emission Measurement (18000 MHz ~ 40000 MHz)

Measuring Uncertainty for a Level of Confidence of 95% ($U = 2Uc(y)$)	5.2
---	-----

Appendix A. Test Result of Conducted Test Items

Test Engineer:	Kai Liao	Temperature:	21~25	°C
Test Date:	2019/7/9 ~ 8/3	Relative Humidity:	51~54	%
TX Tool	Compliance	TX Tool Version	1.0.0.54	

TEST RESULTS DATA
6dB and 26dB EBW and 99% OBW

Band IV												
Mod.	Data Rate	NTX	CH.	Freq. (MHz)	99% Bandwidth (MHz)		26dB Bandwidth (MHz)		6 dB Bandwidth (MHz)		6 dB Bandwidth Min. Limit (MHz)	Pass/Fail
					Ant 0	Ant 1	Ant 0	Ant 1	Ant 0	Ant 1		
11a	6Mbps	1	149	5745	16.78	-	24.18	-	16.33	-	0.5	Pass
11a	6Mbps	1	157	5785	16.83	-	28.67	-	16.33	-	0.5	Pass
11a	6Mbps	1	165	5825	16.78	-	26.92	-	16.33	-	0.5	Pass
HT20	MCS0	1	149	5745	17.88	-	27.52	-	17.58	-	0.5	Pass
HT20	MCS0	1	157	5785	17.83	-	30.72	-	17.53	-	0.5	Pass
HT20	MCS0	1	165	5825	17.83	-	31.32	-	17.53	-	0.5	Pass
HT40	MCS0	1	151	5755	37.86	-	74.90	-	36.32	-	0.5	Pass
HT40	MCS0	1	159	5795	36.96	-	60.24	-	36.32	-	0.5	Pass
VHT80	MCS0	1	155	5775	76.96	-	112.21	-	76.40	-	0.5	Pass

TEST RESULTS DATA
Average Power Table

Band IV												
Mod.	Data Rate	NTX	CH.	Freq. (MHz)	Average Conducted Power (dBm)			FCC Conducted Power Limit (dBm)		DG (dBi)		Pass/Fail
					Ant 0	Ant 1	SUM	Ant 0	Ant 1	Ant 0	Ant 1	
11a	6Mbps	1	149	5745	18.30	-		30.00	-	6.00	-	Pass
11a	6Mbps	1	157	5785	18.40	-		30.00	-	6.00	-	Pass
11a	6Mbps	1	165	5825	17.30	-		30.00	-	6.00	-	Pass
HT20	MCS0	1	149	5745	18.10	-		30.00	-	6.00	-	Pass
HT20	MCS0	1	157	5785	18.10	-		30.00	-	6.00	-	Pass
HT20	MCS0	1	165	5825	17.40	-		30.00	-	6.00	-	Pass
HT40	MCS0	1	151	5755	19.90	-		30.00	-	6.00	-	Pass
HT40	MCS0	1	159	5795	19.20	-		30.00	-	6.00	-	Pass
VHT20	MCS0	1	149	5745	18.00	-		30.00	-	6.00	-	Pass
VHT20	MCS0	1	157	5785	18.00	-		30.00	-	6.00	-	Pass
VHT20	MCS0	1	165	5825	17.30	-		30.00	-	6.00	-	Pass
VHT40	MCS0	1	151	5755	19.80	-		30.00	-	6.00	-	Pass
VHT40	MCS0	1	159	5795	19.10	-		30.00	-	6.00	-	Pass
VHT80	MCS0	1	155	5775	18.00	-		30.00	-	6.00	-	Pass

TEST RESULTS DATA
Power Spectral Density

Band IV																
Mod.	Data Rate	NTX	CH.	Freq. (MHz)	Duty Factor (dB)		10log (500kHz /RBW) Factor (dB)		Average Power Density (dBm/500kHz)			Average PSD Limit (dBm/500kHz)		DG (dBi)		Pass /Fail
					Ant 0	Ant 1	Ant 0	Ant 1	Ant 0	Ant 1	SUM	Ant 0	Ant 1	Ant 0	Ant 1	
11a	6Mbps	1	149	5745	0.00	-	2.22	-	7.14	-		30.00	-	6.00	-	Pass
11a	6Mbps	1	157	5785	0.00	-	2.22	-	7.10	-		30.00	-	6.00	-	Pass
11a	6Mbps	1	165	5825	0.00	-	2.22	-	6.22	-		30.00	-	6.00	-	Pass
HT20	MCS0	1	149	5745	0.00	-	2.22	-	6.80	-		30.00	-	6.00	-	Pass
HT20	MCS0	1	157	5785	0.00	-	2.22	-	7.27	-		30.00	-	6.00	-	Pass
HT20	MCS0	1	165	5825	0.00	-	2.22	-	5.84	-		30.00	-	6.00	-	Pass
HT40	MCS0	1	151	5755	0.00	-	2.22	-	5.47	-		30.00	-	6.00	-	Pass
HT40	MCS0	1	159	5795	0.00	-	2.22	-	4.33	-		30.00	-	6.00	-	Pass
VHT80	MCS0	1	155	5775	0.00	-	2.22	-	-0.66	-		30.00	-	6.00	-	Pass



Appendix B. AC Conducted Emission Test Results

Test Engineer :	Jimmy Chang	Temperature :	24~26°C
		Relative Humidity :	52~56%

EUT Information

Report NO : 941514-01
 Test Mode : Mode 1
 Test Voltage : 120Vac/60Hz
 Phase : Line

Full Spectrum

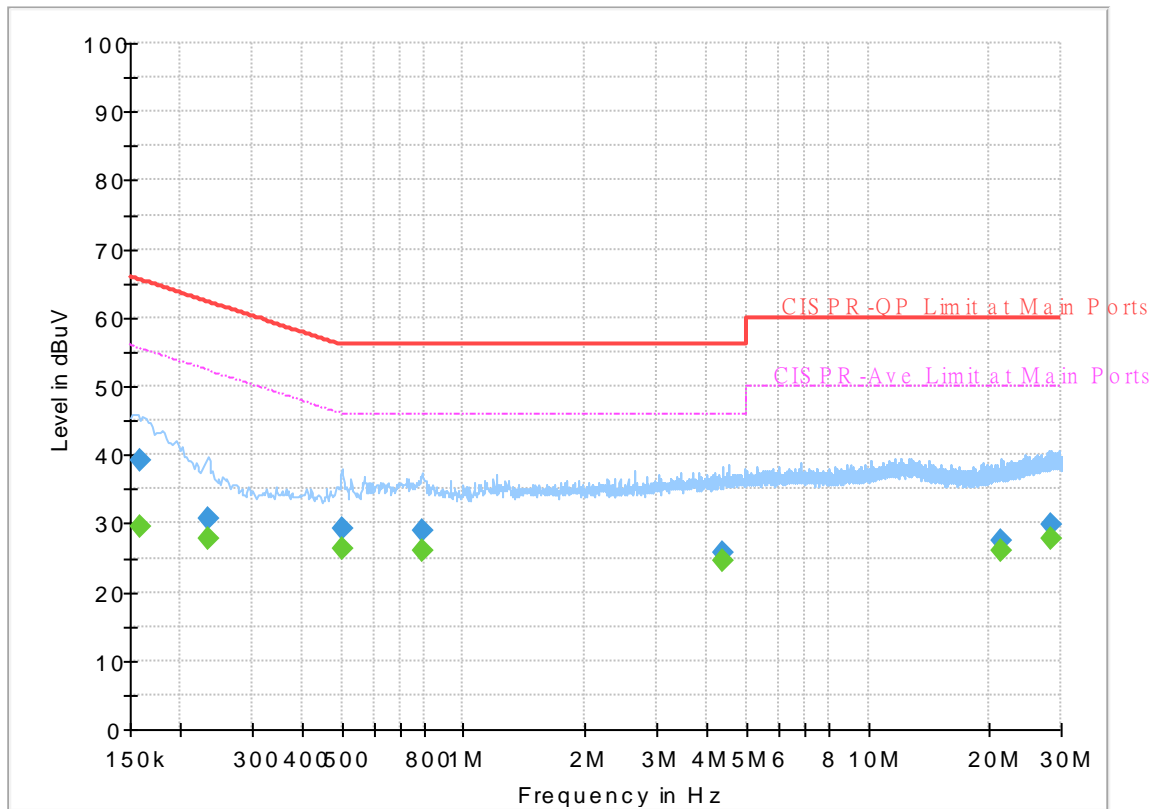

Final Result

Frequency (MHz)	QuasiPeak (dBuV)	CAverage (dBuV)	Limit (dBuV)	Margin (dB)	Line	Filter	Corr. (dB)
0.159000	---	29.42	55.52	26.10	L1	OFF	19.4
0.159000	39.13	---	65.52	26.39	L1	OFF	19.4
0.233250	---	27.76	52.33	24.57	L1	OFF	19.4
0.233250	30.60	---	62.33	31.73	L1	OFF	19.4
0.501000	---	26.46	46.00	19.54	L1	OFF	19.4
0.501000	29.22	---	56.00	26.78	L1	OFF	19.4
0.789000	---	26.15	46.00	19.85	L1	OFF	19.4
0.789000	28.83	---	56.00	27.17	L1	OFF	19.4
4.355250	---	24.48	46.00	21.52	L1	OFF	19.6
4.355250	25.65	---	56.00	30.35	L1	OFF	19.6
21.239250	---	25.97	50.00	24.03	L1	OFF	20.2
21.239250	27.61	---	60.00	32.39	L1	OFF	20.2
28.416750	---	27.88	50.00	22.12	L1	OFF	20.3
28.416750	29.79	---	60.00	30.21	L1	OFF	20.3

EUT Information

Report NO : 941514-01
 Test Mode : Mode 1
 Test Voltage : 120Vac/60Hz
 Phase : Neutral

Full Spectrum

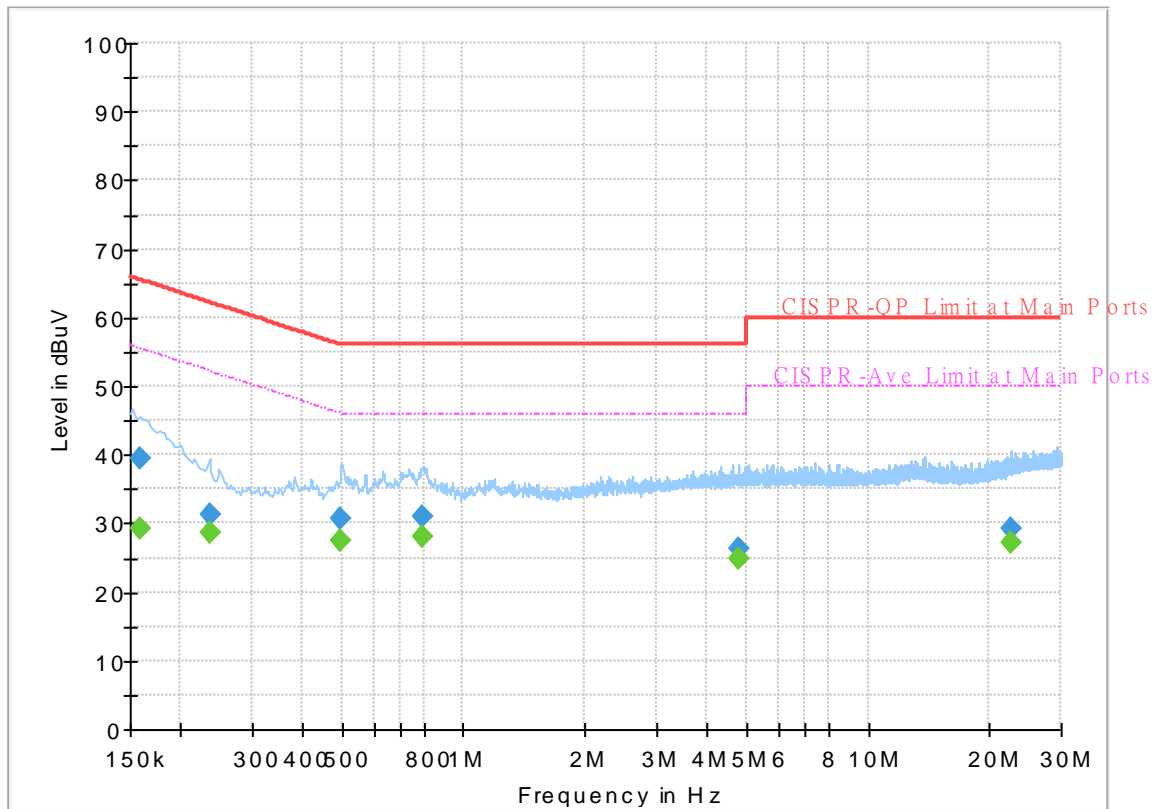

Final_Result

Frequency (MHz)	QuasiPeak (dBuV)	CAverage (dBuV)	Limit (dBuV)	Margin (dB)	Line	Filter	Corr. (dB)
0.159000	---	29.15	55.52	26.37	N	OFF	19.5
0.159000	39.38	---	65.52	26.14	N	OFF	19.5
0.235500	---	28.66	52.25	23.59	N	OFF	19.5
0.235500	31.38	---	62.25	30.87	N	OFF	19.5
0.498750	---	27.60	46.02	18.42	N	OFF	19.5
0.498750	30.58	---	56.02	25.44	N	OFF	19.5
0.795750	---	28.20	46.00	17.80	N	OFF	19.5
0.795750	31.10	---	56.00	24.90	N	OFF	19.5
4.776000	---	24.87	46.00	21.13	N	OFF	19.7
4.776000	26.25	---	56.00	29.75	N	OFF	19.7
22.656750	---	27.09	50.00	22.91	N	OFF	20.4
22.656750	29.15	---	60.00	30.85	N	OFF	20.4



Appendix C. Radiated Spurious Emission

Test Engineer :	Bill Kuo, Fu Chen and Troye Hsieh	Temperature :	22.1~28.7°C
		Relative Humidity :	50.2~56.7%

Band 4 - 5725~5850MHz

WIFI 802.11a (Band Edge @ 3m)

WIFI Ant.	Note	Frequency (MHz)	Level (dBμV/m)	Over Limit (dB)	Limit Line (dBμV/m)	Read Level (dBμV)	Antenna Factor (dB/m)	Path Loss (dB)	Preamp Factor (dB)	Ant Pos (cm)	Table Pos (deg)	Peak Avg. (P/A)	Pol. (H/V)
802.11a CH 149 5745MHz		5644.1	52.97	-15.23	68.2	43.94	31.71	10.48	33.16	224	269	P	H
		5696.75	53.32	-49.48	102.8	44	31.98	10.51	33.17	224	269	P	H
		5717.45	62.28	-47.81	110.09	52.91	32.03	10.52	33.18	224	269	P	H
		5724.2	71.85	-48.53	120.38	62.45	32.05	10.53	33.18	224	269	P	H
	*	5745	109.22	-	-	99.78	32.09	10.54	33.19	224	269	P	H
	*	5745	101.86	-	-	92.42	32.09	10.54	33.19	224	269	A	H
		5643.425	55.33	-12.87	68.2	46.3	31.71	10.48	33.16	100	274	P	V
		5696.75	56.53	-46.27	102.8	47.21	31.98	10.51	33.17	100	274	P	V
		5716.55	65.9	-43.94	109.84	56.53	32.03	10.52	33.18	100	274	P	V
		5724.425	76.23	-44.66	120.89	66.83	32.05	10.53	33.18	100	274	P	V
	*	5745	114.74	-	-	105.3	32.09	10.54	33.19	100	274	P	V
	*	5745	107.29	-	-	97.85	32.09	10.54	33.19	100	274	A	V



WIFI Ant. 0	Note	Frequency (MHz)	Level (dBμV/m)	Over Limit (dB)	Limit Line (dBμV/m)	Read Level (dBμV)	Antenna Factor (dB/m)	Path Loss (dB)	Preamp Factor (dB)	Ant Pos (cm)	Table Pos (deg)	Peak Avg. (P/A)	Pol. (H/V)
		5649.75	51.46	-16.74	68.2	42.43	31.7	10.49	33.16	100	270	P	H
		5677.75	52.5	-36.28	88.78	43.3	31.87	10.5	33.17	100	270	P	H
		5704.75	52	-54.53	106.53	42.65	32.01	10.52	33.18	100	270	P	H
		5724.25	50.51	-69.98	120.49	41.11	32.05	10.53	33.18	100	270	P	H
	*	5785	108.7	-	-	99.17	32.17	10.56	33.2	100	270	P	H
	*	5785	101.3	-	-	91.77	32.17	10.56	33.2	100	270	A	H
		5853.25	50.68	-64.11	114.79	41	32.31	10.59	33.22	100	270	P	H
		5864	51.3	-56.98	108.28	41.57	32.36	10.6	33.23	100	270	P	H
		5911.75	50.82	-27.15	77.97	40.93	32.52	10.61	33.24	100	270	P	H
		5941	50.89	-17.31	68.2	40.93	32.58	10.63	33.25	100	270	P	H
		5647.75	55.29	-12.91	68.2	46.26	31.7	10.49	33.16	100	281	P	V
		5673	55.88	-29.38	85.26	46.71	31.84	10.5	33.17	100	281	P	V
		5704.75	57.52	-49.01	106.53	48.17	32.01	10.52	33.18	100	281	P	V
		5720.25	54.89	-56.48	111.37	45.5	32.04	10.53	33.18	100	281	P	V
	*	5785	114.46	-	-	104.93	32.17	10.56	33.2	100	281	P	V
	*	5785	106.93	-	-	97.4	32.17	10.56	33.2	100	281	A	V
		5851	53.27	-66.65	119.92	43.6	32.3	10.59	33.22	100	281	P	V
		5856.5	54.31	-56.07	110.38	44.61	32.33	10.59	33.22	100	281	P	V
		5884.25	54.13	-44.2	98.33	44.32	32.44	10.6	33.23	100	281	P	V
		5932.5	52.38	-15.82	68.2	42.45	32.56	10.62	33.25	100	281	P	V



WIFI Ant. 0	Note	Frequency (MHz)	Level (dBμV/m)	Over Limit (dB)	Limit Line (dBμV/m)	Read Level (dBμV)	Antenna Factor (dB/m)	Path Loss (dB)	Preamp Factor (dB)	Ant Pos (cm)	Table Pos (deg)	Peak Avg. (P/A)	Pol. (H/V)
802.11a CH 165 5825MHz	*	5825	108.58	-	-	98.96	32.25	10.58	33.21	100	263	P	H
	*	5825	101.03	-	-	91.41	32.25	10.58	33.21	100	263	A	H
		5850.6	57.27	-63.56	120.83	47.6	32.3	10.59	33.22	100	263	P	H
		5855.2	54.46	-56.28	110.74	44.77	32.32	10.59	33.22	100	263	P	H
		5887.4	52.01	-43.98	95.99	42.19	32.45	10.6	33.23	100	263	P	H
		5944.8	50.62	-17.58	68.2	40.65	32.59	10.63	33.25	100	263	P	H
	*	5825	113.65	-	-	104.03	32.25	10.58	33.21	100	292	P	V
	*	5825	106.07	-	-	96.45	32.25	10.58	33.21	100	292	A	V
		5850.8	63.73	-56.65	120.38	54.06	32.3	10.59	33.22	100	292	P	V
		5856.2	60.26	-50.2	110.46	50.57	32.32	10.59	33.22	100	292	P	V
		5882	54.48	-45.52	100	44.68	32.43	10.6	33.23	100	292	P	V
		5927	53.44	-14.76	68.2	43.52	32.55	10.62	33.25	100	292	P	V
	Remark	<ol style="list-style-type: none"> No other spurious found. All results are PASS against Peak and Average limit line. 											



Band 4 5725~5850MHz

WIFI 802.11a (Harmonic @ 3m)

WIFI Ant. 0	Note	Frequency (MHz)	Level (dBμV/m)	Over Limit (dB)	Limit Line (dBμV/m)	Read Level (dBμV)	Antenna Factor (dB/m)	Path Loss (dB)	Preamp Factor (dB)	Ant Pos (cm)	Table Pos (deg)	Peak Avg. (P/A)	Pol. (H/V)
802.11a CH 149 5745MHz		11490	59.29	-14.71	74	64.55	39.7	17.23	62.19	200	340	P	H
		11490	47.96	-6.04	54	53.22	39.7	17.23	62.19	200	340	A	H
		17235	47.48	-20.72	68.2	43.99	40.51	22.06	59.08	100	0	P	H
		11490	58.96	-15.04	74	64.22	39.7	17.23	62.19	100	0	P	V
		11490	47.33	-6.67	54	52.59	39.7	17.23	62.19	100	0	A	V
		17235	46.94	-21.26	68.2	43.45	40.51	22.06	59.08	100	0	P	V
802.11a CH 157 5785MHz		11570	55.74	-18.26	74	61.17	39.49	17.34	62.26	100	239	P	H
		11570	45.23	-8.77	54	50.66	39.49	17.34	62.26	100	239	A	H
		17355	46.5	-21.7	68.2	42.16	40.98	22.18	58.82	100	0	P	H
		11570	57.23	-16.77	74	62.66	39.49	17.34	62.26	211	216	P	V
		11570	46.94	-7.06	54	52.37	39.49	17.34	62.26	211	216	A	V
		17355	46.47	-21.73	68.2	42.13	40.98	22.18	58.82	100	0	P	V
802.11a CH 165 5825MHz		11650	59.22	-14.78	74	64.88	39.2	17.46	62.32	279	329	P	H
		11650	47.44	-6.56	54	53.1	39.2	17.46	62.32	279	329	A	H
		17475	46.84	-21.36	68.2	41.53	41.58	22.29	58.56	100	0	P	H
		11650	59.44	-14.56	74	65.1	39.2	17.46	62.32	218	211	P	V
		11650	48.21	-5.79	54	53.87	39.2	17.46	62.32	218	211	A	V
		17475	47.45	-20.75	68.2	42.14	41.58	22.29	58.56	100	0	P	V
Remark	1. No other spurious found. 2. All results are PASS against Peak and Average limit line.												



Band 4 5725~5850MHz
WIFI 802.11n HT20 (Band Edge @ 3m)

Table with 14 columns: WIFI Ant. 0, Note, Frequency (MHz), Level (dBµV/m), Over Limit (dB), Limit Line (dBµV/m), Read Level (dBµV), Antenna Factor (dB/m), Path Loss (dB), Preamp Factor (dB), Ant Pos (cm), Table Pos (deg), Peak Avg. (P/A), Pol. (H/V). Rows include frequencies from 5633.525 to 5745 MHz with various measurement values.



WIFI Ant. 0	Note	Frequency (MHz)	Level (dBµV/m)	Over Limit (dB)	Limit Line (dBµV/m)	Read Level (dBµV)	Antenna Factor (dB/m)	Path Loss (dB)	Preamp Factor (dB)	Ant Pos (cm)	Table Pos (deg)	Peak Avg. (P/A)	Pol. (H/V)
		5634.75	52.14	-16.06	68.2	43.08	31.73	10.48	33.15	100	264	P	H
		5667	52.61	-28.21	80.82	43.47	31.8	10.5	33.16	100	264	P	H
		5706	52	-54.88	106.88	42.65	32.01	10.52	33.18	100	264	P	H
		5720.75	51.65	-60.86	112.51	42.26	32.04	10.53	33.18	100	264	P	H
	*	5785	108.06	-	-	98.53	32.17	10.56	33.2	100	264	P	H
	*	5785	100.59	-	-	91.06	32.17	10.56	33.2	100	264	A	H
		5851.5	52.06	-66.72	118.78	42.38	32.31	10.59	33.22	100	264	P	H
		5855.5	52.18	-58.48	110.66	42.49	32.32	10.59	33.22	100	264	P	H
		5889	52.66	-42.15	94.81	42.82	32.46	10.61	33.23	100	264	P	H
802.11n		5943.25	51.99	-16.21	68.2	42.02	32.59	10.63	33.25	100	264	P	H
HT20		5646.75	55.58	-12.62	68.2	46.54	31.71	10.49	33.16	100	282	P	V
CH 157		5662.25	55.82	-21.48	77.3	46.72	31.77	10.49	33.16	100	282	P	V
5785MHz		5713.5	56	-52.98	108.98	46.63	32.03	10.52	33.18	100	282	P	V
		5722.75	55.86	-61.21	117.07	46.46	32.05	10.53	33.18	100	282	P	V
	*	5785	115.01	-	-	105.48	32.17	10.56	33.2	100	282	P	V
	*	5785	107.05	-	-	97.52	32.17	10.56	33.2	100	282	A	V
		5854.75	54.48	-56.89	111.37	44.79	32.32	10.59	33.22	100	282	P	V
		5859.75	52.84	-56.63	109.47	43.14	32.34	10.59	33.23	100	282	P	V
		5888.5	53.84	-41.34	95.18	44.01	32.45	10.61	33.23	100	282	P	V
		5928	51.7	-16.5	68.2	41.77	32.56	10.62	33.25	100	282	P	V



WIFI Ant. 0	Note	Frequency (MHz)	Level (dBμV/m)	Over Limit (dB)	Limit Line (dBμV/m)	Read Level (dBμV)	Antenna Factor (dB/m)	Path Loss (dB)	Preamp Factor (dB)	Ant Pos (cm)	Table Pos (deg)	Peak Avg. (P/A)	Pol. (H/V)
802.11n HT20 CH 165 5825MHz	*	5825	107.82	-	-	98.2	32.25	10.58	33.21	102	270	P	H
	*	5825	100.19	-	-	90.57	32.25	10.58	33.21	102	270	A	H
		5850	62.2	-60	122.2	52.53	32.3	10.59	33.22	102	270	P	H
		5855	55.84	-54.96	110.8	46.15	32.32	10.59	33.22	102	270	P	H
		5903.8	52.02	-31.83	83.85	42.14	32.51	10.61	33.24	102	270	P	H
		5926.2	51.9	-16.3	68.2	41.98	32.55	10.62	33.25	102	270	P	H
	*	5825	114.66	-	-	105.04	32.25	10.58	33.21	100	279	P	V
	*	5825	106.32	-	-	96.7	32.25	10.58	33.21	100	279	A	V
		5850.2	62.86	-58.88	121.74	53.19	32.3	10.59	33.22	100	279	P	V
		5857.8	61.47	-48.54	110.01	51.77	32.33	10.59	33.22	100	279	P	V
		5887	54.52	-41.77	96.29	44.7	32.45	10.6	33.23	100	279	P	V
		5928.4	52.92	-15.28	68.2	42.99	32.56	10.62	33.25	100	279	P	V
Remark	1. No other spurious found. 2. All results are PASS against Peak and Average limit line.												



Band 4 5725~5850MHz
WIFI 802.11n HT20 (Harmonic @ 3m)

WIFI Ant. 0	Note	Frequency (MHz)	Level (dBμV/m)	Over Limit (dB)	Limit Line (dBμV/m)	Read Level (dBμV)	Antenna Factor (dB/m)	Path Loss (dB)	Preamp Factor (dB)	Ant Pos (cm)	Table Pos (deg)	Peak Avg. (P/A)	Pol. (H/V)
802.11n HT20 CH 149 5745MHz		11490	58.04	-15.96	74	63.3	39.7	17.23	62.19	201	2	P	H
		11490	46.75	-7.25	54	52.01	39.7	17.23	62.19	201	2	A	H
		17235	45.65	-22.55	68.2	42.16	40.51	22.06	59.08	100	0	P	H
		11490	57.87	-16.13	74	63.13	39.7	17.23	62.19	100	339	P	V
		11490	46.36	-7.64	54	51.62	39.7	17.23	62.19	100	339	A	V
		17235	46.99	-21.21	68.2	43.5	40.51	22.06	59.08	100	0	P	V
802.11n HT20 CH 157 5785MHz		11570	58.38	-15.62	74	63.81	39.49	17.34	62.26	204	3	P	H
		11570	46.93	-7.07	54	52.36	39.49	17.34	62.26	204	3	A	H
		17355	45.58	-22.62	68.2	41.24	40.98	22.18	58.82	100	0	P	H
		11570	59.34	-14.66	74	64.77	39.49	17.34	62.26	204	208	P	V
		11570	47.57	-6.43	54	53	39.49	17.34	62.26	204	208	A	V
		17355	45.63	-22.57	68.2	41.29	40.98	22.18	58.82	100	0	P	V
802.11n HT20 CH 165 5825MHz		11650	58.3	-15.7	74	63.96	39.2	17.46	62.32	200	357	P	H
		11650	47.39	-6.61	54	53.05	39.2	17.46	62.32	200	357	A	H
		17475	47.27	-20.93	68.2	41.96	41.58	22.29	58.56	100	0	P	H
		11650	59.52	-14.48	74	65.18	39.2	17.46	62.32	207	209	P	V
		11650	48.38	-5.62	54	54.04	39.2	17.46	62.32	207	209	A	V
		17475	47.53	-20.67	68.2	42.22	41.58	22.29	58.56	100	0	P	V
Remark	1. No other spurious found. 2. All results are PASS against Peak and Average limit line.												



Band 4 5725~5850MHz
WIFI 802.11n HT40 (Band Edge @ 3m)

WIFI Ant. 0	Note	Frequency (MHz)	Level (dBμV/m)	Over Limit (dB)	Limit Line (dBμV/m)	Read Level (dBμV)	Antenna Factor (dB/m)	Path Loss (dB)	Preamp Factor (dB)	Ant Pos (cm)	Table Pos (deg)	Peak Avg. (P/A)	Pol. (H/V)
		5648.5	54.12	-14.08	68.2	45.09	31.7	10.49	33.16	231	276	P	H
		5698	66.51	-37.22	103.73	57.18	31.99	10.51	33.17	231	276	P	H
		5716.25	80.28	-29.47	109.75	70.91	32.03	10.52	33.18	231	276	P	H
		5723.5	80.75	-38.03	118.78	71.35	32.05	10.53	33.18	231	276	P	H
	*	5755	108.35	-	-	98.88	32.11	10.55	33.19	231	276	P	H
	*	5755	99.6	-	-	90.13	32.11	10.55	33.19	231	276	A	H
		5853	50.05	-65.31	115.36	40.37	32.31	10.59	33.22	231	276	P	H
		5874.75	50.91	-54.36	105.27	41.14	32.4	10.6	33.23	231	276	P	H
802.11n		5919.25	51.58	-20.86	72.44	41.66	32.54	10.62	33.24	231	276	P	H
HT40		5929.25	50.19	-18.01	68.2	40.26	32.56	10.62	33.25	231	276	P	H
CH 151		5646.5	56.52	-11.68	68.2	47.48	31.71	10.49	33.16	100	282	P	V
5755MHz		5699.5	70.79	-34.04	104.83	61.45	32	10.51	33.17	100	282	P	V
		5718	84.27	-25.97	110.24	74.89	32.04	10.52	33.18	100	282	P	V
		5724.5	85.79	-35.27	121.06	76.39	32.05	10.53	33.18	100	282	P	V
	*	5755	113.13	-	-	103.66	32.11	10.55	33.19	100	282	P	V
	*	5755	104.91	-	-	95.44	32.11	10.55	33.19	100	282	A	V
		5850.5	55.15	-65.91	121.06	45.48	32.3	10.59	33.22	100	282	P	V
		5857.5	53.46	-56.64	110.1	43.76	32.33	10.59	33.22	100	282	P	V
		5883.5	53.65	-45.24	98.89	43.85	32.43	10.6	33.23	100	282	P	V
		5946	51.18	-17.02	68.2	41.21	32.59	10.63	33.25	100	282	P	V



WIFI Ant. 0	Note	Frequency (MHz)	Level (dBμV/m)	Over Limit (dB)	Limit Line (dBμV/m)	Read Level (dBμV)	Antenna Factor (dB/m)	Path Loss (dB)	Preamp Factor (dB)	Ant Pos (cm)	Table Pos (deg)	Peak Avg. (P/A)	Pol. (H/V)
		5630.75	51.99	-16.21	68.2	42.92	31.74	10.48	33.15	232	275	P	H
		5698.5	52.84	-51.25	104.09	43.51	31.99	10.51	33.17	232	275	P	H
		5718.25	54.5	-55.81	110.31	45.11	32.04	10.53	33.18	232	275	P	H
		5720.5	55.9	-56.04	111.94	46.51	32.04	10.53	33.18	232	275	P	H
	*	5795	106.61	-	-	97.05	32.19	10.57	33.2	232	275	P	H
	*	5795	98.09	-	-	88.53	32.19	10.57	33.2	232	275	A	H
		5851.75	53.33	-64.88	118.21	43.65	32.31	10.59	33.22	232	275	P	H
		5859.5	53.3	-56.24	109.54	43.6	32.34	10.59	33.23	232	275	P	H
802.11n		5914	51.06	-25.25	76.31	41.15	32.53	10.62	33.24	232	275	P	H
HT40		5934.75	50.49	-17.71	68.2	40.55	32.57	10.62	33.25	232	275	P	H
CH 159		5623	53.56	-14.64	68.2	44.49	31.75	10.47	33.15	100	284	P	V
5795MHz		5697.5	55.39	-47.97	103.36	46.06	31.99	10.51	33.17	100	284	P	V
		5715.75	59.47	-50.14	109.61	50.1	32.03	10.52	33.18	100	284	P	V
		5724.75	59.41	-62.22	121.63	50.01	32.05	10.53	33.18	100	284	P	V
	*	5795	110.91	-	-	101.35	32.19	10.57	33.2	100	284	P	V
	*	5795	103.09	-	-	93.53	32.19	10.57	33.2	100	284	A	V
		5850.75	60.1	-60.39	120.49	50.43	32.3	10.59	33.22	100	284	P	V
		5856.25	60.12	-50.33	110.45	50.42	32.33	10.59	33.22	100	284	P	V
		5876	53.85	-50.61	104.46	44.08	32.4	10.6	33.23	100	284	P	V
		5936.25	51.42	-16.78	68.2	41.48	32.57	10.62	33.25	100	284	P	V
Remark	1. No other spurious found. 2. All results are PASS against Peak and Average limit line.												



**Band 4 5725~5850MHz
WIFI 802.11n HT40 (Harmonic @ 3m)**

WIFI Ant. 0	Note	Frequency (MHz)	Level (dBμV/m)	Over Limit (dB)	Limit Line (dBμV/m)	Read Level (dBμV)	Antenna Factor (dB/m)	Path Loss (dB)	Preamp Factor (dB)	Ant Pos (cm)	Table Pos (deg)	Peak Avg. (P/A)	Pol. (H/V)
802.11n HT40		11510	49.78	-24.22	74	55.07	39.67	17.25	62.21	100	0	P	H
		17265	47.35	-20.85	68.2	43.68	40.6	22.09	59.02	100	0	P	H
CH 151 5755MHz		11510	49.39	-24.61	74	54.68	39.67	17.25	62.21	100	0	P	V
		17265	47.18	-21.02	68.2	43.51	40.6	22.09	59.02	100	0	P	V
802.11n HT40 CH 159 5795MHz		11590	53.45	-20.55	74	58.92	39.43	17.37	62.27	100	241	P	H
		11590	43.19	-10.81	54	48.66	39.43	17.37	62.27	100	241	A	H
		17385	47.64	-20.56	68.2	43.07	41.12	22.2	58.75	100	0	P	H
		11590	55.21	-18.79	74	60.68	39.43	17.37	62.27	201	212	P	V
		11590	44.19	-9.81	54	49.66	39.43	17.37	62.27	201	212	A	V
		17385	47.43	-20.77	68.2	42.86	41.12	22.2	58.75	100	0	P	V
Remark	1. No other spurious found. 2. All results are PASS against Peak and Average limit line.												



Band 4 5725~5850MHz
WIFI 802.11ac VHT80 (Band Edge @ 3m)

WIFI Ant. 0	Note	Frequency (MHz)	Level (dBμV/m)	Over Limit (dB)	Limit Line (dBμV/m)	Read Level (dBμV)	Antenna Factor (dB/m)	Path Loss (dB)	Preamp Factor (dB)	Ant Pos (cm)	Table Pos (deg)	Peak Avg. (P/A)	Pol. (H/V)
		5645.25	59.15	-9.05	68.2	50.12	31.71	10.48	33.16	224	228	P	H
		5688	73.54	-22.81	96.35	64.27	31.93	10.51	33.17	224	228	P	H
		5717.5	76.49	-33.61	110.1	67.12	32.03	10.52	33.18	224	228	P	H
		5722.25	75.11	-40.82	115.93	65.72	32.04	10.53	33.18	224	228	P	H
	*	5775	103.88	-	-	94.37	32.15	10.56	33.2	224	228	P	H
	*	5775	95.81	-	-	86.3	32.15	10.56	33.2	224	228	A	H
		5852	69.99	-47.65	117.64	60.31	32.31	10.59	33.22	224	228	P	H
		5858.75	67.65	-42.1	109.75	57.95	32.33	10.59	33.22	224	228	P	H
802.11ac		5875.5	58.72	-46.11	104.83	48.95	32.4	10.6	33.23	224	228	P	H
VHT80		5937	51.42	-16.78	68.2	41.48	32.57	10.62	33.25	224	228	P	H
CH 155		5649.5	60.87	-7.33	68.2	51.84	31.7	10.49	33.16	100	275	P	V
5775MHz		5697	76.51	-26.48	102.99	67.19	31.98	10.51	33.17	100	275	P	V
		5713	81.91	-26.93	108.84	72.54	32.03	10.52	33.18	100	275	P	V
		5724	81.53	-38.39	119.92	72.13	32.05	10.53	33.18	100	275	P	V
	*	5775	107.79	-	-	98.28	32.15	10.56	33.2	100	275	P	V
	*	5775	99.52	-	-	90.01	32.15	10.56	33.2	100	275	A	V
		5850.75	74.56	-45.93	120.49	64.89	32.3	10.59	33.22	100	275	P	V
		5857.25	72.77	-37.4	110.17	63.07	32.33	10.59	33.22	100	275	P	V
		5875.5	63.47	-41.36	104.83	53.7	32.4	10.6	33.23	100	275	P	V
		5934	53.83	-14.37	68.2	43.89	32.57	10.62	33.25	100	275	P	V
Remark	1. No other spurious found. 2. All results are PASS against Peak and Average limit line.												



Band 4 5725~5850MHz

WIFI 802.11ac VHT80 (Harmonic @ 3m)

WIFI Ant. 0	Note	Frequency (MHz)	Level (dBμV/m)	Over Limit (dB)	Limit Line (dBμV/m)	Read Level (dBμV)	Antenna Factor (dB/m)	Path Loss (dB)	Preamp Factor (dB)	Ant Pos (cm)	Table Pos (deg)	Peak Avg. (P/A)	Pol. (H/V)
802.11ac		11550	48.32	-25.68	74	53.7	39.55	17.31	62.24	100	0	P	H
VHT80		17325	46.08	-22.12	68.2	41.98	40.83	22.15	58.88	100	0	P	H
CH 155		11550	49.12	-24.88	74	54.5	39.55	17.31	62.24	100	0	P	V
5775MHz		17325	46.25	-21.95	68.2	42.15	40.83	22.15	58.88	100	0	P	V
Remark	1. No other spurious found. 2. All results are PASS against Peak and Average limit line.												



Emission below 1GHz

5GHz WIFI 802.11n HT20 (LF @ 3m)

WIFI	Note	Frequency	Level	Over	Limit	Read	Antenna	Path	Preamp	Ant	Table	Peak	Pol.
Ant.				Limit	Line	Level	Factor	Loss	Factor	Pos	Pos	Avg.	
0		(MHz)	(dBμV/m)	(dB)	(dBμV/m)	(dBμV)	(dB/m)	(dB)	(dB)	(cm)	(deg)	(P/A)	(H/V)
5GHz 802.11n HT20 LF		178.41	35.84	-7.66	43.5	51.33	14.88	1.89	32.26	-	-	P	H
		194.9	33.29	-10.21	43.5	48.85	14.74	1.94	32.24	-	-	P	H
		271.53	39.95	-6.05	46	51.08	18.82	2.25	32.2	100	0	P	H
		934.04	32.04	-13.96	46	29.15	29.66	4.27	31.04	-	-	P	H
		939.86	32.75	-13.25	46	29.5	29.94	4.29	30.98	-	-	P	H
		952.47	33.54	-12.46	46	29.41	30.68	4.32	30.87	-	-	P	H
		178.41	29.78	-13.72	43.5	45.27	14.88	1.89	32.26	-	-	P	V
		269.59	35.05	-10.95	46	46.13	18.88	2.24	32.2	-	-	P	V
		276.38	35.4	-10.6	46	46.6	18.72	2.27	32.19	100	0	P	V
		934.04	32.96	-13.04	46	30.07	29.66	4.27	31.04	-	-	P	V
		945.68	33.3	-12.7	46	29.62	30.31	4.3	30.93	-	-	P	V
		959.26	33.98	-12.02	46	29.47	30.97	4.34	30.8	-	-	P	V
Remark	1. No other spurious found. 2. All results are PASS against limit line.												



Note symbol

*	Fundamental Frequency which can be ignored. However, the level of any unwanted emissions shall not exceed the level of the fundamental frequency.
!	Test result is over limit line.
P/A	Peak or Average
H/V	Horizontal or Vertical



A calculation example for radiated spurious emission is shown as below:

WIFI	Note	Frequency	Level	Over	Limit	Read	Antenna	Path	Preamp	Ant	Table	Peak	Pol.
Ant.				Limit	Line	Level	Factor	Loss	Factor	Pos	Pos	Avg.	
0		(MHz)	(dBμV/m)	(dB)	(dBμV/m)	(dBμV)	(dB/m)	(dB)	(dB)	(cm)	(deg)	(P/A)	(H/V)
802.11b		2390	55.45	-18.55	74	54.51	32.22	4.58	35.86	103	308	P	H
CH 01		2390	43.54	-10.46	54	42.6	32.22	4.58	35.86	103	308	A	H
2412MHz													

1. Path Loss(dB) = Cable loss(dB) + Filter loss(dB) + Attenuator loss(dB)
2. Level(dBμV/m) = Antenna Factor(dB/m) + Path Loss(dB) + Read Level(dBμV) - Preamp Factor(dB)
3. Over Limit(dB) = Level(dBμV/m) – Limit Line(dBμV/m)

For Peak Limit @ 2390MHz:

1. Level(dBμV/m)
= Antenna Factor(dB/m) + Path Loss(dB) + Read Level(dBμV) - Preamp Factor(dB)
= 32.22(dB/m) + 4.58(dB) + 54.51(dBμV) – 35.86 (dB)
= 55.45 (dBμV/m)
2. Over Limit(dB)
= Level(dBμV/m) – Limit Line(dBμV/m)
= 55.45(dBμV/m) – 74(dBμV/m)
= -18.55(dB)

For Average Limit @ 2390MHz:

1. Level(dBμV/m)
= Antenna Factor(dB/m) + Path Loss(dB) + Read Level(dBμV) - Preamp Factor(dB)
= 32.22(dB/m) + 4.58(dB) + 42.6(dBμV) – 35.86 (dB)
= 43.54 (dBμV/m)
2. Over Limit(dB) = Level(dBμV/m) – Limit Line(dBμV/m)
= 43.54(dBμV/m) – 54(dBμV/m)
= -10.46(dB)

Both peak and average measured complies with the limit line, so test result is “PASS”.



Appendix D. Radiated Spurious Emission Plots

Test Engineer :	Bill Kuo, Fu Chen and Troye Hsieh	Temperature :	22.1~28.7°C
		Relative Humidity :	50.2~56.7%

Note symbol

-L	Low channel location
-R	High channel location



Band 4 - 5725~5850MHz
WIFI 802.11a (Band Edge @ 3m)

WIFI	Band 4 5725~5850MHz Band Edge @ 3m	
ANT	802.11a CH149 5745MHz	
0	Horizontal	Fundamental
Peak	<p>Site : 03CH11-FF Condition : PEAK_BE(84)_16-24 3m HORN 91200-HF HORIZONTAL Detector : Peak Project : 941514-01</p>	<p>Site : 03CH11-FF Condition : PEAK(LINII) 3m HORN 91200-HF HORIZONTAL Detector : Peak Project : 941514-01</p>



WIFI	Band 4 5725~5850MHz Band Edge @ 3m	
ANT	802.11a CH149 5745MHz	
0	Vertical	Fundamental
Peak	<p>Site : 03CH11-HY Condition : PEAK_8E(84)_16-24 3m HORN 91200-HF VERTICAL RBW:1000.000KHz VBW:3000.000KHz SWT:Auto Detector : Peak Project : 941514-01</p>	<p>Site : 03CH11-HY Condition : PEAK(UNII) 3m HORN 91200-HF VERTICAL RBW:1000.000KHz VBW:3000.000KHz SWT:Auto Detector : Peak Project : 941514-01</p>



WIFI	Band 4 5725~5850MHz Band Edge @ 3m	
ANT	802.11a CH157 5785MHz	
0	Horizontal	Fundamental
Peak	<p>Site : 03CH11-HY Condition : PEAK_BE(B4)_16-24 3m HORN 91200-HF HORIZONTAL RBW:1000.000KHz VBW:3000.000KHz SWT:Auto Detector : Peak Project : 941514-01</p>	<p>Site : 03CH11-HY Condition : PEAK(UNII) 3m HORN 91200-HF HORIZONTAL RBW:1000.000KHz VBW:3000.000KHz SWT:Auto Detector : Peak Project : 941514-01</p>
Peak	<p>Site : 03CH11-HY Condition : PEAK_BE(B4)_16-24 3m HORN 91200-HF HORIZONTAL RBW:1000.000KHz VBW:3000.000KHz SWT:Auto Detector : Peak Project : 941514-01</p>	Left blank



WIFI	Band 4 5725~5850MHz Band Edge @ 3m	
ANT	802.11a CH157 5785MHz	
0	Vertical	Fundamental
Peak	<p>Site : 03CH11-HY Condition : PEAK_BE(84)_16-24 3m HORN 91200-HF VERTICAL RBW:1000.000KHz VBW:3000.000KHz SWT:Auto Detector : Peak Project : 941514-01</p>	<p>Site : 03CH11-HY Condition : PEAK(UNII) 3m HORN 91200-HF VERTICAL RBW:1000.000KHz VBW:3000.000KHz SWT:Auto Detector : Peak Project : 941514-01</p>
Peak	<p>Site : 03CH11-HY Condition : PEAK_BE(84)_16-24 3m HORN 91200-HF VERTICAL RBW:1000.000KHz VBW:3000.000KHz SWT:Auto Detector : Peak Project : 941514-01</p>	Left blank



WIFI	Band 4 5725~5850MHz Band Edge @ 3m	
ANT	802.11a CH165 5825MHz	
0	Horizontal	Fundamental
Peak	<p>Site : 03CH11-HY Condition : PEAK_BE(B4)_16-24 3m HORN 91200-HF HORIZONTAL RBW:1000.000KHz VBW:3000.000KHz SWT:Auto Detector : Peak Project : 941514-01</p>	<p>Site : 03CH11-HY Condition : PEAK(UNII) 3m HORN 91200-HF HORIZONTAL RBW:1000.000KHz VBW:3000.000KHz SWT:Auto Detector : Peak Project : 941514-01</p>

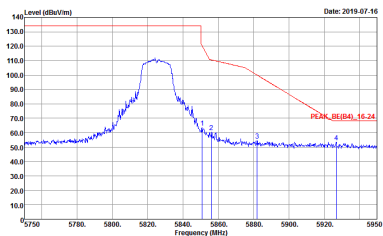
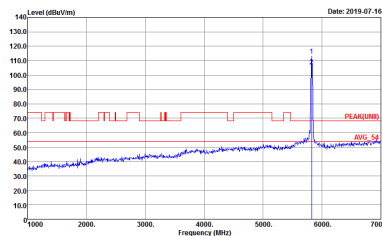

WIFI	Band 4 5725~5850MHz Band Edge @ 3m	
ANT	802.11a CH165 5825MHz	
0	Vertical	Fundamental
Peak	 <p>Date: 2019-07-16</p> <p>Site : 03CH11-HY Condition : PEAK_BE(B4)_16-24 3m HORN 9120D-HF VERTICAL RBW:1000.000KHz VBW:3000.000KHz SWT:Auto Detector : Peak Project : 941514-01</p>	 <p>Date: 2019-07-16</p> <p>Site : 03CH11-HY Condition : PEAK_UNI(B) 3m HORN 9120D-HF VERTICAL RBW:1000.000KHz VBW:3000.000KHz SWT:Auto Detector : Peak Project : 941514-01</p>



**Band 4 5725~5850MHz
WIFI 802.11n HT20 (Band Edge @ 3m)**

WIFI	Band 4 5725~5850MHz Band Edge @ 3m	
ANT	802.11n HT20 CH149 5745MHz	
0	Horizontal	Fundamental
Peak	<p>Site : 03CH11-HY Condition : PEAK_BE(B4)_16-24 3m HORN 91200-HF HORIZONTAL Detector : Peak Project : 941514-01</p>	<p>Site : 03CH11-HY Condition : PEAK(FUNB) 3m HORN 91200-HF HORIZONTAL Detector : Peak Project : 941514-01</p>



WIFI	Band 4 5725~5850MHz Band Edge @ 3m	
ANT	802.11n HT20 CH149 5745MHz	
0	Vertical	Fundamental
Peak	<p>Site : 03CH11-HY Condition : PEAK_BE(B4)_16-24 3m HORN 91200-HF VERTICAL RBW:1000.000KHz VBW:3000.000KHz SWT:Auto Detector : Peak Project : 941514-01</p>	<p>Site : 03CH11-HY Condition : PEAK(UNII) 3m HORN 91200-HF VERTICAL RBW:1000.000KHz VBW:3000.000KHz SWT:Auto Detector : Peak Project : 941514-01</p>



WIFI	Band 4 5725~5850MHz Band Edge @ 3m	
ANT	802.11n HT20 CH157 5785MHz	
0	Horizontal	Fundamental
<p>Peak</p>	<p>Site : 03CH11-HY Condition : PEAK_BE(B4)_16-24 3m HORN 9120D-HF HORIZONTAL Detector : Peak Project : 941514-01</p>	<p>Site : 03CH11-HY Condition : PEAK(UNII) 3m HORN 9120D-HF HORIZONTAL Detector : Peak Project : 941514-01</p>
<p>Peak</p>	<p>Site : 03CH11-HY Condition : PEAK_BE(B4)_16-24 3m HORN 9120D-HF HORIZONTAL Detector : Peak Project : 941514-01</p>	<p>Left blank</p>



WIFI	Band 4 5725~5850MHz Band Edge @ 3m	
ANT	802.11n HT20 CH157 5785MHz	
0	Vertical	Fundamental
Peak	<p>Site : 03CH11-HY Condition : PEAK_BE(B4)_16-24 3m HORN 91200-HF VERTICAL Detector : Peak Project : 941514-01</p>	<p>Site : 03CH11-HY Condition : PEAK(UNII) 3m HORN 91200-HF VERTICAL Detector : Peak Project : 941514-01</p>
Peak	<p>Site : 03CH11-HY Condition : PEAK_BE(B4)_16-24 3m HORN 91200-HF VERTICAL Detector : Peak Project : 941514-01</p>	Left blank

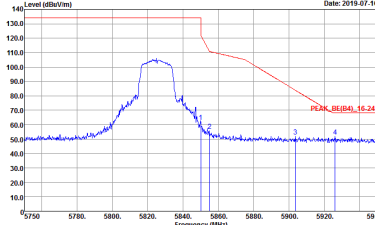
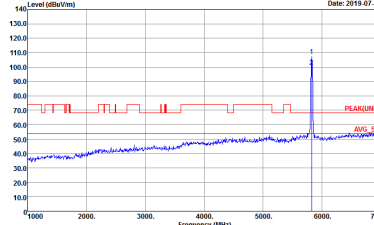

WIFI	Band 4 5725~5850MHz Band Edge @ 3m	
ANT	802.11n HT20 CH165 5825MHz	
0	Horizontal	Fundamental
Peak	 <p>Site : 03CH11-HY Condition : PEAK_BE(B4)_16-24 3m HORN 91200-HF HORIZONTAL RBW:1000.000KHz VBW:3000.000KHz SWT:Auto Detector : Peak Project : 941514-01</p>	 <p>Site : 03CH11-HY Condition : PEAK(UNII) 3m HORN 91200-HF HORIZONTAL RBW:1000.000KHz VBW:3000.000KHz SWT:Auto Detector : Peak Project : 941514-01</p>

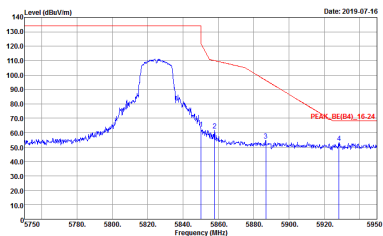
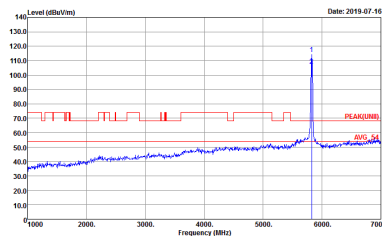

WIFI	Band 4 5725~5850MHz Band Edge @ 3m	
ANT	802.11n HT20 CH165 5825MHz	
0	Vertical	Fundamental
Peak	 <p>Date: 2019-07-16</p> <p>Site : 03CH11-HY Condition : PEAK_BE(84)_16-24 3m HORN 9120D-HF VERTICAL RBW:1000.000KHz VBW:3000.000KHz SWT:Auto Detector : Peak Project : 941514-01</p>	 <p>Date: 2019-07-16</p> <p>Site : 03CH11-HY Condition : PEAK(UNII) 3m HORN 9120D-HF VERTICAL RBW:1000.000KHz VBW:3000.000KHz SWT:Auto Detector : Peak Project : 941514-01</p>



**Band 4 5725~5850MHz
WIFI 802.11n HT40 (Band Edge @ 3m)**

WIFI	Band 4 5725~5850MHz Band Edge @ 3m	
ANT	802.11n HT40 CH151 5755MHz	
0	Horizontal	Fundamental
Peak	<p>Site : 03CH11-HY Condition : PEAK_BE(B4)_16-24 3m HORN 91200-HF HORIZONTAL RBW:1000.000KHz VBW:3000.000KHz SWT:Auto Detector : Peak Project : 941514-01</p>	<p>Site : 03CH11-HY Condition : PEAK(LMB) 3m HORN 91200-HF HORIZONTAL RBW:1000.000KHz VBW:3000.000KHz SWT:Auto Detector : Peak Project : 941514-01</p>
Peak	<p>Site : 03CH11-HY Condition : PEAK_N(B4)_16-24 3m HORN 91200-HF HORIZONTAL RBW:1000.000KHz VBW:3000.000KHz SWT:Auto Detector : Peak Project : 941514-01</p>	Left blank



WIFI	Band 4 5725~5850MHz Band Edge @ 3m	
ANT	802.11n HT40 CH151 5755MHz	
0	Vertical	Fundamental
Peak	<p>Site : 03CH11-HY Condition : PEAK_BE(B4)_16-24 3m HORN 91200-HF VERTICAL RBW:1000.000KHz VBW:3000.000KHz SWT:Auto Detector : Peak Project : 941514-01</p>	<p>Site : 03CH11-HY Condition : PEAK(UNII) 3m HORN 91200-HF VERTICAL RBW:1000.000KHz VBW:3000.000KHz SWT:Auto Detector : Peak Project : 941514-01</p>
Peak	<p>Site : 03CH11-HY Condition : PEAK_BE(B4)_16-24 3m HORN 91200-HF VERTICAL RBW:1000.000KHz VBW:3000.000KHz SWT:Auto Detector : Peak Project : 941514-01</p>	Left blank



WIFI	Band 4 5725~5850MHz Band Edge @ 3m	
ANT	802.11n HT40 CH159 5795MHz	
0	Horizontal	Fundamental
<p>Peak</p>	<p>Site : 03CH11-HY Condition : PEAK_BE(B4)_16-24 3m HORN 9120D-HF HORIZONTAL RBW:1000.000KHz VBW:3000.000KHz SWT:Auto Detector : Peak Project : 941514-01</p>	<p>Site : 03CH11-HY Condition : PEAK(UNI) 3m HORN 9120D-HF HORIZONTAL RBW:1000.000KHz VBW:3000.000KHz SWT:Auto Detector : Peak Project : 941514-01</p>
<p>Peak</p>	<p>Site : 03CH11-HY Condition : PEAK_BE(B4)_16-24 3m HORN 9120D-HF HORIZONTAL RBW:1000.000KHz VBW:3000.000KHz SWT:Auto Detector : Peak Project : 941514-01</p>	<p>Left blank</p>

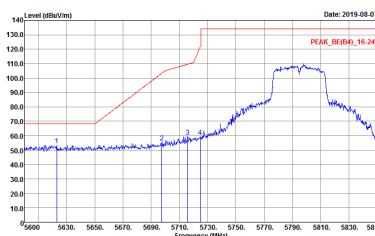
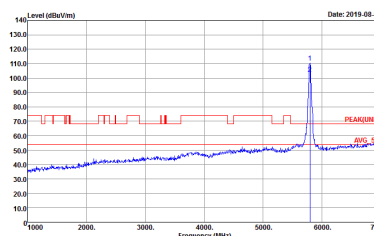
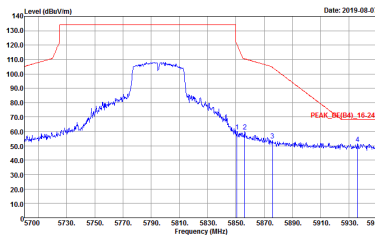

WIFI	Band 4 5725~5850MHz Band Edge @ 3m	
ANT	802.11n HT40 CH159 5795MHz	
0	Vertical	Fundamental
Peak	 <p>Date: 2019-08-07</p> <p>PEAK_BE(B4)_16-24</p> <p>Site : 03CH11-HY Condition : PEAK_BE(B4)_16-24 3m HORN 91200-HF VERTICAL RBW:1000.000KHz VBW:3000.000KHz SWT:Auto Detector : Peak Project : 941514-01</p>	 <p>Date: 2019-08-07</p> <p>PEAK(FUNB)</p> <p>Site : 03CH11-HY Condition : PEAK(FUNB)_3m HORN 91200-HF VERTICAL RBW:1000.000KHz VBW:3000.000KHz SWT:Auto Detector : Peak Project : 941514-01</p>
Peak	 <p>Date: 2019-08-07</p> <p>PEAK_BE(B4)_16-24</p> <p>Site : 03CH11-HY Condition : PEAK_BE(B4)_16-24 3m HORN 91200-HF VERTICAL RBW:1000.000KHz VBW:3000.000KHz SWT:Auto Detector : Peak Project : 941514-01</p>	Left blank



**Band 4 5725~5850MHz
WIFI 802.11ac VHT80 (Band Edge @ 3m)**

WIFI	Band 4 5725~5850MHz Band Edge @ 3m	
ANT	802.11ac VHT80 CH155 5775MHz	
0	Horizontal	Fundamental
Peak	<p>Site : 03CH11-HY Condition : PEAK_BE(B4)_16-24 3m HORN 91200-HF HORIZONTAL RBW:1000.000KHz VBW:3000.000KHz SWT:Auto Detector : Peak Project : 941514-01</p>	<p>Site : 03CH11-HY Condition : PEAK(LIN) 3m HORN 91200-HF HORIZONTAL RBW:1000.000KHz VBW:3000.000KHz SWT:Auto Detector : Peak Project : 941514-01</p>
Peak	<p>Site : 03CH11-HY Condition : PEAK_N(B4)_16-24 3m HORN 91200-HF HORIZONTAL RBW:1000.000KHz VBW:3000.000KHz SWT:Auto Detector : Peak Project : 941514-01</p>	Left blank



WIFI	Band 4 5725~5850MHz Band Edge @ 3m	
ANT	802.11ac VHT80 CH155 5775MHz	
0	Vertical	Fundamental
Peak	<p>Site : 03CH11-HY Condition : PEAK_BE(B4)_16-24 3m HORN 91200-HF VERTICAL RBW:1000.000KHz VBW:3000.000KHz SWT:Auto Detector : Peak Project : 941514-01</p>	<p>Site : 03CH11-HY Condition : PEAK(UNII) 3m HORN 91200-HF VERTICAL RBW:1000.000KHz VBW:3000.000KHz SWT:Auto Detector : Peak Project : 941514-01</p>
Peak	<p>Site : 03CH11-HY Condition : PEAK_BE(B4)_16-24 3m HORN 91200-HF VERTICAL RBW:1000.000KHz VBW:3000.000KHz SWT:Auto Detector : Peak Project : 941514-01</p>	Left blank



Band 4 - 5725~5850MHz
WIFI 802.11a (Harmonic @ 3m)

WIFI	Band 4 5725~5850MHz Harmonic @ 3m	
ANT	802.11a CH149 5745MHz	
0	Horizontal	Vertical
Peak Avg.	<p>Site : 03CH11-FY Condition : PEAK(UNII) 3m HORN 9120D-HF HORIZONTAL Detector : Peak Project : 941514-01</p>	<p>Site : 03CH11-FY Condition : PEAK(UNII) 3m HORN 9120D-HF VERTICAL Detector : Peak Project : 941514-01</p>



WIFI	Band 4 5725~5850MHz Harmonic @ 3m	
ANT	802.11a CH157 5785MHz	
0	Horizontal	Vertical
Peak Avg.	<p>Site : 03CH11-HY Condition : PEAK(UNED) 3m HORN 9120D-HF HORIZONTAL Detector : Peak Project : 941514-01</p>	<p>Site : 03CH11-HY Condition : PEAK(UNED) 3m HORN 9120D-HF VERTICAL Detector : Peak Project : 941514-01</p>



WIFI	Band 4 5725~5850MHz Harmonic @ 3m	
ANT	802.11a CH165 5825MHz	
0	Horizontal	Vertical
Peak Avg.	<p>Site : 03CH11-HY Condition : PEAK(UNED) 3m HORN 9120D-HF HORIZONTAL Detector : Peak Project : 941514-01</p>	<p>Site : 03CH11-HY Condition : PEAK(UNED) 3m HORN 9120D-HF VERTICAL Detector : Peak Project : 941514-01</p>



Band 4 5725~5850MHz
WIFI 802.11n HT20 (Harmonic @ 3m)

WIFI	Band 4 5725~5850MHz Harmonic @ 3m	
ANT	802.11n HT20 CH149 5745MHz	
0	Horizontal	Vertical
Peak Avg.	<p>Site : 03CH11-HY Condition : PEAK(UNII) 3m HORN 91200-HF HORIZONTAL Detector : Peak Project : 941514-01</p>	<p>Site : 03CH11-HY Condition : PEAK(UNII) 3m HORN 91200-HF VERTICAL Detector : Peak Project : 941514-01</p>



WIFI	Band 4 5725~5850MHz Harmonic @ 3m	
ANT	802.11n HT20 CH157 5785MHz	
0	Horizontal	Vertical
Peak Avg.	<p>Site : 03CH11-HY Condition : PEAK(UNED) 3m HORN 9120D-HF HORIZONTAL Detector : Peak Project : 941514-01</p>	<p>Site : 03CH11-HY Condition : PEAK(UNED) 3m HORN 9120D-HF VERTICAL Detector : Peak Project : 941514-01</p>



WIFI	Band 4 5725~5850MHz Harmonic @ 3m	
ANT	802.11n HT20 CH165 5825MHz	
0	Horizontal	Vertical
Peak Avg.	<p>Site : 03CH11-HY Condition : PEAK(UNED) 3m HORN 9120D-HF HORIZONTAL Detector : Peak Project : 941514-01</p>	<p>Site : 03CH11-HY Condition : PEAK(UNED) 3m HORN 9120D-HF VERTICAL Detector : Peak Project : 941514-01</p>



**Band 4 5725~5850MHz
WIFI 802.11n HT40 (Harmonic @ 3m)**

WIFI	Band 4 5725~5850MHz Harmonic @ 3m	
ANT	802.11n HT40 CH151 5755MHz	
0	Horizontal	Vertical
Peak Avg.	<p>Site : 03CH11-HY Condition : PEAK(UNII) 3m HORN 91200-HF HORIZONTAL Detector : Peak Project : 941514-01</p>	<p>Site : 03CH11-HY Condition : PEAK(UNII) 3m HORN 91200-HF VERTICAL Detector : Peak Project : 941514-01</p>



WIFI	Band 4 5725~5850MHz Harmonic @ 3m	
ANT	802.11n HT40 CH159 5795MHz	
0	Horizontal	Vertical
Peak Avg.	<p>Site : 03CH11-HY Condition : PEAK(UNED) 3m HORN 9120D-HF HORIZONTAL Detector : Peak Project : 941514-01</p>	<p>Site : 03CH11-HY Condition : PEAK(UNED) 3m HORN 9120D-HF VERTICAL Detector : Peak Project : 941514-01</p>



**Band 4 5725~5850MHz
WIFI 802.11ac VHT80 (Harmonic @ 3m)**

WIFI	Band 4 5725~5850MHz Harmonic @ 3m	
ANT	802.11ac VHT80 CH155 5775MHz	
0	Horizontal	Vertical
Peak Avg.	<p>Site : 03CH11-HY Condition : PEAK(UNII) 3m HORN 91200-HF HORIZONTAL Detector : Peak Project : 941514-01</p>	<p>Site : 03CH11-HY Condition : PEAK(UNII) 3m HORN 91200-HF VERTICAL Detector : Peak Project : 941514-01</p>



Emission below 1GHz
5GHz WIFI 802.11n HT20 (LF)

WIFI	5GHz 5725~5850MHz	
ANT	802.11n HT20 LF	
0	Horizontal	Vertical
QP / Peak	<p>Site : 03CH11-FF Condition : QP_3m BT-LOG 6111D-LF_ETC HORIZONTAL Detector : Peak Project : 941514-01</p>	<p>Site : 03CH11-FF Condition : QP_3m BT-LOG 6111D-LF_ETC VERTICAL Detector : Peak Project : 941514-01</p>



Appendix E. Duty Cycle Plots

Antenna	Band	Duty Cycle(%)	T(us)	1/T(kHz)	VBW Setting	Duty Factor(dB)
0	802.11a	100.00	-	-	10Hz	0.00
0	5GHz 802.11n HT20	100.00	-	-	10Hz	0.00
0	5GHz 802.11n HT40	100.00	-	-	10Hz	0.00
0	5GHz 802.11ac VHT20	100.00	-	-	10Hz	0.00
0	5GHz 802.11ac VHT40	100.00	-	-	10Hz	0.00
0	5GHz 802.11ac VHT80	100.00	-	-	10Hz	0.00



802.11a

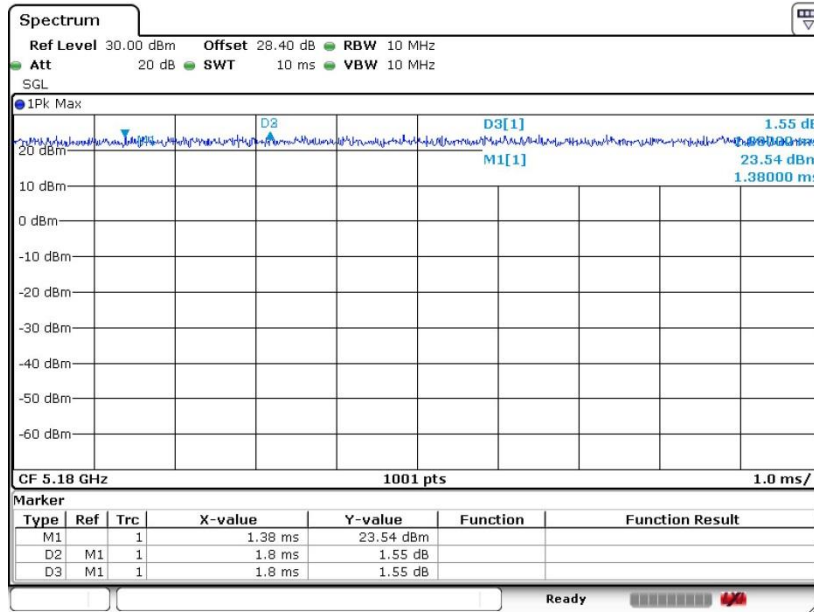

Date: 30.JUL.2019 15:57:13

802.11n HT20

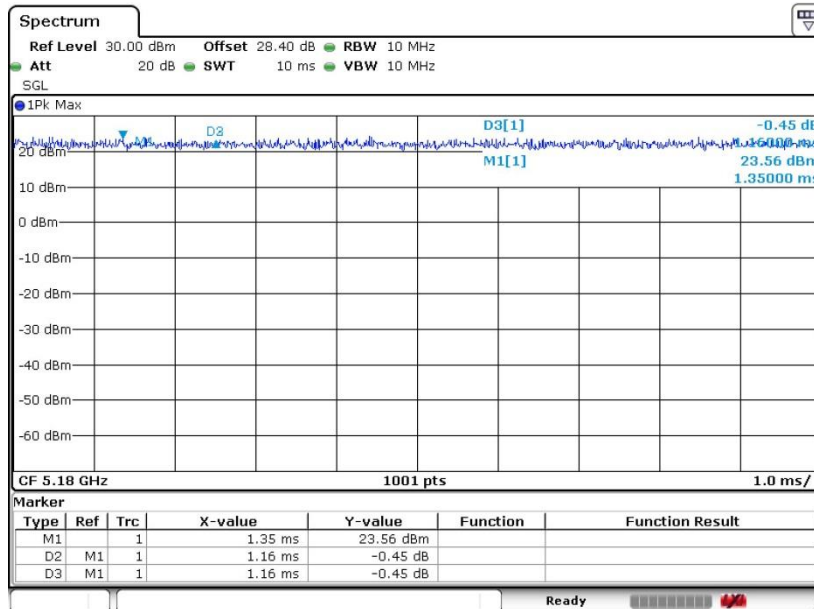

Date: 30.JUL.2019 15:55:38



802.11n HT40

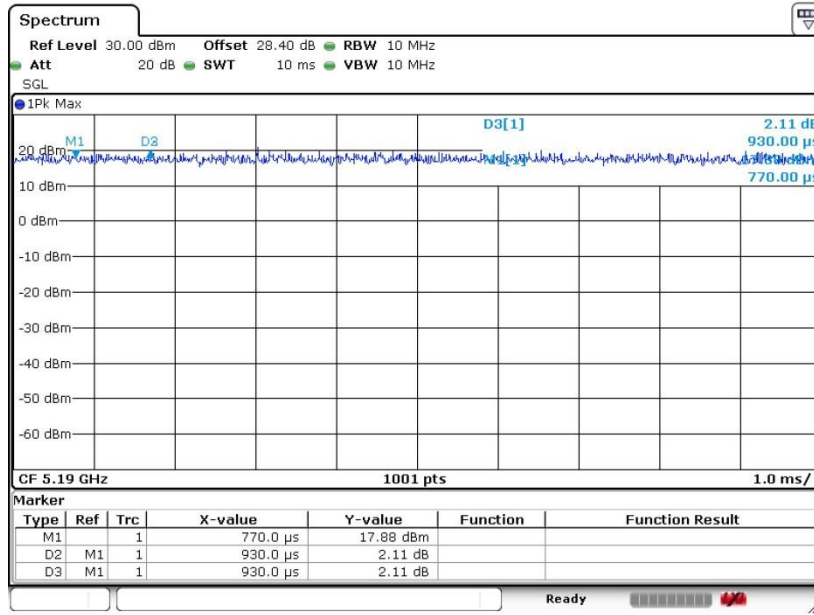

Date: 30.JUL.2019 16:02:59

802.11ac VHT20

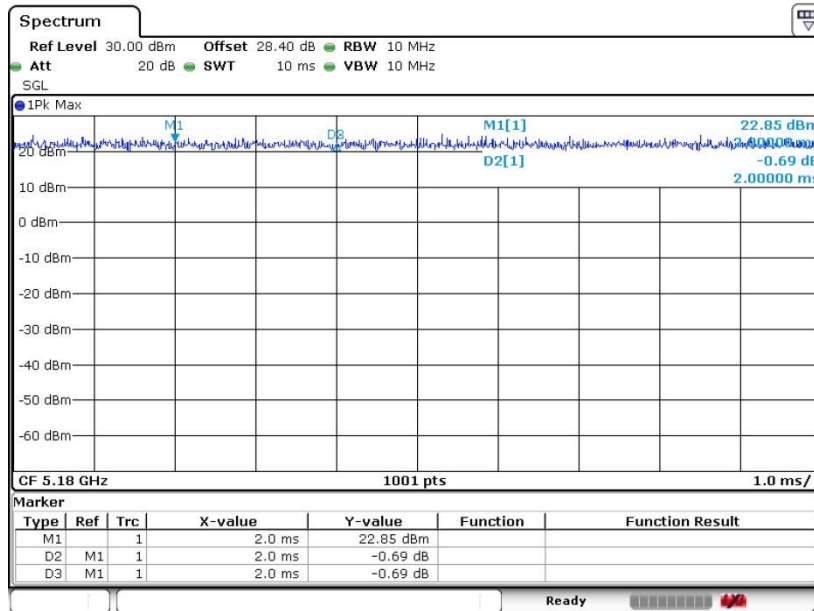

Date: 9.JUL.2019 19:47:59



802.11ac VHT40

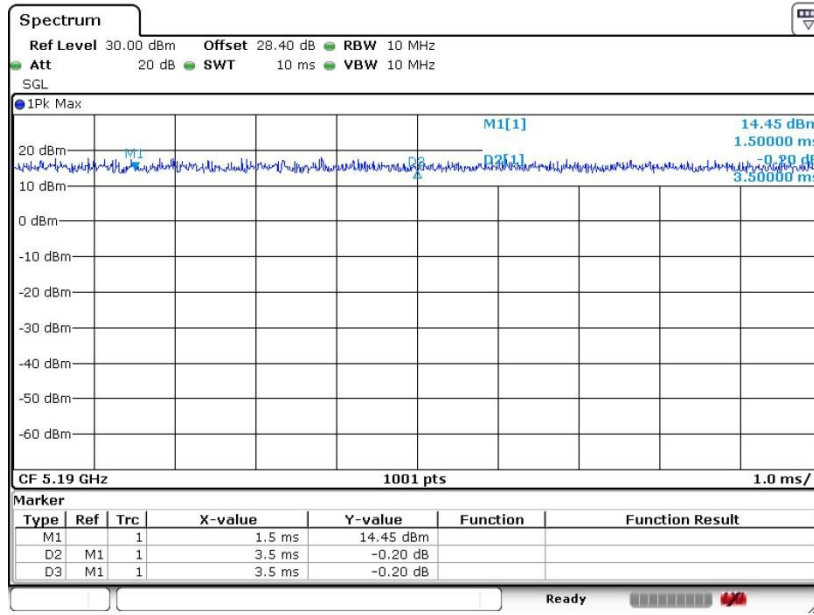

Date: 9.JUL.2019 21:03:18

802.11ac VHT80

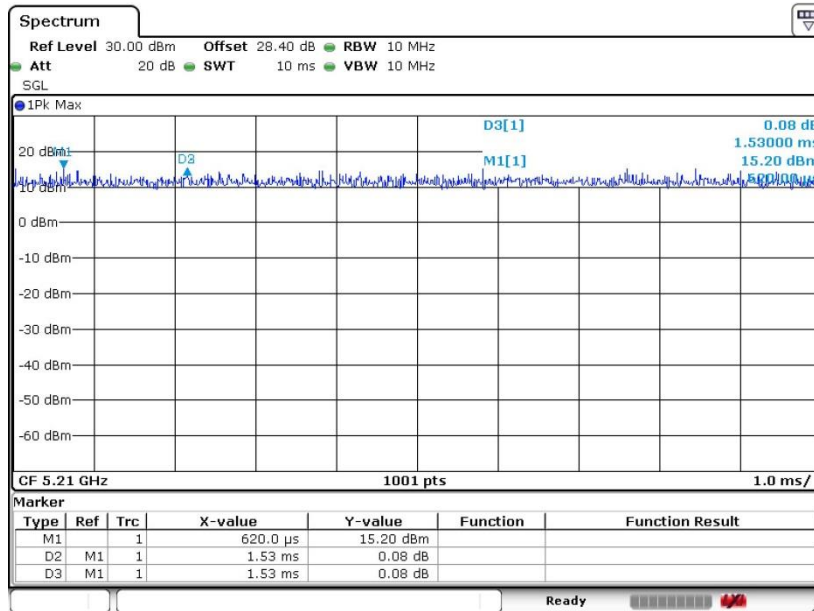

Date: 30.JUL.2019 16:01:29

————THE END————