



**DISPLAYS2GO**  
CONNECTING PEOPLE & BRANDS WITH THE WORLD

# 65" Floor Standing Digital Signage, Non-Touch

## USER MANUAL



**SKU: DF065NLB**

**FCC ID: 2ASCB-DGNEXGEN65SP**

This device complies with Part 15 of the FCC Rules. Operation is subject to the following two conditions:

- (1) this device may not cause harmful interference, and
- (2) this device must accept any interference received, including interference that may cause undesired operation.

Any changes/modifications to this equipment not approved by the party responsible for compliance could void the user's authority to operate the equipment.



---

# Thank you for purchasing this product from Displays2go.

It's our mission to help you connect with the world and build your brand with products that are personalized to your needs.

Your product has been manufactured with great care using only the finest quality materials and expert workmanship. Our Quality Assurance team inspects all electronics during assembly process to assure reliable operation. This product comes with a 12-month warranty. Scan the QR code to visit the product page and learn more about your warranty.

**Need assistance?** We are available for expert advice and all of your customer service needs.



**Chat Us**  
DISPLAYS2GO.COM



**Email Us**  
INFO@DISPLAYS2GO.COM



**Call Us**  
1-877-671-3388

# TABLE OF CONTENTS

## BEFORE USE

Safety and Warnings	4
Packing List	6
Assembly	7

## OPERATION

Remote Control	8
Interface Diagram	9
Power On/Off	9
HDMI Connection	9
Settings	10
Android 11 Quick Start Guide	10

## DIVIEX

Add Media to USB	11
DiViEX App Settings	12

## REFERENCE

Technical Specifications	14
Troubleshooting Guide	16
Cleaning and Maintenance	19
Names and Contents of Toxic and Hazardous Substances or Elements in the Product	19
FCC Compliance Notice	20



# BEFORE USE

## Safety Warnings and Precautions

Thank you for purchasing the high-performance multi-functional LED backlight Digital Signage from Displays2Go. We have considered the factors to ensure personal safety in product design and have tested rigorously at the factory. However, improper installation and use may result in electric shock and fire.

In order to safely use, maximize performance of the unit and extend the life of the product, please read and follow all instructions carefully before using the product. Keep the instructions for future reference.

We strongly recommend using a surge protector, or a power strip with internal circuit breaker to prevent damages to the digital signage.

	<b>Warning:</b> May cause personal injury or death
	The operation is prohibited
	<b>Caution:</b> May cause damage or property loss



**CAUTION / PRUDENCE**  
RISK OF ELECTRIC SHOCK DO NOT OPEN  
RISQUE DE CHOC ÉLECTRIQUE NE PAS OUVRIR



*If any of the following occurs:*

- Power outage or instable voltage.
- Abnormal sound or smell from the unit.
- AC power cord is damaged.
- Digital Signage is damaged due to drop, knock or impact.
- Any liquid or foreign matters fall into the enclosure.



Turn off the Digital Signage immediately, pull out the plug from the power outlet, and ask the authorized personnel for maintenance timely.



If coal gas or other flammable gas leaks, do not pull out the plug of the LCD digital signage or other electrical appliances; instead, turn off the gas valve immediately, and open the doors and windows quickly.

## **WARNING**

-  • Cut off the power supply before connecting or disconnecting any cables.
- Do not place the Digital Signage on any instable positions, or else it may be damaged or cause fire.
- Do not place the Digital Signage in the positions such as:
  - The environment subject to direct strong sunlight, moisture, extreme temperature or too much dust,
  - The environment with flammable or explosive materials,
  - The environment with flammable or corrosive gases,
- Do not use damaged or inappropriate power outlets, and ensure that the plugs and outlets contact properly.
- Do not let dust or metal deposits adhere to the plugs and outlets.
- Do not damage the power cords:
- Do not modify the power cords,
- Do not place heavy objects on the power cords,
  - Keep the power cords away from heat source,
  - Do not pull the cord to remove the plug.
  - Do not connect too many plugs to one outlet in parallel, or else it may cause fire due to excessive power consumption.
- Do not approach the Digital Signage with open flame (e.g. a lighted candle), or else it may cause electric shock or fire.
- Do not put any sharp objects, metal or liquid into the vents or let them touch the signal terminals to avoid short circuit, product damage, and electric shock.
- The openings in the enclosure are designed for ventilation and cooling, to ensure long time reliable running of components inside the enclosure and prevent overheating. Do not block the openings when place the unit.



Do not touch the plugs with wet fingers, or else it will cause electric shock.



Do not use the Digital Signage in stormy weather, especially when there is lightning, instead, please disconnect the power and antenna plugs to avoid lightning strike.



Do not disassemble the Digital Signage without permission, or else it may cause electric shock or fire. Please ask qualified technician for repair.



## CAUTION

- Do not let children climb onto the Digital Signage.
- Keep the small parts away from children to prevent them from swallowing.
- If the Digital Signage won't be used for a long time, please turn it off and pull out the power plug.
- To adjust the position of the Digital Signage, please disconnect all power cords and move slowly to avoid tip over.
- Do not scratch or knock the LCD with hard object, or twist and squeeze the LCD.
- Do not turn on the unit immediately when it is moved from a place with low temperature to high temperature, or else it will cause condensation and malfunction.
- Before cleaning the Digital Signage, please pull out the power plug, wipe with soft cloth, do not use industrial chemicals, prevent foreign matters from entering the machine. Improper cleaning (such as cleaning solution, water) may damage the product, erase the printed information, and even cause damage of the components if fluid flows in, resulting in machine failure.
- If the unit displays the same screen for a long time or the moving picture has fixed text or icon, it will leave ghosting on the screen and won't disappear when the unit is turned off, it is normal and isn't covered by the warranty.
- The power of the Digital Signage can be cut off by pulling out the plug.
- If the LCD screen ruptures and the liquid splashes on the skin, please rinse for 15 minutes with clean water immediately, and consult your doctor.
- To carry the Digital Signage with hands, please grab and hold the edges, do not apply pressure on the panel.
- Use the Digital Signage properly: Use in proper lighting conditions, insufficient lighting or long time watching will impair your eyesight.
- Unplug device to disconnect from power.
- Insert the plug into the outlet properly, or else it may cause sparks and fire.

The technical specifications printed herein and on the packaging are subject to change without prior notice. The Manual may be slightly different from actual operation, and the latter is applicable.

## Packing List

Name	Quantity
Digital Signage	1
Remote Control	1
Keys	2
<u>Cleaning Kit:</u> Towel and Glove	1
<u>Base screw package:</u> L-Shaped Wrench (1) Hex Screws M10*30 (12) Shim M10 (12)	1

Name	Quantity
Operation Manual	1
Power Cord	1
WIFI Antenna	1
<u>Wheel screw package:</u> Cross screwdriver (1) Cross head pad screw M6*12 (16)	1

If you have any questions regarding our products, please visit us at [www.displays2go.com](http://www.displays2go.com) or contact Displays2go customer service at 844-221-3388.

# Assembly

**!** **NOTE:** Two people required for safe assembly of product.

## UNPACKING

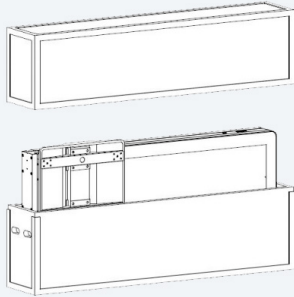

Open the top cover. Remove base from package and carefully set aside.

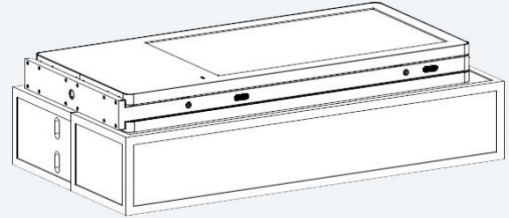

Have 2 people carefully remove unit from the package. Set it down on the shipping box to avoid scratches.

## ASSEMBLING UNIT

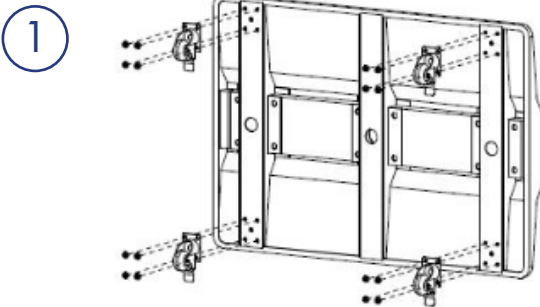

Flip base over. Insert caster posts into corresponding base slots. Screw hex screws into the 4 screw holes for each caster. Tighten all screws with cross screwdriver.

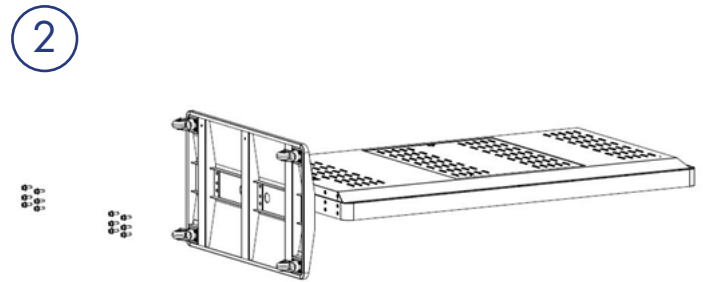

Have one person slightly tip the unit upward. Attach base to unit using hex screws. Tighten all the base screws with L-shaped hex wrench.

Have 2 people carefully lift into the standing position.

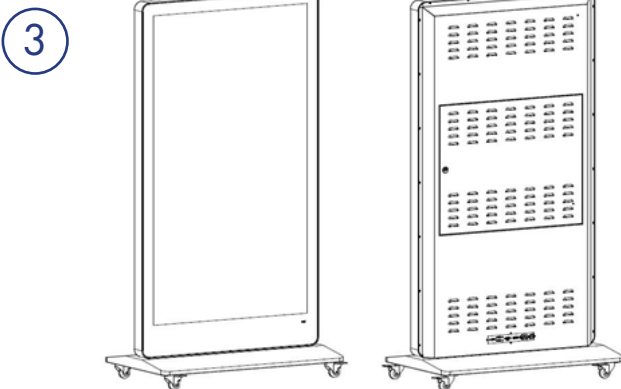

Screw antennas into antenna receivers on top of the unit.

Assembly is complete.

**!** **NOTE:** Casters can be locked for safety.

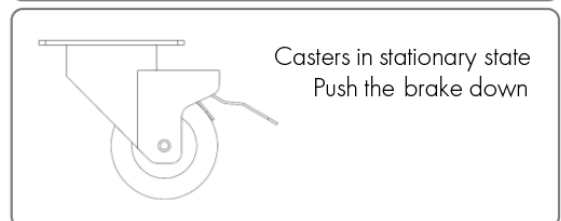
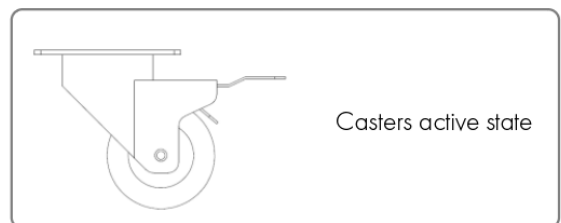

# OPERATION

## Remote Control

To control the unit, aim the remote control at the unit's receiver, located at the right corner below the screen.

For best performance, avoid exposing the receiver window to direct sunlight or placing objects between the remote control and the receiver.



## PRECAUTIONS FOR SAFE USE

- Keep the remote control away from violent vibration. In addition, do not set or place the remote control in direct sunlight, or else the remote control may be deformed by heat.
- The distance of remote control will be shortened if the battery voltage is insufficient, in this case, please replace with new batteries, if the remote control won't be used for a long time or the batteries are run out, please take out the batteries to avoid corrosion due to battery leakage, which will damage the remote control.
- Do not use batteries of different types or mix new batteries with old ones. Always replace the batteries in pairs.
- Do not put the batteries in fire, or charge or disassemble them, or charge, short circuit, disassemble, heat or burn used batteries. Please dispose of waste batteries in accordance with local environmental regulations. Do not expose the batteries in overheated environments such as sunlight and fire.



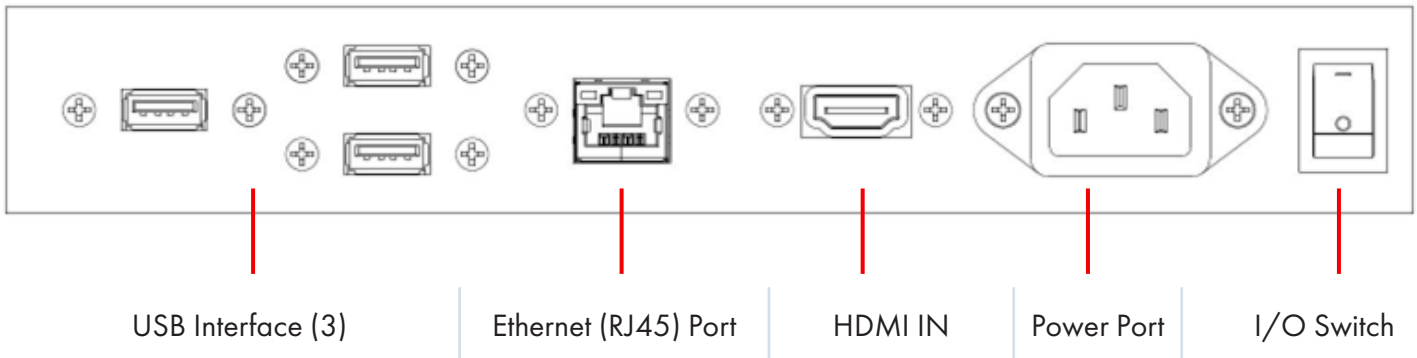

# Interface Diagram



## Power On/Off

 **CAUTION:** Disconnect the power plug before assembling or disassembling the unit!

 **NOTE:** For the safety of your product, we recommend use of a surge protector when connecting to power.

- Power on by inserting the power cord into unit and connecting to outlet.
- To turn the screen on or off, press the  power button on the remote control.
- To shut down, press the  power button on the remote control, then unplug the unit.

## HDMI Connection

1. Connect PC or media player via HDMI port.
2. Open the HDMI In app (see next page for instructions on navigating applications).  
The HDMI input appears on screen.



 **NOTE:** Some media players may not be supported.

# Settings

Once turned on, the unit automatically displays the home screen, which includes the navigation bar and the App Drawer.

**NOTE:** The Navigation bar can be minimized. To restore the navigation bar, go into Display settings and enable Display Navigation.

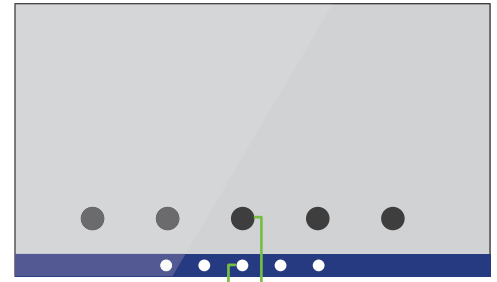

**App Drawer**  
Shows all apps

**Navigation Bar**  
Enlarged view left

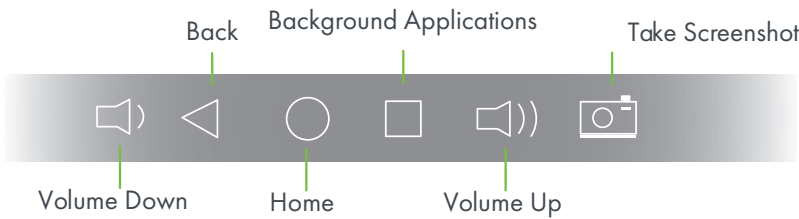

## ANDROID 11 QUICK START GUIDE

Adjust settings by tapping the App Drawer, and launching the Settings app.

### WI-FI CONNECTION



1. Open **Settings**, and select **Network and Internet** from the list of settings.
2. Select your Wi-Fi network and enter your login credentials. Click **Okay**.

**For Ethernet Connections**, plug an ethernet cable into the ethernet (RJ45) port of the unit and connect to internet router. Ethernet network connection is complete.

### BLUETOOTH



1. Open **Settings**, and select **Connected Devices**.
2. Click **Pair New Device**. Make sure your bluetooth device is in pairing mode.

For future connections, select the device from the list of previously connected Bluetooth devices.

**NOTE:** To share files over bluetooth, you must enable Wi-Fi and Bluetooth Scanning in the Location settings.

### SOUND



1. Open **Settings**, and select **Sound**.

From this menu, you can individually control the volume of alarms, calls, notifications, and your media.

You can also change default notification sounds or turn Do Not Disturb on or off.

### SYSTEM LANGUAGE



1. Open **Settings**, and select **System**.
2. Click **System Language**, then click **Languages**.
3. Click **+ Add a language** and select a language. It appears as the 2nd installed system language.
4. Drag your preferred system language to first position of the list. The system language updates automatically to the first listed language.

### SCREENSHOTS



1. Open **Settings**, and select **Screenshot**.
2. Adjust the screenshot delay and enable or disable the Screenshot button in the navigation bar.

Find recent screenshots in the **Google Files** app. Choose the unit, click **Pictures**, then click **Screenshots**.

### FACTORY RESET



1. Open **Settings**, and select **System**.
2. Select **Advanced Options**.
3. Click **Reset Options**.
4. Select **Erase All Data (Factory Reset)**. Then click **Erase All Data**.



Our DiViEX Slideshow App comes pre-installed on this digital product to provide convenience for your business content management. Easily upload your videos and images to a USB and insert into the unit. Then, open the app to launch a slideshow or adjust picture settings, add filters and stickers, queue music and more!

## ADD MEDIA TO USB

1. Insert your USB drive into your computer. Create a new folder and name it "MediaFolder".
2. In "MediaFolder," create 3 subfolders. Rename them: "Images"; "Videos"; "Music".
3. Copy your desired images, videos, and music to the corresponding folder.
4. Copy "MediaFolder" to USB and safely eject USB from computer.

› MediaFolder ›

Name

- Images
- New folder
- Videos

5. Insert USB into the unit. Open the DiViEX app.



## SUPPORTED FILE FORMATS

<b>IMAGE</b>	JPG, JPEG, BMP, PNG, GIF
<b>VIDEO</b>	AVI, MPEG4, WMV, MKV, FLV, MP4, MOV
<b>AUDIO</b>	MP3

**!** **NOTE:** If DiViEX stops running after pressing play, check:

- MediaFolder is set up correctly on the USB.
- All files in MediaFolder are the supported file formats.

# PLAYLIST SETTINGS

Edit the overall playlist settings in the **Settings** tab. Once settings are adjusted, click **PLAY** or adjust further in the Edit or Music tab.

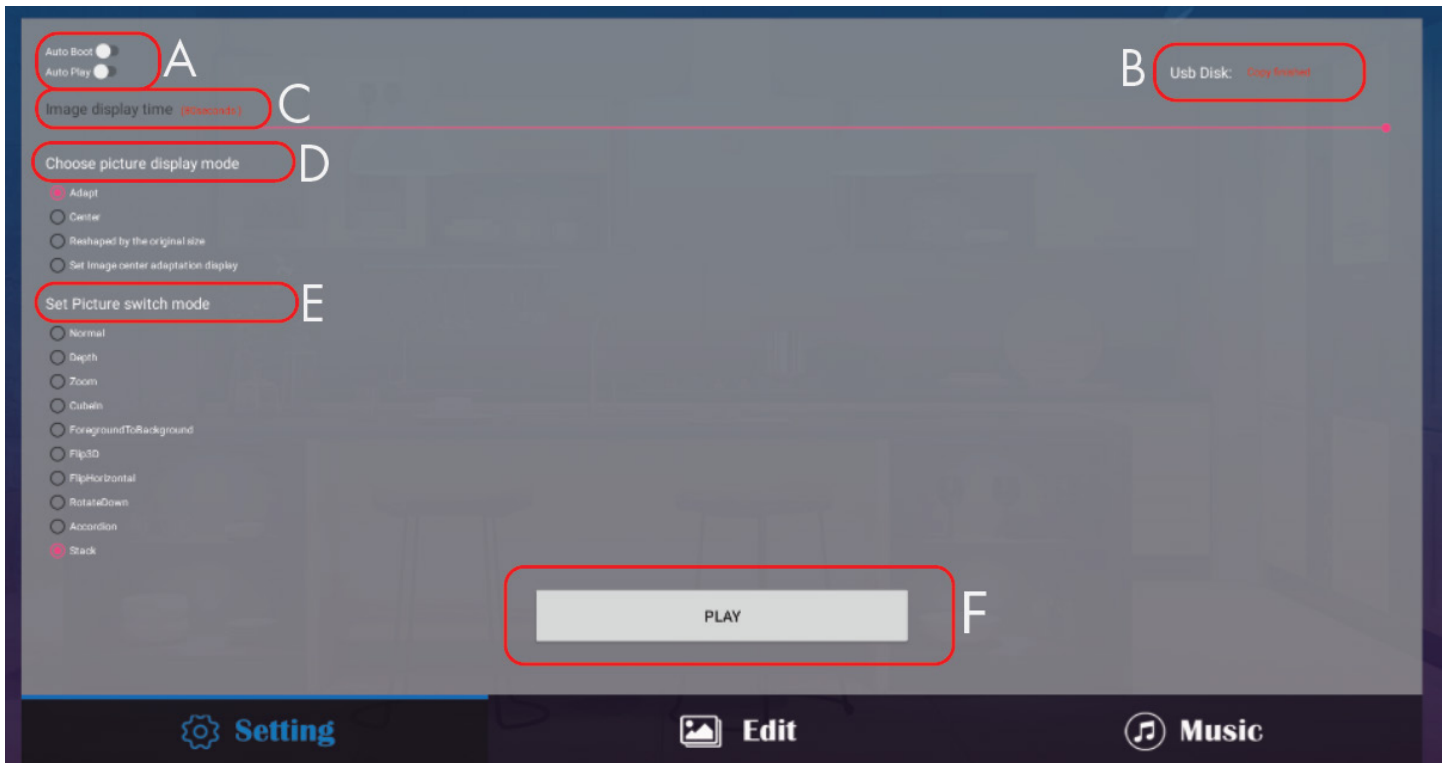

<p><b>A. AUTOMATIC SETTINGS</b></p>	<p>Enable or disable automatic settings.</p> <p><b>Auto-Boot:</b> Automatically launch DiViEX when unit is powered on</p> <p><b>Auto-Play:</b> Automatically play slideshow when DiViEX opens</p>
<p><b>B. USB DISK STATUS</b></p>	<p>Status of USB.</p>
<p><b>C. IMAGE DISPLAY TIME</b></p>	<p>How long each image is shown. Drag slider to increase or decrease.</p> <p><b>NOTE:</b> Does not apply to video</p>
<p><b>D. PICTURE DISPLAY MODE</b></p>	<p>Choose how each image/video fits on the screen.</p> <p><b>Adapt:</b> Crop image to screen</p> <p><b>Center:</b> Center image regardless of aspect ratio.</p>
<p><b>E. PICTURE SWITCH MODE</b></p>	<p>Choose animated transition effect for slideshow.</p>
<p><b>F. PLAY</b></p>	<p>Play playlist with selected settings.</p>

## EDIT

Tweak each photo individually in the Edit tab.

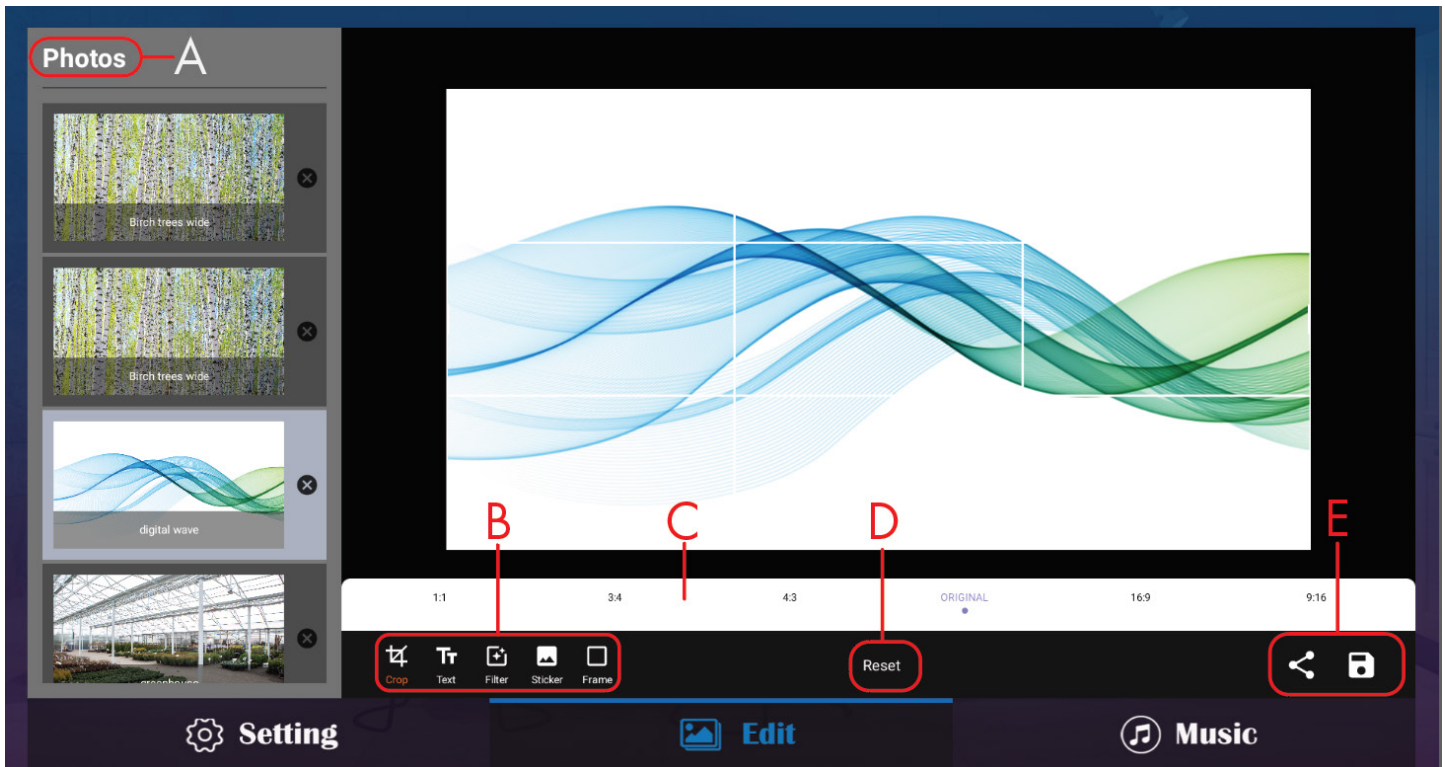

<b>A. PHOTOS</b>	Images/Video thumbnails in sequential order. Drag to rearrange.
<b>B. EDIT TOOLS</b>	Crop, Add Text, Add Filter, Add Sticker, Add Frame
<b>C. TOOLBAR</b>	This white bar shows tool options for each of the Edit tools. Choose aspect ratios when cropping, adjust text, and scroll to select stickers, frames, and filters.
<b>D. RESET</b>	Reset all edits
<b>E. SAVE / SHARE</b>	Save progress or share playlist. After saving, go back to Settings tab and press PLAY.

## MUSIC

Choose music from the Music folder to play during slideshow. Press the left arrow (F) to add music to the slideshow playlist. Press the right arrow (G) to remove songs from the playlist. The number of songs in the playlist is shown in the upper left.

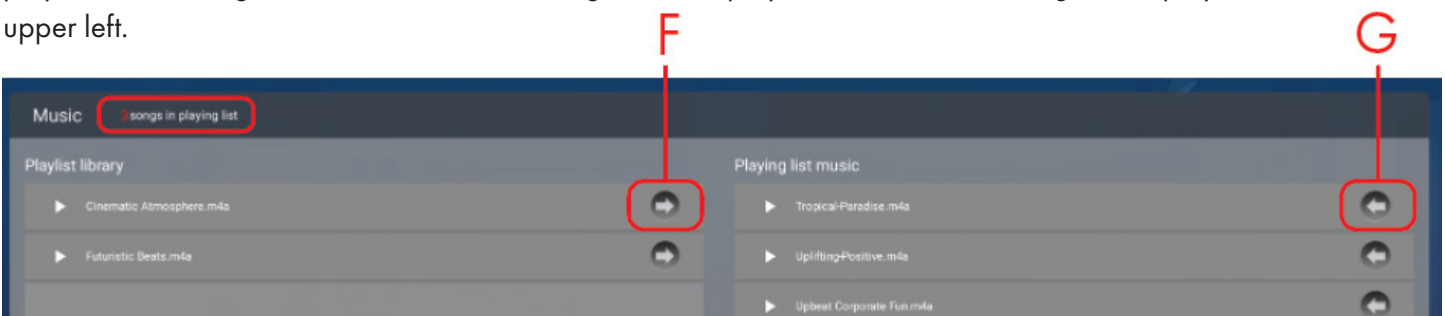

# REFERENCE

## Technical Specifications

<b>PANEL</b>	LCD Size	65"
	Light Source	LED backlight
	Resolution	3840*2160 (pixels)
	Brightness	500cd/m2
	Contrast	1200: 1
	Response	10ms
	Pixel Pitch	0.63 (H) * 0.63 (V) mm
	Refresh Rate	60Hz
	Viewing Angle	178° (H)/178° (V)
	Color Saturation	72%
	Viewable Area	1428.48 (H) * 803.52 (V) mm
	Chromaticness	1.07Billon
<b>POWER SUPPLY</b>	Voltage	100V~240V, 50-60Hz
	Power Consumption	≤310W
<b>ENVIRONMENT</b>	Operating Temperature	32°F ~ 104°F (0~40°C)
	Storage Temperature	14°F ~ 140°F (-10~60°C)
	Operating Humidity	20~80% RH Non-condensing
	Storage Humidity	10~60% RH Non-condensing
	Maximum Operating Time	18 hours /day
<b>FUNCTIONS</b>	Operating System	Android 11
	Processor	RK3568, quad-core
	RAM	4 GB
	ROM	32 GB
	Decoding Resolution	1080P UHD compatible
	Touch Support	No touch
	Supported Video Files	AVI, MPEG4, WMV, MKV, FLV, MP4, MOV
	Supported Image Files	JPG, JPEG, BMP, PNG, GIF
	Supported Audio Files	Left and right audio channel
	Audio Output	MP3
	RTC (Real-time clock)	Yes
	Schedule Power On/Off	Yes
System Update	USB Compatible	
App Installation	Support download and installation	

<b>I/O INTERFACES</b>	TF	N/A
	Ethernet (RJ45)	1
	HDMI IN	1
	VGA	N/A
	Headset	N/A
	USB	3
	Wi-Fi	1
	SIM	N/A
<b>STRUCTURE</b>	Net Weight	191.8 lbs (87kg)
	Gross Weight	231.5 lbs (105kg)
	Unit Dimensions	37.4" x 4.3" x 66.5" (950*110*1690mm)
	Package Dimensions	≈ 70" x 10.6" x 41.3" (≈ 1790*270*1050mm)
	Shell Material	Aluminum profile/sheet metal
	Shell Color	Black/White
<b>LANGUAGE</b>	OSD	English/Simplified Chinese

# Troubleshooting Guide

ISSUE	PROBABLE CAUSE	SOLUTION
<b>SCREEN IS BLACK, NO AUDIO</b>	Device is not on	Press Power button on the remote to see whether the device has been turned on. Check power connection.
	Power source or Android board is damaged.	Open the rear door to check whether the indicator light on 12/24V power supply is on. If not, replace power supply. Check whether the Android board indicator light is on. If not, replace Android board.
<b>SCREEN IS BLACK, AUDIO WORKING</b>	Constant current board malfunction	Open the access door and check wire is connected to Android board. If connection is secure, replace board.
	Android board malfunction	Open the access door and check connection. If connection is secure, replace board.
	LCD malfunction	LCD screen is dead. Replace LCD screen.
<b>SCREEN IS WHITE &amp; NO SOUND</b>	Android Board is dead	Replace Android Board.
<b>SCREEN IS WHITE BUT SOUND WORKS</b>	LVDS cable is not connected well.	Check the LVDS connection.
	Logic board is dead.	Replace logic board.
<b>SCREEN IS BLUE</b>	Issue with Android Board	Restart the device. If nothing changes, replace Android Board.
<b>SCREEN IS FLASHING</b>	Unit is placed in a magnetic environment	Change location or remove magnetic elements from environment.
	Power supply malfunction	Replace power supply.
	LVDS is affected by AC/DC power cable.	Remove LVDS cable from other cables. If it doesn't work, replace LVDS cable.
<b>SCREEN DISPLAY IS DIM</b>	LVDS Cable is dead.	Check the LVDS connection. If nothing changes, replace cord
	Android Board is dead.	Replace Android board.
<b>WHITE WIRES DISPLAYED ON SCREEN</b>	LVDS or Logic Board is dead	Replace cable or logic board.
	LCD Screen issue	If LVDS and logic board are not faulty, replace LCD screen.
<b>BACKLIGHT OFF ON HALF OF SCREEN</b>	Constant current board is dead.	Replace constant current board.
	LCD screen malfunction	Replace LCD screen.



<b>NO INTERNET – WIRE CONNECTION</b>	Ethernet not enabled in system settings.	Open <b>Settings</b> , then open <b>Network and Internet</b> . Enable ethernet.
	Ethernet cable is dead.	Replace Ethernet cable.
	Ethernet port of Android board is not working	Replace Android board.
<b>NO INTERNET – WI-FI CONNECTION</b>	Router is not working or incompatible	Check whether the Router is connected and has 2.4G. 02.11b/g/n. Try to connect device to mobile hotspot to see if the Wi-Fi function-
	Internal wi-fi connection parts damaged.	Check Wi-Fi connection cable, connection port of Android board, and the Wi-Fi antennas are working. Replace if necessary. If all are working, replace Android board.
<b>SCREEN ORIENTATION</b>	Screen orientation incorrect in Settings	Select Screen Orientation from the list of settings. Choose 180 to change the orientation from landscape to portrait.
<b>UNCLEAR DISPLAY</b>	Incorrect resolution	Reset display resolution from Settings.
<b>SPEAKER OUTPUT WEIRD OR NONE</b>	Speaker malfunction	Check speaker connection wires. Check if speakers are securely fixed on the unit. Replace speakers. If that doesn't work, replace Android board
<b>TF CARD NOT READ BY UNIT</b>	TF Card not working	Use different TF card
	TF Card Port malfunction	Try inserting card more tightly into port. If this doesn't work, the TF card port is dead. Replace Android board.
<b>UNIT TURNS OFF AFTER A PERIOD OF TIME.</b>	Settings	Check Settings to see if automatic On/Off times have been set. If not, update firmware or run factory reset.
<b>REMOTE NOT WORKING</b>	Remote is too far or has weak battery life.	Check remote indicator light to see if remote is on. Use the remote at most 10 feet away from the receiver, with no obstructions.
	Remote receiver not working.	Replace remote receiver.
<b>DEVICE DIED: NO RESPONSE OT ANY OPERATION</b>	Error	Restart device. If issue occurs again, run Factory Reset.
		Update firmware through USB port.
<b>USB NOT READ BY UNIT</b>	USB not working	Use different USB.
	USB port not working	Replace USB extension cable. Open rear door and use USB port on Android board.
<b>FIRMWARE ERROR</b>		Use a laptop to update firmware

<b>FORGOT PASSWORD</b>	Forgotten user password	Run factory reset. If password is required to do so, update firmware.
<b>HDMI INPUT NOT DISPLAYING</b>	HDMI connection delayed	Reinsert HDMI cord. If problem persists, quit media software on PC and relaunch.
	Faulty HDMI input	Try reinserting HDMI cord. If problem persists, replace HDMI input board wire.
<b>HDMI DISPLAY FROZEN</b>	HDMI connection delayed	Reinsert HDMI cord.
<b>NO SOUND FROM HDMI INPUT SOURCE</b>	HDMI connection delayed	Reinsert HDMI cord.

 **NOTE:** Do not attempt to replace or repair circuitry yourself. Contact customer service to schedule a professional maintenance appointment.

If all the potential solutions have been tested for a particular issue and problems have not been resolved, contact a customer service representative for guidance.

**844-221-3388**

**info@displays2go.com**

# Cleaning and Maintenance

- Avoid strong vibration or impact on the product.
- Keep the product dry to avoid possible damage by moisture.
- Don't place the product under direct sunlight which may shorten the service life of the screen.
- Clean screen and product by using a glass cleaner.

## Names and Contents of Toxic and Hazardous Substances or Elements in the Product

The table shows that the machine contains harmful substances inside. The data is provided by material suppliers and verified by the company according to the material type. Some materials contain harmful substances that can't be replaced in present technology. We are dedicated to improving this.

O: the content of the toxic and hazardous substances or elements in the part is lower than the limit specified in GB/T 26572-2011 standard.

×: the content of the toxic and hazardous substances or elements in the part is higher than the limit specified in GB/T 26572-2011 standard.

PART NAME	TOXIC AND HAZARDOUS SUBSTANCES OR ELEMENTS					
	Pb	Hg	Cd	Cr <sup>6+</sup>	PBB	PBDE
Display		O	O	O	O	O
Shell	O	O	O	O		
Circuit Board Assembly *		O	O	O	O	O
Wires	O	O	O	O	O	O
Metal Parts	O	O	O	O	O	O
Packaging Materials *	O	O	O	O	O	O
Remote Control		O	O	O	O	O
Speakers		O	O	O	O	O
Accessories *	O	O	O	O	O	O

\*: Packaging materials include packaging box, styrofoam, etc.;

\*: Circuit board assembly includes PCB and the electronic elements thereof;

\*: Other accessories include instruction manual.

The EFUP of the product is ten years. The pollution control label is shown right.



The EFUP is valid only when the user operates in the normal conditions specified in the manual herein.

### Waste Electrical and Electronic Products Recycling and Disposal Regulations

To protect the earth, if you do not need this product or its service life expires, please abide by your local Waste Electrical and Electronic Products Recycling and Disposal Regulations or send it to qualified local manufacturer for recycling.

# FCC Statement

Changes or modifications not expressly approved by the party responsible for compliance could void the user's authority to operate the equipment.

This equipment has been tested and found to comply with the limits for a Class B digital device, pursuant to Part 15 of the FCC Rules. These limits are designed to provide reasonable protection against harmful interference in a residential installation. This equipment generates uses and can radiate radio frequency energy and, if not installed and used in accordance with the instructions, may cause harmful interference to radio communications. However, there is no guarantee that interference will not occur in a particular installation. If this equipment does cause harmful interference to radio or television reception, which can be determined by turning the equipment off and on, the user is encouraged to try to correct the interference by one or more of the following measures:

Reorient or relocate the receiving antenna.

Increase the separation between the equipment and receiver.

Connect the equipment into an outlet on a circuit different from that to which the receiver is connected.

Consult the dealer or an experienced radio/TV technician for help

This device complies with part 15 of the FCC rules. Operation is subject to the following two conditions (1) this device may not cause harmful interference, and (2) this device must accept any interference received, including interference that may cause undesired operation.

## **FCC Radiation Exposure Statement:**

This equipment complies with FCC radiation exposure limits set forth for an uncontrolled environment. This equipment should be installed and operated with a minimum distance of 8 inches (20cm) between the radiator and your body.