

# User Manual

Rev 21.03

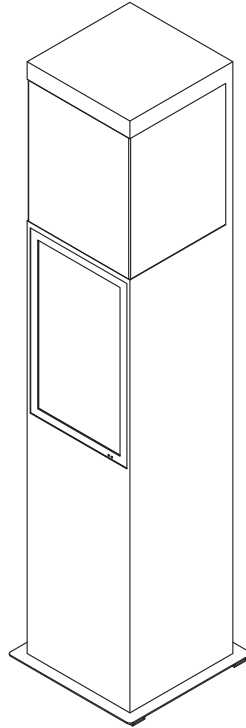

**Model:** DCNGDPL

**Description:** Digital Pedestal Display Case

**Scan QR code to visit  
the product page**



FCC ID: 2ASCB-DCNGDPL  
This device complies with Part 15 of the FCC Rules. Operation is subject to the following two conditions:  
(1) this device may not cause harmful interference, and  
(2) this device must accept any interference received, including interference that may cause undesired operation.  
Any changes/modifications to this equipment not approved by the party responsible for compliance could void the user's authority to operate the equipment.

## **Operating Instructions for Digital Signage**

Note: Before using the product, please read the instructions carefully!  
Do not attempt to disassemble this product. If the product does not work properly, please call our Customer Service Department at 1-844-221-3393.

## Contents

<b>Features .....</b>	<b>3</b>
<b>Safety Warnings and Precautions .....</b>	<b>3</b>
<b>Assembly and Connection .....</b>	<b>6</b>
Packing List.....	6
Description of Parts.....	7
Instruction of acrylic display case .....	8
Instruction of dimming LED ceiling light .....	10
<b>Remote Control of LCD Screen .....</b>	<b>11</b>
<b>Description of Basic Operation .....</b>	<b>12</b>
Power on/Standby .....	11
Interface and Home Screen .....	11
Description of Wallpaper Switch .....	12
File Manager .....	12
Local Settings .....	13
Status of Menu bar .....	15
<b>DiViEx APP Introduction .....</b>	<b>15</b>
System requirements .....	15
How to upload media files .....	15
Settings .....	17
Edit picture .....	17
Music .....	19
Factory Reset .....	19
Screen Rotation .....	20
Choose System Language .....	21
<b>Technical Specifications .....</b>	<b>22</b>
<b>Troubleshooting the Digital Signage.....</b>	<b>24</b>
<b>Cleaning and Maintenance .....</b>	<b>26</b>
<b>Names and Contents of Toxic and Hazardous Substances or Elements in the Product .....</b>	<b>27</b>

## Features

1. Embedded with Android 7.1 smart operating system and unique UI design, bringing you a more convenient operation and better visual experience.
2. Support USB mouse and keyboard, realizing easy manipulation like a computer. Using a mouse for set up is recommended.
3. Built-in Wi-Fi module, high capacity memory and high capacity cache, making it smoother to watch 1080P HD movies.
4. High-quality LCD screen as the display, no flicker, low radiation, greatly reducing eye fatigue, eye protection, high brightness, high contrast, and wide viewing angle; ultra-fast response time greatly reduces ghosting of fast-moving images.
5. Progressive image processing and industry-leading motion compensation technology improve the flickering and blurring in the edges of motion picture.
6. Dynamic contrast technology can significantly improve the clarity and contrast of various screens.
7. Multi-channel USB interfaces, supporting HD media streaming.

## Safety Warnings and Precautions

Thank you for purchasing the high-performance multi-functional LED backlight Digital Signage from Displays2go. We have considered the factors to ensure personal safety in product design and have tested rigorously at the factory. However, improper installation and use may result in electric shock and fire.

In order to safely use, maximize performance of the unit and extend the life of the product, please read and follow all instructions carefully before using the product.

Keep the instructions for future reference.

**We strongly recommend using a surge protector, or a power strip with internal circuit breaker to prevent damages to the digital signage.**

### Symbol Legends:

- ⚠ Warning: May cause personal injury or death
- 🚫 The operation is prohibited
- ⚠ Caution: May cause damage or property loss
- The operation must be executed

If any of the following occurs:

- Power outage or instable voltage.
- Abnormal sound or smell from the unit.
- AC power cord is damaged.
- Digital Signage is damaged due to drop, knock or impact.
- Any liquid or foreign matters fall into the enclosure.

 **Turn off the Digital Signage immediately, pull out the plug from the power outlet, and ask the authorized personnel for maintenance timely.**

- 🚫 **If coal gas or other flammable gas leaks, do not pull out the plug of the LCD Digital Signage or other electrical appliances; instead, turn off the gas valve immediately, and open the doors and windows quickly.**

**⚠ WARNING**







- ⊘ • Do not use power supply other than AC 110V, 60Hz.
  - Cut off the power supply before connecting or disconnecting any cables.
  - Do not place the Digital Signage on any instable positions, or else it may be damaged or cause fire.
  - Do not place the Digital Signage in the positions such as:
    1. The environment subject to direct strong sunlight, moisture, extreme temperature or too much dust;
    2. The environment with flammable or explosive materials;
    3. The environment with flammable or corrosive gases;
  - Do not use damaged or inappropriate power outlets and ensure that the plugs and outlets contact properly.
  - Do not let dust or metal deposits adhere to the plugs and outlets.
  - Do not damage the power cords:
    1. Do not modify the power cords;
    2. Do not place heavy objects on the power cords;
    3. Keep the power cords away from heat source;
    4. Do not pull the cord to remove the plug.
  - Do not connect too many plugs to one outlet in parallel, or else it may cause fire due to excessive power consumption.
  - Do not approach the Digital Signage with open flame (e.g. a lighted candle), or else it may cause electric shock or fire.
  - Do not put any sharp objects, metal or liquid into the vents or let them touch the signal terminals to avoid short circuit, product damage, and electric shock.
  - The openings in the enclosure are designed for ventilation and cooling, to ensure long time reliable running of components inside the enclosure and prevent overheating. Do not block the openings when place the unit.
- 
- ⊘ Do not touch the plugs with wet fingers, or else it will cause electric shock.
- Do not use the Digital Signage in stormy weather, especially when there is lightning; instead, please disconnect the power and antenna plugs to avoid lightning strike.
- ⊘ Do not disassemble the Digital Signage without permission, or else it may cause electric shock or fire. Please ask qualified technician for repair.

 CAUTION

- Do not let children climb onto the Digital Signage.
- Keep the small parts away from children to prevent them from swallowing.
- If the Digital Signage won't be used for a long time, please turn it off and pull out the power plug.
- To adjust the position of the Digital Signage, please disconnect all power cords and move slowly to avoid tip over.
- Do not scratch or knock the LCD with hard object, or twist and squeeze the LCD.
- Do not turn on the unit immediately when it is moved from a place with low temperature to high temperature, or else it will cause condensation and malfunction.
- Before cleaning the Digital Signage, please pull out the power plug; wipe with soft cloth; do not use industrial chemicals; prevent foreign matters from entering the machine. Improper cleaning (such as cleaning solution, water) may damage the product, erase the printed information, and even cause damage of the components if fluid flows in, resulting in machine failure.
- If the unit displays the same screen for a long time or the moving picture has fixed text or icon, it will leave ghosting on the screen and won't disappear when the unit is turned off; it is normal and isn't covered by the warranty.
- The power of the Digital Signage can be cut off by pulling out the plug.
- If the LCD screen ruptures and the liquid splashes on the skin, please rinse for 15 minutes with clean water immediately, and consult your doctor.
- To carry the Digital Signage with hands, please grab and hold the edges; do not apply pressure on the panel.
- Use the Digital Signage properly: Use in proper lighting conditions; insufficient lighting or long time watching will impair your eyesight.
- When the plug or coupler is used as disconnection device, it should be easy to operate the device.
- Insert the plug into the outlet properly, or else it may cause sparks and fire.
- The technical specifications printed herein and on the packaging are subject to change without prior notice. The Manual may be slightly different from actual operation, and the latter is applicable.

## Assembly and Connection

### Packing List

Accessory	Photo	Qty	Remark
AC Power cord		1	with Ground Pin
Remote Control for LCD Screen		1	
Remote Control for LED Ceiling Light		1	
Gloves		1	
Key		3	
User manual		1	

### Description of Parts

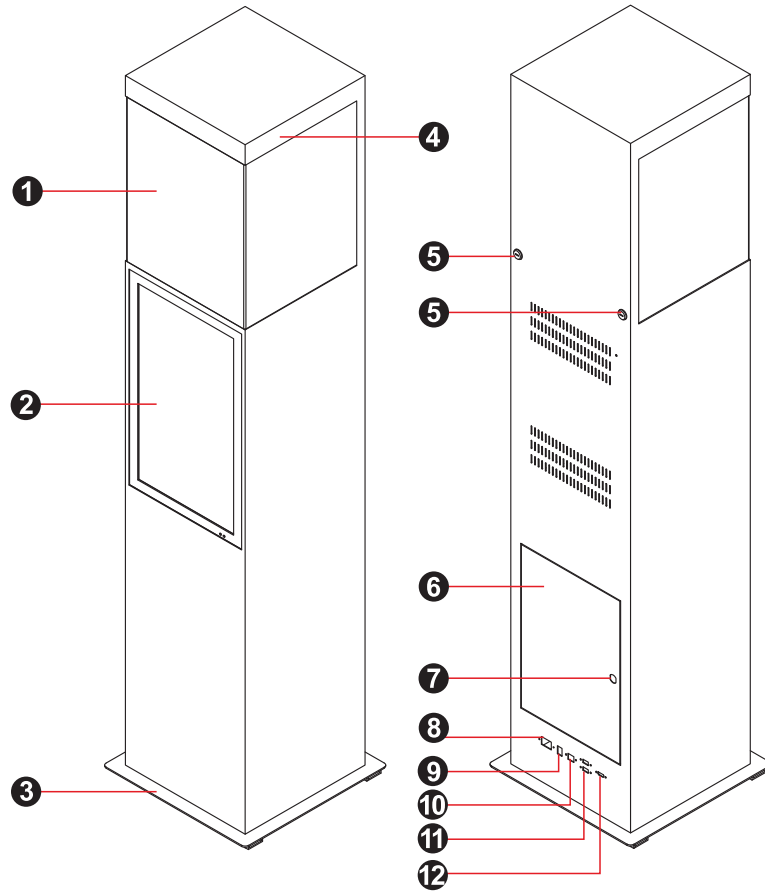

- 1 - Acrylic display case
- 2 - 21.5" LCD screen
- 3 - Steel base
- 4 - LED ceiling light
- 5 - Locks
- 6 - Door

- 7 - Lock
- 8 - AC power socket
- 9 - Power switch
- 10 - Ethernet port (RJ45 socket)
- 11 - USB port
- 12 - HDMI port

**CAUTION:** Disconnect the power plug before assembling or disassembling the unit!

Instruction of acrylic display case:

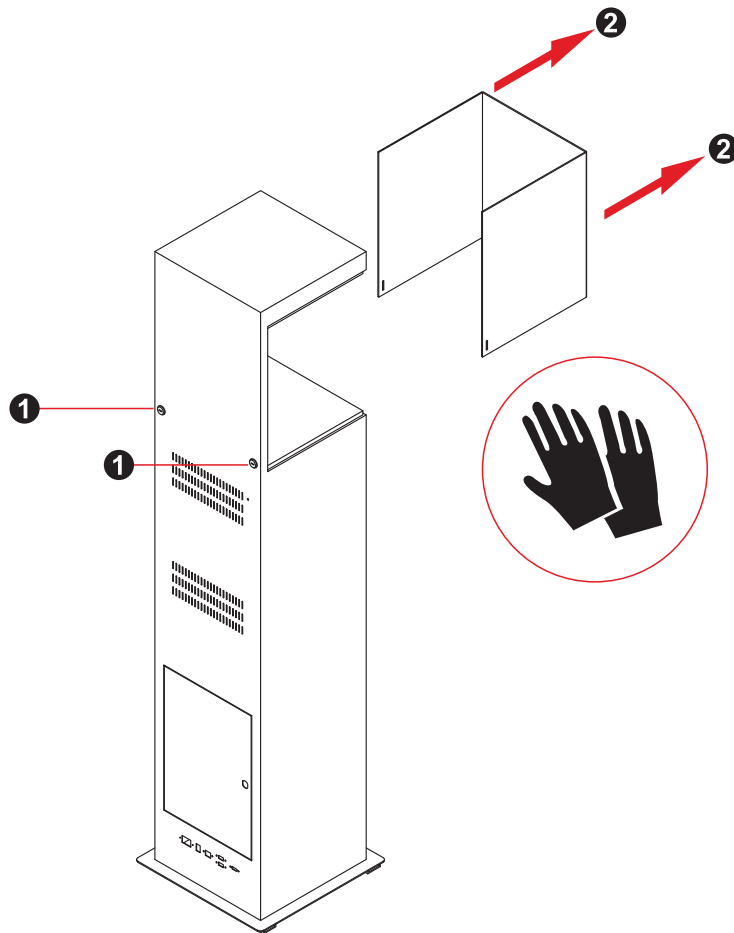

1. Use the attached key to open the acrylic case as shown in the figure 1.
2. Take out the acrylic case as shown in Figure 2.  
Note: To prevent fingerprints left on the clear acrylic case surface, please wear the white cotton gloves when operate.
3. Place the exhibits shown in the display area.



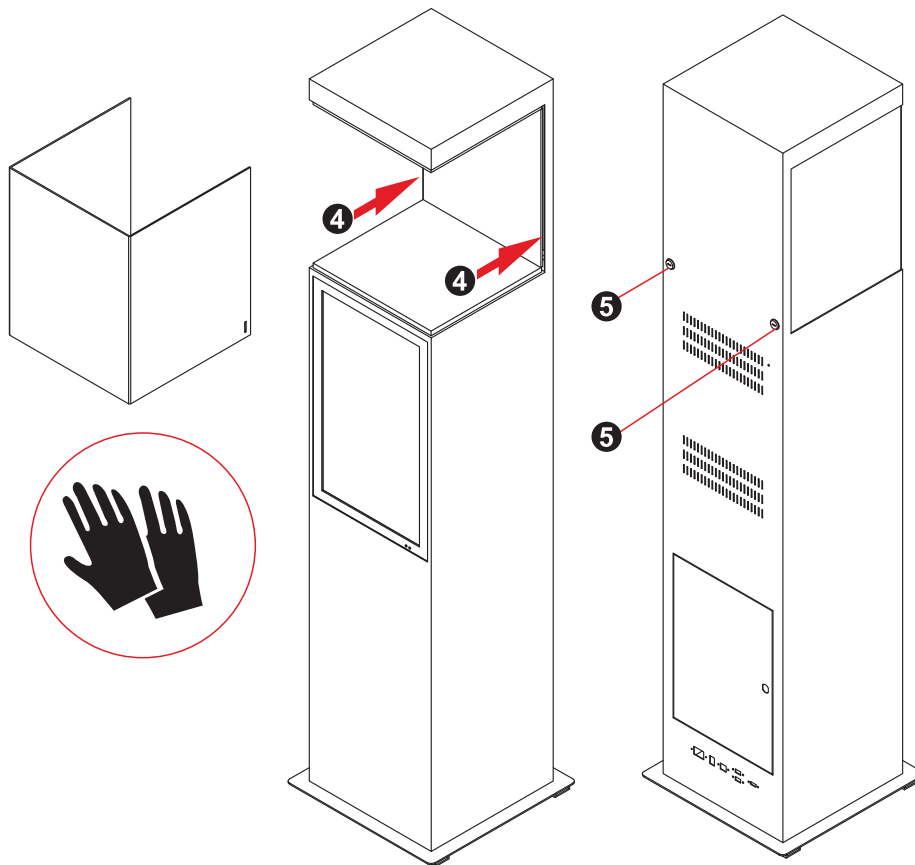

4. Put back the acrylic display case as shown in Figure 4.

**Note:** Acrylic case should be fully inserted into the slots on the left and right sides.

5. Lock the acrylic display case properly.

### Instruction of dimming LED ceiling light

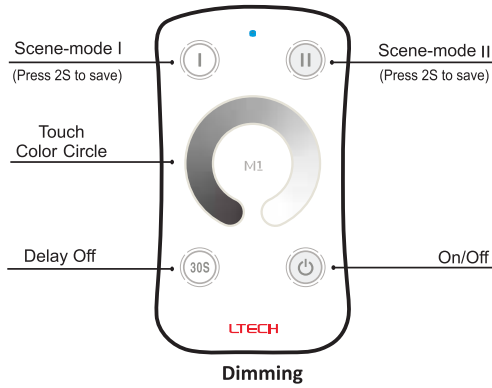

Model:	M1
Working Voltage:	3Vdc (battery CR2032)
Working Frequency:	433.92MHz
Remote Distance:	30m
Working Temp.:	-30°C~55°C
Weight(N.W.):	42g

#### Dimming

The user can adjust the brightness of the LED ceiling light by the attached remote. The operation is as follows:  
Before using, please remove the PET transparent insulating sheet under the battery of the remote control.

1. Press the on button.
2. Place the remote control aim at the LED ceiling light, and slide your finger to the "touch color circle" to adjust the brightness as you wish.

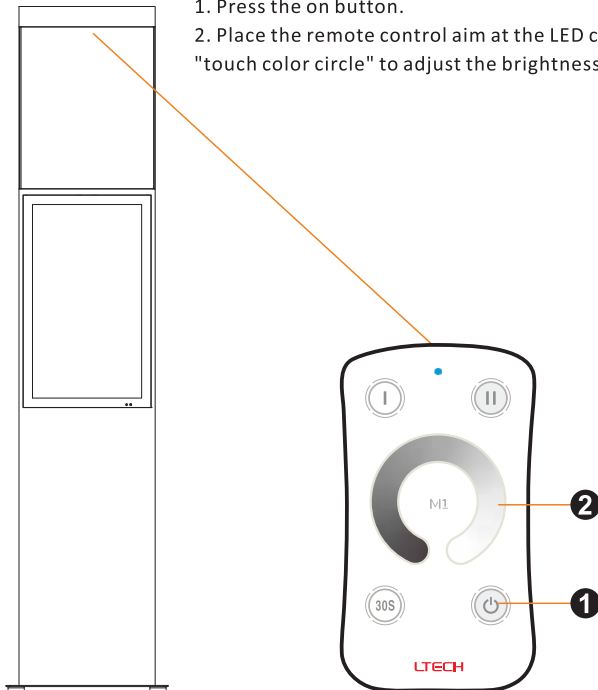

## Remote Control of the LCD Screen

















### Installing batteries for the remote control:

Remove the battery cover and insert two AAA batteries (1.5V). Ensure that the battery polarity matches the “+”/“-” marks in the battery compartment of the remote control.

### Precautions for using the remote control:

- Aim the remote control at the receiver window. Do not place any object between the remote control and the receiver window to avoid interference with the normal operation.
- Keep the remote control away from violent vibration. In addition, do not set or place the remote control in direct sunlight, or else the remote control may be deformed by heat.
- The remote control may be invalid when the receiver window of the unit is in direct sunlight or strong lighting; in this case, please adjust the angle of the lighting or the unit or approach the receiver window to use it.
- The distance of remote control will be shortened if the battery voltage is insufficient; in this case, please replace with new batteries; if the remote control won't be used for a long time or the batteries are run out, please take out the batteries to avoid corrosion due to battery leakage, which will damage the remote control.
- Do not use batteries of different types or mix new batteries with old ones. Always replace the batteries in pairs.
- Do not put the batteries in fire, or charge or disassemble them, or charge, short circuit, disassemble, heat or burn used batteries. Please dispose of waste batteries in accordance with local environmental regulations. Do not expose the batteries in overheated environments such as sunlight and fire.

### Remote control buttons:

	Power switch		Play programs; confirm selection
	To show the Source menu		Display indication
	Mute		Home page
	Turn down the volume		Back
	Turn up the volume		To show the main menu
	To move the cursor up		To set up OSD menu
	To move the cursor left		Input numbers
	To move the cursor right		
	To move the cursor down		









## Description of Basic Operation

### Power on/Standby

Insert the power plug into the outlet. If the Digital Signage has the switch button “I”, turn it on.  
In power on state, press the “⏻” button on the remote control, and the Digital Signage enters standby state.

### Interface and Home Screen

After power on, the machine will launch home screen, as shown below:

Icon	Function
	App Drawer
	Back
	Home page
	Background applications
	Sound -
	Sound +

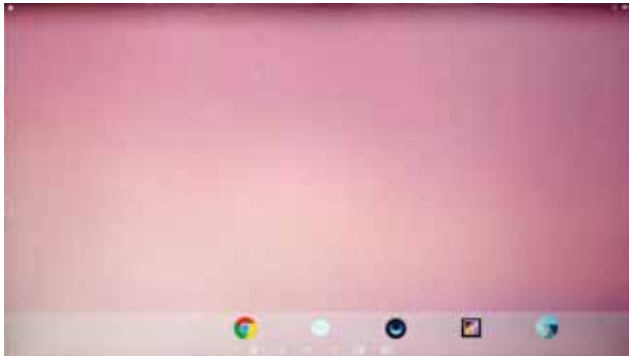

### Description of Wallpaper Switch

We suggest using a mouse to change the wallpaper.

Connect a mouse with the digital panel through USB port, then follow the steps below:

1. click "Setting"
2. At the setting menu, click "Display"
3. At the Display setting menu, click "Wallpaper", then choose a folder.
4. Then select an image you would like to set up as background.
5. Confirm the selection by clicking "Set wallpaper".

### File Manager

1. Click the Main Apps button "☰" in the Home page to enter the "APPS" menu interface (Fig. 1);
2. Click the "Explorer" icon in the "APPS" menu interface (Fig. 2) and enter "Explorer" menu (Fig. 3);
3. Click options in the "Explorer" menu to read the files from different devices.

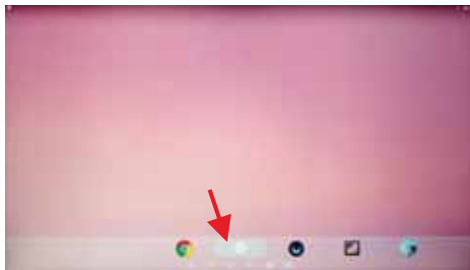

Fig. 1



Fig. 2



Fig. 3

### Local Settings

1. Click the App Drawer icon “☰” in the Home page to enter the “APPS” menu interface (Fig. 1);
2. Click the “Settings” icon (Fig. 1) and enter “Settings” menu (Fig. 2);
3. Click “Wi-Fi” and choose options then set up the WIFI connection (Fig. 3).



Fig. 1



Fig. 2



Fig. 3

### Description of Settings Interface (shown on the right)

Icon	Function
	WIFI switch
	Bluetooth
	Data usage
	Display
	Notifications
	Sound
	Apps
	Screenshot Setting
	Storage
	Battery
	Memory
	Users
	Location
	Security
	Accounts
	Google
	Languages & input
	Backup & reset
	Date & time

