



# TEST REPORT

## 47 CFR Part 15, Subpart C 15.247

Report Reference No.....: CTL2404222135-WF03

Compiled by: Happy Guo  
( position+printed name+signature) (File administrators)

Tested by: Jack Wang  
( position+printed name+signature) (Test Engineer)

Approved by: Ivan Xie  
( position+printed name+signature) (Manager)



Product Name.....: AUTO DIAGNOSE TABLET

Model/Type reference.....: ANCEL V5 HD

List Model(s).....: ANCEL V3, ANCEL V3 PRO, ANCEL V3 ELITE, ANCEL V3HD, ANCEL V310, ANCEL V320, ANCEL V330, ANCEL V340, ANCEL V350, ANCEL V360, ANCEL V370, ANCEL V380, ANCEL V390, ANCEL V5BT, ANCEL V5 ELITE, ANCEL V5 PRO

Trade Mark.....: ANCEL

FCC ID.....: 2ASC7TAB702

Applicant's name.....: OBDSpace TECHNOLOGY CO.,LTD

Address of applicant.....: Room D03, Building A, No.973, MinZhi Avenue LongHua district, Shenzhen City, China

Test Firm.....: Shenzhen CTL Testing Technology Co., Ltd.

Address of Test Firm.....: Floor 1-A, Baisha Technology Park, No.3011, Shahexi Road, Nanshan District, Shenzhen, China 518055

Test specification.....:

Standard.....: 47 CFR Part 15, Subpart C 15.247: Operation within the bands 902-928 MHz, 2400-2483.5 MHz and 5725-5850 MHz.

TRF Originator.....: Shenzhen CTL Testing Technology Co., Ltd.

Master TRF.....: Dated 2011-01

Date of receipt of test item.....: May 29, 2024

Date of Test Date.....: May 29, 2024-August 5, 2024

Date of Issue.....: August 6, 2024

Result.....: Pass

**Shenzhen CTL Testing Technology Co., Ltd. All rights reserved.**

This publication may be reproduced in whole or in part for non-commercial purposes as long as the Shenzhen CTL Testing Technology Co., Ltd. is acknowledged as copyright owner and source of the material. Shenzhen CTL Testing Technology Co., Ltd. takes no responsibility for and will not assume liability for damages resulting from the reader's interpretation of the reproduced material due to its placement and context.

# TEST REPORT

<b>Test Report No. :</b> CTL2404222135-WF03	August 6, 2024 Date of issue
---	---------------------------------

Equipment under Test : AUTO DIAGNOSE TABLET

Sample No : CTL2404222135

Model /Type : ANCEL V5 HD

Listed Models : ANCEL V3, ANCEL V3 PRO, ANCEL V3 ELITE, ANCEL V3HD, ANCEL V310, ANCEL V320, ANCEL V330, ANCEL V340, ANCEL V350, ANCEL V360, ANCEL V370, ANCEL V380, ANCEL V390, ANCEL V5BT, ANCEL V5 ELITE, ANCEL V5 PRO

**Applicant** : **OBDSpace TECHNOLOGY CO.,LTD**

Address : Room D03, Building A, No.973, MinZhi Avenue  
LongHua district, Shenzhen City, China

**Manufacturer** : **Shenzhen IDUTEX Tech Co., Ltd**

Address : Room 401, Building B11, Yintian Industrial Zone,  
Yantian, Xixiang, Baoan, Shenzhen, China

<b>Test result</b>	<b>Pass *</b>
--------------------	---------------

\* In the configuration tested, the EUT complied with the standards specified page 5.

The test results presented in this report relate only to the object tested.

This report shall not be reproduced, except in full, without the written approval of the issuing testing laboratory.



## Table of Contents

Page

<b>1. SUMMARY</b> .....	<b>5</b>
1.1. TEST STANDARDS .....	5
1.2. TEST DESCRIPTION .....	5
1.3. TEST FACILITY .....	6
1.4. STATEMENT OF THE MEASUREMENT UNCERTAINTY .....	6
<b>2. GENERAL INFORMATION</b> .....	<b>8</b>
2.1. ENVIRONMENTAL CONDITIONS .....	8
2.2. GENERAL DESCRIPTION OF EUT .....	8
2.3. DESCRIPTION OF TEST MODES AND TEST FREQUENCY .....	9
2.4. EQUIPMENTS USED DURING THE TEST .....	10
2.5. RELATED SUBMITTAL(S) / GRANT (S) .....	10
2.6. MODIFICATIONS .....	11
<b>3. TEST CONDITIONS AND RESULTS</b> .....	<b>12</b>
3.1. CONDUCTED EMISSIONS TEST .....	12
3.2. RADIATED EMISSIONS AND BAND EDGE .....	15
3.3. MAXIMUM CONDUCTED OUTPUT POWER .....	25
3.4. POWER SPECTRAL DENSITY .....	26
3.5. 6DB BANDWIDTH .....	27
3.6. OUT-OF-BAND EMISSIONS .....	28
3.7. ANTENNA REQUIREMENT .....	29
<b>4. TEST SETUP PHOTOS OF THE EUT</b> .....	<b>30</b>
<b>5. PHOTOS OF THE EUT</b> .....	<b>30</b>

# 1. SUMMARY

## 1.1. TEST STANDARDS

The tests were performed according to following standards:

[47 CFR Part 15, Subpart C 15.247](#): Frequency Hopping, Direct Spread Spectrum and Hybrid Systems that are in operation within the bands of 902-928 MHz, 2400-2483.5 MHz, and 5725-5850 MHz

[ANSI C63.10: 2013](#): American National Standard for Testing Unlicensed Wireless Devices

[KDB 558074 D01 15.247 Meas Guidance v05r02](#) : Guidance for Performing Compliance Measurements on Digital Transmission Systems (DTS) Operating Under §15.247.

## 1.2. Test Description

47 CFR Part 15, Subpart C 15.247		
47 CFR Part 15, Subpart C 15.207	AC Power Conducted Emission	PASS
47 CFR Part 15, Subpart C 15.247(a)(2)	6dB Bandwidth	PASS
47 CFR Part 15, Subpart C 15.247(d)	Spurious RF Conducted Emission	PASS
47 CFR Part 15, Subpart C 15.247(b)	Maximum Conducted Output Power	PASS
47 CFR Part 15, Subpart C 15.247(e)	Power Spectral Density	PASS
47 CFR Part 15, Subpart C 15.109/ 15.205/ 15.209	Radiated Emissions	PASS
47 CFR Part 15, Subpart C 15.247(d)	Band Edge	PASS
47 CFR Part 15, Subpart C 15.203/15.247 (b)	Antenna Requirement	PASS

## 1.3. Test Facility

### 1.3.1 Address of the test laboratory

Shenzhen CTL Testing Technology Co.,Ltd.

Floor 1-A, Baisha Technology Park, No. 3011, Shahexi Road, Nanshan, Shenzhen 518055 China

There is one 3m semi-anechoic chamber and two line conducted labs for final test. The Test Sites meet the requirements in documents ANSI C63.10 and CISPR 22/EN 55022 requirements.

### 1.3.2 Laboratory accreditation

The test facility is recognized, certified, or accredited by the following organizations:

#### **CNAS-Lab Code: L7497**

Shenzhen CTL Testing Technology Co., Ltd. has been assessed and proved to be in compliance with CNAS-CL01 Accreditation Criteria for Testing and Calibration Laboratories (identical to ISO/IEC 17025: 2017 General Requirements) for the Competence of Testing and Calibration Laboratories.

#### **A2LA-Lab Cert. No. 4343.01**

Shenzhen CTL Testing Technology Co., Ltd, EMC Laboratory has been accredited by A2LA for technical competence in the field of electrical testing, and proved to be in compliance with ISO/IEC 17025: 2017 General Requirements for the Competence of Testing and Calibration Laboratories and any additional program requirements in the identified field of testing.

#### **IC Registration No.: 9618B**

#### **CAB identifier: CN0041**

The 3m alternate test site of Shenzhen CTL Testing Technology Co., Ltd. EMC Laboratory has been registered by Innovation, Science and Economic Development Canada to test to Canadian radio equipment requirements with Registration No.: 9618B.

#### **FCC-Registration No.: 399832**

#### **Designation No.: CN1216**

Shenzhen CTL Testing Technology Co., Ltd. EMC Laboratory has been registered and fully described in a report filed with the (FCC) Federal Communications Commission. The acceptance letter from the FCC is maintained in our files. Registration 399832.

## 1.4. Statement of the measurement uncertainty

The data and results referenced in this document are true and accurate. The reader is cautioned that there may be errors within the calibration limits of the equipment and facilities. The measurement uncertainty was calculated for all measurements listed in this test report acc. to CISPR 16 - 4 "Specification for radio disturbance and immunity measuring apparatus and methods – Part 4: Uncertainty in EMC Measurements" and is documented in the Shenzhen CTL Testing Technology Co., Ltd. quality system acc. to DIN EN ISO/IEC 17025. Furthermore, component and process variability of devices similar to that tested may result in additional deviation. The manufacturer has the sole responsibility of continued compliance of the device.

Hereafter the best measurement capability for CTL laboratory is reported:

Test	Measurement Uncertainty	Notes
Transmitter power Radiated	$\pm 2.20$ dB	(1)
Radiated Emission 9KHz~30MHz	$\pm 3.66$ dB	(1)
Radiated Emission 30~1000MHz	$\pm 4.08$ dB	(1)
Radiated Emission Above 1GHz	$\pm 4.32$ dB	(1)
DTS Bandwidth	$\pm 1.9\%$	(1)
Maximum Conducted Output Power	$\pm 1.18$ dB	(1)
Maximum Power Spectral Density Level	$\pm 0.98$ dB	(1)
Band-edge	$\pm 1.21$ dB	(1)
Unwanted Emissions In Non-restricted Freq Bands	9kHz-7GHz: $\pm 1.09$ dB 7GHz-26.5GHz: $\pm 3.27$ dB	(1)

- (1) This uncertainty represents an expanded uncertainty expressed at approximately the 95% confidence level using a coverage factor of  $k=1.96$ .

## 2. GENERAL INFORMATION

### 2.1. Environmental conditions

During the measurement the environmental conditions were within the listed ranges:

Normal Temperature:	25°C
Relative Humidity:	55 %
Air Pressure:	101 kPa

### 2.2. General Description of EUT

Product Name:	AUTO DIAGNOSE TABLET
Model/Type reference:	ANCEL V5 HD
Power supply:	DC 3.87V from Battery or DC 5V from Adapter
Adapter information	MODEL:JB-006-01 Input:100-240V~50/60Hz 0.3A MAX Output:5V===2000mA
<b>2.4G WIFI</b>	
Supported type:	802.11b/802.11g/802.11n(H20)/802.11n(H40)
Modulation:	802.11b: DSSS 802.11g/802.11n(H20)/802.11n(H40): OFDM
Operation frequency:	802.11b/802.11g/802.11n(H20): 2412MHz~2462MHz 802.11n(H40): 2422MHz~2452MHz
Channel number:	802.11b/802.11g/802.11n(H20): 11 802.11n(H40): 7
Channel separation:	802.11b/802.11g/802.11n(H20)/802.11n(H40)
Antenna type:	PIFA Antenna
Antenna gain:	1.89dBi

Note1: For more details, please refer to the user's manual of the EUT.

Note2: Antenna gain provided by the applicant.

Note3: This report is for 2.4G WIFI only.



## 2.3. Description of Test Modes and Test Frequency

The Applicant provides communication tools software to control the EUT for staying in continuous transmitting (Duty Cycle more than 98%) and receiving mode for testing.

There are 11 channels provided to the EUT and Channel 01/03/06/09/11 were selected for WIFI test.

### Operation Frequency WIFI :

Channel	Frequency(MHz)	Channel	Frequency(MHz)
<b>1</b>	<b>2412</b>	8	2447
2	2417	<b>9</b>	<b>2452</b>
<b>3</b>	<b>2422</b>	10	2457
4	2427	<b>11</b>	<b>2462</b>
5	2432		
<b>6</b>	<b>2437</b>		
7	2442		

Note: The line display in grey were the channel selected for testing

### Data Rate Used:

Preliminary tests were performed in different data rate to find the worst radiated emission. The data rate shown in the table below is the worst-case rate with respect to the specific test item. Investigation has been done on all the possible configurations for searching the worst cases. The following table is a list of the test modes shown in this test report.

Test Items	Mode	Data Rate	Channel
Maximum Conducted Output Power Power Spectral Density 6dB Bandwidth Spurious RF conducted emission Radiated Emission 9kHz~1GHz& Radiated Emission 1GHz~10th Harmonic	11b/DSSS	1 Mbps	1/6/11
	11g/OFDM	6 Mbps	1/6/11
	11n(20MHz)/OFDM	6.5Mbps	1/6/11
	11n(40MHz)/OFDM	13.5Mbps	3/6/9
Band Edge	11b/DSSS	1 Mbps	1/11
	11g/OFDM	6 Mbps	1/11
	11n(20MHz)/OFDM	6.5Mbps	1/11
	11n(40MHz)/OFDM	13.5Mbps	3/9

## 2.4. Equipments Used during the Test

Conducted Emission						
Test Equipment	Manufacturer	Model No.	Serial No.	Previous calibration	Last Cal.	Cal.Due
EMI Test Receiver	ROHDE & SCHWARZ	ESCI	1166.5950.03	2023/05/04	2024/04/30	2025/04/29
LISN	ROHDE & SCHWARZ	ESH2-Z5	860014/010	2023/05/04	2024/04/30	2025/04/29
Limitator	ROHDE & SCHWARZ	ESH3-Z2	100408	2023/05/04	2024/04/30	2025/04/29
Software:						
Name of Software:			Version:			
ES-K1			V1.71			

Radiated Emission						
Test Equipment	Manufacturer	Model No.	Serial No.	Previous calibration	Last Cal.	Cal.Due
Active Loop Antenna	Da Ze	ZN30900A	/	2021/05/13	2024/04/30	2025/04/29
Double cone logarithmic antenna	Schwarzbeck	VULB 9168	824	/	2023/02/13	2026/02/12
Horn Antenna	Sunol Sciences Corp.	DRH-118	A062013	/	2021/12/23	2024/12/22
Horn Antenna	Ocean Microwave	OBH100400	26999002	/	2021/12/22	2024/12/21
Amplifier	MRT-AP01M06	MRT	S-001	2023/05/04	2024/04/30	2025/04/29
Amplifier	Agilent	8449B	3008A02306	2023/05/04	2024/04/30	2025/04/29
Amplifier	Brief&Smart	LNA-4018	2104197	2023/05/05	2024/05/03	2025/05/02
EMI Test Receiver	ROHDE & SCHWARZ	ESCI	1166.5950.03	2023/05/04	2024/04/30	2025/04/29
Spectrum Analyzer	RS	FSP	1164.4391.38	2023/05/05	2024/05/03	2025/05/02
Software:						
Name of Software:			Version:			
EZ_EMC(Below 1GHz)			V1.1.4.2			
EZ_EMC(Above 1GHz)			V1.1.4.2			

RF Conducted						
Test Equipment	Manufacturer	Model No.	Serial No.	Previous calibration	Last Cal.	Cal.Due
Spectrum Analyzer	Keysight	N9020A	MY53420874	2023/05/04	2024/05/01	2025/04/30
Temperature/Humidity Meter	Ji Yu	MC501	/	2023/05/09	2024/05/04	2025/05/03
Software:						
Name of Software:			Version:			
TST-PASS			V2.0			

## 2.5. Related Submittal(s) / Grant (s)

This submittal(s) (test report) is intended to comply with Section 15.247 of the FCC Part 15, Subpart C Rules.

## 2.6. Modifications

No modifications were implemented to meet testing criteria.

### 3. TEST CONDITIONS AND RESULTS

#### 3.1. Conducted Emissions Test

##### LIMIT

FCC CFR Title 47 Part 15 Subpart C Section 15.207

Frequency range (MHz)	Limit (dBuV)	
	Quasi-peak	Average
0.15-0.5	66 to 56*	56 to 46*
0.5-5	56	46
5-30	60	50

\* Decreases with the logarithm of the frequency.

##### TEST CONFIGURATION

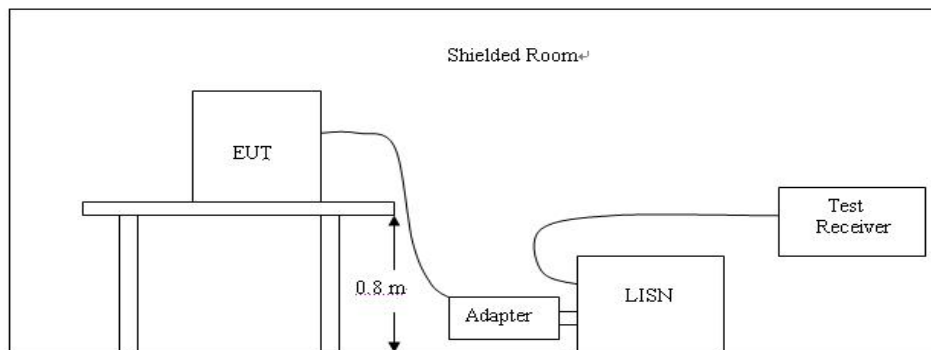

##### TEST PROCEDURE

1. The equipment was set up as per the test configuration to simulate typical actual usage per the user's manual. The EUT is a bObsweep Pet Hair Vision Plus Robot Vacuum Cleaner op system; a wooden table with a height of 0.8 meters is used and is placed on the ground plane as per ANSI C63.10:2013.
2. Support equipment, if needed, was placed as per ANSI C63.10:2013.
3. All I/O cables were positioned to simulate typical actual usage as per ANSI C63.10:2013.
4. The adapter received AC120V/60Hz power through a Line Impedance Stabilization Network (LISN) which supplied power source and was grounded to the ground plane.
5. All support equipments received AC power from a second LISN, if any.
6. The EUT test program was started. Emissions were measured on each current carrying line of the EUT using a spectrum Analyzer / Receiver connected to the LISN powering the EUT. The LISN has two monitoring points: Line 1 (Hot Side) and Line 2 (Neutral Side). Two scans were taken: one with Line 1 connected to Analyzer / Receiver and Line 2 connected to a 50 ohm load; the second scan had Line 1 connected to a 50 ohm load and Line 2 connected to the Analyzer / Receiver.
7. Analyzer / Receiver scanned from 150 KHz to 30MHz for emissions in each of the test modes.
8. During the above scans, the emissions were maximized by cable manipulation.

**TEST RESULTS**

Remark:802.11b/802.11g/802.11n(H20)/802.11n(H40) mode all have been tested ,only worse case is reported.

Test Mode	WIFI	Line:	L				
<p><b>SCAN TABLE: "Voltage (9K-30M)FIN"</b>                      Short Description: 150K-30M Voltage</p>							
<p>x x xMES CTL240620161_fin</p>							
<p><b>MEASUREMENT RESULT: "CTL240620161_fin"</b></p>							
<p>6/25/2024 9:42AM</p>							
Frequency	Level	Transd	Limit	Margin	Detector	Line	PE
MHz	dBµV	dB	dBµV	dB			
0.487500	48.60	10.0	56	7.6	QP	L1	GND
0.510000	47.70	10.0	56	8.3	QP	L1	GND
0.600000	40.30	10.0	56	15.7	QP	L1	GND
0.960000	43.10	10.1	56	12.9	QP	L1	GND
1.027500	43.10	10.1	56	12.9	QP	L1	GND
1.221000	37.70	10.1	56	18.3	QP	L1	GND
<p><b>MEASUREMENT RESULT: "CTL240620161_fin2"</b></p>							
<p>6/25/2024 9:42AM</p>							
Frequency	Level	Transd	Limit	Margin	Detector	Line	PE
MHz	dBµV	dB	dBµV	dB			
0.312000	32.50	10.0	50	17.4	AV	L1	GND
0.496500	37.50	10.0	46	8.6	AV	L1	GND
0.501000	39.40	10.0	46	6.6	AV	L1	GND
0.703500	32.10	10.0	46	13.9	AV	L1	GND
0.964500	28.90	10.1	46	17.1	AV	L1	GND
1.207500	30.40	10.1	46	15.6	AV	L1	GND

Test Mode	WIFI	Line:	N
-----------	------	-------	---

**SCAN TABLE: "Voltage (9K-30M)FIN"**  
 Short Description: 150K-30M Voltage

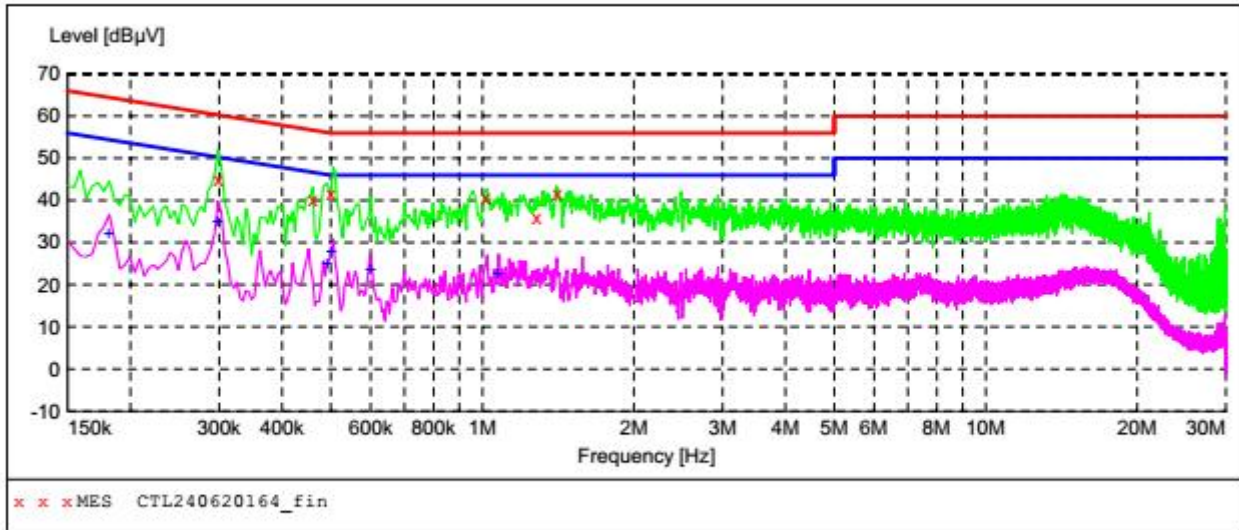

**MEASUREMENT RESULT: "CTL240620164\_fin"**

6/25/2024 9:46AM

Frequency MHz	Level dBµV	Transd dB	Limit dBµV	Margin dB	Detector	Line	PE
0.298500	44.80	10.0	60	15.5	QP	N	GND
0.460500	40.00	10.0	57	16.7	QP	N	GND
0.501000	41.40	10.0	56	14.6	QP	N	GND
1.018500	40.60	10.1	56	15.4	QP	N	GND
1.284000	35.70	10.1	56	20.3	QP	N	GND
1.410000	41.40	10.1	56	14.6	QP	N	GND

**MEASUREMENT RESULT: "CTL240620164\_fin2"**

6/25/2024 9:46AM

Frequency MHz	Level dBµV	Transd dB	Limit dBµV	Margin dB	Detector	Line	PE
0.181500	31.90	10.0	54	22.5	AV	N	GND
0.298500	35.20	10.0	50	15.1	AV	N	GND
0.492000	24.90	10.0	46	21.2	AV	N	GND
0.501000	27.70	10.0	46	18.3	AV	N	GND
0.600000	23.40	10.0	46	22.6	AV	N	GND
1.077000	22.50	10.1	46	23.5	AV	N	GND

### 3.2. Radiated Emissions and Band Edge

#### Limit

For intentional device, according to § 15.209(a), the general requirement of field strength of radiated emission out of authorized band shall not exceed the following table at a 3 meters measurement distance.

In addition, radiated emissions which fall in the restricted bands, as defined in §15.205(a), must also comply with the radiated emission limits specified in §15.209(a)

Radiated emission limits

Frequency (MHz)	Distance (Meters)	Radiated (dB $\mu$ V/m)	Radiated ( $\mu$ V/m)
0.009-0.49	3	$20\log(2400/F(\text{KHz}))+40\log(300/3)$	$2400/F(\text{KHz})$
0.49-1.705	3	$20\log(24000/F(\text{KHz}))+40\log(30/3)$	$24000/F(\text{KHz})$
1.705-30	3	$20\log(30)+40\log(30/3)$	30
30-88	3	40.0	100
88-216	3	43.5	150
216-960	3	46.0	200
Above 960	3	54.0	500

#### TEST CONFIGURATION

(A) Radiated Emission Test Set-Up, Frequency Below 30MHz

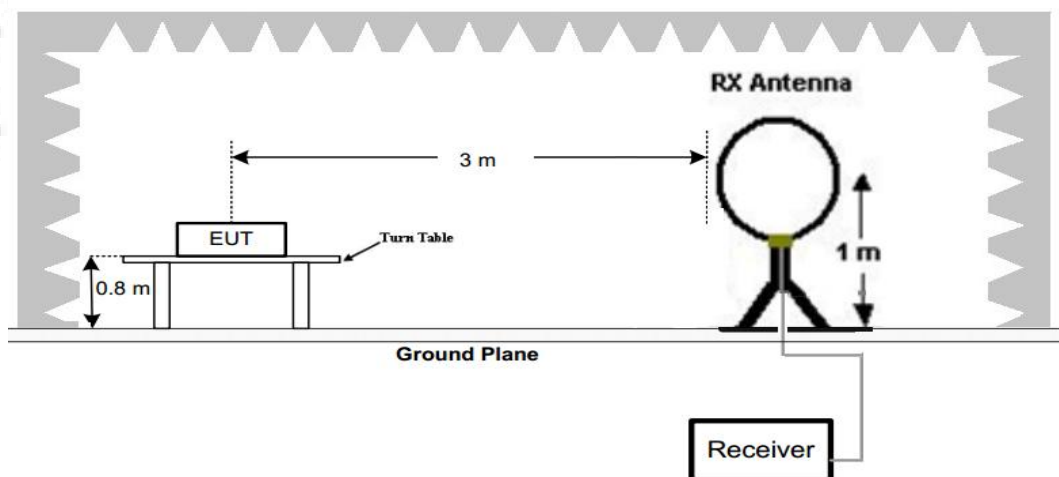

(B) Radiated Emission Test Set-Up, Frequency below 1000MHz

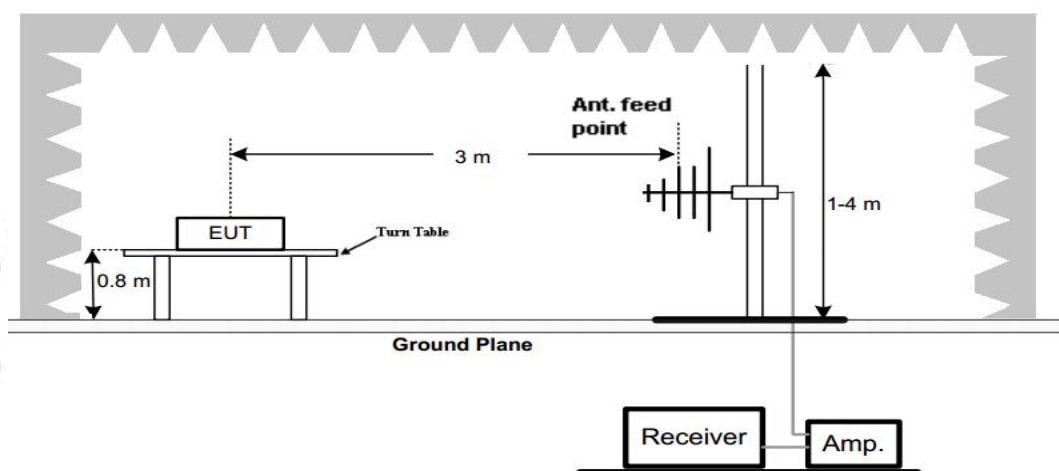

(C) Radiated Emission Test Set-Up, Frequency above 1000MHz

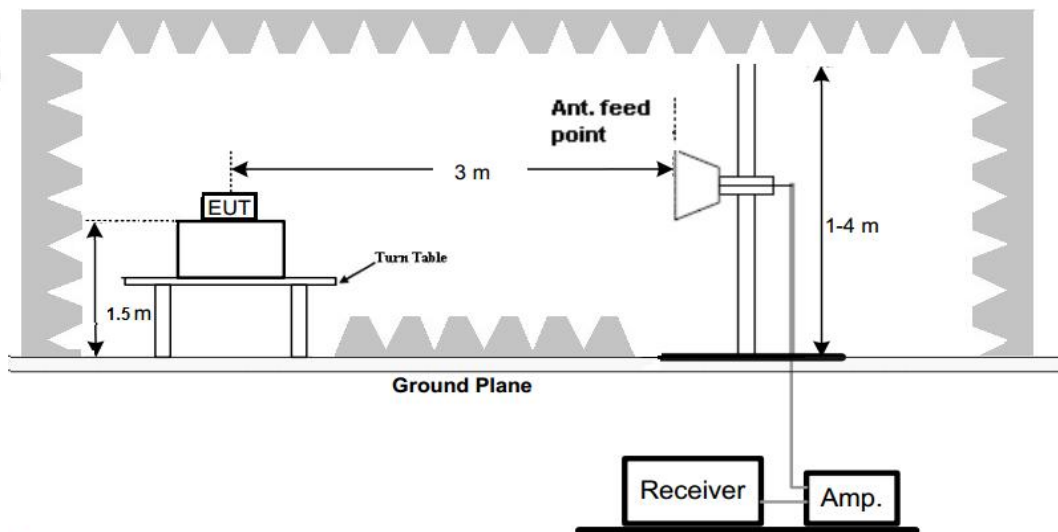

### Test Procedure

1. Below 1GHz measurement the EUT is placed on a turntable which is 0.8m above ground plane, and above 1GHz measurement EUT was placed on a low permittivity and low loss tangent turn table which is 1.5m above ground plane.
2. Maximum procedure was performed by raising the receiving antenna from 1m to 4m and rotating the turn table from 0° to 360° to acquire the highest emissions from EUT
3. And also, each emission was to be maximized by changing the polarization of receiving antenna both horizontal and vertical.
4. Repeat above procedures until all frequency measurements have been completed.
5. The EUT was pretested with 3 orientations placed on the table for the radiated emission measurement –X, Y, and Z-plane. The X-plane results were found as the worst case and were shown in this report.

### TEST RESULTS

Remark:

1. All three channels (lowest/middle/highest) of each mode were measured below 1GHz and recorded worst case at 802.11b low channel.
2. All three channels (lowest/middle/highest) of each mode were measured above 1GHz and recorded worst case at 802.11b mode.
3. Radiated emission test from 9 KHz to 10th harmonic of fundamental was verified, Found the emission level are attenuated 20dB below the limits from 9 kHz to 30MHz, so it does not recorded in report.



For 30MHz-1GHz

Test mode:	WIFI	Polarization:	Horizontal
------------	------	---------------	------------



Shenzhen CTL Testing Technology Co., Ltd  
Tel: +86-755-89486194

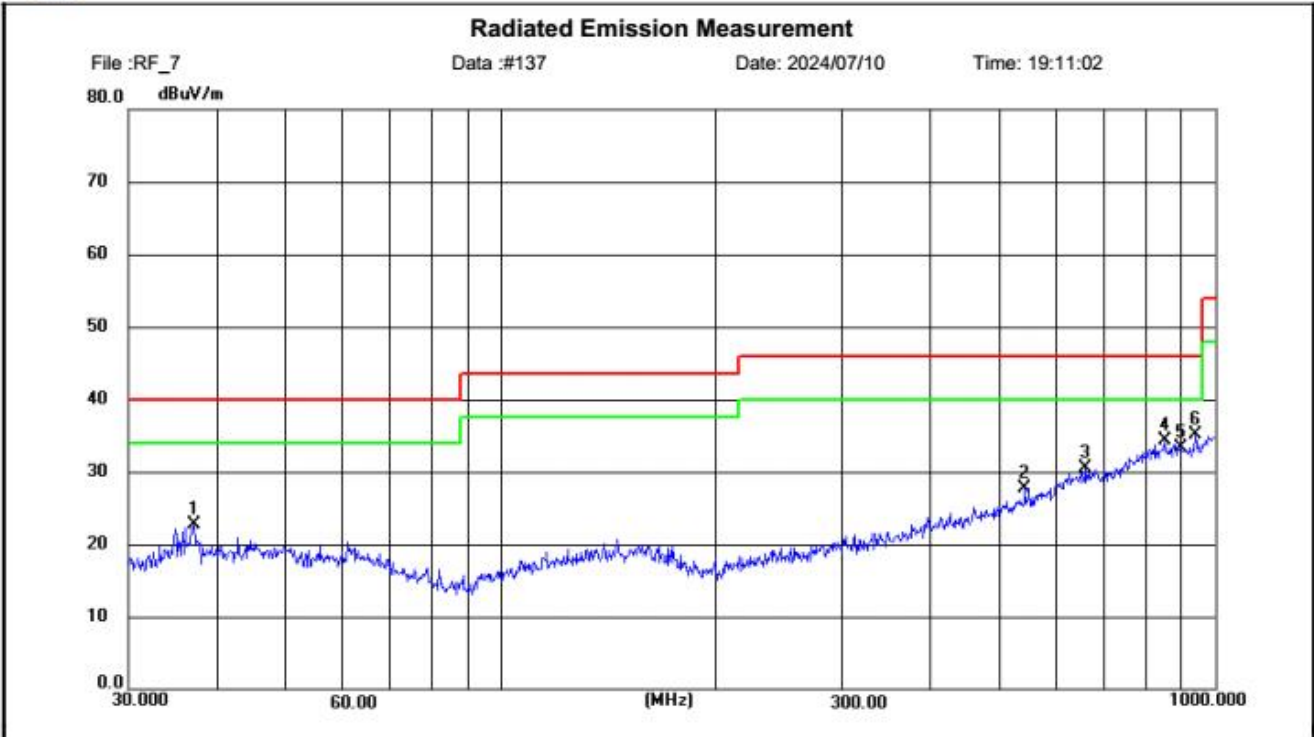

Site LAB Chamber 2      Polarization: **Horizontal**      Temperature: 25(C)  
Limit: FCC Part15 RE-Class C\_30-1000MHz      Power:      Humidity: 50 %  
EUT:      Distance: 3m  
M/N: ANCEL V5 HD  
Mode: WIFI2.4G 2412MHz  
Note: OBDSpace TECHNOLOGY Co., LTD

No.	Frequency (MHz)	Reading (dBuV)	Factor (dB/m)	Level (dBuV/m)	Limit (dBuV/m)	Margin (dB)	Detector	Height (cm)	Azimuth (deg.)	P/F	Remark
1	37.1550	8.89	13.88	22.77	40.00	17.23	peak	100	121	P	
2	541.8473	7.67	20.08	27.75	46.00	18.25	peak	100	341	P	
3	660.2816	7.90	22.59	30.49	46.00	15.51	peak	100	351	P	
4	853.6504	8.01	26.31	34.32	46.00	11.68	peak	100	184	P	
5	894.2485	6.88	26.39	33.27	46.00	12.73	peak	100	257	P	
6	939.6560	7.94	27.09	35.03	46.00	10.97	peak	100	90	P	

<b>Test mode:</b>	<b>WIFI</b>	<b>Polarization:</b>	<b>Vertical</b>
-------------------	-------------	----------------------	-----------------



Shenzhen CTL Testing Technology Co., Ltd  
Tel: +86-755-89486194

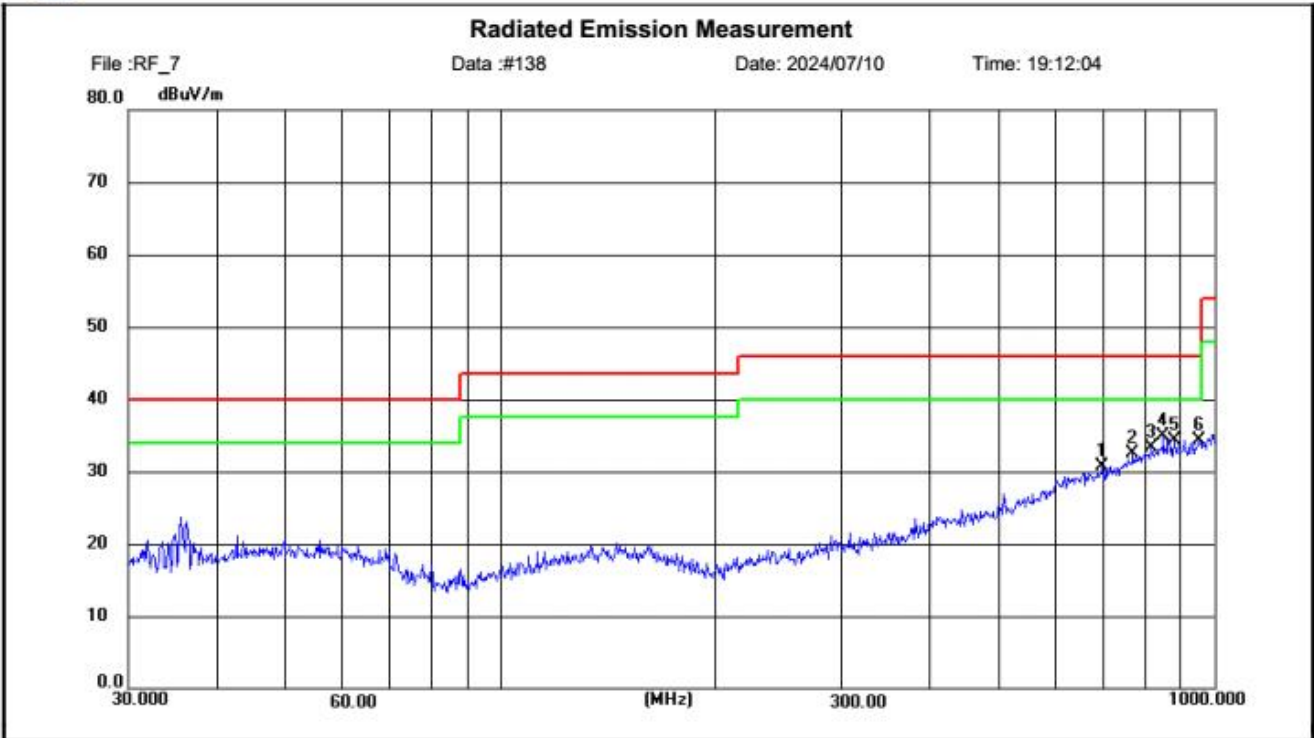

Site LAB Chamber 2	Polarization: <b>Vertical</b>	Temperature: 25(C)
Limit: FCC Part15 RE-Class C_30-1000MHz	Power:	Humidity: 50 %
EUT:	Distance: 3m	
M/N: ANCEL V5 HD		
Mode: WIFI2.4G 2412MHz		
Note: OBDSpace TECHNOLOGY Co., LTD		

No.	Frequency (MHz)	Reading (dBuV)	Factor (dB/m)	Level (dBuV/m)	Limit (dBuV/m)	Margin (dB)	Detector	Height (cm)	Azimuth (deg.)	P/F	Remark
1	698.9981	8.00	22.76	30.76	46.00	15.24	peak	100	271	P	
2	770.0972	7.69	24.80	32.49	46.00	13.51	peak	100	250	P	
3	818.1166	7.43	25.97	33.40	46.00	12.60	peak	100	156	P	
4	850.2896	8.61	26.24	34.85	46.00	11.15	peak	100	30	P	
5	880.6344	8.25	26.00	34.25	46.00	11.75	peak	100	302	P	
6	955.0195	7.11	27.12	34.23	46.00	11.77	peak	100	177	P	

For 1GHz to 25GHz

Test mode:	WIFI	Polarization:	Horizontal
------------	------	---------------	------------



Shenzhen CTL Testing Technology Co., Ltd  
Tel: +86-755-89486194

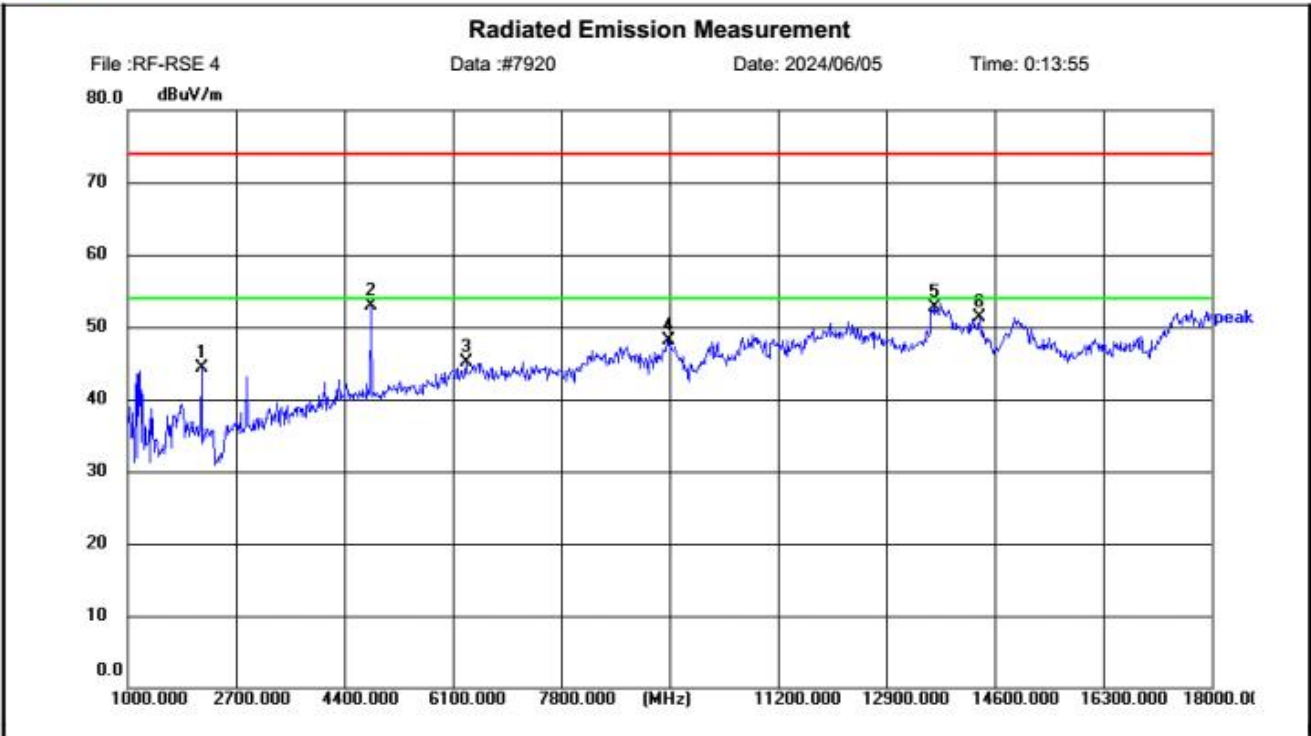

Site LAB Chamber 2  
 Limit: FCC Part15 RE-Class C\_Above 1GHz\_PK  
 EUT:  
 M/N: ANCEL V5 HD  
 Mode: WIFI2.4G 2412MHz TX  
 Note: OBDSpace TECHNOLOGY Co., LTD

Polarization: **Horizontal**  
 Power:  
 Distance: 3m

Temperature: 25(C)  
 Humidity: 50 %

No.	Frequency (MHz)	Reading (dBuV)	Factor (dB/m)	Level (dBuV/m)	Limit (dBuV/m)	Margin (dB)	Detector	Height (cm)	Azimuth (deg.)	P/F	Remark
1	2160.250	62.28	-17.88	44.40	74.00	29.60	peak	150	349	P	
2	4822.875	60.89	-8.05	52.84	74.00	21.16	peak	150	42	P	
3	6314.625	49.91	-4.73	45.18	74.00	28.82	peak	150	142	P	
4	9483.000	47.84	0.29	48.13	74.00	25.87	peak	150	67	P	
5	13669.250	48.75	3.92	52.67	74.00	21.33	peak	150	71	P	
6	14370.500	48.64	2.69	51.33	74.00	22.67	peak	150	281	P	

<b>Test mode:</b>	<b>WIFI</b>	<b>Polarization:</b>	<b>Vertical</b>
-------------------	-------------	----------------------	-----------------



Shenzhen CTL Testing Technology Co., Ltd  
Tel: +86-755-89486194

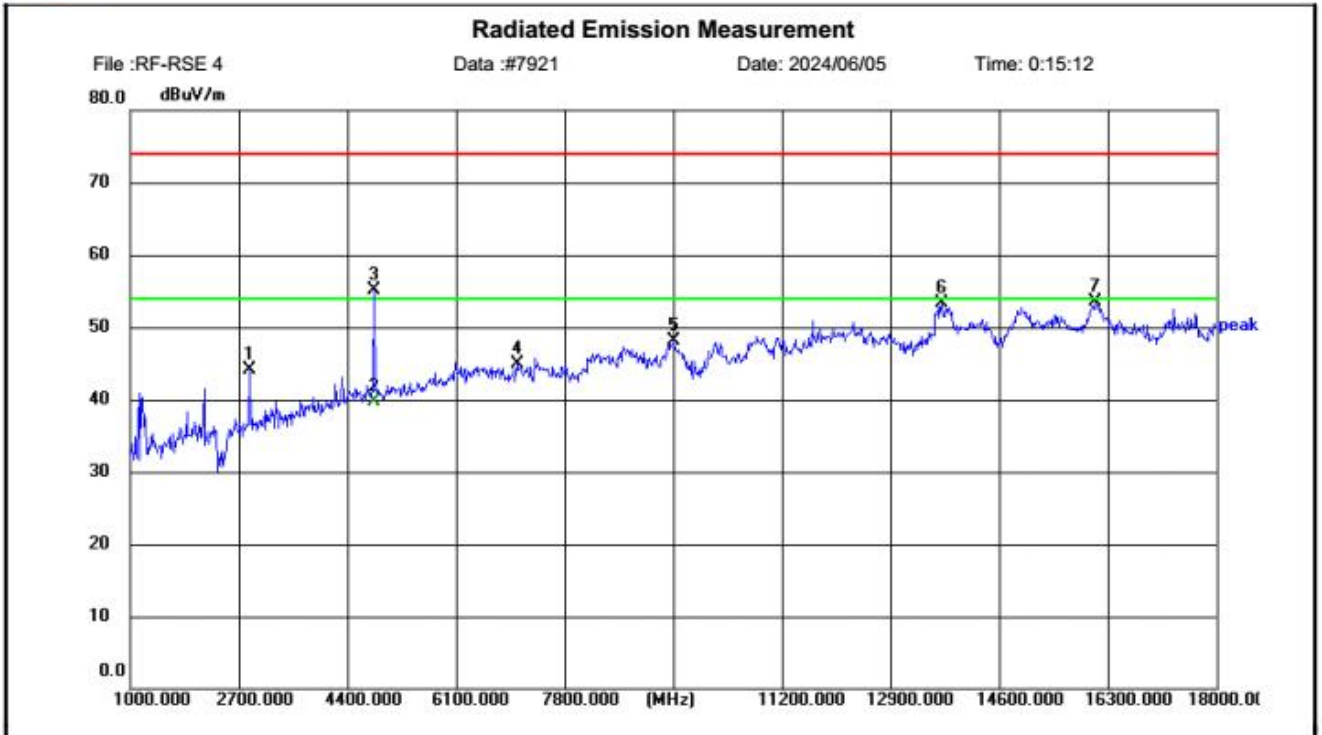

Site LAB Chamber 2      Polarization: **Vertical**      Temperature: 25(C)  
Limit: FCC Part15 RE-Class C\_Above 1GHz\_PK      Power:      Humidity: 50 %  
EUT:      Distance: 3m  
M/N: ANCEL V5 HD  
Mode: WIFI2.4G 2412MHz TX  
Note: OBDSpace TECHNOLOGY Co., LTD

No.	Frequency (MHz)	Reading (dBuV)	Factor (dB/m)	Level (dBuV/m)	Limit (dBuV/m)	Margin (dB)	Detector	Height (cm)	Azimuth (deg.)	P/F	Remark
1	2878.500	58.66	-14.62	44.04	74.00	29.96	peak	150	10	P	
2	4817.000	47.76	-8.07	39.69	54.00	14.31	AVG	150	0	P	
3	4822.875	63.22	-8.05	55.17	74.00	18.83	peak	150	308	P	
4	7058.375	48.72	-3.81	44.91	74.00	29.09	peak	150	304	P	
5	9523.375	47.70	0.32	48.02	74.00	25.98	peak	150	358	P	
6	13707.500	49.33	3.88	53.21	74.00	20.79	peak	150	247	P	
7	16117.250	48.45	5.00	53.45	74.00	20.55	peak	150	322	P	

REMARKS:

- 18GHz-26GHz not recorded for no spurious point have a margin of less than 6 dB with respect to the limits.
- PK detector measurement value is lower than the average limit. Therefore, there is no need to test AV detector measurements.

**Results of Band Edges Test (Radiated)**

Note: 802.11b/802.11g/802.11n (H20) /802.11n (H40) all have been tested, only worse case 802.11b is reported

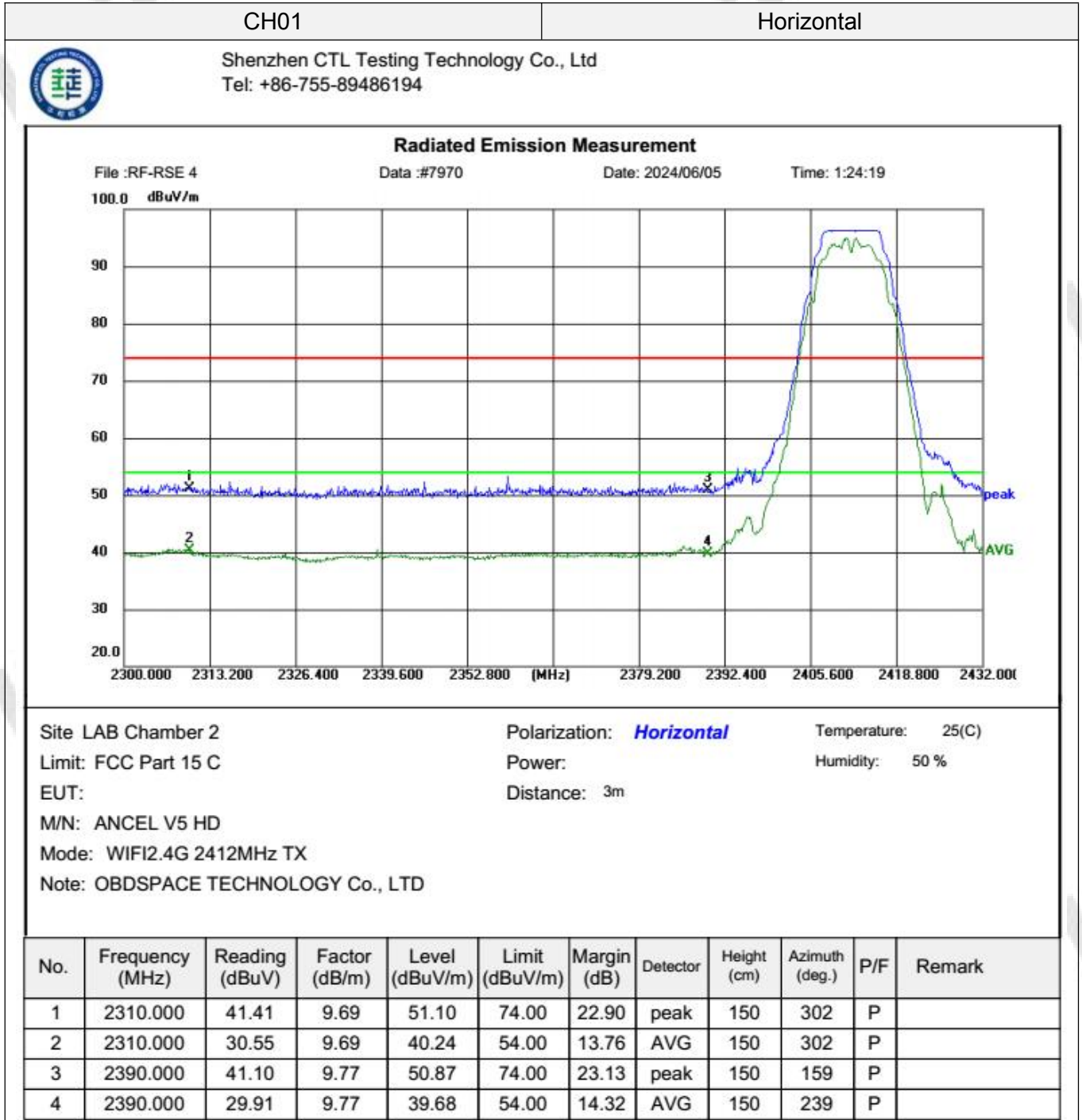

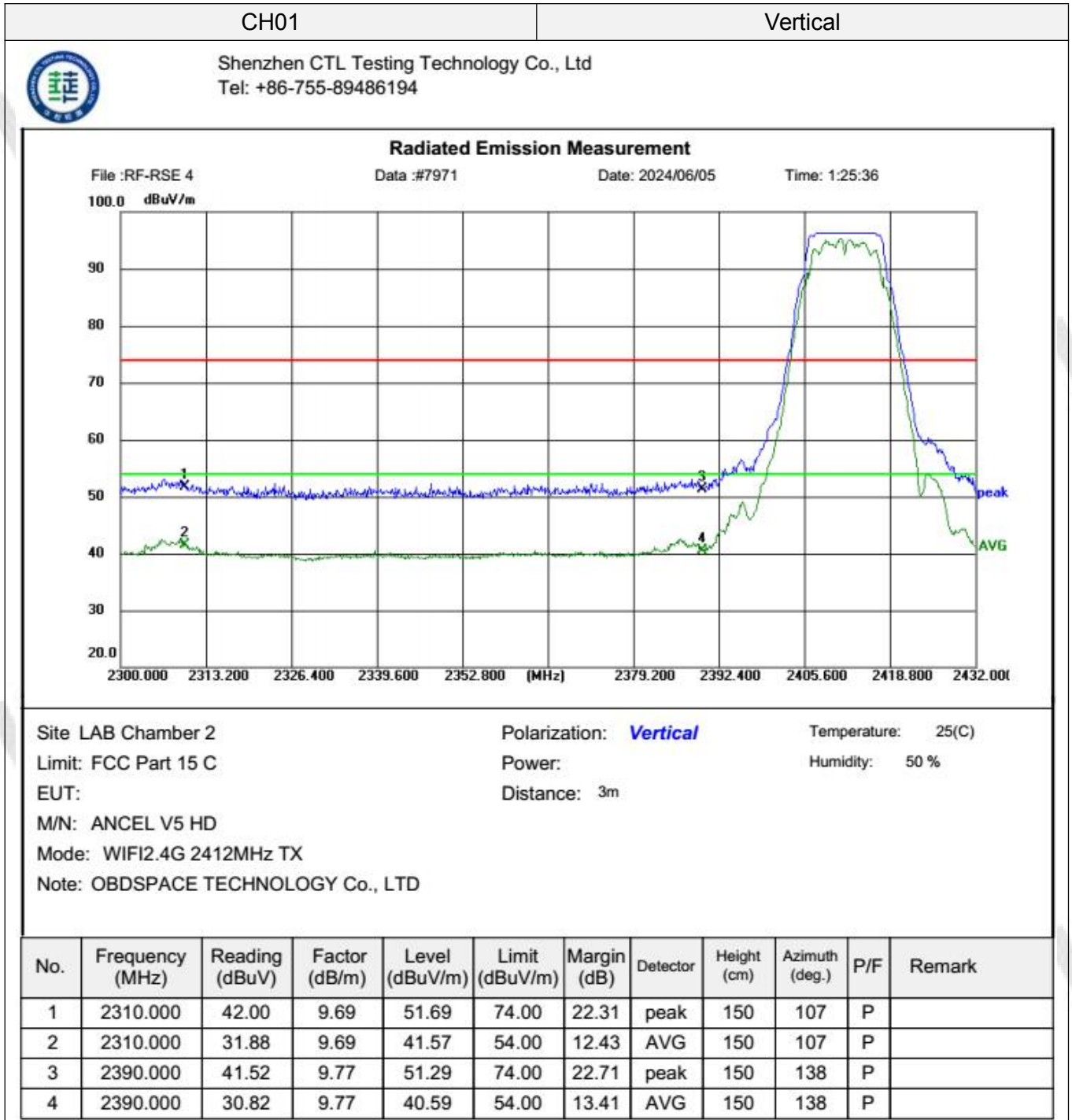

CH11

Horizontal



Shenzhen CTL Testing Technology Co., Ltd  
Tel: +86-755-89486194

**Radiated Emission Measurement**

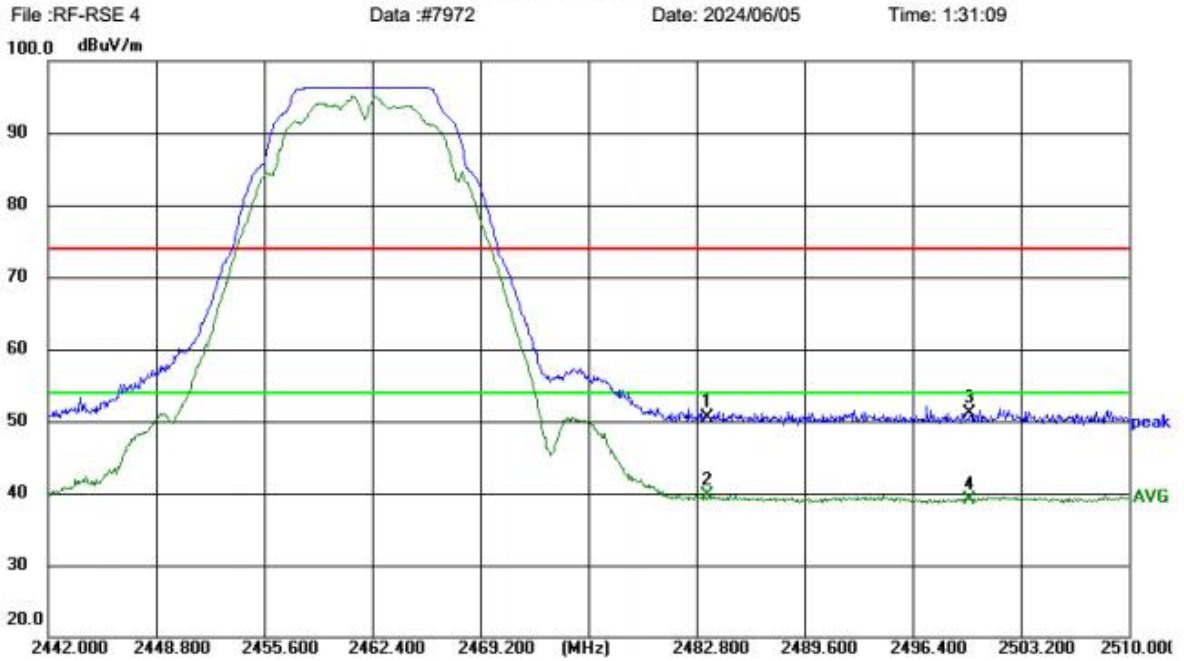

Site LAB Chamber 2  
Limit: FCC Part 15 C  
EUT:  
M/N: ANCEL V5 HD  
Mode: WIFI2.4G 2462MHz TX  
Note: OBDSpace TECHNOLOGY Co., LTD

Polarization: **Horizontal**      Temperature: 25(C)  
Power:      Humidity: 50 %  
Distance: 3m

No.	Frequency (MHz)	Reading (dBuV)	Factor (dB/m)	Level (dBuV/m)	Limit (dBuV/m)	Margin (dB)	Detector	Height (cm)	Azimuth (deg.)	P/F	Remark
1	2483.500	40.58	9.93	50.51	74.00	23.49	peak	150	138	P	
2	2483.500	29.71	9.93	39.64	54.00	14.36	AVG	150	138	P	
3	2500.000	41.10	10.00	51.10	74.00	22.90	peak	150	354	P	
4	2500.000	29.11	10.00	39.11	54.00	14.89	AVG	150	34	P	

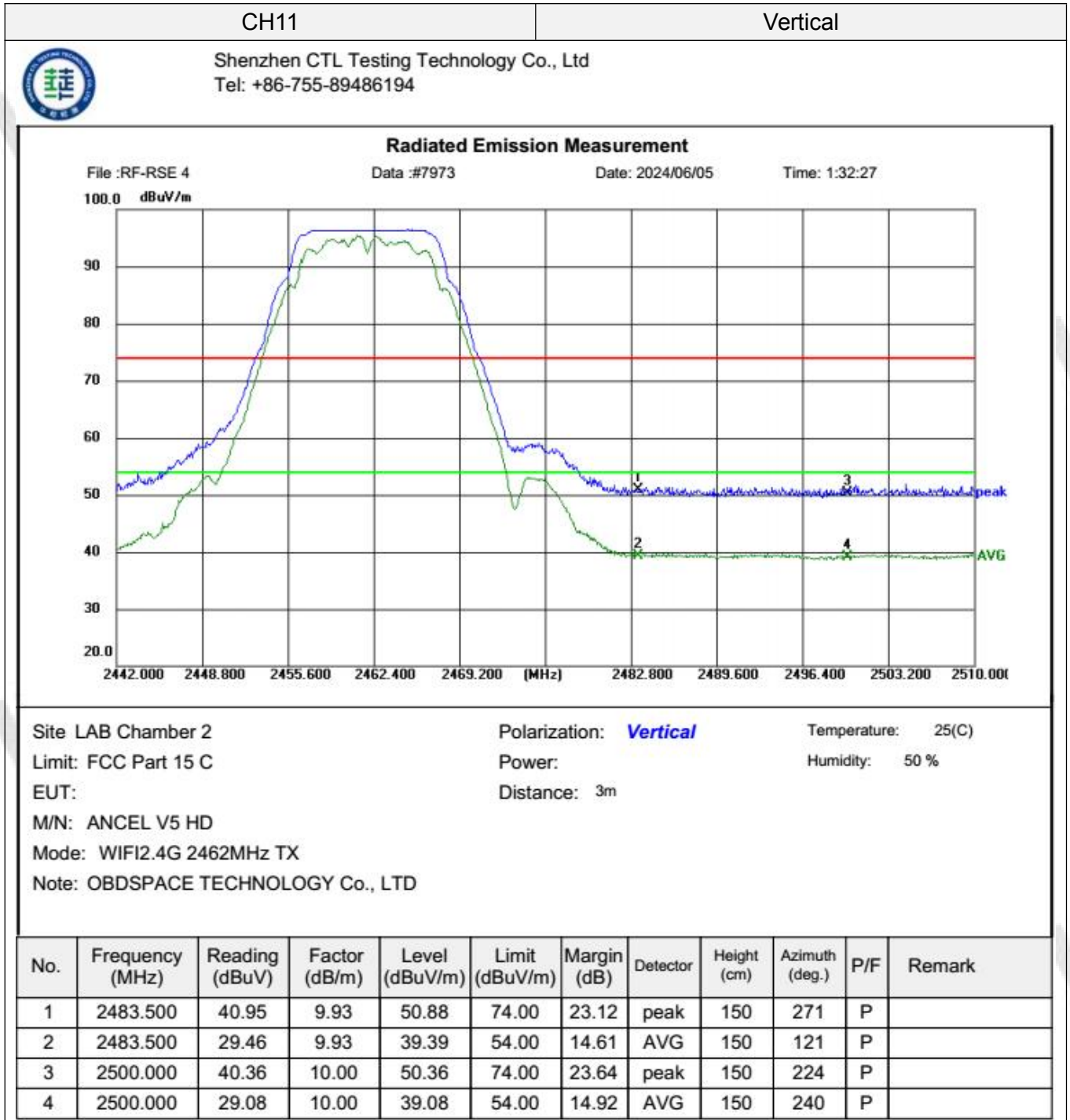



### 3.3. Maximum Conducted Output Power

#### Limit

The Maximum Peak Output Power Measurement is 30dBm.

#### Test Procedure

Remove the antenna from the EUT and then connect a low loss RF cable from the antenna port to the spectrum.

#### Test Configuration

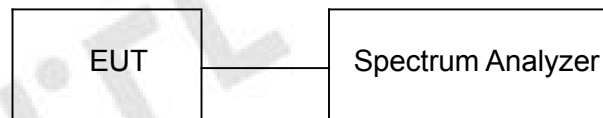

#### Test Results

Raw data reference to Section 2 of document No. CTL2404222135-WF03\_2.4GWIFI\_Appendix.

### 3.4. Power Spectral Density

#### Limit

For digitally modulated systems, the power spectral density conducted from the intentional radiator to the antenna shall not be greater than 8 dBm in any 3 kHz band during any time interval of continuous transmission.

#### Test Procedure

1. Use this procedure when the maximum conducted output power in the fundamental emission is used to demonstrate compliance.
2. Set the RBW  $\geq$  3 kHz.
3. Set the VBW  $\geq$  3 $\times$  RBW.
4. Set the span to 1.5 times the DTS channel bandwidth.
5. Detector = Average.
6. Trace mode = max hold.
7. Allow trace to fully stabilize.
8. Use the peak marker function to determine the maximum power level.
9. If measured value exceeds limit, reduce RBW (no less than 3 kHz) and repeat.
10. The resulting PSD level must be 8dBm.

#### Test Configuration



#### Test Results

Raw data reference to Section 3 of document No. CTL2404222135-WF03\_2.4GWIFI\_Appendix.

### 3.5. 6dB Bandwidth

#### Limit

For digital modulation systems, the minimum 6 dB bandwidth shall be at least 500 kHz

#### Test Procedure

The transmitter output was connected to the spectrum analyzer through an attenuator. The bandwidth of the fundamental frequency was measured by spectrum analyzer with 100 KHz RBW and 300 KHz VBW. The 6dB bandwidth is defined as the total spectrum the power of which is higher than peak power minus 6dB.

#### Test Configuration



#### Test Results

Raw data reference to Section 1 of document No. CTL2404222135-WF03\_2.4GWIFI\_Appendix.

### 3.6. Out-of-band Emissions

#### Limit

In any 100 kHz bandwidth outside the frequency band in which the spread spectrum or digitally modulated intentional radiator is operating, the radio frequency power that is produced by the intentional radiator shall be at least 20 dB below that in the 100 kHz bandwidth within the band that contains the highest level of the desired power, based on either an RF conducted or a radiated measurement, provided the transmitter demonstrates compliance with the peak conducted power limits. If the transmitter complies with the conducted power limits based on the use of RMS averaging over a time interval, as permitted under paragraph (b)(3) of this section, the attenuation required under this paragraph shall be 30 dB instead of 20 dB. Attenuation below the general limits specified in §15.209(a) is not required.

#### Test Procedure

Connect the transmitter output to spectrum analyzer using a low loss RF cable, and set the spectrum analyzer to RBW=100 kHz, VBW= 300 kHz, peak detector , and max hold. Measurements utilizing these setting are made of the in-band reference level, bandedge and out-of-band emissions.

#### Test Configuration



#### Test Results

Raw data reference to Section 4 of document No. CTL2404222135-WF03\_2.4GWIFI\_Appendix.

### 3.7. Antenna Requirement

#### Standard Applicable

**For intentional device, according to FCC 47 CFR Section 15.203:**

An intentional radiator shall be designed to ensure that no antenna other than that furnished by the responsible party shall be used with the device. The use of a permanently attached antenna or of an antenna that uses a unique coupling to the intentional radiator, the manufacturer may design the unit so that a broken antenna can be replaced by the user, but the use of a standard antenna jack or electrical connector is prohibited

#### **FCC CFR Title 47 Part 15 Subpart C Section 15.247(b) (4):**

(4) The conducted output power limit specified in paragraph (b) of this section is based on the use of antennas with directional gains that do not exceed 6 dBi. Except as shown in paragraph (c) of this section, if transmitting antennas of directional gain greater than 6 dBi are used, the conducted output power from the intentional radiator shall be reduced below the stated values in paragraphs (b)(1), (b)(2), and (b)(3) of this section, as appropriate, by the amount in dB that the directional gain of the antenna exceeds 6 dBi.

#### **Test Result:**

The maximum gain of antenna was 1.89dBi.

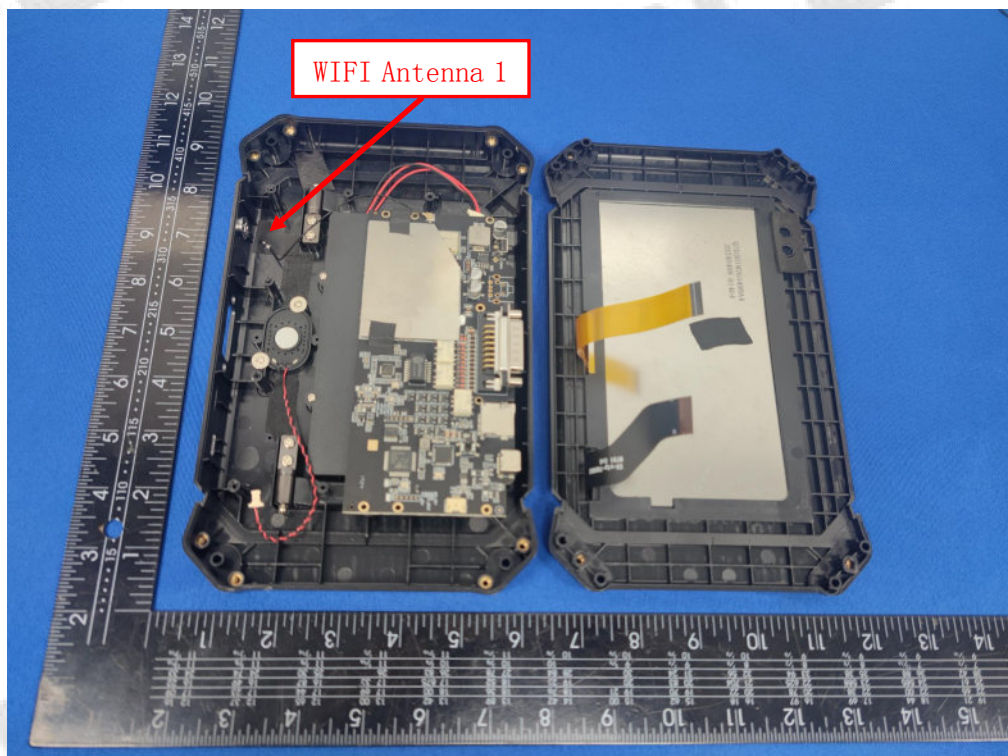

#### 4. Test Setup Photos of the EUT

Reference to the test report No. CTL2404222135-WF01.

#### 5. Photos of the EUT

Reference to the test report No. CTL2404222135-WF01.

\*\*\*\*\* End of Report \*\*\*\*\*