



# FCC TEST REPORT

**Test report**  
**On Behalf of**  
**Hangzhou Xizhi Electronics Co., Ltd.**  
**For**  
**Infrared remote controller**  
**Model No.: UFO-R1,UFO-R2,UFO-R1(B),UFO-R2(B)**

**FCC ID:2ASBR-UFO-R1**

**Prepared for :** Hangzhou Xizhi Electronics Co., Ltd.  
The second floor,Building 3, No. 8 Yuyang Road, Lushan Subdistrict, Fuyang,  
Hangzhou, Zhejiang,China

**Prepared By :** Shenzhen HUAKE Testing Technology Co., Ltd.  
1F, B2 Building, Junfeng Zhongcheng Zhizao Innovation Park, Fuhai Street,  
Bao'an District, Shenzhen City, China



# TEST REPORT

**Applicant's name** ..... : Hangzhou Xizhi Electronics Co., Ltd.  
 Address ..... : The second floor,Building 3,No. 8 Yuyang Road, Lushan Subdistrict,Fuyang, Hangzhou, Zhejiang,China

**Manufacture's Name** ..... : Hangzhou Xizhi Electronics Co., Ltd.  
 Address ..... : The second floor,Building 3,No. 8 Yuyang Road, Lushan Subdistrict,Fuyang, Hangzhou, Zhejiang,China

### Product description

Trade Mark: /  
 Product name..... : Infrared remote controller  
 Model and/or type reference : UFO-R1,UFO-R2,UFO-R1(B),UFO-R2(B)  
**Standards** ..... : FCC Rules and Regulations Part 15 Subpart C Section 15.247  
 ANSI C63.10: 2013

This publication may be reproduced in whole or in part for non-commercial purposes as long as the Shenzhen HUAK Testing Technology Co., Ltd. is acknowledged as copyright owner and source of the material. Shenzhen HUAK Testing Technology Co., Ltd. takes no responsibility for and will not assume liability for damages resulting from the reader's interpretation of the reproduced material due to its placement and context.

**Date of Test**.....  
 Date (s) of performance of tests... Dec. 22, 2018 ~ Jan.08,2019  
 Date of Issue..... Jan.08,2019  
 Test Result..... **Pass**

Testing Engineer : Gary Qian  
 (Gary Qian)

Technical Manager : Eden Hu  
 (Eden Hu)

Authorized Signatory : Jason Zhou  
 (Jason Zhou)



**Table of Contents**

**Page**

**SUMMARY ..... 4**

1.1. TEST STANDARDS ..... 4

1.2. TEST DESCRIPTION ..... 4

1.3. TEST FACILITY ..... 5

1.4. STATEMENT OF THE MEASUREMENT UNCERTAINTY ..... 5

**2. GENERAL INFORMATION ..... 6**

2.1. ENVIRONMENTAL CONDITIONS ..... 6

2.2. GENERAL DESCRIPTION OF EUT ..... 6

2.3. DESCRIPTION OF TEST MODES AND TEST FREQUENCY ..... 6

2.4. EQUIPMENTS USED DURING THE TEST ..... 7

2.5. SPECIAL ACCESSORIES ..... 8

2.6. RELATED SUBMITTAL(S) / GRANT (S) ..... 8

2.7. MODIFICATIONS ..... 8

**3. TEST CONDITIONS AND RESULTS ..... 9**

3.1. CONDUCTED EMISSIONS TEST ..... 9

3.2. RADIATED EMISSIONS AND BAND EDGE ..... 12

3.3. MAXIMUM CONDUCTED OUTPUT POWER ..... 19

3.4. POWER SPECTRAL DENSITY ..... 20

3.5. 6DB BANDWIDTH ..... 23

3.6. OUT-OF-BAND EMISSIONS ..... 26

3.7. ANTENNA REQUIREMENT ..... 34

**4. TEST SETUP PHOTOS OF THE EUT ..... 35**



## SUMMARY

### 1.1. TEST STANDARDS

The tests were performed according to following standards:

[FCC Rules Part 15.247](#): Frequency Hopping, Direct Spread Spectrum and Hybrid Systems that are in operation within the bands of 902-928 MHz, 2400-2483.5 MHz, and 5725-5850 MHz

[ANSI C63.10: 2013](#): American National Standard for Testing Unlicensed Wireless Devices

[ANSI C63.4: 2014](#): –American National Standard for Methods of Measurement of Radio-Noise Emissions from Low-Voltage Electrical and Electronic Equipment in the Range of 9 kHz to 40GHz  
Range of 9 kHz to 40GHz

[KDB558074 D01 V05](#): Guidance for Performing Compliance Measurements on Digital Transmission Systems (DTS) Operating Under §15.247

### 1.2. Test Description

FCC PART 15.247		
FCC Part 15.207	AC Power Conducted Emission	PASS
FCC Part 15.247(a)(2)	6dB Bandwidth	PASS
FCC Part 15.247(d)	Spurious RF Conducted Emission	PASS
FCC Part 15.247(b)	Maximum Conducted Output Power	PASS
FCC Part 15.247(e)	Power Spectral Density	PASS
FCC Part 15.109/ 15.205/ 15.209	Radiated Emissions	PASS
FCC Part 15.247(d)	Band Edge	PASS
FCC Part 15.203/15.247 (b)	Antenna Requirement	PASS



## 1.3. Test Facility

### 1.3.1 Address of the test laboratory

Shenzhen HUAKE Testing Technology Co., Ltd.

1F, B2 Building, Junfeng Zhongcheng Zhizao Innovation Park, Fuhai Street, Bao'an District, Shenzhen City, China

The 3m-Semi anechoic test site fulfils CISPR 16-1-4 according to ANSI C63.4:2014 and CISPR 16-1-4:2010 SVSWR requirement for radiated emission above 1GHz.

## 1.4. Statement of the measurement uncertainty

The data and results referenced in this document are true and accurate. The reader is cautioned that there may be errors within the calibration limits of the equipment and facilities. The measurement uncertainty was calculated for all measurements listed in this test report acc. to CISPR 16 - 4 "Specification for radio disturbance and immunity measuring apparatus and methods – Part 4: Uncertainty in EMC Measurements" and is documented in the Shenzhen HUAKE Testing Technology Co., Ltd. quality system acc. to DIN EN ISO/IEC 17025. Furthermore, component and process variability of devices similar to that tested may result in additional deviation. The manufacturer has the sole responsibility of continued compliance of the device.

### Measurement Uncertainty

Conducted Emission Expanded Uncertainty	=	2.23dB, k=2
Radiated emission expanded uncertainty(9kHz-30MHz)	=	3.08dB, k=2
Radiated emission expanded uncertainty(30MHz-1000MHz)	=	4.42dB, k=2
Radiated emission expanded uncertainty(Above 1GHz)	=	4.06dB, k=2



## 2. GENERAL INFORMATION

### 2.1. Environmental conditions

During the measurement the environmental conditions were within the listed ranges:

Normal Temperature:	25°C
Relative Humidity:	55 %
Air Pressure:	101 kPa

### 2.2. General Description of EUT

Product Name:	Infrared remote controller
Model/Type reference:	UFO-R1,UFO-R2,UFO-R1(B),UFO-R2(B)
	There are two different types of structure and external appearance with same PCB board, test is performed on one structure and the results is representative for all structures.
Power supply:	DC 5V From External Adapter
<b>WIFI :</b>	
Supported type:	802.11b/802.11g/802.11n(H20)
Modulation:	802.11b: DSSS 802.11g/802.11n(H20): OFDM
Operation frequency:	802.11b/802.11g/802.11n(H20): 2412MHz~2462MHz
Channel number:	802.11b/802.11g/802.11n(H20): 11
Channel separation:	5MHz
Antenna type:	FPC antenna
Antenna gain:	3.23dBi

Note: For more details, please refer to the user's manual of the EUT.

### 2.3. Description of Test Modes and Test Frequency

The Applicant provides Engineering Commands to control the EUT staying in continuous transmitting (Duty Cycle more than 98%) and receiving mode for testing.

There are 11 channels provided to the EUT and Channel 01/06/11 were selected for WIFI test.

#### Operation Frequency WIFI :

Channel	Frequency(MHz)	Channel	Frequency(MHz)
<b>1</b>	<b>2412</b>	8	2447
2	2417	9	2452
3	2422	10	2457
4	2427	<b>11</b>	<b>2462</b>
5	2432		
<b>6</b>	<b>2437</b>		
7	2442		

Note: The line display in grey were the channel selected for testing

**Data Rate Used:**

Preliminary tests were performed in different data rate to find the worst radiated emission. The data rate shown in the table below is the worst-case rate with respect to the specific test item. Investigation has been done on all the possible configurations for searching the worst cases. The following table is a list of the test modes shown in this test report.

Test Items	Mode	Data Rate	Channel
Maximum Conducted Output Power Power Spectral Density 6dB Bandwidth Spurious RF conducted emission Radiated Emission 9kHz~1GHz& Radiated Emission 1GHz~10th Harmonic	11b/DSSS	1 Mbps	1/6/11
	11g/OFDM	6 Mbps	1/6/11
	11n(20MHz)/OFDM	6.5Mbps	1/6/11
Band Edge	11b/DSSS	1 Mbps	1/11
	11g/OFDM	6 Mbps	1/11
	11n(20MHz)/OFDM	6.5Mbps	1/11

**2.4. Equipments Used during the Test**

Item	Equipment	Manufacturer	Model No.	Serial No.	Last Cal.	Cal. Interval
1.	L.I.S.N. Artificial Mains Network	R&S	ENV216	HKE-002	Dec. 28, 2018	1 Year
2.	Receiver	R&S	ESCI 7	HKE-010	Dec. 28, 2018	1 Year
3.	RF automatic control unit	Tonscend	JS0806-2	HKE-060	Dec. 28, 2018	1 Year
4.	Spectrum analyzer	R&S	FSP40	HKE-025	Dec. 28, 2018	1 Year
5.	Spectrum analyzer	Agilent	N9020A	HKE-048	Dec. 28, 2018	1 Year
6.	Preamplifier	Schwarzbeck	BBV 9743	HKE-006	Dec. 28, 2018	1 Year
7.	EMI Test Receiver	Rohde & Schwarz	ESCI 7	HKE-010	Dec. 28, 2018	1 Year
8.	Bilog Broadband Antenna	Schwarzbeck	VULB9163	HKE-012	Dec. 28, 2018	1 Year
9.	Loop Antenna	Schwarzbeck	FMZB 1519 B	HKE-014	Dec. 28, 2018	1 Year
10.	Horn Antenna	Schwarzbeck	9120D	HKE-013	Dec. 28, 2018	1 Year
11.	Broadband Horn Antenna	SCHWARZBECK	BBHA 9170	HKE-017	Dec. 28, 2018	1 Year
12.	Pre-amplifier	EMCI	EMC051845SE	HKE-015	Dec. 28, 2018	1 Year
13.	Pre-amplifier	Agilent	83051A	HKE-016	Dec. 28, 2018	1 Year
14.	EMI Test Software EZ-EMC	Tonscend	JS1120-B Version	HKE-083	Dec. 28, 2018	N/A
15.	Power Sensor	Agilent	E9300A	HKE-086	Dec. 28, 2018	1 Year
16.	Spectrum analyzer	Agilent	N9020A	HKE-048	Dec. 28, 2018	1 Year
17.	Signal generator	Agilent	N5182A	HKE-029	Dec. 28, 2018	1 Year
18.	Signal Generator	Agilent	83630A	HKE-028	Dec. 28, 2018	1 Year
19.	Shielded room	Shiel Hong	4*3*3	HKE-039	Dec. 28, 2018	3 Year
20.	RF Cable(below 1GHz)	HUBER+SUHNER	RG214	HKE-055	Dec. 28, 2018	1 Year



21.	RF Cable(above 1GHz)	HUBER+SUHNER	RG214	HKE-056	Dec. 28, 2018	1 Year
-----	----------------------	--------------	-------	---------	---------------	--------

The calibration interval was one year

## 2.5. Special Accessories

Manufacturer	Description	Model	Serial Number	Certificate
Samsung	Adapter	EP-TA20CBC	/	/
/	/	/	/	/

## 2.6. Related Submittal(s) / Grant (s)

This submittal(s) (test report) is intended to comply with Section 15.247 of the FCC Part 15, Subpart C Rules.

## 2.7. Modifications

No modifications were implemented to meet testing criteria.



### 3. TEST CONDITIONS AND RESULTS

#### 3.1. Conducted Emissions Test

##### LIMIT

FCC CFR Title 47 Part 15 Subpart C Section 15.207

Frequency range (MHz)	Limit (dBuV)	
	Quasi-peak	Average
0.15-0.5	66 to 56*	56 to 46*
0.5-5	56	46
5-30	60	50

\* Decreases with the logarithm of the frequency.

##### TEST CONFIGURATION

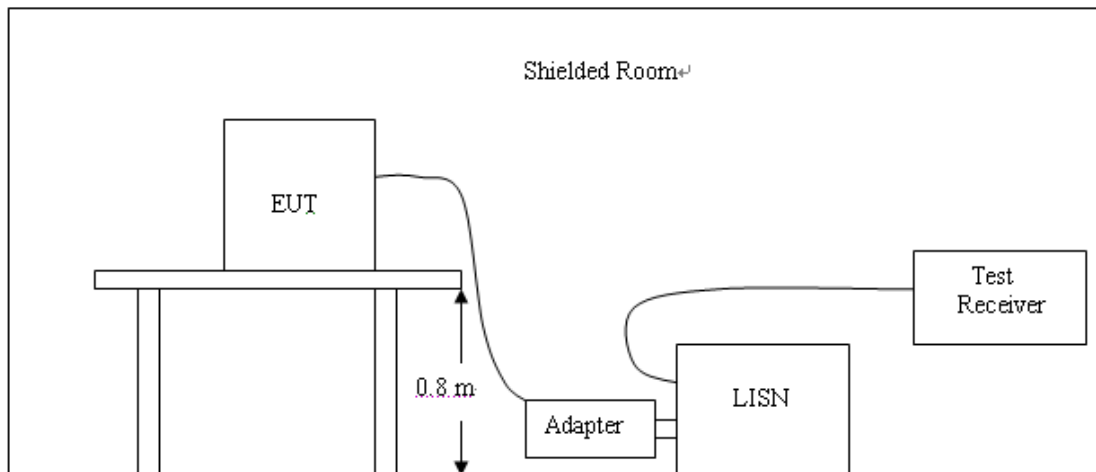

##### TEST PROCEDURE

1. The equipment was set up as per the test configuration to simulate typical actual usage per the user's manual. The EUT is a tabletop system; a wooden table with a height of 0.8 meters is used and is placed on the ground plane as per ANSI C63.10:2013.
2. Support equipment, if needed, was placed as per ANSI C63.10:2013.
3. All I/O cables were positioned to simulate typical actual usage as per ANSI C63.10:2013.
4. The adapter received AC power through a Line Impedance Stabilization Network (LISN) which supplied power source and was grounded to the ground plane.
5. All support equipments received AC power from a second LISN, if any.
6. The EUT test program was started. Emissions were measured on each current carrying line of the EUT using a spectrum Analyzer / Receiver connected to the LISN powering the EUT. The LISN has two monitoring points: Line 1 (Hot Side) and Line 2 (Neutral Side). Two scans were taken: one with Line 1 connected to Analyzer / Receiver and Line 2 connected to a 50 ohm load; the second scan had Line 1 connected to a 50 ohm load and Line 2 connected to the Analyzer / Receiver.
7. Analyzer / Receiver scanned from 150 KHz to 30MHz for emissions in each of the test modes.
8. During the above scans, the emissions were maximized by cable manipulation.



**TEST RESULTS**

Remark:

1. All modes of 802.11b/g/n were tested at Low, Middle, and High channel; only the worst result of 802.11b CH11 was reported as below:
2. Both 120 VAC, 50/60 Hz and 240 VAC, 50/60 Hz power supply have been tested, only the worst result of 120 VAC, 60 Hz was reported as below:
3. Pre-test AC conducted emission at power from AC mains mode and at charge from PC mode, recorded worst case.

Power supply:	DC 5V from Adapter 120V/60Hz	Polarization	L
---------------	---------------------------------	--------------	---

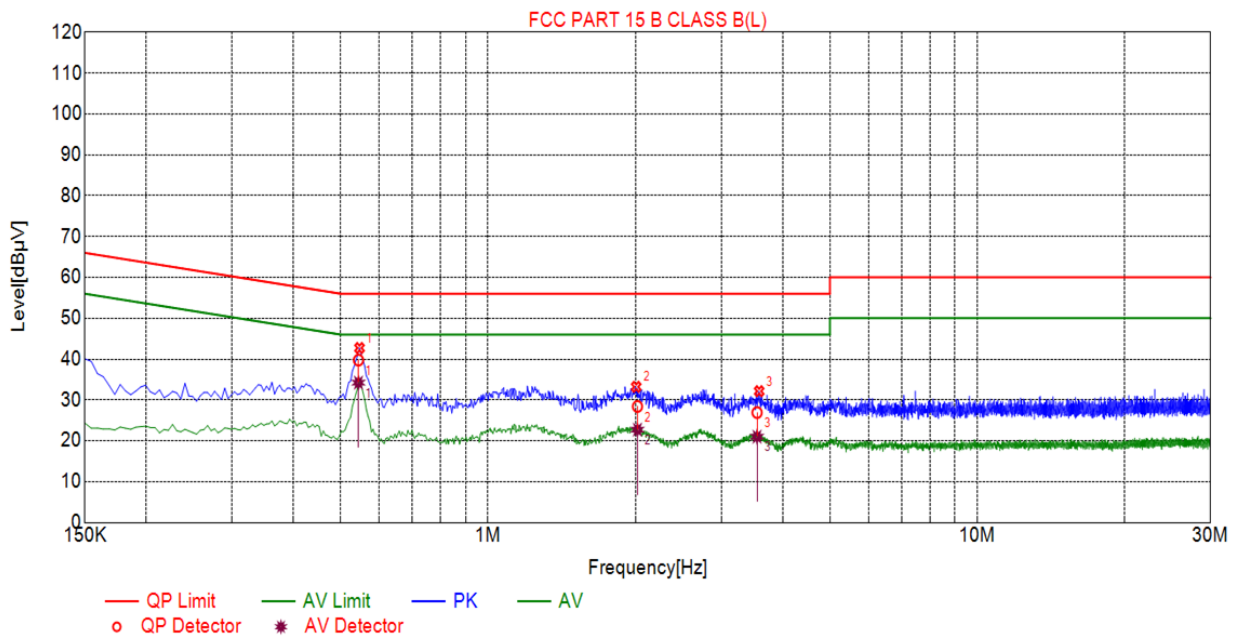

**Final Data List**

NO.	Freq. [MHz]	Factor [dB]	QP Value [dBµV]	QP Limit [dBµV]	QP Margin [dB]	AV Value [dBµV]	AV Limit [dBµV]	AV Margin [dB]
1	0.5433	10.05	39.77	56.00	16.23	34.24	46.00	11.76
2	2.0204	10.15	28.42	56.00	27.58	22.73	46.00	23.27
3	3.5477	10.25	26.93	56.00	29.07	21.01	46.00	24.99



Power supply:	DC 5V from Adapter 120V/60Hz	Polarization	N
---------------	---------------------------------	--------------	---

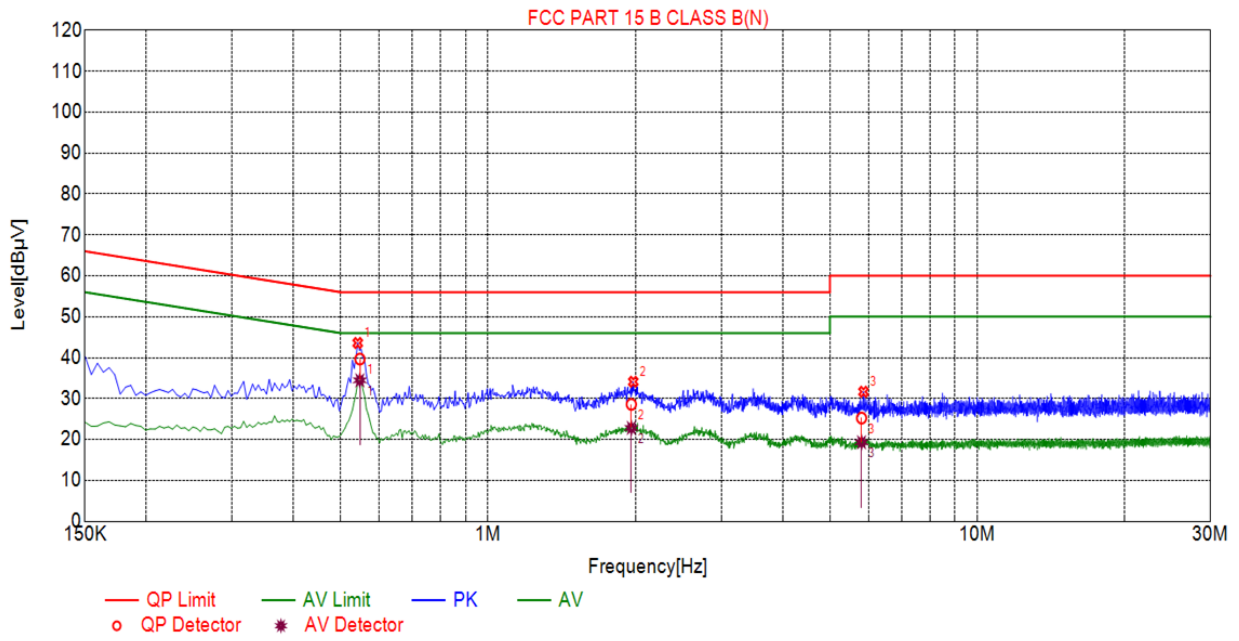

### Final Data List

NO.	Freq. [MHz]	Factor [dB]	QP Value [dBµV]	QP Limit [dBµV]	QP Margin [dB]	AV Value [dBµV]	AV Limit [dBµV]	AV Margin [dB]
1	0.5469	10.06	39.67	56.00	16.33	34.47	46.00	11.53
2	1.9629	10.14	28.59	56.00	27.41	22.83	46.00	23.17
3	5.8024	10.24	25.24	60.00	34.76	19.32	50.00	30.68

### 3.2. Radiated Emissions and Band Edge

#### Limit

For intentional device, according to § 15.209(a), the general requirement of field strength of radiated emission out of authorized band shall not exceed the following table at a 3 meters measurement distance.

In addition, radiated emissions which fall in the restricted bands, as defined in §15.205(a), must also comply with the radiated emission limits specified in §15.209(a)

Radiated emission limits

Frequency (MHz)	Distance (Meters)	Radiated (dBµV/m)	Radiated (µV/m)
0.009-0.49	3	$20\log(2400/F(\text{KHz}))+40\log(300/3)$	$2400/F(\text{KHz})$
0.49-1.705	3	$20\log(24000/F(\text{KHz}))+40\log(30/3)$	$24000/F(\text{KHz})$
1.705-30	3	$20\log(30)+40\log(30/3)$	30
30-88	3	40.0	100
88-216	3	43.5	150
216-960	3	46.0	200
Above 960	3	54.0	500

#### TEST CONFIGURATION

(A) Radiated Emission Test Set-Up, Frequency Below 30MHz

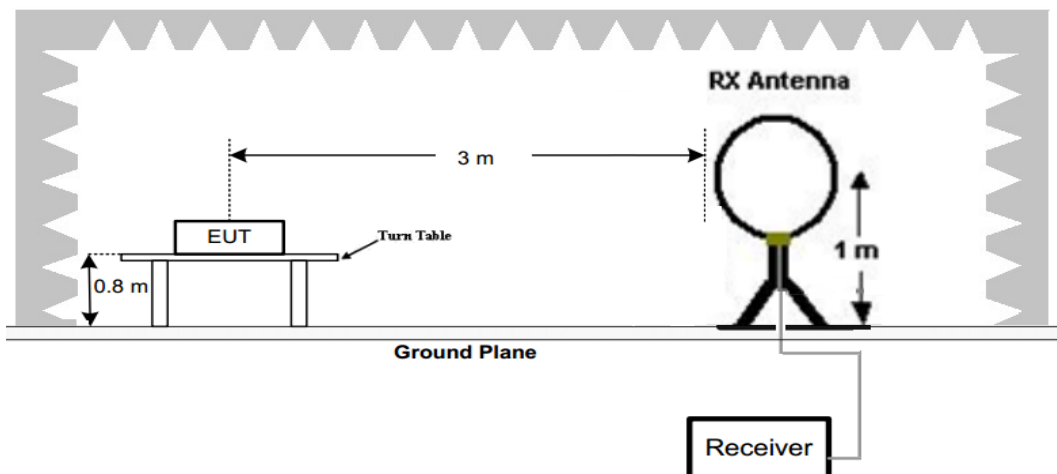

(B) Radiated Emission Test Set-Up, Frequency below 1000MHz

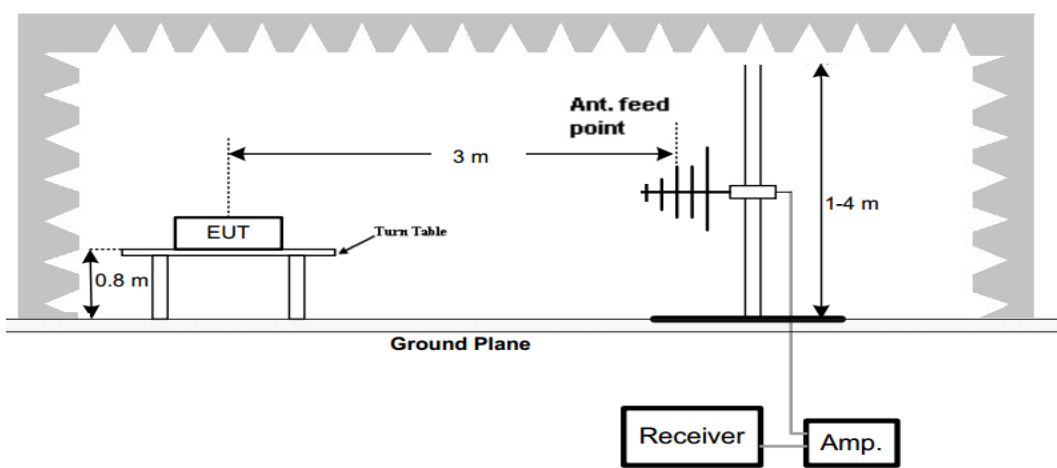

(C) Radiated Emission Test Set-Up, Frequency above 1000MHz

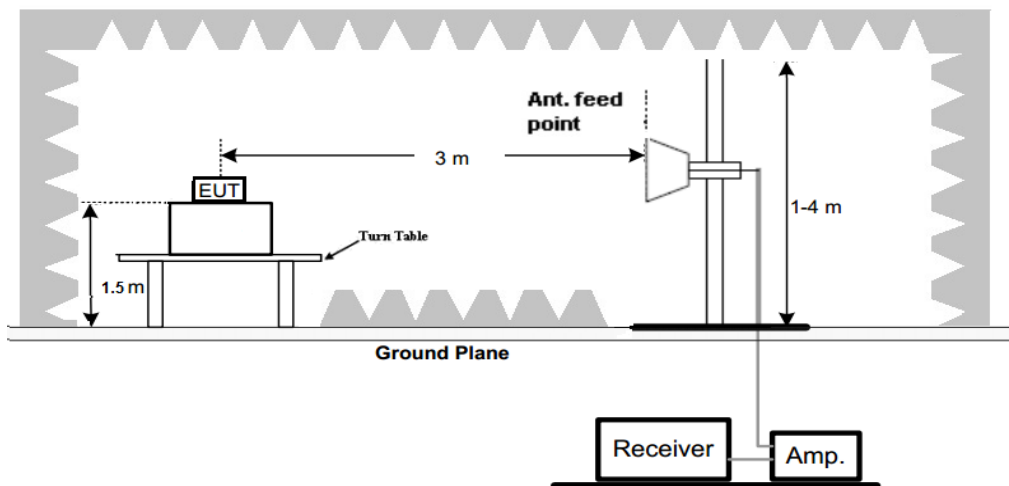

**Test Procedure**

1. Below 1GHz measurement the EUT is placed on a turntable which is 0.8m above ground plane, and above 1GHz measurement EUT was placed on a low permittivity and low loss tangent turn table which is 1.5m above ground plane.
2. Maximum procedure was performed by raising the receiving antenna from 1m to 4m and rotating the turn table from 0°C to 360°C to acquire the highest emissions from EUT
3. And also, each emission was to be maximized by changing the polarization of receiving antenna both horizontal and vertical.
4. Repeat above procedures until all frequency measurements have been completed.
5. Radiated emission test frequency band from 9KHz to 25GHz.
6. The distance between test antenna and EUT as following table states:

Test Frequency range	Test Antenna Type	Test Distance
9KHz-30MHz	Active Loop Antenna	3
30MHz-1GHz	Bilog Antenna	3
1GHz-18GHz	Horn Antenna	3
18GHz-25GHz	Horn Antenna	1

7. Setting test receiver/spectrum as following table states:

Test Frequency range	Test Receiver/Spectrum Setting	Detector
9KHz-150KHz	RBW=200Hz/VBW=3KHz, Sweep time=Auto	QP
150KHz-30MHz	RBW=9KHz/VBW=100KHz, Sweep time=Auto	QP
30MHz-1GHz	RBW=120KHz/VBW=1000KHz, Sweep time=Auto	QP
1GHz-40GHz	Peak Value: RBW=1MHz/VBW=3MHz, Sweep time=Auto Average Value: RBW=1MHz/VBW=10Hz, Sweep time=Auto	Peak

**TEST RESULTS**

Remark:

1. This test was performed with EUT in X, Y, Z position and the worse case was found when EUT in X position.
2. All three channels (lowest/middle/highest) of each mode were measured below 1GHz and recorded worst case at 802.11b low channel.
3. All three channels (lowest/middle/highest) of each mode were measured above 1GHz and recorded worst case at 802.11b mode.
4. Radiated emission test from 9 KHz to 10th harmonic of fundamental was verified, and no emission found except system noise floor in 9 KHz to 30MHz and not recorded in this report.



For 30MHz-1GHz

Horizontal

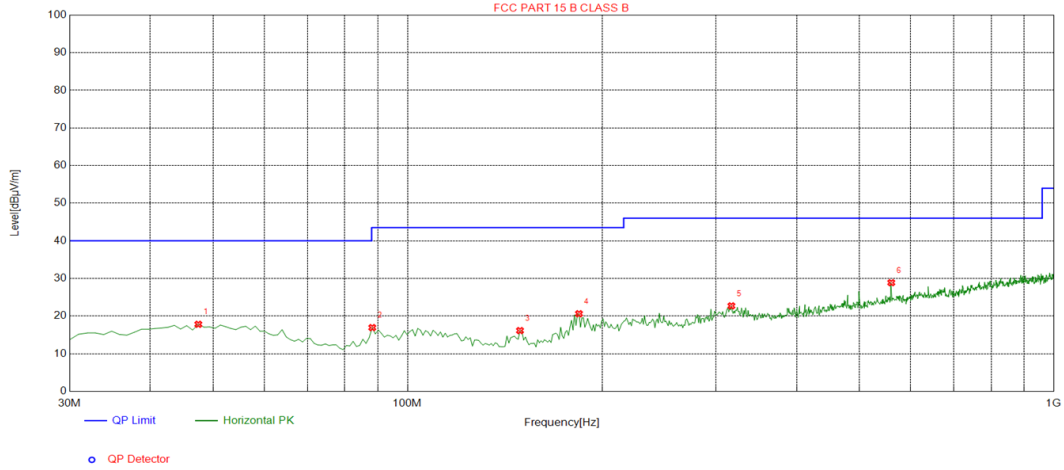

Suspected List

NO.	Freq. [MHz]	Level [dBµV/m]	Factor [dB]	Limit [dBµV/m]	Margin [dB]	Height [cm]	Angle [°]	Polarity
1	47.4600	17.81	-13.65	40.00	22.19	100	98	Horizontal
2	88.2000	16.93	-17.50	43.50	26.57	100	43	Horizontal
3	149.310	16.14	-18.96	43.50	27.36	100	247	Horizontal
4	184.230	20.62	-16.50	43.50	22.88	100	272	Horizontal
5	317.120	22.71	-12.25	46.00	23.29	100	255	Horizontal
6	560.590	28.88	-6.66	46.00	17.12	100	115	Horizontal

Vertical

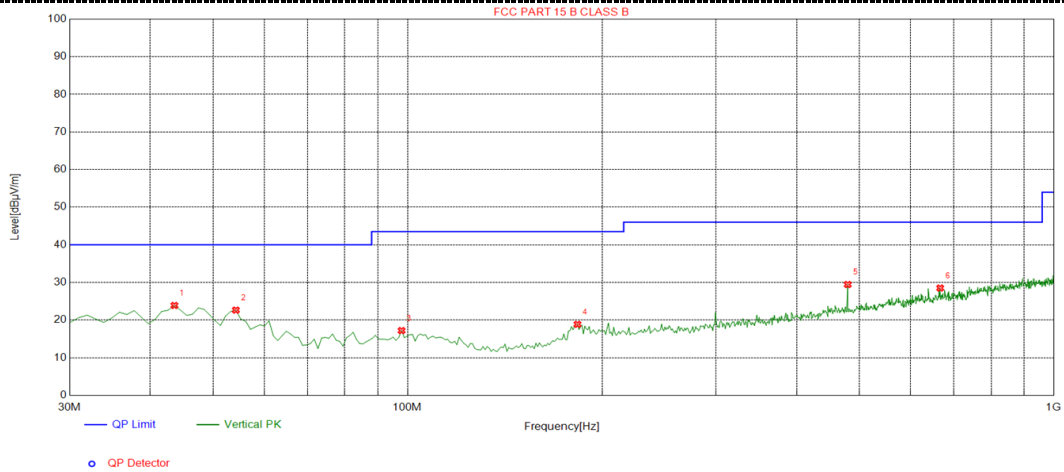

Suspected List

NO.	Freq. [MHz]	Level [dBµV/m]	Factor [dB]	Limit [dBµV/m]	Margin [dB]	Height [cm]	Angle [°]	Polarity
1	43.5800	23.88	-13.90	40.00	16.12	100	223	Vertical
2	54.2500	22.65	-14.29	40.00	17.35	100	201	Vertical
3	97.9000	17.20	-15.75	43.50	26.30	100	296	Vertical
4	183.260	18.87	-16.58	43.50	24.63	100	296	Vertical
5	480.080	29.45	-8.45	46.00	16.55	100	343	Vertical
6	667.290	28.51	-4.73	46.00	17.49	100	176	Vertical



**For 1GHz to 25GHz**

**802.11b Mode (above 1GHz)**

Note: 802.11b/802.11g/802.11n (H20) all have been tested, only worse case 802.11b is reported

Horizontal: LOW CH1 (802.11b Mode)/2412

Frequency	Meter Reading	Factor	Emission Level	Limits	Margin	Detector Type
(MHz)	(dBµV)	(dB)	(dBµV/m)	(dBµV/m)	(dB)	
4824	62.25	-3.64	58.61	74	-15.39	peak
4824	46.17	-3.64	42.53	54	-11.47	AVG
7236	56.06	-0.95	55.11	74	-18.89	peak
7236	42.16	-0.95	41.21	54	-12.79	AVG
---	---	---	---	---	---	---
---	---	---	---	---	---	---

Remark: Factor = Antenna Factor + Cable Loss – Pre-amplifier.

Vertical: LOW CH1 (802.11b Mode)/2412

Frequency	Meter Reading	Factor	Emission Level	Limits	Margin	Detector Type
(MHz)	(dBµV)	(dB)	(dBµV/m)	(dBµV/m)	(dB)	
4824	62.17	-3.64	58.53	74	-15.47	peak
4824	46.35	-3.64	42.71	54	-11.29	AVG
7236	58.46	-0.95	57.51	74	-16.49	peak
7236	42.22	-0.95	41.27	54	-12.73	AVG
---	---	---	---	---	---	---
---	---	---	---	---	---	---

Remark: Factor = Antenna Factor + Cable Loss – Pre-amplifier.



## Horizontal: MID CH6 (802.11b Mode)/2437

Frequency	Meter Reading	Factor	Emission Level	Limits	Margin	Detector Type
(MHz)	(dB $\mu$ V)	(dB)	(dB $\mu$ V/m)	(dB $\mu$ V/m)	(dB)	
4874	62.23	-3.51	58.72	74	-15.28	peak
4874	45.62	-3.51	42.11	54	-11.89	AVG
7311	58.37	-0.82	57.55	74	-16.45	peak
7311	42.45	-0.82	41.63	54	-12.37	AVG
---	---	---	---	---	---	---
---	---	---	---	---	---	---

Remark: Factor = Antenna Factor + Cable Loss – Pre-amplifier.

## Vertical: MID CH6 (802.11b Mode)/2437

Frequency	Meter Reading	Factor	Emission Level	Limits	Margin	Detector Type
(MHz)	(dB $\mu$ V)	(dB)	(dB $\mu$ V/m)	(dB $\mu$ V/m)	(dB)	
4874	61.46	-3.51	57.95	74	-16.05	peak
4874	45.59	-3.51	42.08	54	-11.92	AVG
7311	58.72	-0.82	57.9	74	-16.1	peak
7311	43.46	-0.82	42.64	54	-11.36	AVG
---	---	---	---	---	---	---
---	---	---	---	---	---	---

Remark: Factor = Antenna Factor + Cable Loss – Pre-amplifier.





## Horizontal: HIGH CH11 (802.11b Mode)/2462

Frequency (MHz)	Meter Reading (dB $\mu$ V)	Factor (dB)	Emission Level (dB $\mu$ V/m)	Limits (dB $\mu$ V/m)	Margin (dB)	Detector Type
4924	62.13	-3.43	58.7	74	-15.3	peak
4924	45.26	-3.43	41.83	54	-12.17	AVG
7386	57.75	-0.75	57	74	-17	peak
7386	43.38	-0.75	42.63	54	-11.37	AVG
---	---	---	---	---	---	---
---	---	---	---	---	---	---

Remark: Factor = Antenna Factor + Cable Loss – Pre-amplifier.

## Vertical: HIGH CH11 (802.11b Mode)/2462

Frequency (MHz)	Meter Reading (dB $\mu$ V)	Factor (dB)	Emission Level (dB $\mu$ V/m)	Limits (dB $\mu$ V/m)	Margin (dB)	Detector Type
4924	61.35	-3.43	57.92	74	-16.08	peak
4924	46.42	-3.43	42.99	54	-11.01	AVG
7386	59.39	-0.75	58.64	74	-15.36	peak
7386	43.28	-0.75	42.53	54	-11.47	AVG
---	---	---	---	---	---	---
---	---	---	---	---	---	---

Remark: Factor = Antenna Factor + Cable Loss – Pre-amplifier.

## Remark :

- (1) Data of measurement within this frequency range shown “---” in the table above means the reading of emissions are attenuated more than 20dB below the permissible limits or the field strength is too small to be measured.
- (2) When the test results of Peak Detected below the limits of Average Detected, the Average Detected is not need completed.

**Results of Band Edges Test (Radiated)**

Note: 802.11b/802.11g/802.11n (H20) all have been tested, only worse case 802.11b is reported

Horizontal: 802.11b Mode TX CH Low (2412MHz)

Frequency	Meter Reading	Factor	Emission Level	Limits	Margin	Detector Type
(MHz)	(dB $\mu$ V)	(dB)	(dB $\mu$ V/m)	(dB $\mu$ V/m)	(dB)	
2390	62.45	-5.81	56.64	74	-17.36	peak
2390	45.63	-5.81	39.82	54	-14.18	AVG
---	---	---	---	---	---	---
---	---	---	---	---	---	---

Remark: Factor = Antenna Factor + Cable Loss – Pre-amplifier.

Vertical: 802.11b Mode TX CH Low (2412MHz)

Frequency	Meter Reading	Factor	Emission Level	Limits	Margin	Detector Type
(MHz)	(dB $\mu$ V)	(dB)	(dB $\mu$ V/m)	(dB $\mu$ V/m)	(dB)	
2390	63.45	-5.81	57.64	74	-16.36	peak
2390	46.16	-5.81	40.35	54	-13.65	AVG
---	---	---	---	---	---	---
---	---	---	---	---	---	---

Remark: Factor = Antenna Factor + Cable Loss – Pre-amplifier.

Horizontal: 802.11b Mode TX CH HIGH (2462MHz)

Frequency	Meter Reading	Factor	Emission Level	Limits	Margin	Detector Type
(MHz)	(dB $\mu$ V)	(dB)	(dB $\mu$ V/m)	(dB $\mu$ V/m)	(dB)	
2483.5	60.16	-5.65	54.51	74	-19.49	peak
2483.5	43.27	-5.65	37.62	54	-16.38	AVG

Remark: Factor = Antenna Factor + Cable Loss – Pre-amplifier.

Vertical: 802.11b Mode TX CH HIGH (2462MHz)

Frequency	Meter Reading	Factor	Emission Level	Limits	Margin	Detector Type
(MHz)	(dB $\mu$ V)	(dB)	(dB $\mu$ V/m)	(dB $\mu$ V/m)	(dB)	
2483.5	62.46	-5.65	56.81	74	-17.19	peak
2483.5	44.75	-5.65	39.1	54	-14.9	AVG

Remark: Factor = Antenna Factor + Cable Loss – Pre-amplifier.

Remark: All the other emissions not reported were too low to read and deemed to comply with FCC limit.



### 3.3. Maximum Conducted Output Power

#### Limit

The Maximum Peak Output Power Measurement is 30dBm.

#### Test Procedure

Remove the antenna from the EUT and then connect a low loss RF cable from the antenna port to the power sensor.

#### Test Configuration

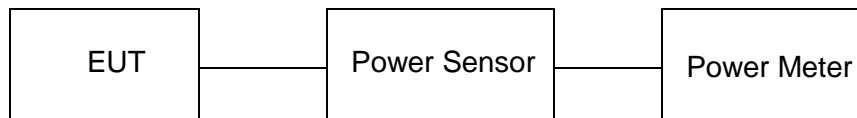

#### Test Results

WIFI				
Type	Channel	Output power PK (dBm)	Limit (dBm)	Result
802.11b	01	7.06	30.00	Pass
	06	8.05		
	11	8.18		
802.11g	01	8.08	30.00	Pass
	06	8.80		
	11	8.98		
802.11n(HT20)	01	7.87	30.00	Pass
	06	8.49		
	11	8.69		

Note:

- 1) Measured output power at difference data rate for each mode and recorded worst case for each mode.
- 2) Test results including cable loss;
- 3) Worst case data at 1Mbps at IEEE 802.11b; 6Mbps at IEEE 802.11g; 6.5Mbps at IEEE 802.11n HT20.



### 3.4. Power Spectral Density

#### Limit

For digitally modulated systems, the power spectral density conducted from the intentional radiator to the antenna shall not be greater than 8 dBm in any 3 kHz band during any time interval of continuous transmission.

#### Test Procedure

1. Use this procedure when the maximum peak conducted output power in the fundamental emission is used to demonstrate compliance.
2. Set the RBW  $\geq$  3 kHz.
3. Set the VBW  $\geq$  3 $\times$  RBW.
4. Set the span to 1.5 times the DTS channel bandwidth.
5. Detector = peak.
6. Sweep time = auto couple.
7. Trace mode = max hold.
8. Allow trace to fully stabilize.
9. Use the peak marker function to determine the maximum power level.
10. If measured value exceeds limit, reduce RBW (no less than 3 kHz) and repeat.
11. The resulting peak PSD level must be 8dBm.

#### Test Configuration

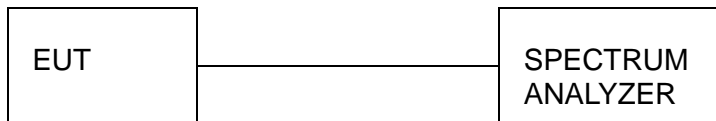

#### Test Results

WIFI				
Type	Channel	Power Spectral Density (dBm/30KHz)	Limit (dBm/3KHz)	Result
802.11b	01	-9.57	8.00	Pass
	06	-8.21		
	11	-8.06		
802.11g	01	-15.2	8.00	Pass
	06	-14.91		
	11	-15.4		
802.11n(HT20)	01	-15.88	8.00	Pass
	06	-15.55		
	11	-15.43		

Test plot as follows:

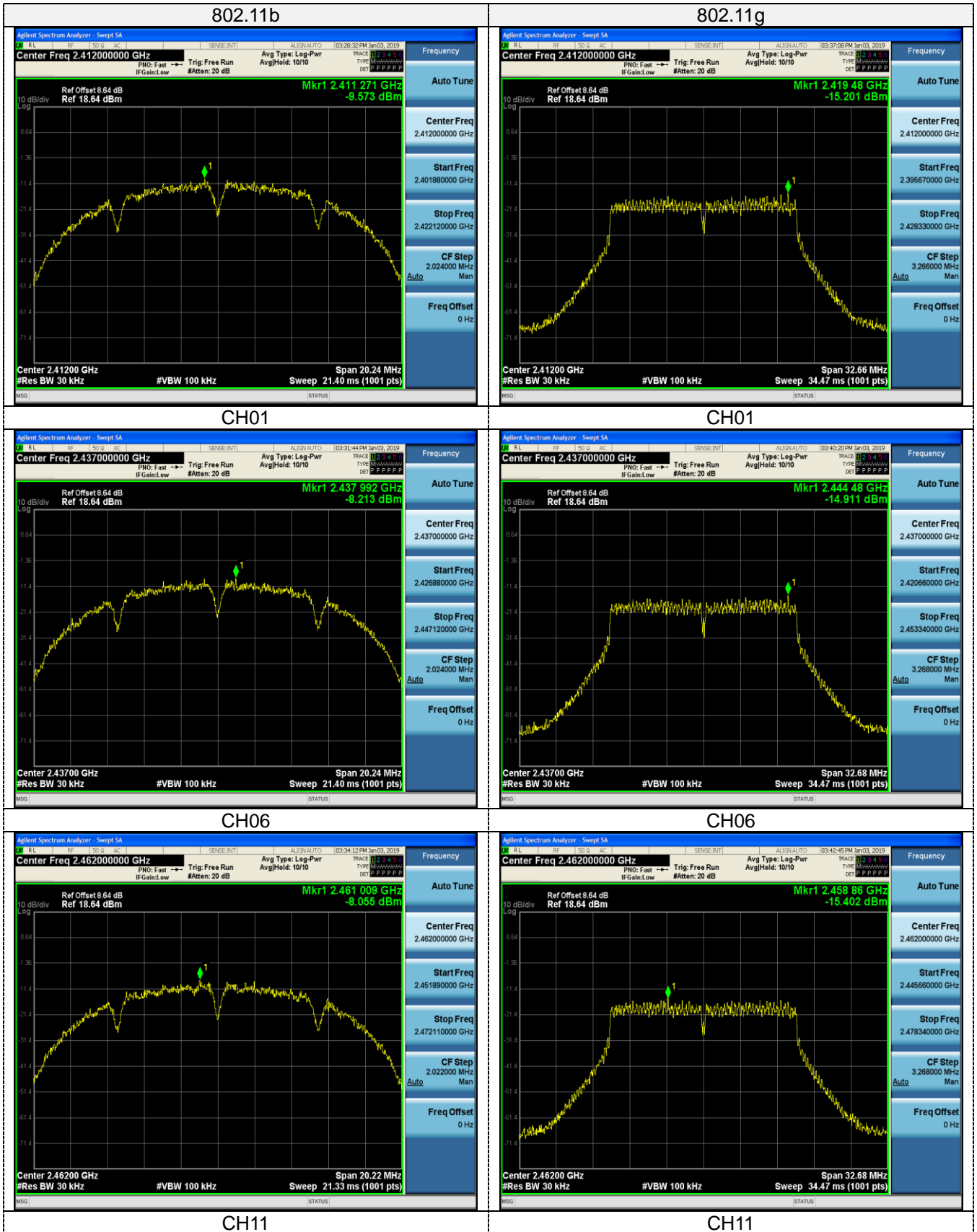



802.11n(HT20)

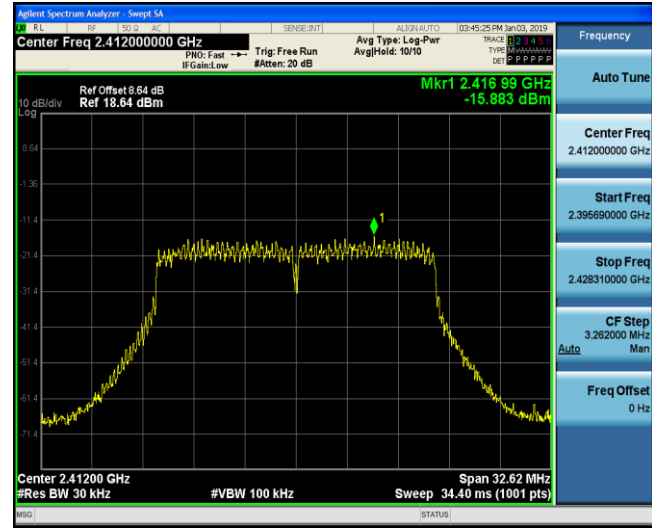

CH01

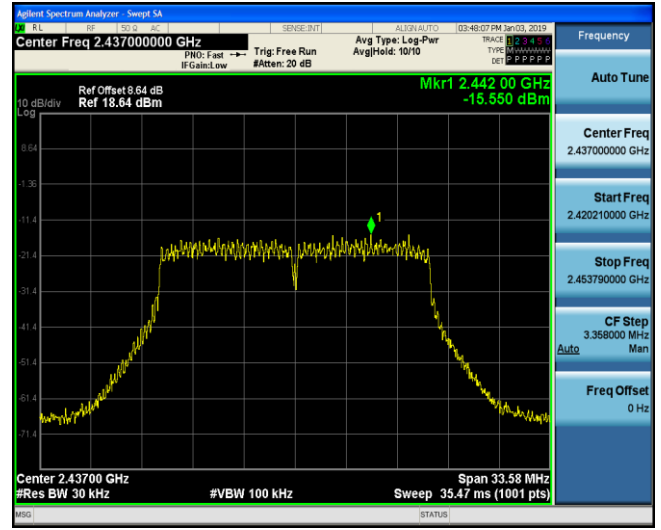

CH06

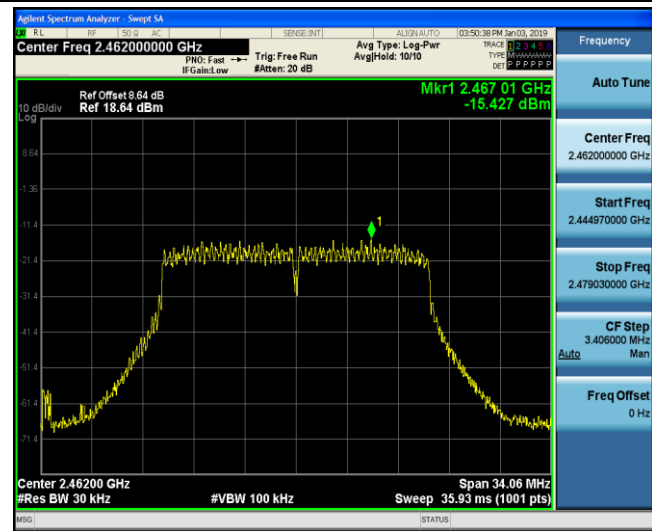

CH11



### 3.5. 6dB Bandwidth

#### Limit

For digital modulation systems, the minimum 6 dB bandwidth shall be at least 500 kHz

#### Test Procedure

The transmitter output was connected to the spectrum analyzer through an attenuator. The bandwidth of the fundamental frequency was measured by spectrum analyzer with 100 KHz RBW and 300 KHz VBW. The 6dB bandwidth is defined as the total spectrum the power of which is higher than peak power minus 6dB.

#### Test Configuration

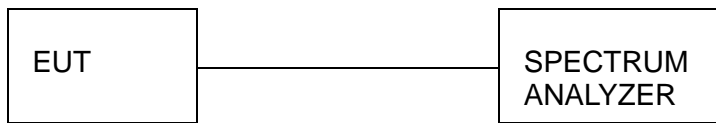

#### Test Results

##### *WIFI*

Type	Channel	6dB Bandwidth (MHz)	Limit (KHz)	Result
802.11b	01	10.12	≥500	Pass
	06	10.12		
	11	10.11		
802.11g	01	16.33	≥500	Pass
	06	16.34		
	11	16.34		
802.11n(HT20)	01	16.31	≥500	Pass
	06	16.79		
	11	17.03		

Note:

- 1) Measured peak power spectrum density at difference data rate for each mode and recorded worst case for each mode.
- 2) Test results including cable loss;
- 3) Worst case data at 1Mbps at IEEE 802.11b; 6Mbps at IEEE 802.11g; 6.5Mbps at IEEE 802.11n HT20.
- 4) Please refer to following plots;



802.11b



802.11g

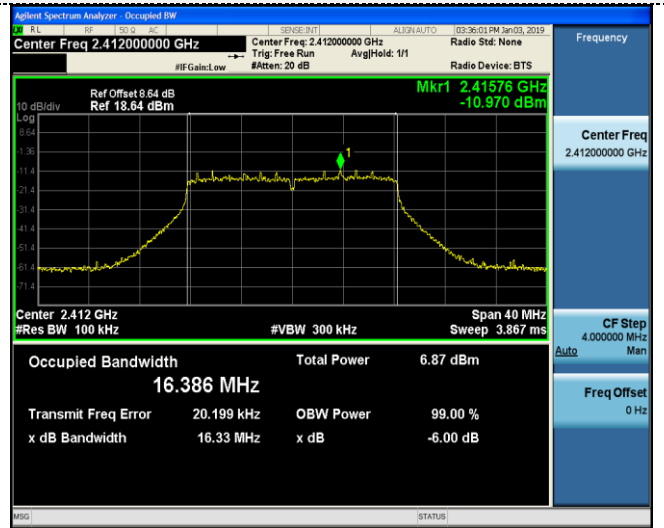

CH01

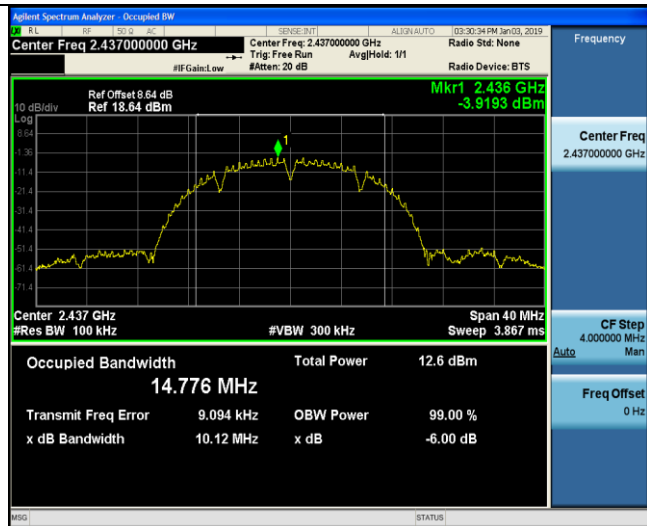

CH01

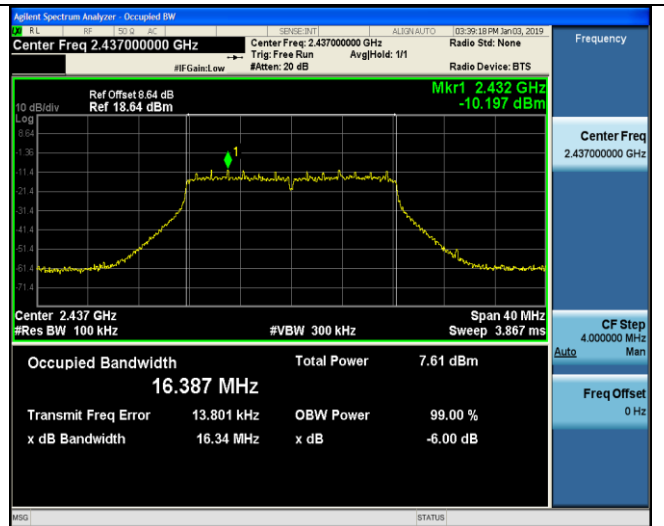

CH06



CH06

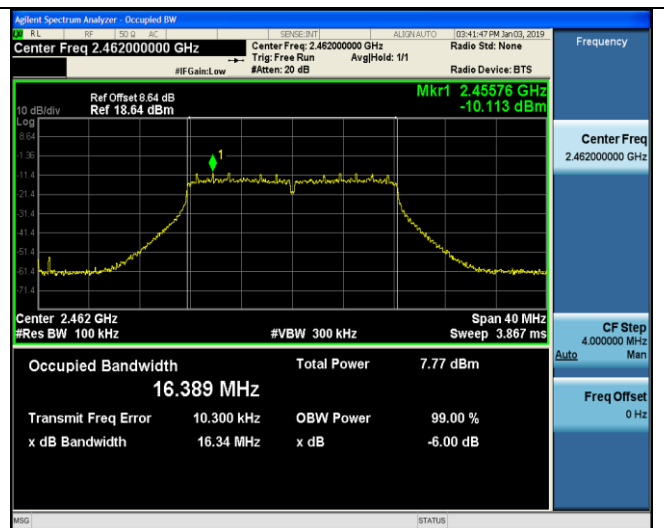

CH11

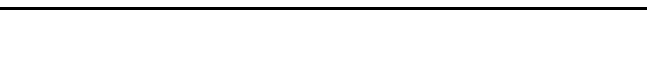

CH11

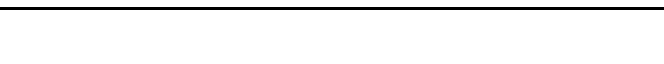





802.11n(HT20)

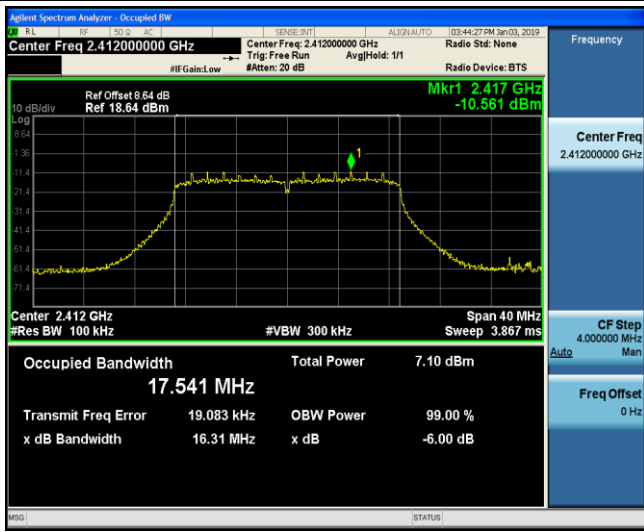

CH01

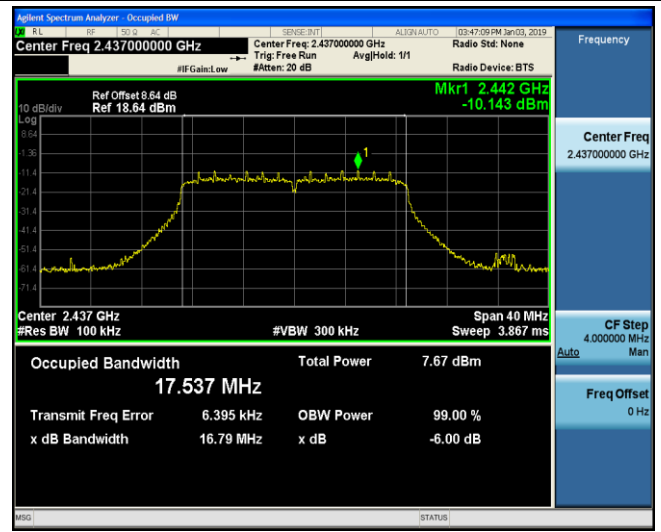

CH06

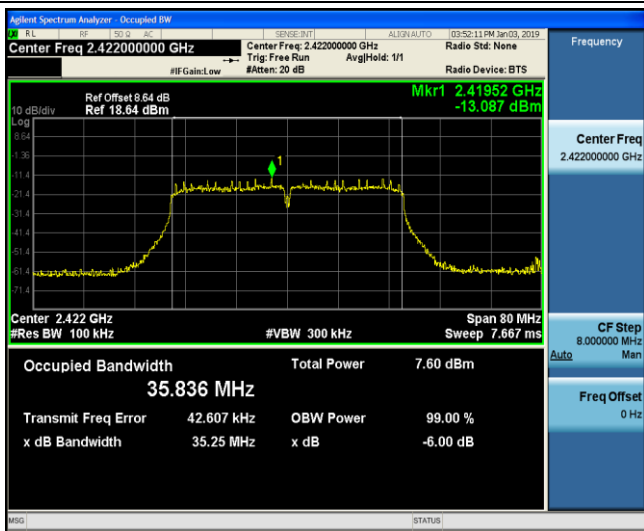

CH11



### 3.6. Out-of-band Emissions

#### Limit

In any 100 kHz bandwidth outside the frequency band in which the spread spectrum or digitally modulated intentional radiator is operating, the radio frequency power that is produced by the intentional radiator shall be at least 20 dB below that in the 100 kHz bandwidth within the band that contains the highest level of the desired power, based on either an RF conducted or a radiated measurement, provided the transmitter demonstrates compliance with the peak conducted power limits. If the transmitter complies with the conducted power limits based on the use of RMS averaging over a time interval, as permitted under paragraph (b)(3) of this section, the attenuation required under this paragraph shall be 30 dB instead of 20 dB. Attenuation below the general limits specified in §15.209(a) is not required.

#### Test Procedure

Connect the transmitter output to spectrum analyzer using a low loss RF cable, and set the spectrum analyzer to RBW=100 kHz, VBW= 300 kHz, peak detector, and max hold. Measurements utilizing these settings are made of the in-band reference level, band-edge and out-of-band emissions.

#### Test Configuration

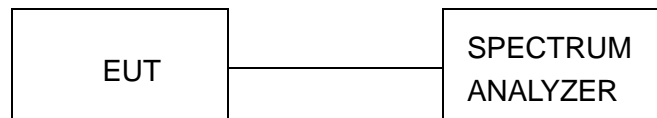

#### Test Results

Remark: The measurement frequency range is from 30MHz to the 10th harmonic of the fundamental frequency. The lowest, middle and highest channels are tested to verify the spurious emissions and band-edge measurement data. And record the worst data in the report.

Test plot as follows:



802.11b CH01



802.11b CH06



Reference

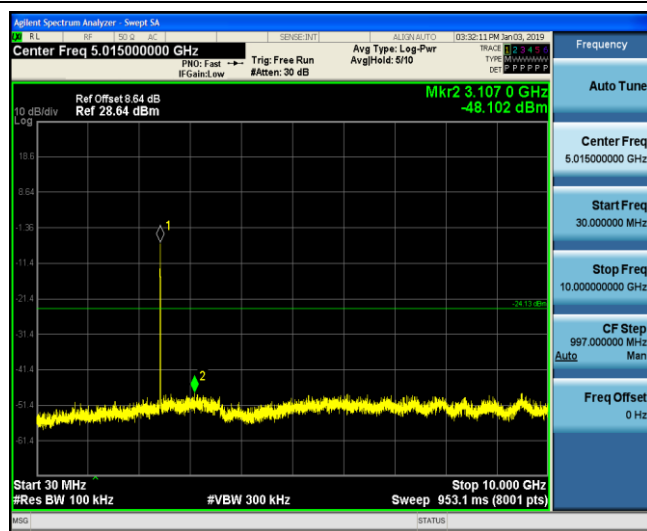
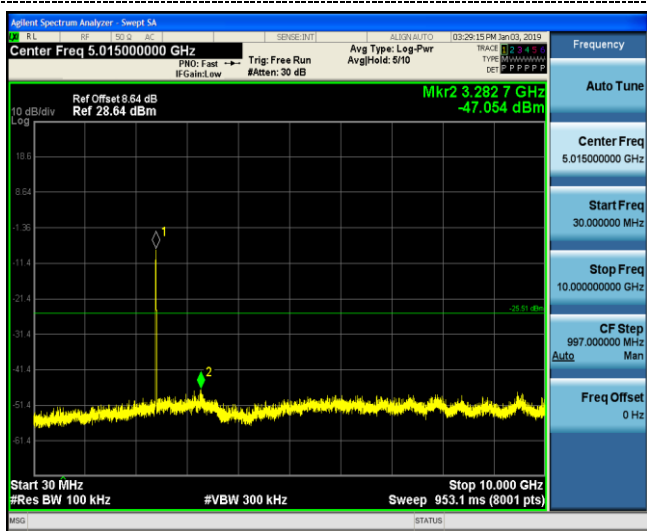

30MHz-10GHz



30MHz-10GHz



10GHz-26GHz

10GHz-26GHz



802.11b CH11



802.11g CH01

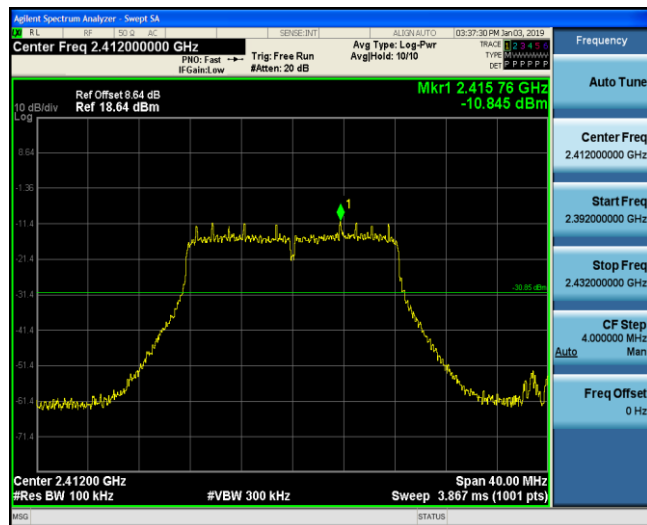

Reference

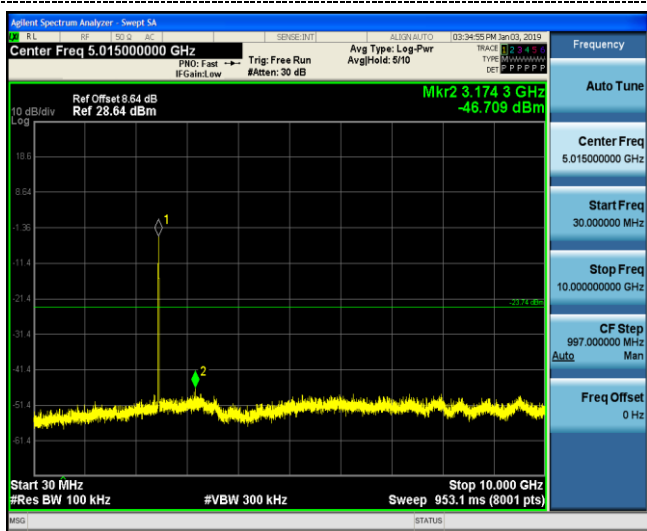

Reference

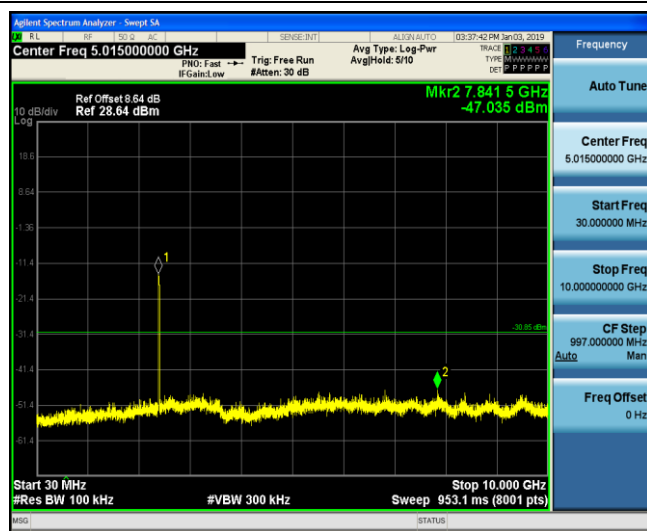

30MHz-10GHz



30MHz-10GHz



10GHz-26GHz

10GHz-26GHz



### 802.11g CH06

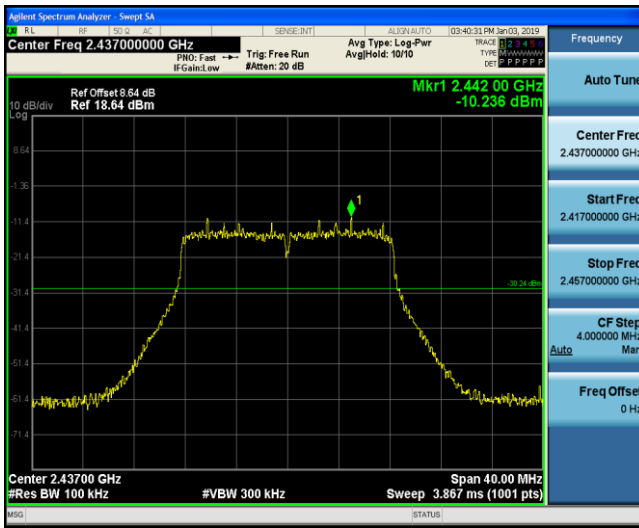

### 802.11g CH11

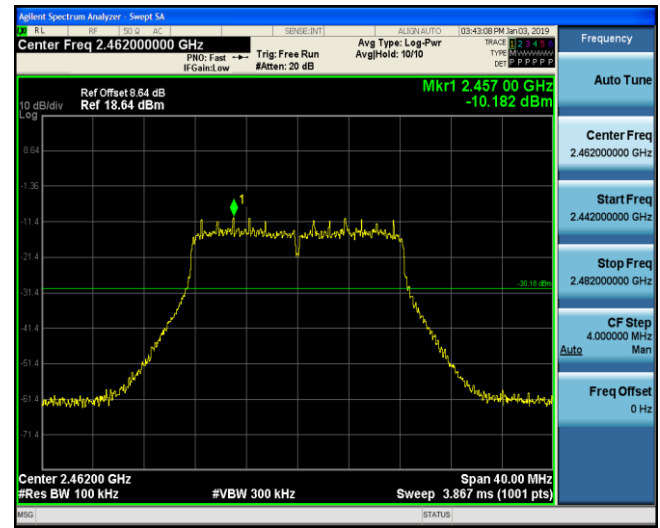

### Reference

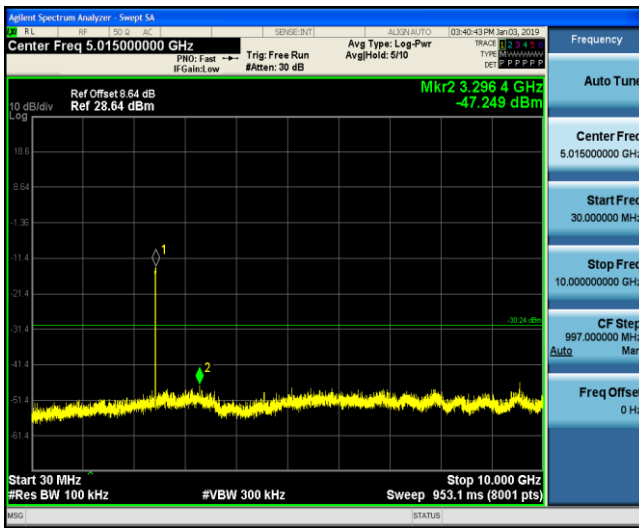

### Reference

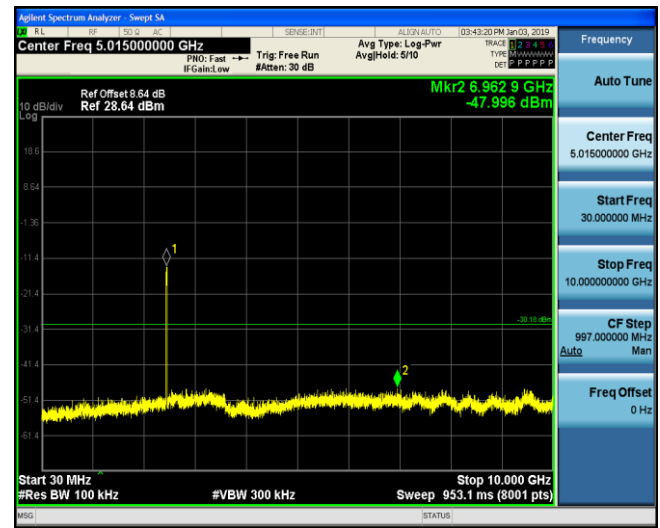

### 30MHz-10GHz



### 30MHz-10GHz



### 10GHz-26GHz

### 10GHz-26GHz



802.11n(HT20) CH01

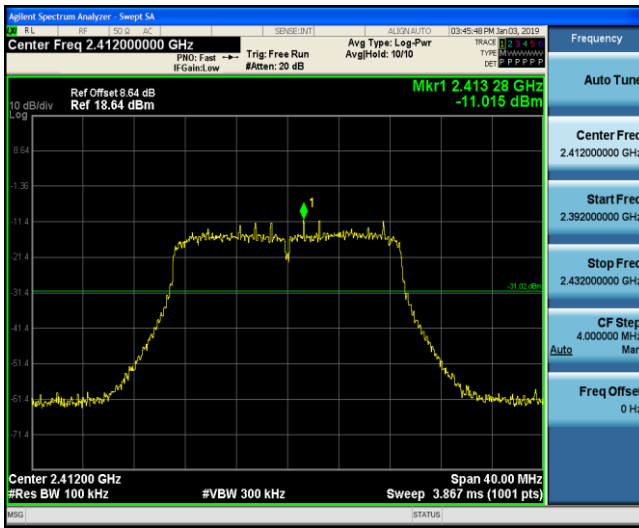

802.11n(HT20) CH06

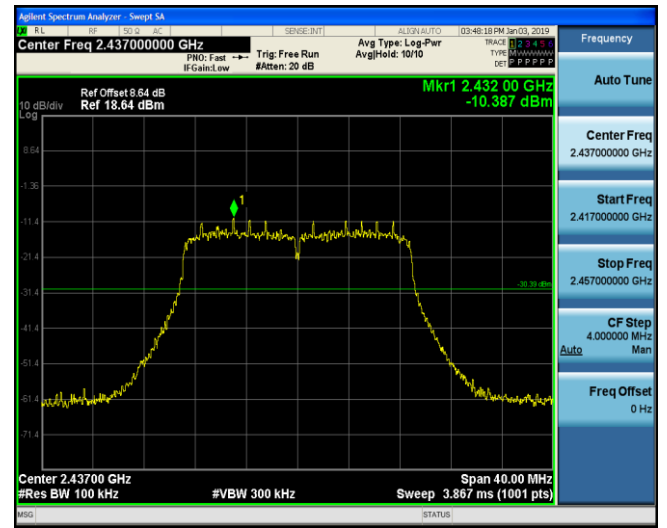

Reference

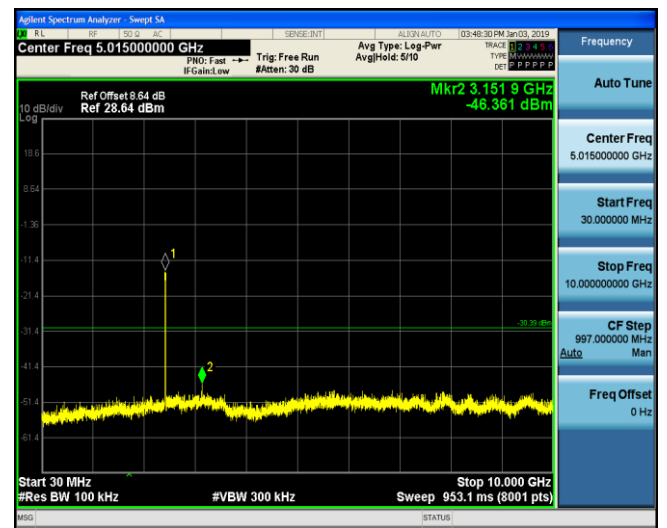
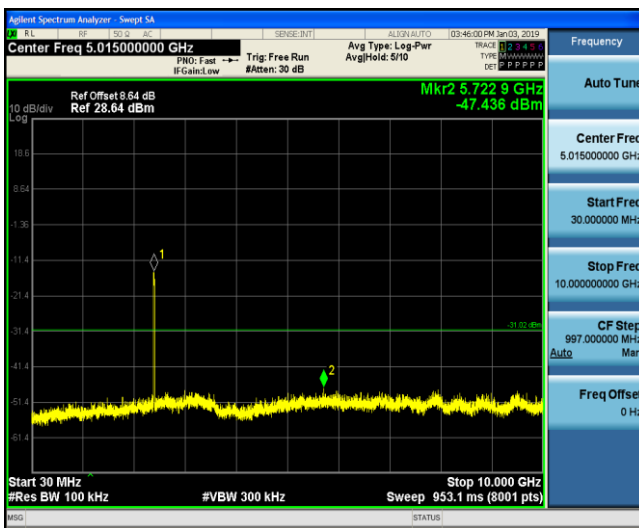

30MHz-10GHz



30MHz-10GHz



10GHz-26GHz

10GHz-26GHz



802.11n(HT20) CH11

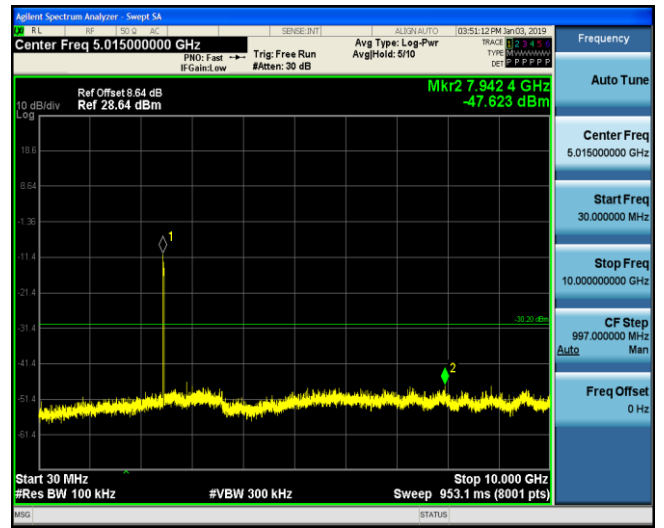
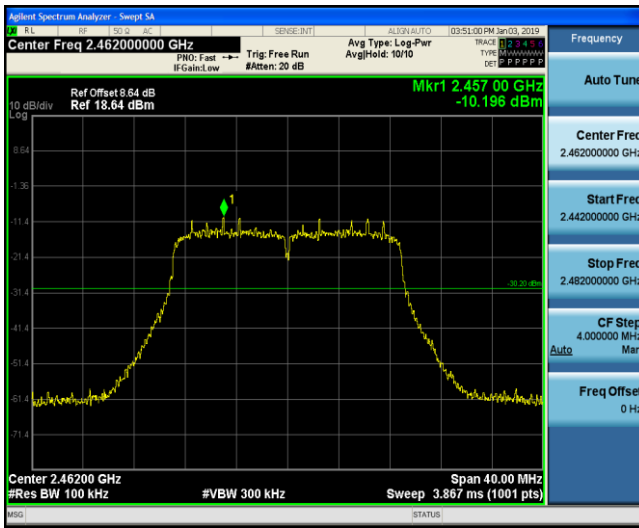

Reference

30MHz-10GHz



10GHz-26GHz



**Band-edge Measurements for RF Conducted Emissions:**

802.11b			
Frequency (MHz)	Delta Peak to Band emission (dBc)	Limit (dBc)	Verdict
2400.00	-47.611	-20	PASS
2483.50	-57.584	-20	PASS

	2412
	2462

802.11g			
Frequency (MHz)	Delta Peak to Band emission (dBc)	Limit (dBc)	Verdict
2400.00	-42.892	-20	PASS
2483.05	-50.531	-20	PASS

	2412
	2462





802.11n HT20

Frequency (MHz)	Delta Peak to Band emission (dBc)	Limit (dBc)	Verdict
2400.00	-41.569	-20	PASS
2483.50	-51.421	-20	PASS

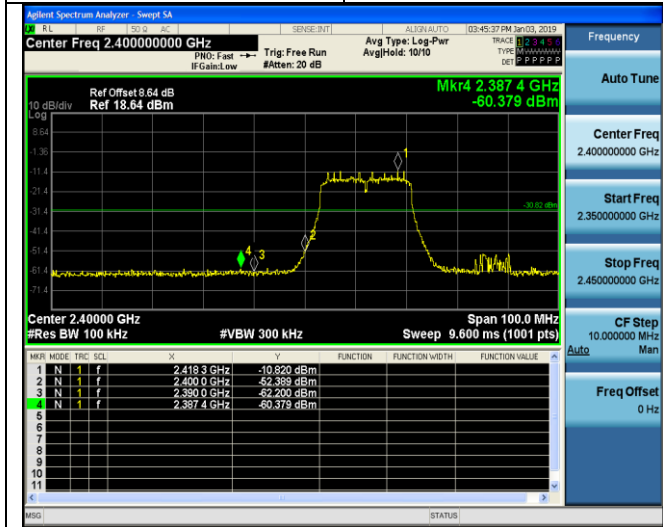

2412

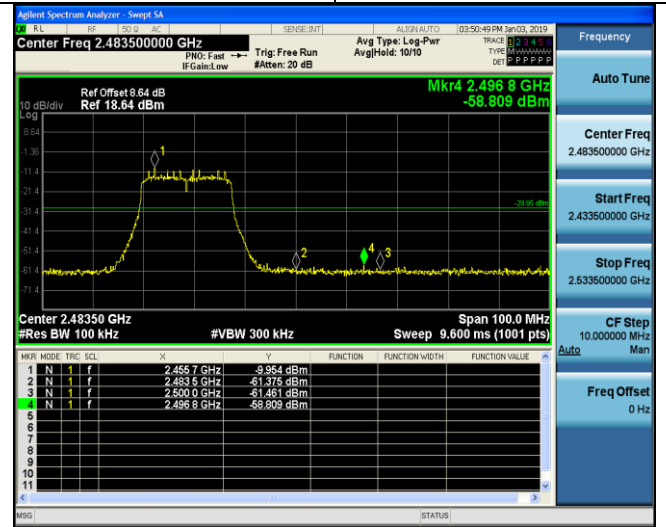

2462



### 3.7. Antenna Requirement

#### **Standard Applicable**

**For intentional device, according to FCC 47 CFR Section 15.203:**

An intentional radiator shall be designed to ensure that no antenna other than that furnished by the responsible party shall be used with the device. The use of a permanently attached antenna or of an antenna that uses a unique coupling to the intentional radiator, the manufacturer may design the unit so that a broken antenna can be replaced by the user, but the use of a standard antenna jack or electrical connector is prohibited

**FCC CFR Title 47 Part 15 Subpart C Section 15.247(c) (1) (I):**

(i) Systems operating in the 2400-2483.5 MHz band that is used exclusively for fixed. Point-to-point operations may employ transmitting antennas with directional gain greater than 6dBi provided the maximum conducted output power of the intentional radiator is reduced by 1 dB for every 3 dB that the directional gain of the antenna exceeds 6dBi.

#### **Test Result:**

The maximum gain of antenna was 3.23 dBi for 2.4GHz WIFI.



## 4. Test Setup Photos of the EUT



\*\*\*\*\* End of Report \*\*\*\*\*