

QUICK START GUIDE

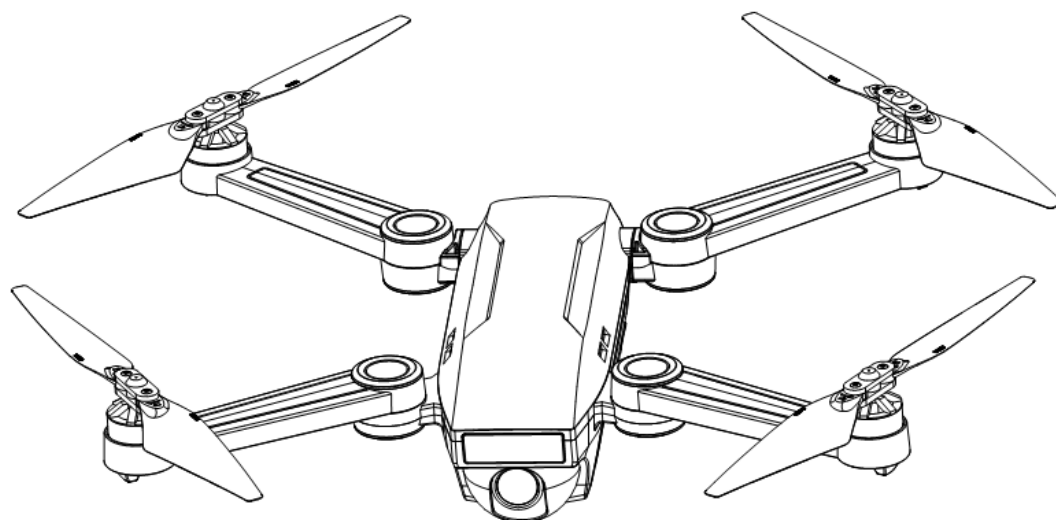

Overview of TE-F360

TOPE TE-F360 Quadcopter is foldable, handy & convenient with dual-mode GPS, Pneumatic sensor system, gyroscope sensor system for superior axis control, intelligent follow feature, waypoint flight, and more. Supports gestures photo, automatic return, stable hover and flight indoors and outdoors. Records 1080P HD video and takes HD photos with double anti-shock structure camera. Flying time is about 25 minutes.

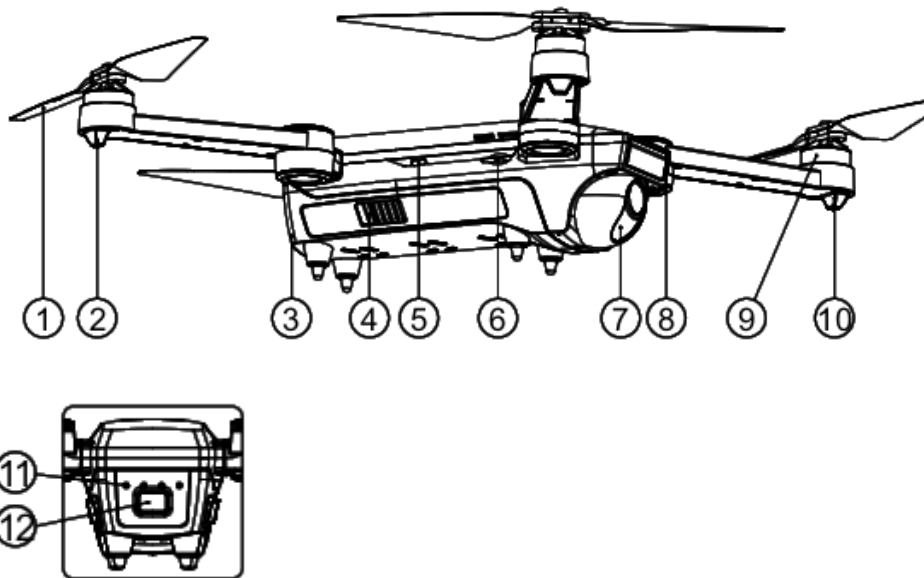

1. Propellers
2. Aircraft Status Indicator
3. Intelligent Flight Battery
4. Battery Clip
5. Micro USB Port
6. Micro SD Card Slot
7. Camera
8. Front LED Indicator
9. Motor
10. Quadcopter Arm Indicator
11. Power Indicator
12. Battery Switch

Overview of Remote Controller

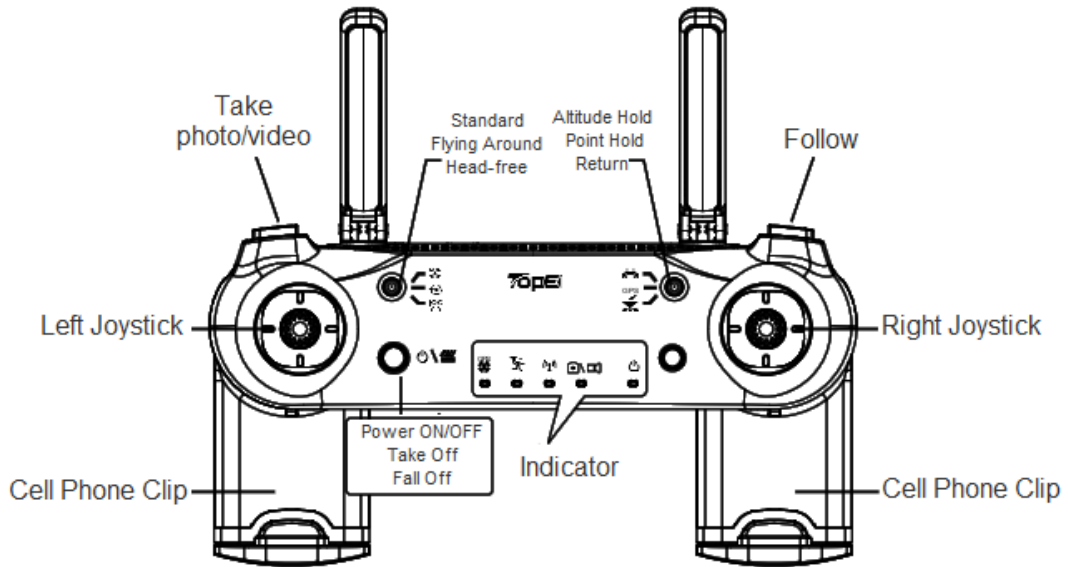

*To prepare for your first flight, please read the Guidelines and Disclaimer to understand safety precautions, and watch video tutorials on TOPE APP for correct use.

*The flying time is tested in hovering mode without wind.

Scan to download TOPEUAV APP



DOMESTIC ANDROID



FOREIGN ANDROID



IOS

TOPEUAV APP supports IOS 9.0 and Android 4.4, or later versions.

Prepare Battery

Please charge to active power before using for the first time.

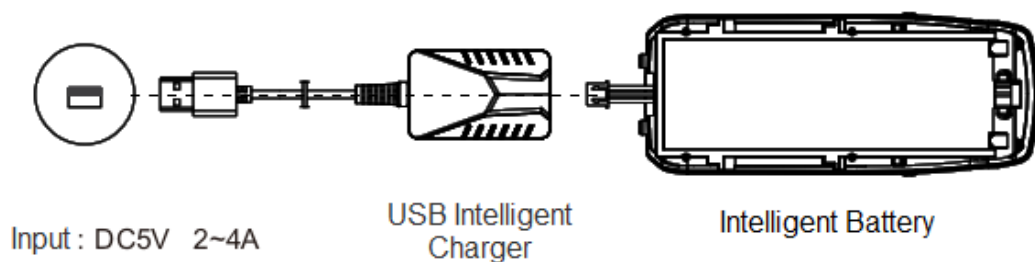

Battery is fully charged once all power indicators turn green, which takes about 3 – 5 hours.

Press the power button once to check power level.

Turning On or Turning Off the Battery

Press the power button once and release. With LED flashing, press again and hold for 3 seconds to turn on battery, then LEDs will light up.

Press the power button and hold for 3 seconds to turn Off battery, then LEDs will turn off.

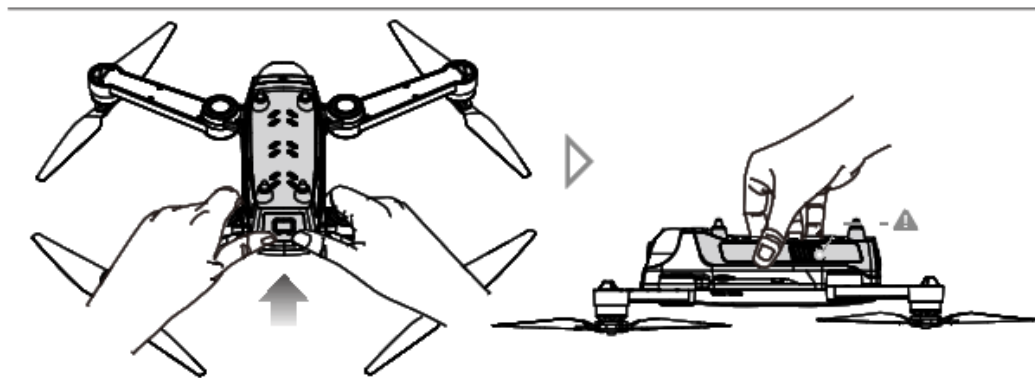

 Hold aircraft arm and push intelligent flight battery to the bottom

Open the Aircraft

▲ Expand the four arms according to the folding image stickers on the aircraft. Turn on the aircraft power, place it on a horizontal surface and straighten the propellers.

▲ At this time, the aircraft will automatically enter self-testing status, the aircraft indicator is on, and the yellow light flashes after the self-testing is completed.

▲ Then the aircraft will automatically search for GPS satellites. Once it connects to multiple satellites, the green light flashes, indicating that GPS-related operations can start.

Open the Remote Controller

▲ The aircraft and remote controller have been paired by default, no need to re-pair.

▲ Push both three-way switches to the front.

▲ Press and hold power switch until a “beep” is heard, release the power switch to finish, then power indicator will remain on. At this time, the indicator light of remote indicates that the aircraft has been properly connected with the remote controller.

Switch Control Mode

▲ The remote controller defaults to US hand mode, which can be switched back and forth as follows.

▲ First, press top-right and top-left buttons of the remote controller at the same time, second, press and hold the power button until all four signal lights turn on, then release all buttons. At this time, the remote controller will make audio sounds. US hand mode is indicated with one “beep”, and JP hand mode is indicated with two “beeps”. At the same time, the four lights flash slowly and then flash quickly, and the power indicator remains on after the flash is over, which means the switch has completed successfully.

▲Note: The joystick cannot be touched during mode switching.

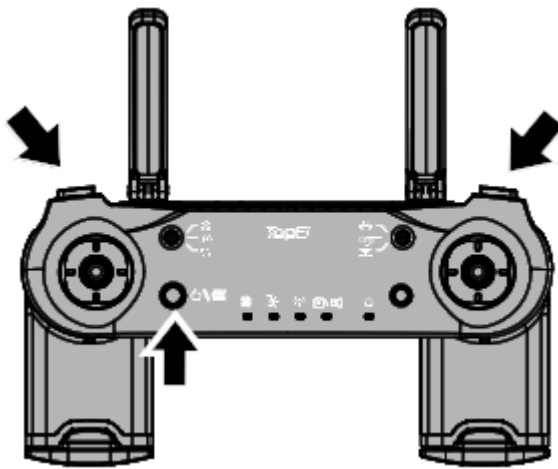

Connect APP



Turn on Aircraft



Connect Wifi with Mobiles



TOPEUAV
App

Run TOPEUAV App

Remote Control

The Remote Control is configured for US mode and JP mode as following

US mode (Left Hand Throttle)

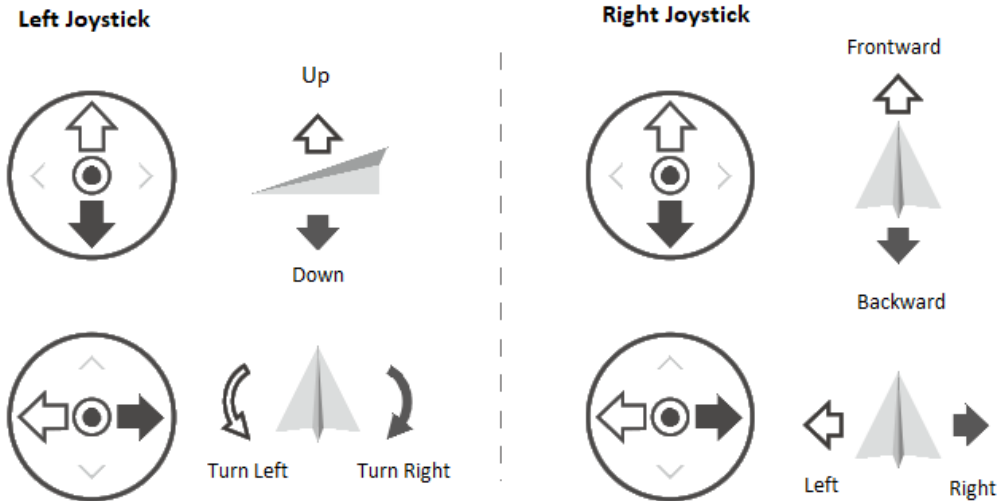

JP mode (Right Hand Throttle)

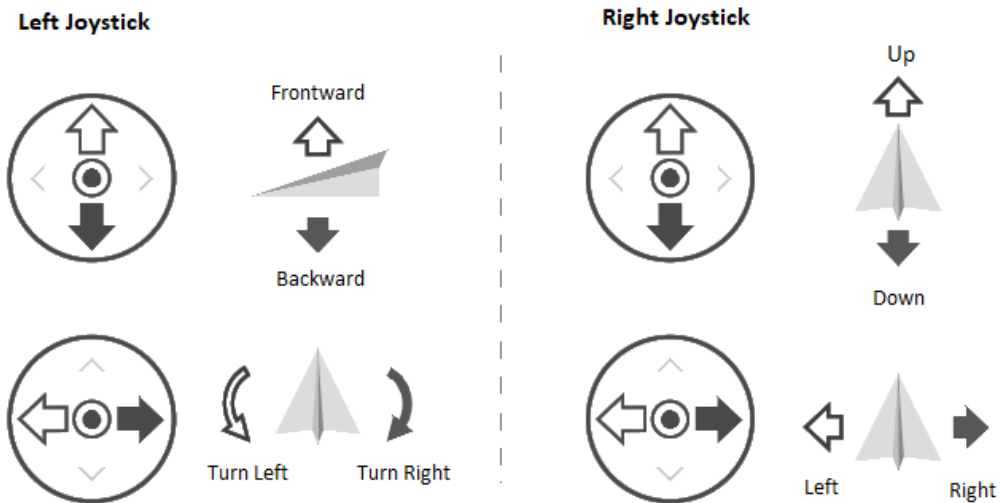

Calibrate Compass

▲ Turn on the aircraft and remote controller, after the aircraft self-test is completed, pull the remote controller throttle stick to the bottom and push forward and backward joystick to the top. Release all the joystick controls until the aircraft indicators light alternately in yellow and green.

- ▲ Lift the aircraft from the rear horizontally and turn it 5 times in a clockwise direction.
- ▲ The signal light turns red slowly, which indicates the calibration is successful.

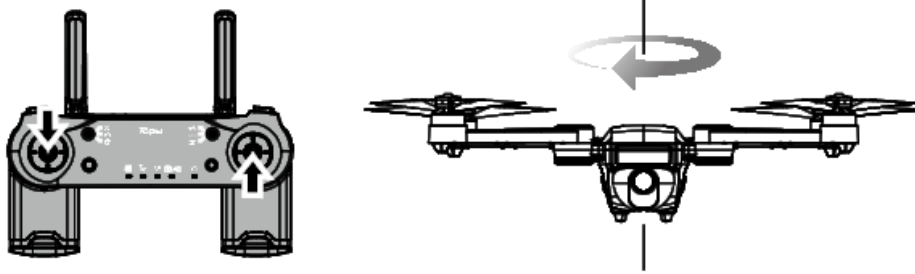

Start Motor

The motor will be started by executing a swing motion with the joystick. Then release joystick immediately after the motor starts to rotate.

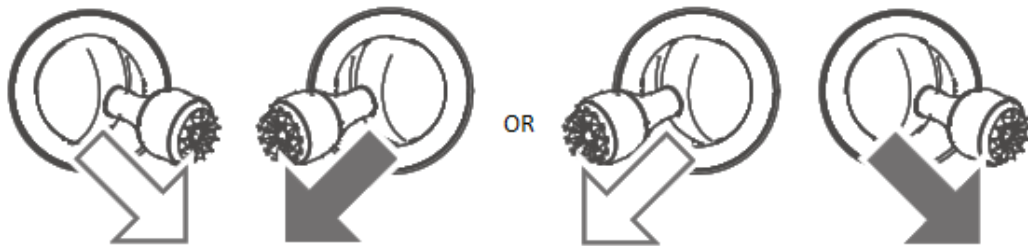

Stop Motor

After aircraft lands, push the throttle stick to lowest position and hold for several seconds to stop the motor.



Specifications

● **Aircraft**

- Net Weight 530g
- Flying Time Around 25 Min
- Wi-Fi 300500M
- Motor Type 1806 Motor
- Cruiser Support
- GPS Mode GPS/GLONASS(Dual Mode)
- Dimensions 50*50*9cm (Full Size) 19*13*9cm (Folded size)
- Propellers Released Yes
- Propellers Foldable Yes
- Aircraft Foldable(Portable): Yes
- Failsafe and Return Yes (Automatically return to takeoff location once out of control range in GPS mode)

● **Camera**

- Camera Lens: FOV 150/2.0
- Photo Mode: Single Shot/ Multi-shot
- Video Record: HD1080P 25
- Image Format: JPEG
- Video Format: MP4
- Memory Card: Supports TF Card (Maximum 32GB)

● **Power**

- Battery Capacity: 4000mAh (25.9Wh)
- Battery Voltage: 7.6V (2S)
- Charging Time: 3-5 Hours
- Charging Method USB Charger
(Optional: USB power adapter 2A/4A)

● **Remote Controller**

- Frequency: 2.4G Remote Controller (Supports control on ground by phone app)
- Max. Distance: About 1000m
- Power of Controller: 3.7V/650Ah

FCC Statement

This equipment has been tested and found to comply with the limits for a Class B digital device, pursuant to Part 15 of the FCC Rules. These limits are designed to provide reasonable protection against harmful interference in a residential installation. This equipment generates uses and can radiate radio frequency energy and, if not installed and used in accordance with the instructions, may cause harmful interference to radio communications. However, there is no guarantee that interference will not occur in a particular installation. If this equipment does cause harmful interference to radio or television reception, which can be determined by turning the equipment off and on, the user is encouraged to try to correct the interference by one or more of the following measures:

- Reorient or relocate the receiving antenna.
- Increase the separation between the equipment and receiver.
- Connect the equipment into an outlet on a circuit different from that to which the receiver is connected.
- Consult the dealer or an experienced radio/TV technician for help.

Changes or modifications not expressly approved by the party responsible for compliance could void the user's authority to operate the equipment.

This device complies with part 15 of the FCC Rules. Operation is subject to the following two conditions:

- (1) This device may not cause harmful interference, and
- (2) this device must accept any interference received, including interference that may cause undesired operation.