

User Manual

Model : HB-USP-GT1L-B



44-10, Techno10-ro, Yuseong-gu, Daejeon 305-510, Korea.

TEL) 042-862-5882

FAX) 042-932-9624

Chapter 1. Overview

1.1 Overview of Product

HB-USP-GT1L-B is a model that receives input from various sensors of voltage, current and resistive output types and transfers processed data via Bluetooth wireless communication. Data obtained from each sensor are sent to sink node (HB-USP-GT2-B), and they can be sent from the sink node to a monitoring device through Ethernet. Data can be checked from a remote distance by configuring additional network using the internet or Wi-Fi.

1.2 Composition of Product

Name	Quantity	Remark
Main body (HB-USP-GT1L-B)	1	
Sensor connector	6	Connector to connect main body and sensor
Power adapter	1	Input : AC100~240V(50/60Hz) Output : DC5V $\overline{\text{---}}$ 4A
RF antenna	1	Helical antenna (2.4GHz, 2.85 dBi)
Ferrite core	4	Attached to sensor cable

* $\overline{\text{---}}$: Direct current

1.2.1 Main Body

HB-USP-GT1L-B consists of sensor connection part, power terminal, RF antenna and LED.



1.2.2 Sensor Connector

Sensor connector is a connector used to connect the sensor connection part of HB-USP-GT1L-B with sensor. One connector consists of 4 pins, and connectors are provided as appropriate for the number of channels.



1.2.3 Power Adaptor

Power adaptor is a device that supplies power to operate the main body of sensor node. Power input is AC 100~240V (50/60Hz) and output is DC5V, 1A.



1.2.4 RF Antenna

RF antenna is an external antenna connected to Bluetooth module.



1.2.5 Ferrite Core

Ferrite core attached to sensor cable prevents electrical noise on the sensor cable.



1.3 Classification of Model According to Sensor Input

Sensor Input		No. of Channels	Remark
DC input	Voltage	4CH	DC 0~5V
	Current	4CH	DC 4~20mA
	Resistive	4CH	0~20k Ω

Chapter 2. Product Description

2.1 Specifications

Specifications of this product are as follows.

Hardware			
Microprocessor	STM32L051 (32bit, ARM cortex-M0)		
Memory	64Kbyte program memory		
	8KByte SRAM		
Clock Speed	32MHz		
RF	Bluetooth		
Serial	RS-485		
RF Interface			
Protocol	Bluetooth 2.0 + EDR, Class2		
Communication Speed	921,600 bps		
Communication Distance	50m		
Frequency Range	2,402MHz ~ 2,480MHz		
Transmission Power	2 dBm(Typical)		
Antenna	Helical, 2.85 dBi, SMA type		
Analog Sensor Input (CH1 ~ CH4)			
Sensor Input Type	DC voltage	DC current	Resistive
Number of Channels	4	4	4
ADC Resolution	12bit		
Sampling Cycle	7.68kSPS (sample per second)		
Input Range	DC 0~5V	DC 4~20mA	0~20kΩ
Analog Sensor Power Supply			
Voltage	DC 5V		
Power and Environment			
Input Voltage Range	4.8V ~ 5.2V		
Operation Temperature	-20 °C ~ 60 °C		
Storage Temperature	-30 °C ~ 70 °C		
Case Materials	ABS (Acrylnitrile-Butadiene-Styrene)		
Weight	120 g		
Dimension	55 x 80 x 30 mm (W x H x D), except RF antenna		

* The Battery is not replaceable.

2.1.1 Name of Each Part

Name and function of each part of this product are as follows.

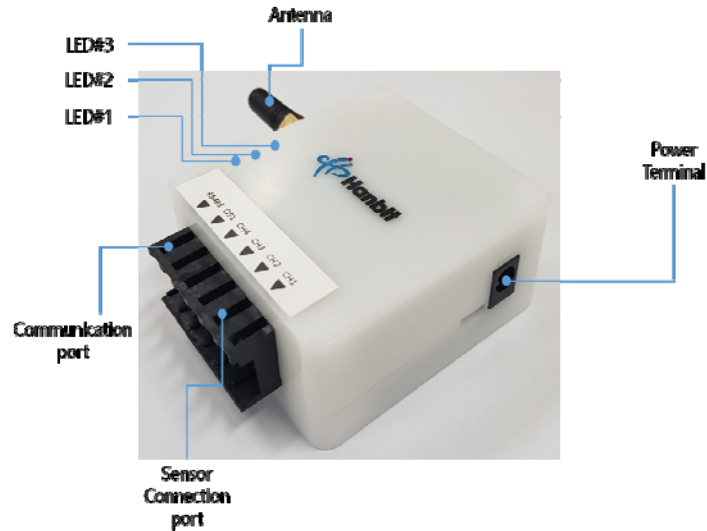

○ Power terminal	This is power input terminal to operate the main body of sensor node. Power adaptor provided upon purchase is connected to this terminal.
○ Sensor connection part (CH1 ~ CH4)	This part is connected to the analog sensor. It can receive input from voltage sensor of DC0~5V, current sensor of DC 4~20mA or resistive sensor. It has 4 channels, and each channel has 4 pins. Among them, 2 pins are connected to sensor output and 2 pins are used to supply voltage of DC5V for sensors that require power.
○ Communication port	This port is used for RS-485, a representative method of serial communication. It is used for setting upon shipment. Default value is 57,600bps.
○ LEDs	This product has 3 LEDs. <ul style="list-style-type: none"> - LED #1: Turned ON when wireless module is normal - LED #2: Turned ON when connecting to nearby sink node (GT2-B) module and turned OFF once connected - LED #3: No function
○ Antenna	This helical communication antenna is connected to the internal RF module. Antenna gain is 2.85 dBi.

2.2 Hardware Description

2.2.1 Block Diagram

The figure below shows block diagram of the product hardware.

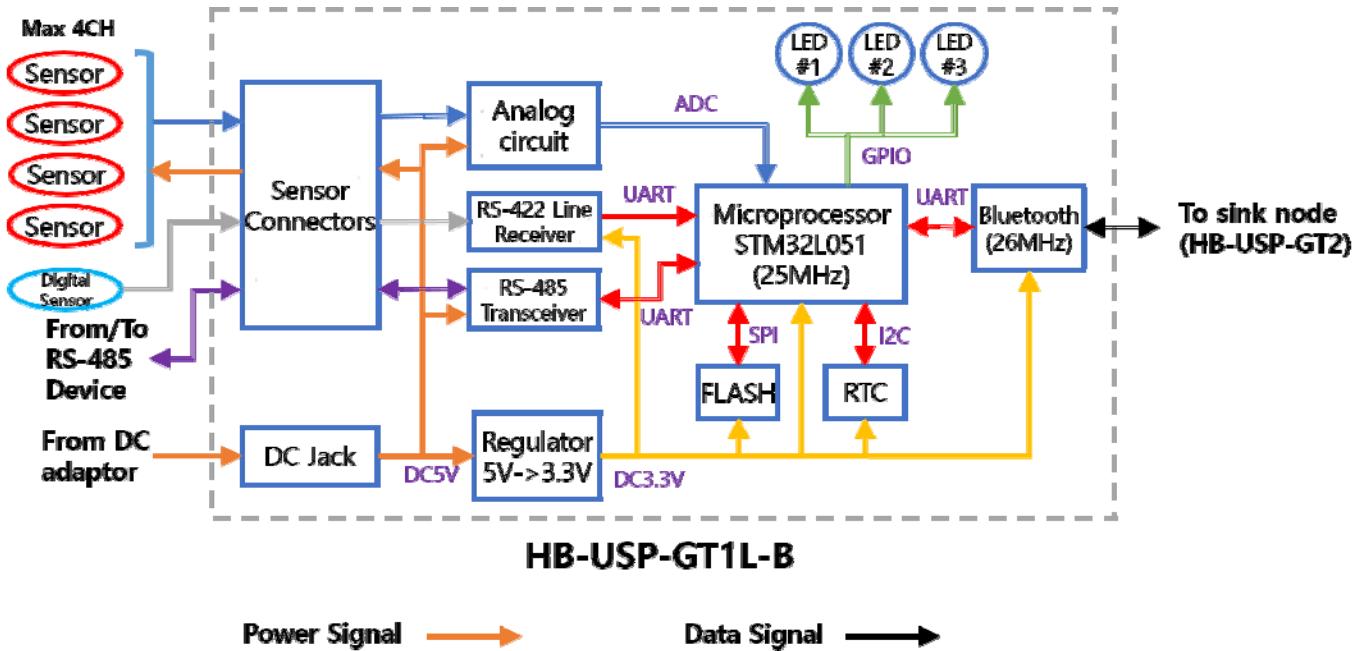

<Block Diagram of HB-USP-GT1L-B>

This product is operated by receiving 5V from DC adaptor. Voltage of 5V is supplied to analog circuit, RS-485 circuit, and sensor that requires power via sensor connector. DC5V voltage is passed through regulator and converted to 3.3V, and 3.3V is supplied to microprocessor, digital sensor circuit, internal flash, RTC and Bluetooth module.

Sensor signals obtained from sensors are passed through the analog circuit and sent to ADC input of the microprocessor. The microprocessor handles and processes data, and it can send data via Bluetooth module or RS-485 port. When sending data using the Bluetooth module, sink node is used. Communication method can be switched to Ethernet on the sink node.

Various settings are saved on flash, which is loaded automatically upon booting. Setting values are saved automatically when network device information is updated.

FCC Compliance Statement

This equipment has been tested and complies with the limits for a Class A digital device, pursuant to Part 15 of the FCC Rules. These limits are designed to provide reasonable protection against harmful interference when the equipment is operated in a commercial environment. This equipment generates, uses, and can radiate radio frequency energy and, if not installed and used in accordance with the instruction manual, may cause harmful interference to radio communications. Operation of this equipment in a residential area is likely to cause harmful interference, in which case the user will be required to correct the interference at his own expense.

This device complies with Part 15 of the FCC Rules. Operation is subject to the following two conditions: (1) this device may not cause harmful interference, and (2) this device must accept any interference received, including interference that may cause undesired operation.

Any changes or modifications to the equipment not expressly approved by the party responsible for compliance could void user's authority to operate the equipment.