

5GHz Wireless Audio Transceiver

ATM511

DATASHEET

REV01

DEC 15, 2021



SEONG JI INDUSTRIAL CO., LTD

54-33, Dongtanhana 1-gil, Hwaseong-si, Gyeonggi-do, South Korea

Table of Contents

1. Revision History	3
2. Scope	4
3. Product Information	4
3-1. Product Information	4
3-2. Part Number	4
3-3. Lot Number	5
4. Operating Description	6
5. Product Information	9
5-1. Absolute Maximum Ratings	9
5-2. Recommended operating Range	9
5-3. Electrical Characteristics – DC	9
5-4. Electrical Characteristics – RF TX	10
5-5. Electrical Characteristics – RF RX	11
5-6. Electrical Characteristics – RF PLL	11
5-7. Electrical Characteristics – Audio C/CS	11
5-8. I2S Communication Interface Timing	12
5-9. I2C Slave Communication Interface Timing	13
6. I/O Connector Pin Description	14
7. Mechanical Specifications	15
7-1. Module dimension	15
7-2. Antenna dimension	15
8. Label Specification	16
8-1. Label Information Descriptions	16
8-2. Label Size and attach	16
9. Certificate Statement	17

1. Revision History

No.	Revision	Content	Date	Revision Page
1	01	Initial Release	2012-12-15	

2. Scope

This document is the specifications of 5GHz wireless audio transceiver module, ATM511.

3. Product Information

3-1. Product Information

ITEMS	DESCRIPTION
Manufacturer	SEONG JI INDUSTRIAL CO.,LTD
Customer	
Customer Project	
Product Application	Wireless Audio Transceiver
Product Name	ATM511
Part Number	TX : WSATM511A00 RX : WSATM511A10
Regulatory Certification	
● FCC	2AS8LATM510
● IC	25119-ATM510
● CE	TBD
Firmware Version	SSB TX : 2.0.15 RX : 2.0.1 DSB TX : 3.0.15 RX : 3.0.1

3-2. Part Number

W	S	A	T	M	5	1	1	A	0	0
(1)	(2)	(3)	(4)	(5)	(6)	(7)	(8)	(9)	(10)	(11)

No.	EXPLANATION
(1),(2)	Wireless Solution
(3),(4)	Application (AT: Audio Transceiver)
(5)	Type (M:Module)
(6)	Group model : Main Chip (5: SKY76303 IC)
(7)	Development Code (0: w/PA, 1: w/o PA)
(8)	Development Code (0: Supply Voltage +5V, 1: Supply Voltage +3.3V)
(9)	Customer Code (A :)
(10),(11)	Firmware application (00 : TX, 10 : RX)

3-3. Lot Number

A	A	F	L	N	5	1	0	1
(1)	(2)	(3)	(4)	(5)	(6)	(7)	(8)	(9)

No.	EXPLANATION																																																																								
①	Blue Tooth(B), Wi-Fi(W), Zigbee(Z), Combo(C) , NFC(N), Audio (A)																																																																								
②	Manufacture Area <table border="1" style="width: 100%; text-align: center;"> <thead> <tr> <th style="background-color: #d3d3d3;">Packing Lot</th> <th>A</th> <th>B</th> <th>C</th> </tr> </thead> <tbody> <tr> <td style="background-color: #d3d3d3;">Area</td> <td>Korea</td> <td>China</td> <td>Vietnam</td> </tr> </tbody> </table>	Packing Lot	A	B	C	Area	Korea	China	Vietnam																																																																
Packing Lot	A	B	C																																																																						
Area	Korea	China	Vietnam																																																																						
③	Year <table border="1" style="width: 100%; text-align: center;"> <thead> <tr> <th style="background-color: #d3d3d3;">Year</th> <th>2018</th> <th>2019</th> <th>2020</th> <th>2021</th> <th>2022</th> <th>2023</th> <th>2024</th> <th>2025</th> <th>2026</th> <th>2027</th> </tr> </thead> <tbody> <tr> <td style="background-color: #d3d3d3;">Mark</td> <td>E</td> <td>F</td> <td>G</td> <td>H</td> <td>I</td> <td>J</td> <td>K</td> <td>L</td> <td>M</td> <td>N</td> </tr> </tbody> </table>	Year	2018	2019	2020	2021	2022	2023	2024	2025	2026	2027	Mark	E	F	G	H	I	J	K	L	M	N																																																		
Year	2018	2019	2020	2021	2022	2023	2024	2025	2026	2027																																																															
Mark	E	F	G	H	I	J	K	L	M	N																																																															
④	Month <table border="1" style="width: 100%; text-align: center;"> <thead> <tr> <th style="background-color: #d3d3d3;">Month</th> <th>1</th> <th>2</th> <th>3</th> <th>4</th> <th>5</th> <th>6</th> <th>7</th> <th>8</th> <th>9</th> <th>10</th> <th>11</th> <th>12</th> </tr> </thead> <tbody> <tr> <td style="background-color: #d3d3d3;">Mark</td> <td>A</td> <td>B</td> <td>C</td> <td>D</td> <td>E</td> <td>F</td> <td>G</td> <td>H</td> <td>I</td> <td>J</td> <td>K</td> <td>L</td> </tr> </tbody> </table>	Month	1	2	3	4	5	6	7	8	9	10	11	12	Mark	A	B	C	D	E	F	G	H	I	J	K	L																																														
Month	1	2	3	4	5	6	7	8	9	10	11	12																																																													
Mark	A	B	C	D	E	F	G	H	I	J	K	L																																																													
⑤	Day <table border="1" style="width: 100%; text-align: center;"> <thead> <tr> <th style="background-color: #d3d3d3;">Day</th> <th>1</th> <th>2</th> <th>3</th> <th>4</th> <th>5</th> <th>6</th> <th>7</th> <th>8</th> <th>9</th> <th>10</th> <th></th> </tr> </thead> <tbody> <tr> <td style="background-color: #d3d3d3;">Mark</td> <td>1</td> <td>2</td> <td>3</td> <td>4</td> <td>5</td> <td>6</td> <td>7</td> <td>8</td> <td>9</td> <td>A</td> <td></td> </tr> <tr> <th style="background-color: #d3d3d3;">Day</th> <th>11</th> <th>12</th> <th>13</th> <th>14</th> <th>15</th> <th>16</th> <th>17</th> <th>18</th> <th>19</th> <th>20</th> <th></th> </tr> <tr> <td style="background-color: #d3d3d3;">Mark</td> <td>B</td> <td>C</td> <td>D</td> <td>E</td> <td>F</td> <td>G</td> <td>H</td> <td>I</td> <td>J</td> <td>K</td> <td></td> </tr> <tr> <th style="background-color: #d3d3d3;">Day</th> <th>21</th> <th>22</th> <th>23</th> <th>24</th> <th>25</th> <th>26</th> <th>27</th> <th>28</th> <th>29</th> <th>30</th> <th>31</th> </tr> <tr> <td style="background-color: #d3d3d3;">Mark</td> <td>L</td> <td>M</td> <td>N</td> <td>O</td> <td>P</td> <td>Q</td> <td>R</td> <td>S</td> <td>T</td> <td>U</td> <td>V</td> </tr> </tbody> </table>	Day	1	2	3	4	5	6	7	8	9	10		Mark	1	2	3	4	5	6	7	8	9	A		Day	11	12	13	14	15	16	17	18	19	20		Mark	B	C	D	E	F	G	H	I	J	K		Day	21	22	23	24	25	26	27	28	29	30	31	Mark	L	M	N	O	P	Q	R	S	T	U	V
Day	1	2	3	4	5	6	7	8	9	10																																																															
Mark	1	2	3	4	5	6	7	8	9	A																																																															
Day	11	12	13	14	15	16	17	18	19	20																																																															
Mark	B	C	D	E	F	G	H	I	J	K																																																															
Day	21	22	23	24	25	26	27	28	29	30	31																																																														
Mark	L	M	N	O	P	Q	R	S	T	U	V																																																														
⑥,⑦	Model Serial Number (0,1,2,3...), ATM511 : 11																																																																								
⑧,⑨	A Serial Number(1Serial : 1Box)																																																																								

4. Operating Description

The SKY76303 SoC has the VMI RF protocol, providing an excellent coexistence performance and also provide the capabilities of world-class wireless audio protocol by supporting increased digital I/O and OTA (over-the air) signal routing flexibility to accommodate a wide range of wireless audio application. It features low fixed latency, multiple OTA audio configurations, uncompressed up to 24bit audio quality mono or stereo audio, excellent interference immunity, and inherent coexistence with WIFI.

The IC contains all the necessary radio transceiver and digital baseband circuitry to form a complete digital wireless node without the need for external processing as well as including power management and analog circuitry.

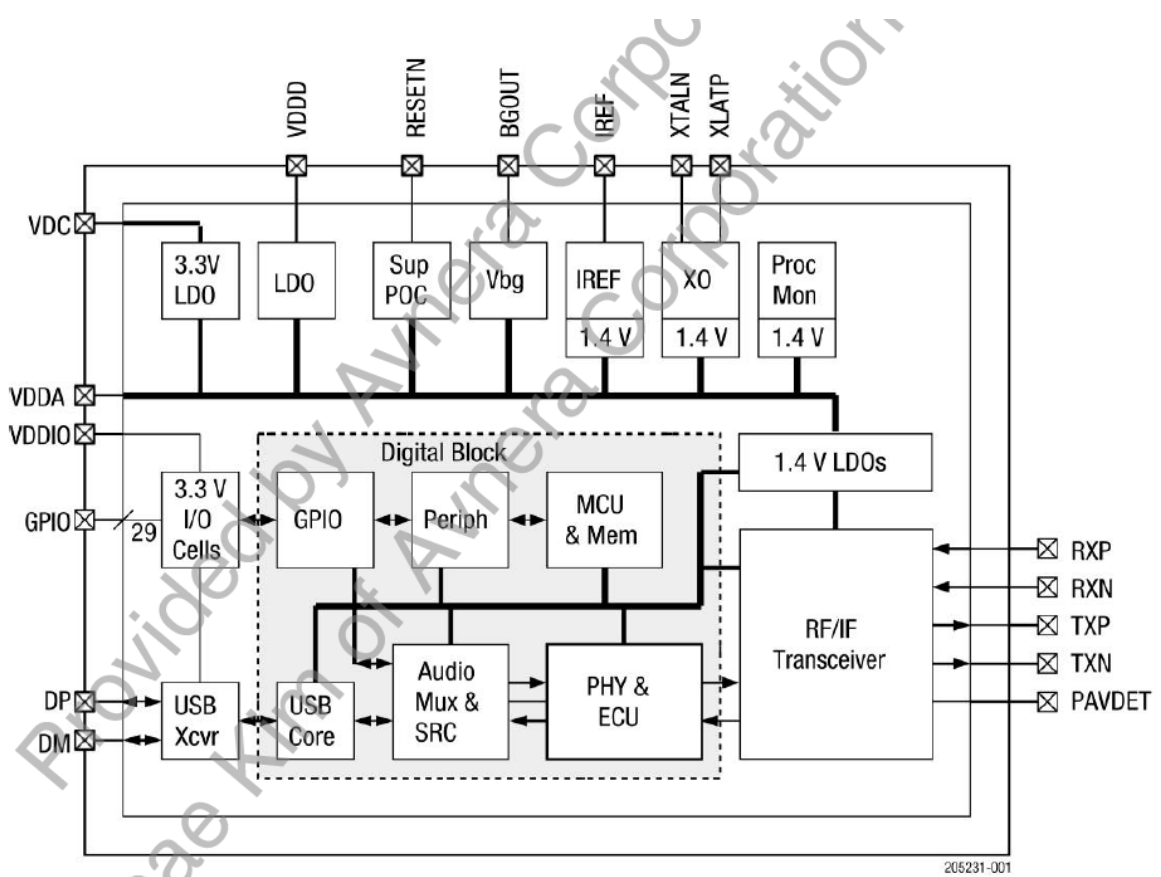

SKY76303 block diagram

The ATM511 is able to support both the lower and upper bands of 5GHz band RF spectrum, enabling worldwide coverage.

The highly integrated nature of the SKY76303 transceiver IC results in few external components being required for the ATM511 module design. 2 printed PCB antennas are used to achieve increased range, and to achieve antenna spatial diversity. The extended-range RF path consists of the antennas, associated tuning components, external power amplifier, the RF switch, and two baluns which connected to each of the RF input/output ports on the SKY76303 IC.

5GHz Wireless Audio Transceiver

REV: 01

The 16MHz crystal oscillator generates the SKY76303 IC fundamental system clock used as the basis for all RF and digital audio clocks.

The 4Mb flash memory chip is used to store the module’s application firmware. The SKY76303 is able to boot from internal ROM upon first power up, which enables programming the flash chip with the application firmware through USB. In addition, Over-the-air Firmware upgrade capability can be enabled through the application firmware.

The module can be controlled from an external host device via the I2C Slave or the SPI Slave data interfaces. The I2C master port allows the module to control other system audio devices such as a sub-woofer amplifier system without having to add another MCU to the product design.

Up to 10 additional GPIOs are available on the ATM511 module (not including I2C and I2S signals) for implementing different UI features on the target application.

The ATM511 module is available in two variations; digital input transmitter or digital output receiver.

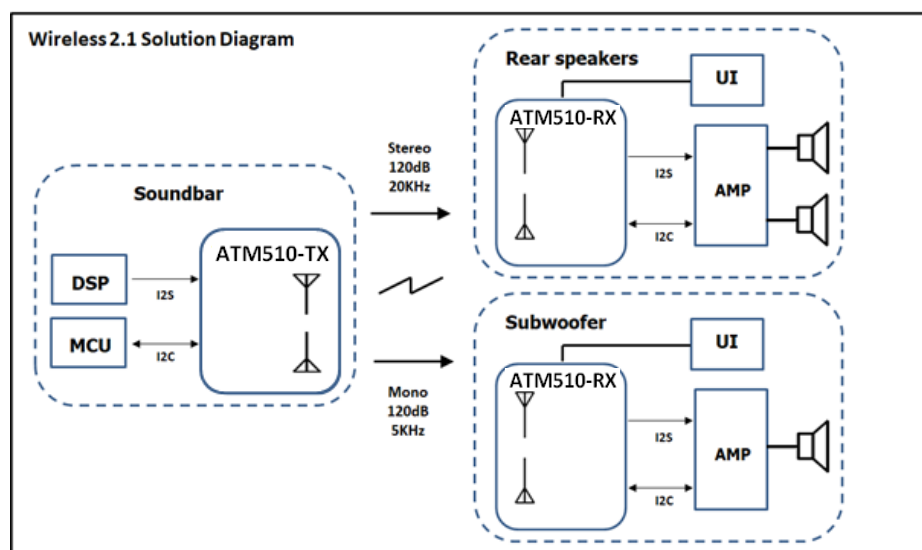
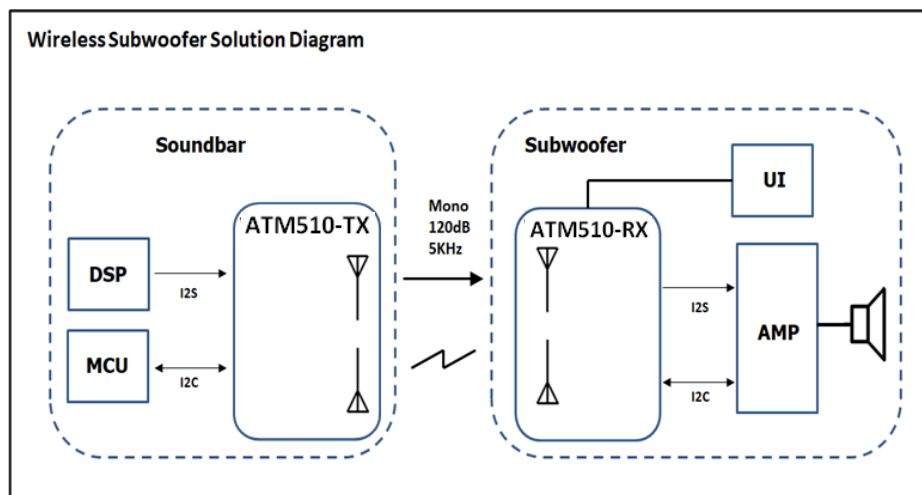

* ATM511 module has two PCB printed antenna for RX diversity. This module is not supporting for RF operation of MIMO mode. So those antenna are not used as MIMO mode.

5GHz Wireless Audio Transceiver**REV: 01**

There are two available I2S digital audio data inputs/outputs, each of these can be configured to operate as either a master or a slave – depending on the application, the I2S ports can operate simultaneously as either inputs or outputs. When configured as slaves, the I2S inputs/outputs can be independently clocked by up to two external masters. In addition, MCLK can be output from the module to provide a reference clock source to an external ADC or DAC. MCLK can also be input to the module to provide a reference clock from an external source.

The hardware for the audio input (transmit) and audio output (receive) versions of the module is identical and only the firmware loaded onto the module determines its function.

The ATM511 module is powered from +3.3V supply input.

Features

- Product Size
 - Module Size (mm): 26.0 (W) X 40.4 (L) X 3.2 (H)
 - PCB size (mm): 26.0 (W) X 40.4 (L) x 1.2 (H)
 - Shield can (mm): 24.7 (W) X 21.9 (L) X 2.0(H)
 - Antenna Type : PCB Printed Antenna
- Complete I2S to I2S audio communication system
 - 24bit I2S Audio interface and 120dB SNR Over-The-Air Link
- Frequency range : 5.15~5.25GHz, 5.725-5.875 GHz
- Low, fixed latency (typically less than 20ms)
- 3Mbps or 6Mbps OTA data rate
- Multiple OTA audio configurations
- Forward error correction coding, error detection, and audio-specific error concealment
- Auto-search/sync and dynamic channel selection
- Capability to detect and avoid wideband interferences such as 5GHz band WLAN
- Sample rate converter: Support for 32 - 96kHz input sample rates
- Dual printed PCB diversity antennas for multipath and fading migrations
- Control interfaces: I2C
- Multiple GPIOs

5. Product Information

5-1. Absolute Maximum Ratings

Absolute Maximum Ratings (AMR) are stress ratings only. AMR corresponds to the maximum value that can be applied without leading to instantaneous or very short-term unrecoverable hard failure (destructive breakdown). Stresses beyond those listed under AMR may cause permanent damage to the device.

Functional operation of the device at these or any other conditions beyond those indicated under "Recommended Operating Range" is not implied. Exposure to absolute-maximum-rated conditions for extended periods may adversely affect device reliability.

Device functional operating limits and guaranteed performance specifications are given under Electrical Characteristics at the test conditions specified.

CONDITION	MIN	MAX
+3.3V Supply Voltage Input	-0.3V	4.0V
Input Voltage Range – Digital Inputs	-0.3V	3.6V
Input Voltage Range – Analog Inputs	-0.3V	3.6V
Operating Temperature	0°C	70°C
Storage Temperature	-40°C	+85°C
Static Discharge Voltage*	TBD	TBD

Notes;

* System level ESD : IEC 61000-4-2; C = 150pF, R = 330Ω

5-2. Recommended operating Range

PARAMETER	MIN	TYP	MAX	UNIT
VDD, +3.3V Supply pin voltage	3.0	3.3	3.6	V
Ambient Temperature (TA)	0		70	°C
RESET pin hold time	10			ms
Power Supply Rise Time (to 3.0V)	0		10	ms

5-3. Electrical Characteristics – DC

Typical specifications at TA = 25°C, VDD = 3.3V

PARAMETER	CONDITION	MIN	TYP	MAX	UNIT
Current	Continuous TX (TX Module)	90	145	200	mA
	Linked status for TX		82		
	Searching for TX		46		

	Continuous RX		73		
	Linked status for RX		62		
	Searching for RX		72		
CMOS I/O Logic Levels – VDDIO 3.3V	Input Voltage Logic Low, VIL			0.6	V
	Input Voltage Logic High, VIH	VDDIO - 0.6V			
	Output Voltage Logic Low, VOL			0.3	
	Output Voltage Logic High, VOH	VDDIO - 0.3V			

5-4. Electrical Characteristics – RF TX

Operating Conditions: TA = 0°C to +70 °C, RF Freq = 5150~5250/5725-5875MHz, measured to the RF Radiated Antenna 2 ports. Typical specifications at TA = 25°C, VDD = 3.3V

PARAMETER	ANTENNA	CONDITION	MIN	TYP	MAX	UNIT
Frequency Range			5150		5875	MHz
Return loss	ANT1 & ANT2	*Low band		-10		dB
	ANT1 & ANT2	*High band		-10		
Peak Gain	ANT1 & ANT2	Low band			2.3	dBi
	ANT1 & ANT2	High band			2.6	
Average Gain	ANT1	Low band		-2.3		dBi
		High band		-2.8		
	ANT2	Low band		-2.6		
		High band		-2.6		
Efficiency	ANT1	Low band		59		%
		High band		52		
	ANT2	Low band		55		
		High band		55		
Impedance				50		Ω

5-5. Electrical Characteristics – RF RX

Operating Conditions: TA = 0°C to +70 °C, RF Freq = 5150~5250/5725-5875MHz, measured to the RF conducted 2 ports. Typical specifications at TA = 25°C, VDD = 3.3V

PARAMETER	CONDITION	MIN	TYP	MAX	UNIT
RF Channel Frequency Range	Low band	5150		5250	MHz
	High band	5725		5875	
RX Sensitivity*	SSC (Single Sub-Carrier)		-89		dBm
	DSC (Dual Sub-Carrier)		-86		
Max input signal	LNA = low gain mode, min IF gain		-5		
Out-of-band blocker level	<5150 MHz, >5850 MHz		-45		
	2400-2483.5 MHz		-20		
Spurious RF outputs	5150-5850 MHz			-65	dBm
	<5150 MHz, >5850 MHz			-65	
RF I/O Impedance	ANT0, ANT1		50		ohm

* The sensitivity been defined with BER <= 0.002.

5-6. Electrical Characteristics – RF PLL

Operating Conditions: TA = -5°C to +40 °C, RF Freq = 5150~5250/5725-5875MHz, measured to the RF conducted ports. Typical specifications at TA = 25°C, VDD = 3.3V

PARAMETER	CONDITION	MIN	TYP	MAX	UNIT
RF Channel Frequency Range	Low band	5150		5250	MHz
	High band	5725		5875	
RF Channel frequency resolution (raster)			1		MHz
Local Frequency error			5	10	ppm
Crystal Oscillator Frequency	External crystal		16		MHz
RF I/O Impedance	ANT0, ANT1		50		ohm

5-7. Electrical Characteristics – Audio C/CS

PARAMETER	CONDITION	MIN	TYP	MAX	UNIT
Audio Frequency Range	+/- 1dB	20		20,000	Hz
Audio Interface Resolution				24	bit
OTA Dynamic Range			120		dB
OTA Signal to Noise Ratio			120		dB

5-8. I2S Communication Interface Timing

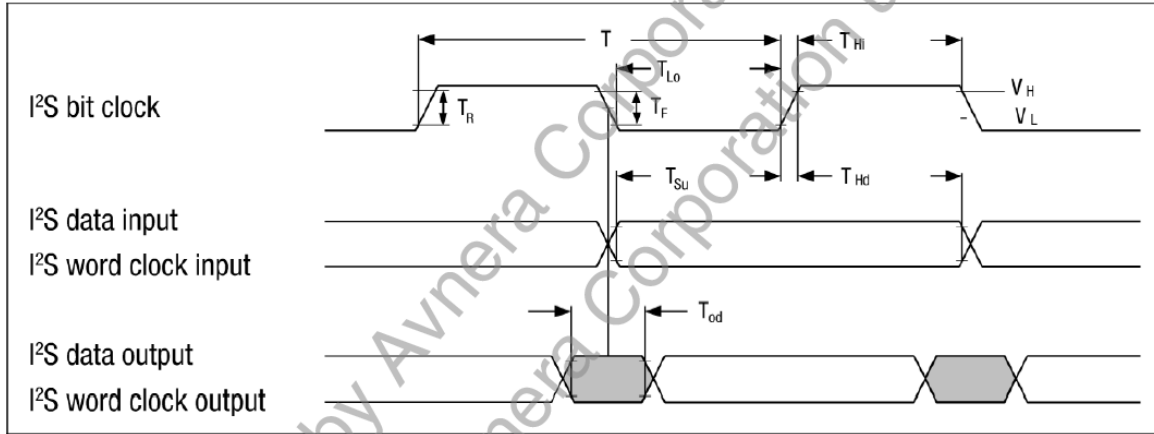

I²S Interface Timing

	PARAMETER	MIN	TYP	MAX	UNIT	Notes
V _L	Low voltage level	-0.3	0	0.4	V	
V _H	High voltage level	2.7	3.3	3.6	V	
T	Clock period		325.5		ns	1/3.072MHz
T _{Lo}	Clock low period	0.4T		0.6T		
T _{Hi}	Clock high period	0.4T		0.6T		
T _R	Rise time			50	ns	
T _F	Fall time			50	ns	
T _{Su}	Setup time	25			ns	
T _{Hd}	Hold time	25			ns	
T _{Od}	Output delay	-25		25	ns	
	Bit clocks/Word clock		64			

5-9. I2C Slave Communication Interface Timing

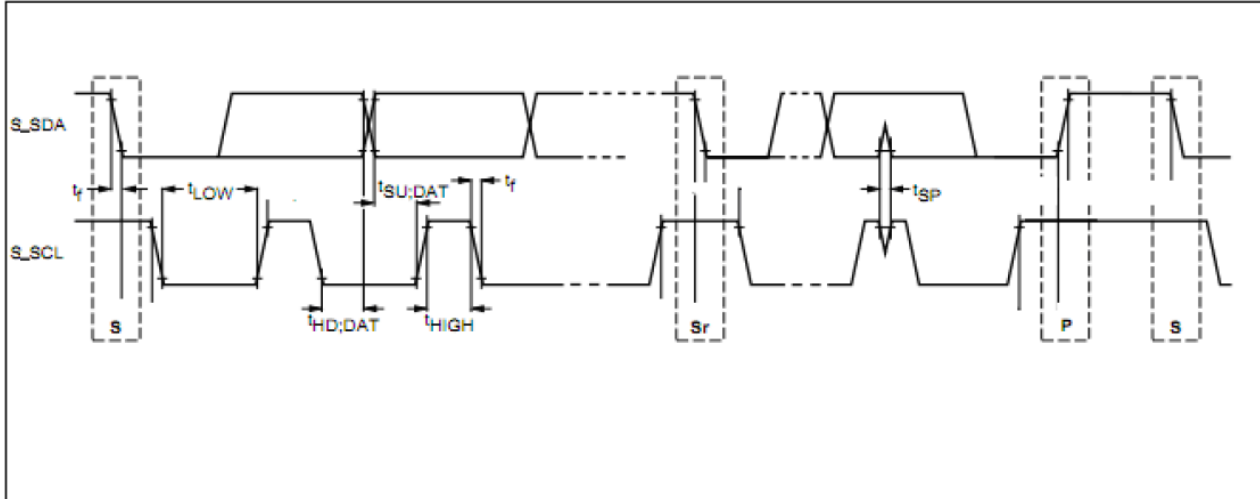

I²C Slave Interface Timing (Fast-Mode)

	Parameter	MIN	MAX	UNIT
V _{IL}	Low level input voltage	0.3	0.6	V
V _{IH}	High level input voltage	2.7	3.6	V
V _{OH}	Low level output voltage At 1mA sink current	0	0.3	V
t _{of}	Output fall time from V _{IHmin} to V _{ILmax} with a bus capacitance from 10pF to 400pF	0	250	ns
t _{SP}	Pulse width of spike which must be suppressed by the input filter	0	50	ns
f _{SCL}	S_SCL clock frequency	0	400	KHz
t _{LOW}	Low period of the S_SCL clock	1.3		us
T _{HIGH}	High period of the S-SCL clock	0.6		us
t _{HD;DAT}	Data hold time	100		ns
T _{SU;DAT}	Data set-up time	100		ns

6. I/O Connector Pin Description

No	Pin Name	I/O	ATM511-TX Pin Description	ATM511-RX Pin Description
1	GPIO2 /S_SSB	I/O	GPIO or SPI slave chip select	GPIO or SPI slave chip select
2	GPIO3 /S_SCLK	I/O	GPIO or SPI slave serial clock	GPIO or SPI slave serial clock
3	GPIO4 / I2CS_SDA/S_MOSI	I/O	GPIO, I2C slave serial data or SPI slave data In	GPIO, I2C slave serial data or SPI slave data In
4	GPIO5 / I2CS_SCL/S_MISO	I/O	GPIO, I2C slave serial clock or SPI slave data out	GPIO, I2C slave serial clock or SPI slave data out
5	GPIO16 / I2CM_SDA	I/O	GPIO or I2C master serial data	GPIO or I2C master serial data
6	GPIO17 / I2CM_SCL	I/O	GPIO or I2C master serial clock	GPIO or I2C master serial clock
7	GPIO20 /LINK_LED	I/O	GPIO or Link_LED output	GPIO or Link_LED output
8	GPIO21/ PAIR	I/O	GPIO or Input from PAIR Button	GPIO or Input from PAIR Button
9	GPIO18 /BCK1	I/O	GPIO or I2S port1 bit clock	GPIO or I2S port1 bit clock
10	GPIO19 / WCLK1	I/O	GPIO or I2S port1 word clock	GPIO or I2S port1 word clock
11	GPIO10 /MCLK	I/O	GPIO or Master clock out	GPIO or Master clock out
12	GND	GND	GND	GND
13	GPIO11 / BCK0	I/O	GPIO or I2S port0 bit clock	GPIO or I2S port0 bit clock
14	GPIO12 /WCLK0	I/O	GPIO or I2S port0 word clock	GPIO or I2S port0 word clock
15	GPIO13 /ADAT0	I/O	GPIO or I2S port0 audio data	GPIO or I2S port0 audio data
16	GPIO14 / ADAT1	I/O	GPIO or I2S port1 audio data	GPIO or I2S port1 audio data
17	GPIO15 / ADAT2/CEN	I/O	GPIO, I2S port2 audio data or Chip enable	GPIO, I2S port2 audio data or Chip enable
18	GPIO22 / D+	I/O	GPIO or USB data plus	GPIO or USB data plus
19	GPIO23 / D-	I/O	GPIO or USB data minus	GPIO or USB data minus
20	GPIO24	I/O	GPIO	GPIO
21	RESETN_EXT	I	Reset signal active low	Reset signal active low
22	GND	GND	GND	GND
23	VDD	Supply	+3.3V input supply voltage	+3.3V input supply voltage
24	VDD	Supply	+3.3V input supply voltage	+3.3V input supply voltage

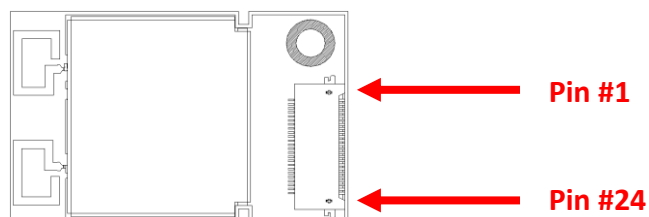

7. Mechanical Specifications

7-1. Module dimension

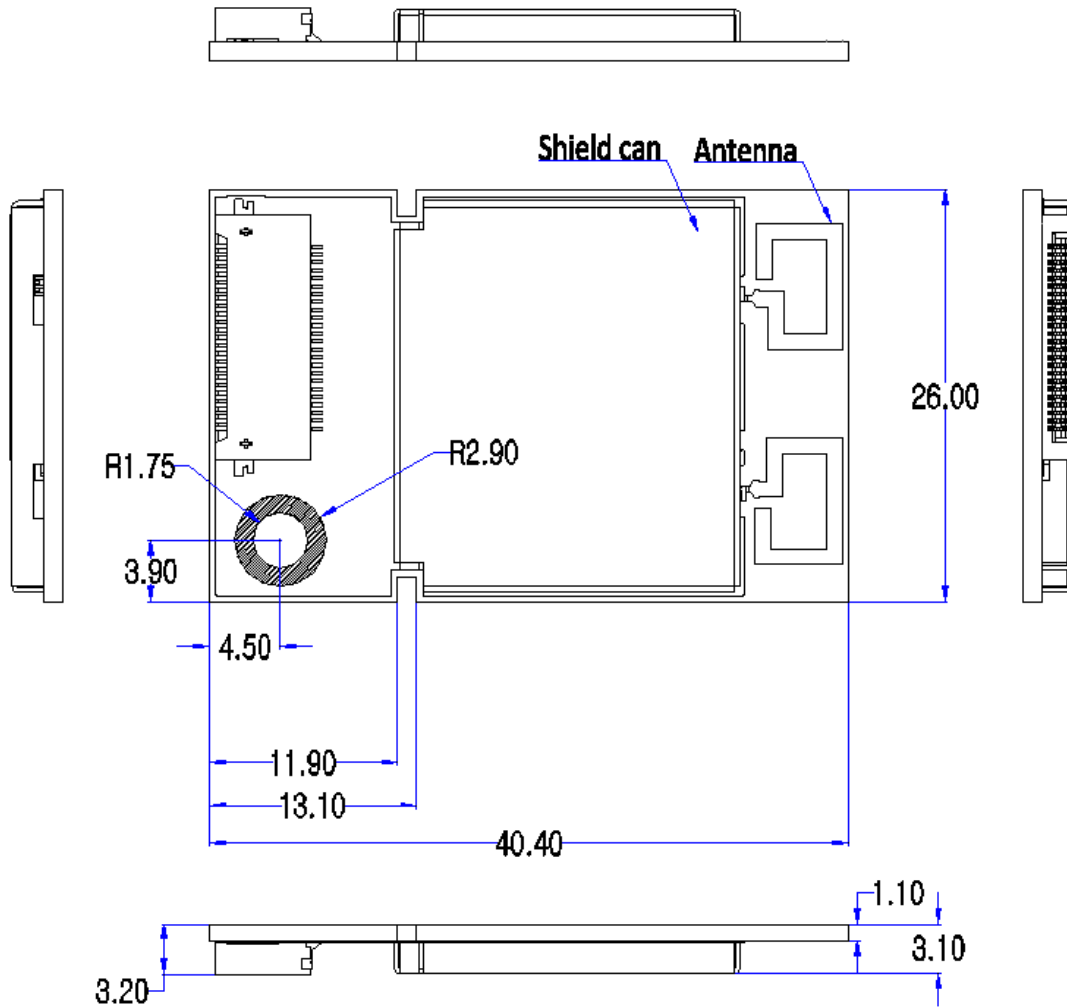

7-2. Antenna dimension

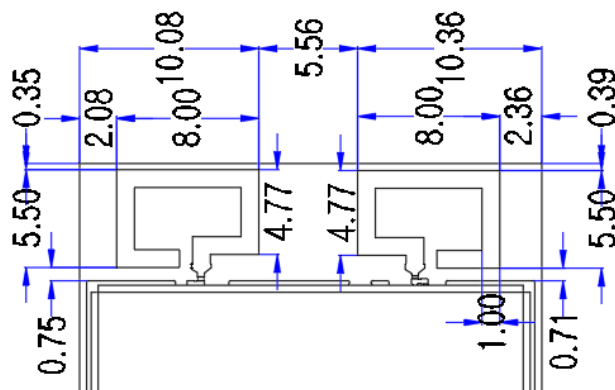

8. Label Specification

Notice] The label specifications described as below are an example. The Part number, firmware version and color will be changed by customer

8-1. Label Information Descriptions

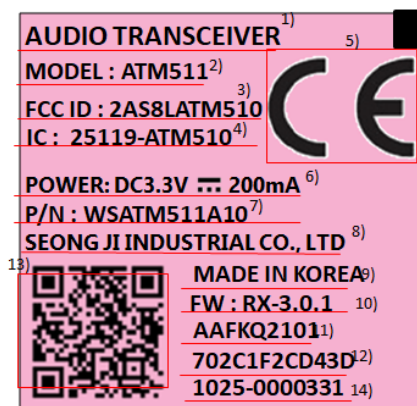
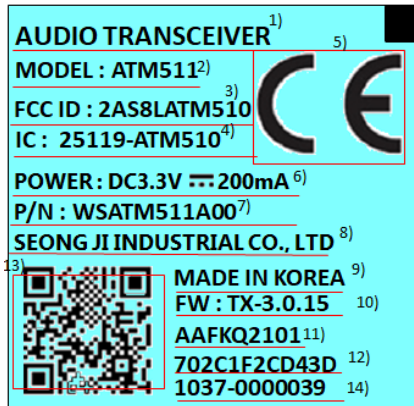

No.	Information Description
1	Product Application
2	Model Name
3	FCC Certification
4	IC(ISED) Certification ID
5	CE Mark
6	Input Rating Voltage
7	Part Number
8	ManuFacter
9	ManuFactering Country
10	Firmware Version
11	Product Lot Number
12	Product serial Number
13	QR (S/N, Product Code)
14	Customer PN

8-2. Label Size and attach

Size: 22 X 21.5 [mm]
 color : SKYBLUE

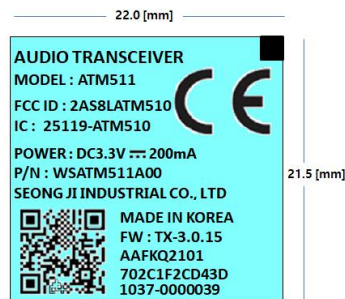

Size: 22 X 21.5 [mm]
 color : Pink

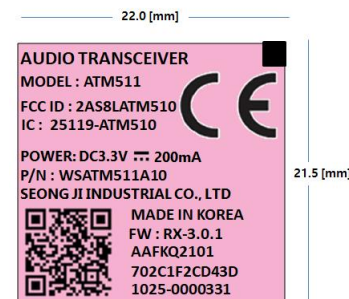

9. Certificate Statement

FCC & IC Statement

This WIRELESS AUDIO TRANSCEIVER has been granted modular approval for mobile applications. OEM integrators for host products may use the module in their final products without additional FCC / IC (Industry Canada) certification if they meet the following conditions. Otherwise, additional FCC / IC approvals must be obtained.

- The host product with the module installed must be evaluated for simultaneous transmission requirements.
- The user's manual for the host product must clearly indicate the operating requirements and conditions that must be observed to ensure compliance with current FCC / IC RF exposure guidelines.
- To comply with FCC / IC regulations limiting both maximum RF output power and human exposure to RF radiation, use this module only with the included onboard antenna.
- A label must be affixed to the outside of the host product with the following statements:

Product Name : ATM511

Contains FCC ID: **2AS8LATM510**

Contains IC: **25119-ATM510**

The final host / module combination may also need to be evaluated against the FCC Part 15B criteria for unintentional radiators in order to be properly authorized for operation as a Part 15 digital device.

This equipment has been tested and found to comply within the limits for a Class B digital device, pursuant to part 15 of the FCC Rules. These limits are designed to provide reasonable protection against harmful interference in a residential installation.

This equipment generates, uses, and can radiate radio frequency energy and, if not installed and used in accordance with the instructions, may cause harmful interference to radio communications. However, there is no guarantee that interference will not occur in a particular installation. If this equipment does cause harmful interference to radio or television reception, which can be determined by turning the equipment off and on, the user is encouraged to try to correct the interference by one or more of the following measures:

- Reorient or relocate the receiving antenna
- Increase the separation between the equipment and receiver
- Connect the equipment into an outlet on a different circuit from that to which the receiver is connected
- Consult the dealer or an experienced radio/TV technician for help.

Device Classifications

Since host devices vary widely with design features and configurations module integrators shall follow the guidelines below regarding device classification and simultaneous transmission, and seek guidance from their preferred regulatory test lab to determine how regulatory guidelines will impact the device compliance. Proactive management of the regulatory process will minimize unexpected schedule delays and costs due to unplanned testing activities.

The module integrator must determine the minimum distance required between their host device and the user's body. The FCC provides device classification definitions to assist in making the correct determination. Note that these classifications are guidelines only; strict adherence to a device classification may not satisfy the regulatory requirement as near-body device design details may vary widely. Your preferred test lab will be able to assist in determining the appropriate device category for your host product and if a KDB or PBA must be submitted to the FCC.

Note, the module you are using has been granted modular approval for mobile applications. Portable applications may require further RF exposure (SAR) evaluations. It is also likely that the host / module combination will need to undergo testing for FCC Part 15 regardless of the device classification. Your preferred test lab will be able to assist in determining the exact tests which are required on the host / module combination.

FCC Definitions

Portable: (§2.1093) — A portable device is defined as a transmitting device designed to be used so that the radiating structure(s) of the device is / are within 20 centimeters of the body of the user.

Mobile: (§2.1091) (b) — A mobile device is defined as a transmitting device designed to be used in other than fixed locations and to generally be used in such a way that a separation distance of at least 20 centimeters is normally maintained between the transmitter's radiating structure(s) and the body of the user or nearby persons. Per §2.1091d(d)(4) In some cases (for example, modular or desktop transmitters), the potential conditions of use of a device may not allow easy classification of that device as either Mobile or Portable. In these cases, applicants are responsible for determining minimum distances for compliance for the intended use and installation of the device based on evaluation of either specific absorption rate (SAR), field strength, or power density, whichever is most appropriate.

Simultaneous Transmission Evaluation

This module has **not** been evaluated or approved for simultaneous transmission as it is impossible to determine the exact multi-transmission scenario that a host manufacturer may choose. Any simultaneous transmission condition established through module integration into a host product **must** be evaluated per the requirements in KDB447498D01(8) and KDB616217D01,D03 (for laptop, notebook, netbook, and tablet applications).

These requirements include, but are not limited to:

- Transmitters and modules certified for mobile or portable exposure conditions can be incorporated in mobile host devices without further testing or certification when:

- The closest separation among all simultaneous transmitting antennas is >20 cm,

Or

- Antenna separation distance and MPE compliance requirements for **ALL** simultaneous transmitting antennas have been specified in the application filing of at least one of the certified transmitters within the host device.

In addition, when transmitters certified for portable use are incorporated in a mobile host device, the antenna(s) must be >5 cm from all other simultaneous transmitting antennas.

- All antennas in the final product must be at least 20 cm from users and nearby persons.

OEM Instruction Manual Content

Consistent with §2.909(a), the following text must be included within the user's manual or operator instruction guide for the final commercial product (*OEM-specific content is displayed in italics.*)

Operating Requirements and Conditions:

The design of *ATM511* complies with U.S. Federal Communications Commission (FCC) guidelines respecting safety levels of radio frequency (RF) exposure for Mobile devices.

Note: In the case where the Host / Module combination has been re-certified the FCCID shall appear in the product manual as follows:

FCCID: **2AS8LATM510**

Mobile Device RF Exposure Statement (If Applicable):

RF Exposure - This device is only authorized for use in a mobile application. At least 20 cm of separation distance between the transmitting antenna device and the user's body must be maintained at all times.

Caution Statement for Modifications:

Caution: Any changes or modifications to the equipment not expressly approved by the party responsible for compliance could void user's authority to operate the equipment.

FCC Part 15 Statement (Only Include if FCC Part 15 is Required on the End Product):

Note: This equipment has been tested and found to comply with the limits for a *Class B* digital device, pursuant to Part 15 of the FCC Rules. (*OEM must follow Part 15 guidelines (§15.105 and §15.19) to determine additional statements required in this section for their device class*)

Note 2 : This device complies with part 15 of the FCC Rules.

Operation is subject to the following two conditions.

- 1) This device may not cause harmful interference, and
 - 2) This device must accept any interference, including interference that may cause undesired operation of the device.
- a. That module is limited to OEM installation ONLY.
 - b. That OEM integrators are responsible for ensuring that the end-user has no manual instructions to remove or install module.
 - c. That module is limited to installation in mobile or fixed applications, according to Part 2.1091(b).
 - d. That separate approval is required for all other operating configurations, including portable configurations with respect to Part 2.1093 and different antenna configurations.
 - e. That grantee shall provide guidance to the host manufacturer for compliance with Part 15 subpart B requirements.

Information

Le présent appareil est conforme aux CNR d'Industrie Canada applicable aux appareils radio exempts de licence.

L'exploitation est autorisée aux deux conditions suivantes :

- (1) l'appareil ne doit pas produire de brouillage, et
- (2) l'utilisateur de l'appareil doit accepter tout brouillage radioélectrique subi, même si le brouillage est susceptible d'en compromettre le fonctionnement.

Cet équipement est conforme aux limites d'exposition aux rayonnements énoncées pour un environnement non contrôlé et respecte les règles des radioélectriques (RF) de la FCC lignes directrices d'exposition et d'exposition aux fréquences radioélectriques (RF) CNR-102 de l'IC. Cet équipement émet une énergie RF très faible qui est considérée conforme sans évaluation du débit d'absorption spécifique (DAS).

CE Statement

Hereby, SEONG JI INDUSTRIAL CO., LTD declares that the radio equipment type AUDIO TRANSCEIVER is in compliance with Directive 2014/53/EU. The full text of the EU declaration of conformity is available at the providing datasheet or approval sheet.

The antenna(s) must be installed such that a minimum separation distance of at least 20 cm is maintained between the radiator (antenna) and all persons at all times. This device must not be collocated or operating in conjunction with any other antenna or transmitter.