

线圈规格书

客 户:
CUSTOMER:

客 户 料 号:
CUST P/N:

Y.009.0025

料 号:
FINE P/N:

G511-6.3UH±10% 单线圈 0.08*80*10TS

产 品 型 号:
DESC:

Φ 42.5MMX42.5MMX1.0MM

日 期:
DATE:

2021-7-20

版 本:
Version:

A.0

版本變更履歷

SPECIFICATION

產品型號:	Φ 20.5x43-6.3uH-0.08x105-6mm-50C	版本 Rev: A.0	客戶 CUST:	XXX
			客戶料号 CUST P/N:	Y.009.0025

一、尺寸 DIMENSION:(mm)

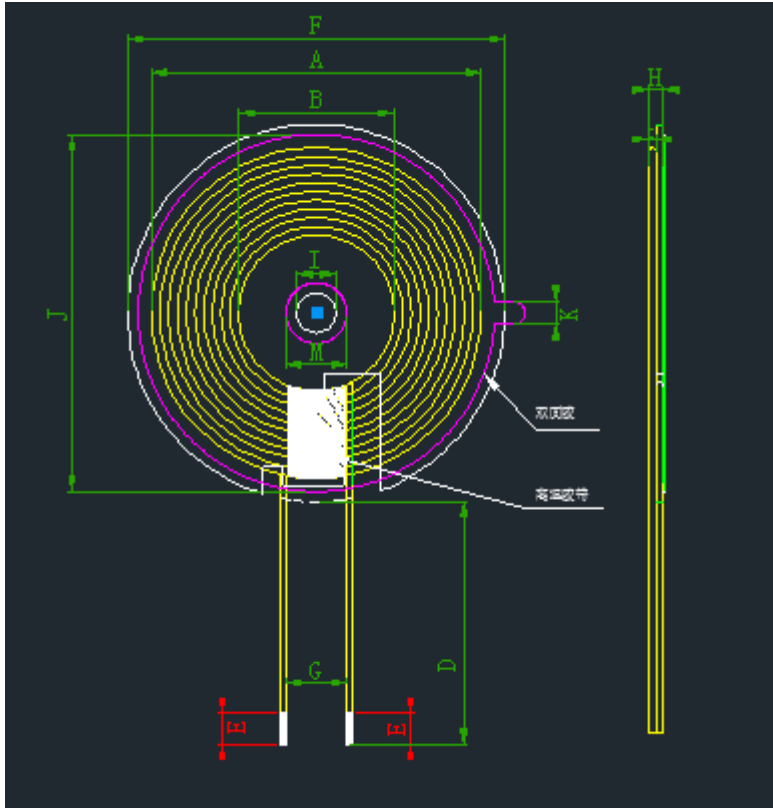

A	40.5 ± 1.0
B	20.5 ± 0.5
C	Max
D	22Max
E	5 ± 2 MM
F	42.5Max
G	5MMref
H	2.2 Max
I	4.3 ref
M	
J	
K	

注:

- 1.交叉出线;
- 2.出线位置缠 8mm(ref)宽度高温胶纸 1-2Ts;
- 3.线圈贴圆形硬磁片带槽, 磁片尺寸 42.5 ± 1mm,内孔 4.3mm,厚度为 1.0 ± 0.2mm
- 4.双开槽。

二、原理图 SCHEMATIC DIAGRAM:

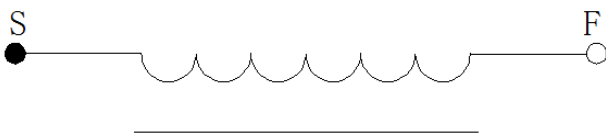

Shenzhen Be-Comfortable Technology Co. Ltd
 West, 4th Floor, Building B, Shuangjinhui Industrial City, Yonghe Road, Heping Community, Fuyong Street, Bao'an District, Shenzhen

三、绕线参数 Winding Specification:

NO.	端子 TERMINAL		线径 WIRE	圈数 Turns	绕线方向 Winding Direction
1	S	F	漆包线 0.08*80P	10Ts	CCW

四、电气特性 ELECTRICAL CHARACTERISTICS:

温度 TEMPERATURE:25±10℃, 湿度 RELATIVE HUMIDITY:65±20%

序号 NO.	项目 ITEM	端子 TERMINAL	标准 SPECIFICATION	测试条件 TEST FREQUENCY	测试仪器 TEST EQUIPMENTS
1	IND.	S-F	3.8uH ±20%	100KHz/1.0V	LCZ METER 1062B
2	IND.	S-F	6.3uH ±10%	100KHz/1.0V	LCZ METER 1062B
3	DCR	S-F	≤50mΩ		LCZ METER 502B

拟制/日期 PREPARED BY/DATE

审核/日期 CHECKED BY/DATE

