

# Antenna Report

## 1. Tested Equipment

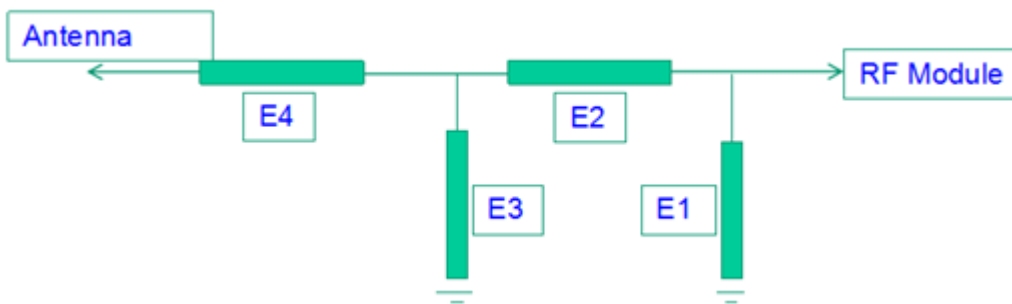

## 2. Circuit



## 3. Antenna Test

