

Acknowledgment

ROHS

CUSTOMER: Shenzhen Future Charger Technology Co. Ltd.

CUSTOMER P/N:0001.DZ.0010.0110

DESCRIPTION :

DATE:2022-8-29

SPECIFICATION: Watch coil soft magnetic-6.7uH

REV. NO. :A0

Acknowledgement, signature and seal for HRSW ELECTRONICS CO.,LTD

department	confirm/date	examine/date	approval/date	(Seal of the Company)
Quality	董晚红 2022-8-29	吕惠 2022-8-29	韦函满 2022-8-29	
engineering	何伟华 2022-8-29	韦立红 2022-8-29	韦立红 2022-8-29	

remarks:

Acknowledgement, signature and seal for Shenzhen Future Charger Technology Co. Ltd.

departme	confirm/date	examine/date	approval/date	(Seal of the Company)
R&D				
purchase				
Quality				

remarks:

深圳市鸿日昇威科技有限公司

HRSW ELECTRONICS CO.,LTD

ADD: Floor 2, Building 1, No. 48 Huanguan Middle Road, Guanlan, Longhua New District, Shenzhen

TEL: +86-755-23461055 FAX: +86-0755-28015170

SPECIFICATION FOR APPROVAL

1. MECHANICAL DIMENSION (UNIT:mm)

2. SCHEMATICS:

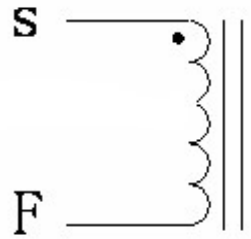
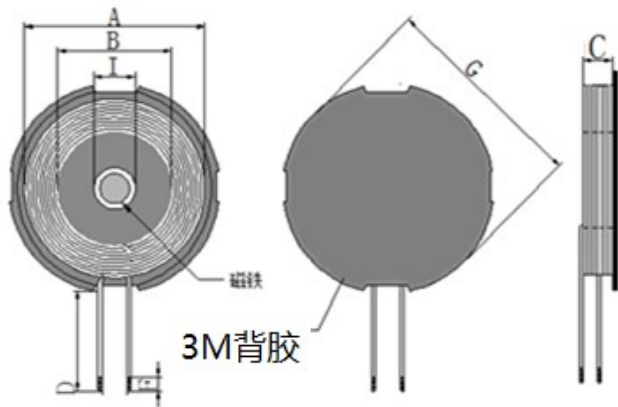

A	B	C	D	F	G				
20±2	14±1	2.7±0.5	15±2	4±2	25±2				

3. WINDING:

STEP	START-FINISH	WIRE TYPE	TURNS	TAPE	REMARK
N1	S-F	□0.08*24mm 2UEW	12TS (Ref)		

4. ELECTRICAL SPECIFICATION:

ITEM	L	DCR	IDC	Q值	HI-POT
TEST	S-F	S-F	S-F		
CON	100KHz, 0.25V	AT 25°C	AT 25°C		
SPEC	6.7uH±10%	40mΩ (Max)	3A		

5. BILF OF MATERIAL:

NO.	ITEM	MATERIAL SPECIFICATION	MANUFACTURER	SGS NO.
1	Magnetic core	UG25 soft magnetic	NANJINGJINNINGCO,LTD	
2	magnetic	N52 7.8*2.2	NANJINGJINNINGCO,LTD	
3	Copper wire	□0.08mm*24 2UEW	TAIYI CO.,LTD	
4	Gum backing	23 Single side adhesive	HONGBAOJEICO,LTD	
5	Solder Bar	Solder Bar	QIANDAO CO.,LTD	
6	glue	9999	CUDAK CO.,LTD	

HRSW ELECTRONICS CO., LTD	PART NO	
	TITLE	Watch coil soft magnetic-6.7uH
DRAWN BY	CHECKED BY	APPROVED BY
谢超	何伟华	韦立红

SPECIFICATION FOR APPROVAL

6. SAMPLE TEST DATA

6.1 DIMENSION TEST (UNIT: mm)

TEST ITEM	A	B	C	D	F	G		
	20±2	14±1	2.7±0.5	15±2	4±2	24±2		
1	20.08	13.95	2.74	15.2	3.25	24.30		
2	21.035	14.02	2.71	14.9	3.34	24.60		
3	21.04	13.98	2.68	15	4.02	24.80		
4	21.03	14	2.67	15.02	3.98	25.00		
5	20.98	14.05	2.69	14.89	3.89	25.37		
MAX	21.04	14.05	2.74	15.20	4.02	25.37		
MIN	20.08	13.95	2.67	14.89	3.25	24.30		
AVERAGE	20.76	14.00	2.70	15.01	3.68	24.82		

6.2 ELECTRICAL TEST

TEST ITEM	L		DCR	IDC		Q	HI-POT	
	S-F		S-F					
TEST COND	100KHz/0.25v		AT 25°C					
SPEC	6.7uH ±10%		40mΩ (Max)					
1	6.71		21.00					
2	6.98		20.00					
3	6.72		21.50					
4	6.70		20.30					
5	6.98		20.40					
6								
MAX	6.98		21.50					
MIN	6.70		20.00					
AVERAGE	6.84		20.75					

HRSW ELECTRONICS CO., LTD

PART NO

TITLE

Watch coil soft
magneti-6.7uH

DRAWN BY

CHECKED BY

APPROVED BY

谢超

何伟华

韦立红

