



FCC TEST REPORT

FCC ID:2AS6X-HM37

Report Number	ZKT-2210187709E
Date of Test.....	Oct. 18, 2022 to Oct. 25, 2022
Date of issue.....	Oct. 25, 2022
Total number of pages.....	22
Test Result	PASS
Testing Laboratory	Shenzhen ZKT Technology Co., Ltd.
Address	1/F, No. 101, Building B, No. 6, Tangwei Community Industrial Avenue, Fuhai Street, Bao'an District, Shenzhen, China
Applicant's name	Shenzhen Future Charger Technology Co., LTD.
Address	Yongfengtian Industrial Park , fenghuang third industrial zone,Fuyong town,Baoan District,Shenzhen, China
Manufacturer's name	Shenzhen Future Charger Technology Co., LTD.
Address	Yongfengtian Industrial Park , fenghuang third industrial zone,Fuyong town,Baoan District,Shenzhen, China
Test specification:	
Standard.....	FCC CFR Title 47 Part 15 Subpart C
Test procedure.....	/
Non-standard test method	N/A
Test Report Form No	TRF-EL-107_V0
Test Report Form(s) Originator	ZKT Testing
Master TRF	Dated: 2020-01-06
<p>This device described above has been tested by ZKT, and the test results show that the equipment under test (EUT) is in compliance with the FCC requirements. And it is applicable only to the tested sample identified in the report.</p> <p>This report shall not be reproduced except in full, without the written approval of ZKT, this document may be altered or revised by ZKT, personal only, and shall be noted in the revision of the document.</p>	
Product name	3-in-1 Magnetic Wireless Charging Station
Trademark	N/A
Model/Type reference.....	HM37 HM37Pro, EM37, EM37Pro
Ratings.....	Input: DC 9V/3A, 5V/3A Output: Mobile phone: 15W (Max) Earphone: 5W (Max) Watch: 3W (Max)



Testing procedure and testing location:

Testing Laboratory.....: **Shenzhen ZKT Technology Co., Ltd.**

Address.....: 1/F, No. 101, Building B, No. 6, Tangwei Community Industrial Avenue, Fuhai Street, Bao'an District, Shenzhen, China

Tested by (name + signature).....: Tom Zou

Tom Zou

Reviewer (name + signature).....: Jackson Fang

Jackson Fang

Approved (name + signature).....: Lake Xie





TABLE OF CONTENTS

1. VERSION	4
2. TEST SUMMARY	5
2.1 TEST FACILITY	6
2.2 MEASUREMENT UNCERTAINTY	6
3. GENERAL INFORMATION	7
3.1 GENERAL DESCRIPTION OF EUT	7
3.2 Test mode	7
3.3 Block Diagram of EUT Configuration	8
3.4 Test Conditions	8
3.5 Description Of Support Units (Conducted Mode)	8
3.6 EQUIPMENTS LIST FOR ALL TEST ITEMS	9
4. CONDUCTED EMISSION TEST	10
4.1 CONDUCTED EMISSION MEASUREMENT	10
4.1.1 POWER LINE CONDUCTED EMISSION Limits	10
4.1.2 TEST PROCEDURE	10
4.1.3 DEVIATION FROM TEST STANDARD	10
4.1.4 TEST SETUP	11
4.1.5 EUT OPERATING CONDITIONS	11
4.1.6 Test Result	11
5. RADIATED EMISSION MEASUREMENT	14
5.1 Radiated Emission Limits	14
5.2 Anechoic Chamber Test Setup Diagram	15
5.3 Test Procedure	15
5.4 DEVIATION FROM TEST STANDARD	15
5.5 Test Result	16
6. BANDWIDTH TEST	19
7. ANTENNA REQUIREMENT	21
8. TEST SETUP PHOTO	22
9. EUT CONSTRUCTIONAL DETAILS	22



1. VERSION

Report No.	Version	Description	Approved
ZKT-2210187709E	Rev.01	Initial issue of report	Oct. 25 2022



2. TEST SUMMARY

Test Item	Section in CFR 47	Result
Antenna requirement	15.203	Pass
AC Power Line Conducted Emission	15.207	Pass
Spurious Emission	15.209(a)(f)	Pass
20dB Bandwidth	15.215	Pass

NOTE:

(1) "N/A" denotes test is not applicable in this Test Report



2.1 TEST FACILITY

Shenzhen ZKT Technology Co., Ltd.
Add. : 1/F, No. 101, Building B, No. 6, Tangwei Community Industrial Avenue, Fuhai Street,
Bao'an District, Shenzhen, China

FCC Test Firm Registration Number: 692225
Designation Number: CN1299
IC Registered No.: 27033

2.2 MEASUREMENT UNCERTAINTY

The reported uncertainty of measurement $y \pm U$, where expanded uncertainty U is based on a standard uncertainty multiplied by a coverage factor of $k=2$, providing a level of confidence of approximately 95 %.

No.	Item	Uncertainty
1	3m chamber Radiated spurious emission(9KHz-30MHz)	U=4.5dB
2	3m chamber Radiated spurious emission(30MHz-1GHz)	U=4.8dB
3	3m chamber Radiated spurious emission(1GHz-6GHz)	U=4.9dB
4	3m chamber Radiated spurious emission(6GHz-40GHz)	U=5.0dB
5	Conducted disturbance	U=3.2dB
6	RF Band Edge	U=1.68dB
7	RF power conducted	U=1.86dB
8	RF conducted Spurious Emission	U=2.2dB
9	RF Occupied Bandwidth	U=1.8dB
10	RF Power Spectral Density	U=1.75dB
11	humidity uncertainty	U=5.3%
12	Temperature uncertainty	U=0.59°C



3. GENERAL INFORMATION

3.1 GENERAL DESCRIPTION OF EUT

Product Name:	3-in-1 Magnetic Wireless Charging Station
Model No.:	HM37
Model Difference:	Only the model name is different.
Serial No.:	HM37Pro, EM37, EM37Pro
Hardware version:	V1.1
Software version:	V1.0
Operation Frequency:	115KHz ~ 205KHz
Modulation type:	MSK
Antenna Type:	Inductive loop coil Antenna
Antenna gain:	0dBi
Power supply:	Input: DC 9V/3A, 5V/3A Output: Mobile phone: 15W (Max) Earphone: 5W (Max) Watch: 3W (Max)
Test Description:	Mobile phone and Earphone and Watch Battery>98%, =50%and <1% are tested, and the worst is <1%.

3.2 Test mode

Test Modes:		
Mode 1	AC/DC Adapter (9V/3A) + EUT + Mobile phone	
Mode 2	AC/DC Adapter (9V/3A) + EUT + Earphone	
Mode 3	AC/DC Adapter (9V/3A) + EUT + Watch	
Mode 4	AC/DC Adapter (9V/3A) + EUT + Mobile phone + Earphone	
Mode 5	AC/DC Adapter (9V/3A) + EUT + Mobile phone + Watch	
Mode 6	AC/DC Adapter (9V/3A) + EUT + Mobile phone + Earphone + Watch	Record
Mode 7	AC/DC Adapter (5V/3A) + EUT + Mobile phone	
Mode 8	AC/DC Adapter (5V/3A) + EUT + Earphone	
Mode 8	AC/DC Adapter (5V/3A) + EUT + Watch	
Mode 10	AC/DC Adapter (5V/3A) + EUT + Mobile phone + Earphone	
Mode 11	AC/DC Adapter (5V/3A) + EUT + Mobile phone + Watch	
Mode 12	AC/DC Adapter (5V/3A) + EUT + Mobile phone + Earphone + Watch	
N/A		



3.3 Block Diagram of EUT Configuration

Conducted Emission

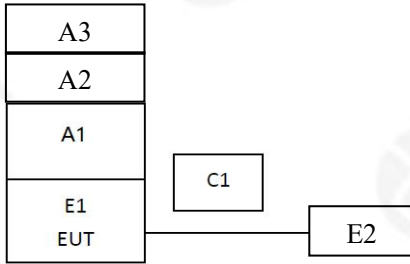

Radiated Emission

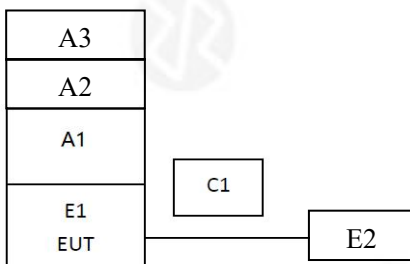

3.4 Test Conditions

Temperature: 23~26°C

Relative Humidity: 54~63 %

3.5 Description Of Support Units (Conducted Mode)

The EUT has been tested as an independent unit together with other necessary accessories or support units. The following support units or accessories were used to form a representative test configuration during the tests.

Item	Equipment	Mfr/Brand	Model/Type No.	Series No.	Note
E1	3-in-1 Magnetic Wireless Charging Station	N/A	HM37	HM37Pro, EM37, EM37Pro	EUT
E2	AC/DC Adapter	HUAWEI	ZKT-00	N/A	Auxiliary
A1	Mobile phone	HUAWEI	ZKT-01	N/A	Auxiliary
A2	Earphone	HUAWEI	ZKT-02	N/A	Auxiliary
A3	Watch	HUAWEI	ZKT-03	N/A	Auxiliary

Item	Shielded Type	Ferrite Core	Length	Note
C1	NO	NO	1.0M	DC cable unshielded

Note:

- (1) The support equipment was authorized by Declaration of Confirmation.
- (2) For detachable type I/O cable should be specified the length in cm in 『Length』 column.
- (3) “YES” is means “shielded” “with core”; “NO” is means “unshielded” “without core”.



3.6 EQUIPMENTS LIST FOR ALL TEST ITEMS

Radiation Test equipment

Item	Equipment	Manufacturer	Type No.	Serial No.	Last calibration	Calibrated until
1	Spectrum Analyzer (9kHz-26.5GHz)	KEYSIGHT	9020A	MY55370835	Oct. 18, 2022	Oct. 17, 2023
2	Spectrum Analyzer (1GHz-40GHz)	R&S	FSQ	100363	Oct. 17, 2022	Oct. 16, 2023
3	EMI Test Receiver (9kHz-7GHz)	R&S	ESCI7	101169	Oct. 18, 2022	Oct. 17, 2023
4	Bilog Antenna (30MHz-1500MHz)	Schwarzbeck	VULB9168	N/A	Oct. 17, 2022	Oct. 16, 2023
5	Horn Antenna (1GHz-18GHz)	Agilent	AH-118	071145	Oct. 17, 2022	Oct. 16, 2023
6	Loop Antenna	TESEQ	HLA6121	58357	Oct. 17, 2022	Oct. 16, 2023
7	Amplifier (30-1000MHz)	EM Electronics	EM330 Amplifier	060747	Oct. 18, 2022	Oct. 17, 2023
8	Amplifier (1GHz-26.5GHz)	Agilent	8449B	3008A00315	Oct. 18, 2022	Oct. 17, 2023
9	RF cables1 (9kHz-30MHz)	N/A	9kHz-30MHz	N/A	Oct. 18, 2022	Oct. 17, 2023
10	RF cables2 (30MHz-1GHz)	N/A	30MHz-1GHz	N/A	Oct. 18, 2022	Oct. 17, 2023
11	RF cables3 (1GHz-40GHz)	N/A	1GHz-40GHz	N/A	Oct. 18, 2022	Oct. 17, 2023
12	ESG Signal Generator	Agilent	E4421B	N/A	Oct. 22, 2022	Oct. 21, 2023
13	Signal Generator	Agilent	N5182A	N/A	Oct. 22, 2022	Oct. 21, 2023
14	Magnetic Field Probe Tester	Narda	ELT-400	0-0344	Oct. 17, 2022	Oct. 16, 2023
15	MWRF Power Meter Test system	MW	MW100-RPCB	N/A	Oct. 22, 2022	Oct. 21, 2023
16	D.C. Power Supply	LongWei	TPR-6405D	N/A	\	\
17	EMC Software	Frad	EZ-EMC	Ver.EMC-CON 3A1.1	\	\
18	RF Software	MW	MTS8310	V2.0.0.0	\	\
19	Turntable	MF	MF-7802BS	N/A	\	\
20	Antenna tower	MF	MF-7802BS	N/A	\	\

Conduction Test equipment

Item	Kind of Equipment	Manufacturer	Type No.	Serial No.	Last calibration	Calibrated until
1	LISN	R&S	ENV216	101471	Oct. 22, 2022	Oct. 21, 2023
2	LISN	CYBERTEK	EM5040A	E1850400149	Oct. 22, 2022	Oct. 21, 2023
3	Test Cable	N/A	C01	N/A	Oct. 18, 2022	Oct. 17, 2023
4	Test Cable	N/A	C02	N/A	Oct. 18, 2022	Oct. 17, 2023
5	EMI Test Receiver	R&S	ESCI3	101393	Oct. 17, 2022	Oct. 16, 2023
6	EMC Software	Frad	EZ-EMC	Ver.EMC-CON 3A1.1	\	\



4. CONDUCTED EMISSION TEST

4.1 CONDUCTED EMISSION MEASUREMENT

Test Requirement:	FCC Part15 C Section 15.207
Test Method:	ANSI C63.10:2013
Test Frequency Range:	150KHz to 30MHz
Receiver setup:	RBW=9KHz, VBW=30KHz, Sweep time=auto

4.1.1 POWER LINE CONDUCTED EMISSION Limits

FREQUENCY (MHz)	Limit (dBuV)		Standard
	Quas-peak	Average	
0.15 -0.5	66 - 56 *	56 - 46 *	FCC
0.50 -5.0	56.00	46.00	FCC
5.0 -30.0	60.00	50.00	FCC

Note:

(1) *Decreases with the logarithm of the frequency.

4.1.2 TEST PROCEDURE

- a. The EUT was placed 0.8 meters from the horizontal ground plane with EUT being connected to the power mains through a line impedance stabilization network (LISN). All other support equipments powered from additional LISN(s). The LISN provide 50 Ohm/ 50uH of coupling impedance for the measuring instrument.
- b. Interconnecting cables that hang closer than 40 cm to the ground plane shall be folded back and forth in the center forming a bundle 30 to 40 cm long.
- c. I/O cables that are not connected to a peripheral shall be bundled in the center. The end of the cable may be terminated, if required, using the correct terminating impedance. The overall length shall not exceed 1 m.
- d. LISN at least 80 cm from nearest part of EUT chassis.
- e. For the actual test configuration, please refer to the related Item –EUT Test Photos.

4.1.3 DEVIATION FROM TEST STANDARD

No deviation



4.1.4 TEST SETUP

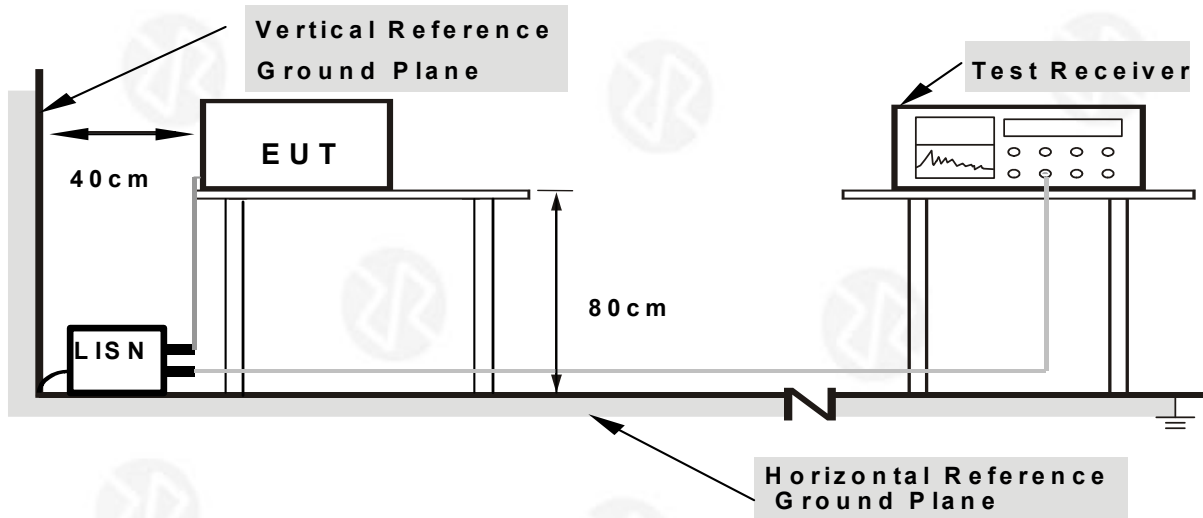

- Note:**
1. Support units were connected to second LISN.
 2. Both of LISNs (AMN) are 80 cm from EUT and at least 80 cm from other units and other metal planes

4.1.5 EUT OPERATING CONDITIONS

The EUT was configured for testing in a typical fashion (as a customer would normally use it). The EUT has been programmed to continuously transmit during test. This operating condition was tested and used to collect the included data.

4.1.6 Test Result

PASS

Please see the next page



Temperature:	26°C	Relative Humidity:	54%
Pressure:	101 kPa	Polarization:	L
Test Voltage:	AC 120V/60Hz		

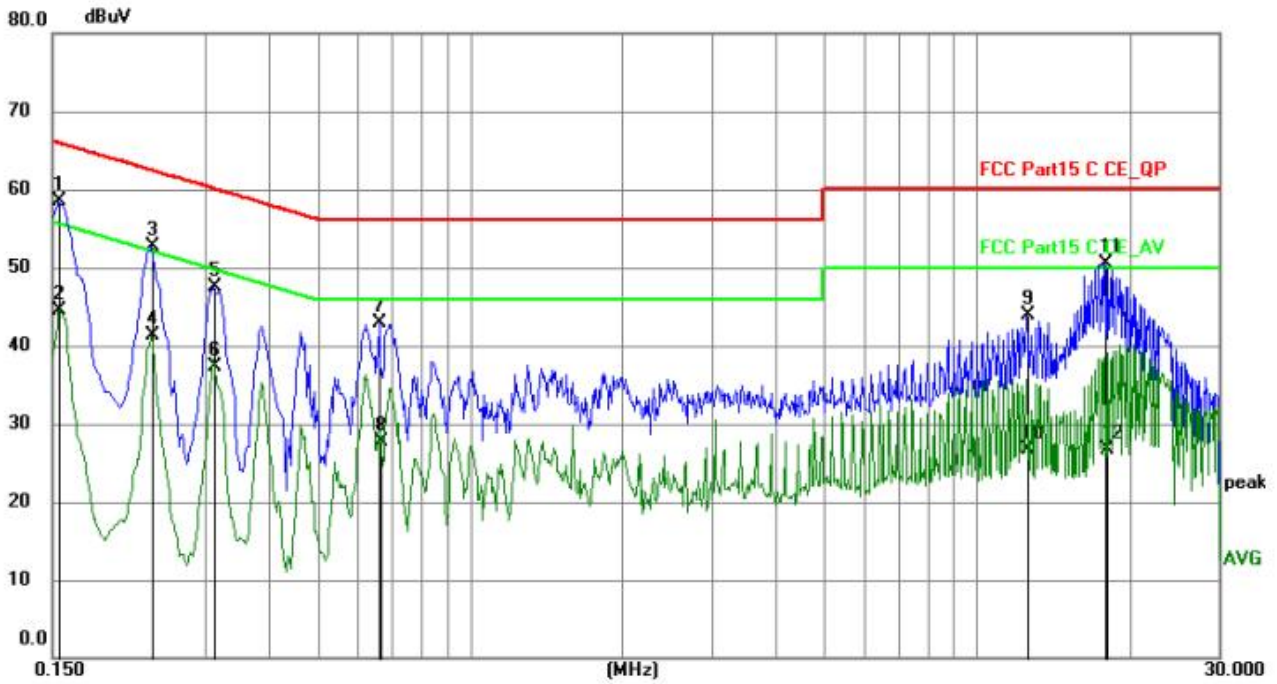

No.	Frequency (MHz)	Reading (dBuV)	Factor (dB)	Level (dBuV)	Limit (dBuV)	Margin (dB)	Detector	P/F	Remark
1	0.1545	45.52	12.91	58.43	65.75	-7.32	QP	P	
2	0.1548	31.55	12.90	44.45	55.74	-11.29	AVG	P	
3	0.2355	40.98	11.75	52.73	62.25	-9.52	QP	P	
4	0.2355	29.61	11.75	41.36	52.25	-10.89	AVG	P	
5	0.3120	36.09	11.41	47.50	59.92	-12.42	QP	P	
6	0.3132	26.00	11.40	37.40	49.89	-12.49	AVG	P	
7	0.6630	32.45	10.51	42.96	56.00	-13.04	QP	P	
8	0.6674	17.15	10.51	27.66	46.00	-18.34	AVG	P	
9	12.5610	35.06	8.82	43.88	60.00	-16.12	QP	P	
10	12.5880	17.82	8.82	26.64	50.00	-23.36	AVG	P	
11	17.8890	40.91	9.56	50.47	60.00	-9.53	QP	P	
12	18.0150	17.20	9.58	26.78	50.00	-23.22	AVG	P	



Temperature:	26°C	Relative Humidity:	54%
Pressure:	101 kPa	Polarization:	N
Test Voltage:	AC 120V/60Hz		

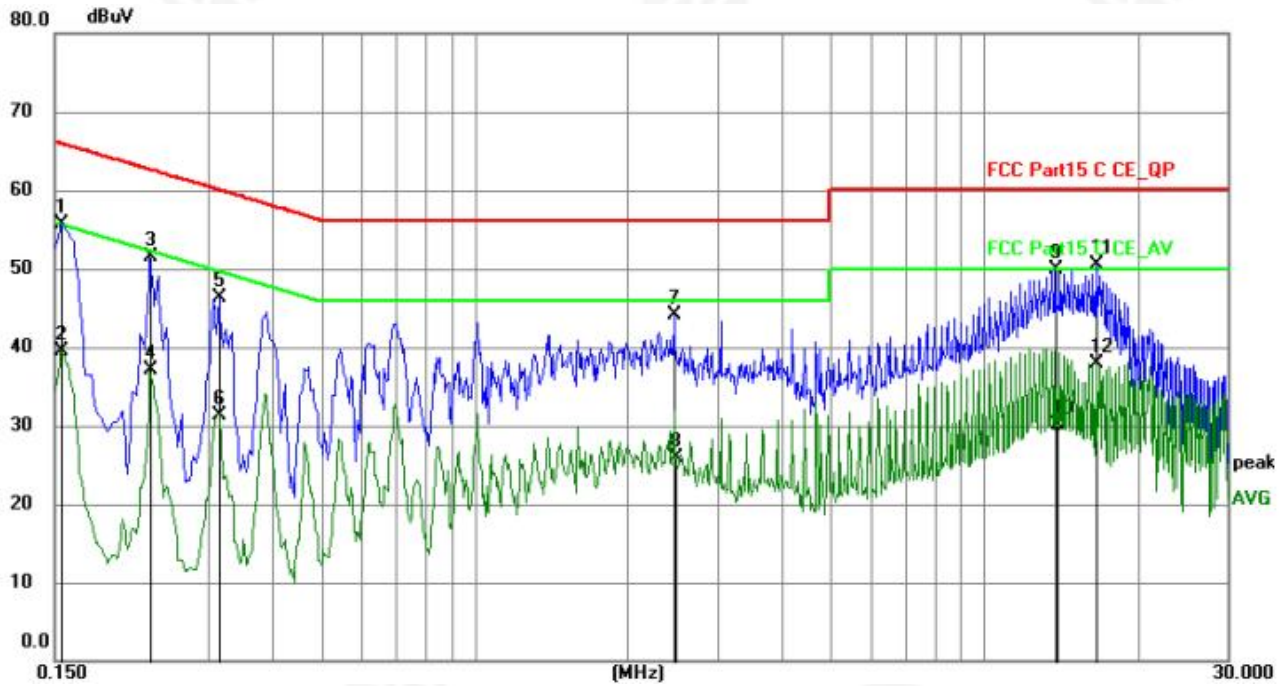

No.	Frequency (MHz)	Reading (dBuV)	Factor (dB)	Level (dBuV)	Limit (dBuV)	Margin (dB)	Detector	P/F	Remark
1	0.1545	42.81	12.91	55.72	65.75	-10.03	QP	P	
2	0.1548	26.60	12.90	39.50	55.74	-16.24	AVG	P	
3	0.2310	39.82	11.78	51.60	62.41	-10.81	QP	P	
4	0.2310	25.25	11.78	37.03	52.41	-15.38	AVG	P	
5	0.3165	34.98	11.39	46.37	59.80	-13.43	QP	P	
6	0.3166	19.88	11.39	31.27	49.80	-18.53	AVG	P	
7	2.4675	34.08	10.07	44.15	56.00	-11.85	QP	P	
8	2.4765	15.81	10.07	25.88	46.00	-20.12	AVG	P	
9	13.8210	40.98	8.99	49.97	60.00	-10.03	QP	P	
10	13.8705	21.09	9.00	30.09	50.00	-19.91	AVG	P	
11	16.6110	41.19	9.39	50.58	60.00	-9.42	QP	P	
12	16.6110	28.46	9.39	37.85	50.00	-12.15	AVG	P	



5. RADIATED EMISSION MEASUREMENT

Test Requirement:	FCC Part15 C Section 15.209				
Test Method:	ANSI C63.10:2013				
Test Frequency Range:	9kHz to 1GHz				
Test site:	Measurement Distance: 3m				
Receiver setup:	Frequency	Detector	RBW	VBW	Value
	9KHz-150KHz	Quasi-peak	200Hz	600Hz	Quasi-peak
	150KHz-30MHz	Quasi-peak	9KHz	30KHz	Quasi-peak
	30MHz-1GHz	Quasi-peak	100KHz	300KHz	Quasi-peak
	Above 1GHz	Peak	1MHz	3MHz	Peak
Peak		1MHz	10Hz	Average	

5.1 Radiated Emission Limits

Limits for frequency below 30MHz

Frequency	Limit (uV/m)	Measurement Distance(m)	Remark
0.009-0.490	2400/F(kHz)	300	Quasi-peak Value
0.490-1.705	24000/F(kHz)	30	Quasi-peak Value
1.705-30	30	30	Quasi-peak Value

Limits for frequency Above 30MHz

Frequency	Limit (dBuV/m @3m)	Remark
30MHz-88MHz	40.00	Quasi-peak Value
88MHz-216MHz	43.50	Quasi-peak Value
216MHz-960MHz	46.00	Quasi-peak Value
960MHz-1GHz	54.00	Quasi-peak Value
Above 1GHz	54.00	Average Value
	74.00	Peak Value



5.2 Anechoic Chamber Test Setup Diagram

(A) Radiated Emission Test-Up Frequency Below 30MHz

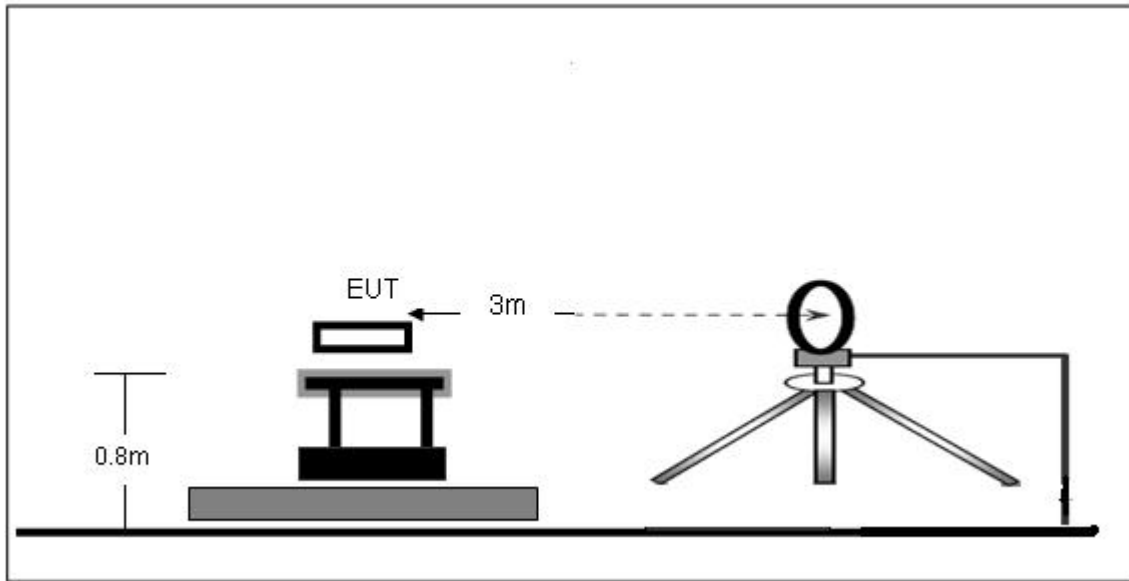

(B) Radiated Emission Test-Up Frequency 30MHz~1GHz

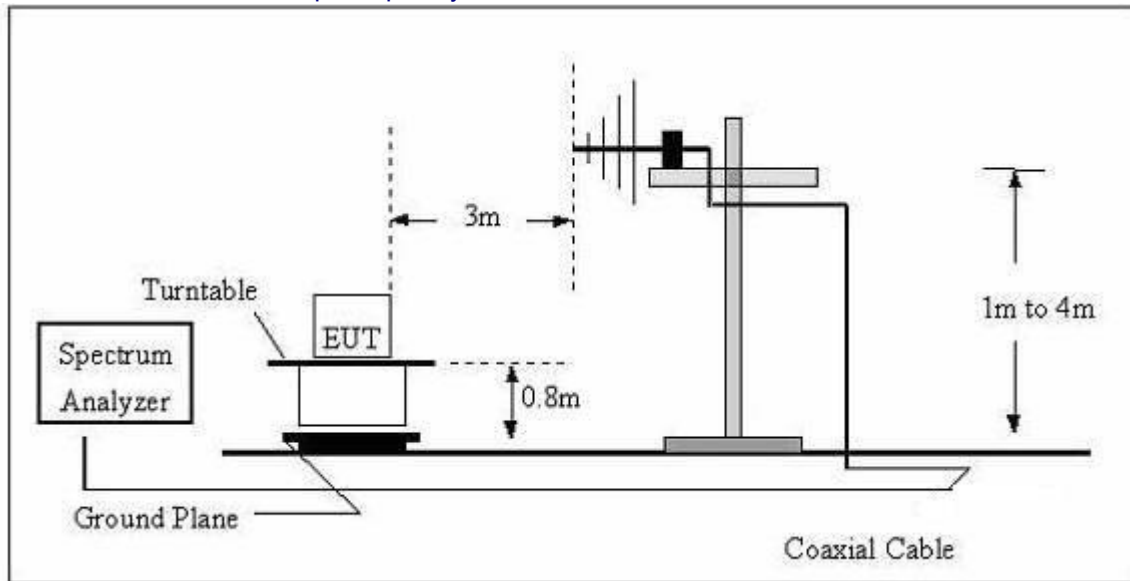

The radiated emission tests were performed in the 3 meters chamber test site, using the setup accordance with the ANSI C63.10-2013. The specification used was the FCC 15.209 and FCC 15.205 limits.

5.3 Test Procedure

The EUT is placed on a turn table which is 0.8 meter above ground. The turn table can rotate 360 degrees to determine the position of the maximum emission level. The EUT is set 3 meters away from the receiving antenna which is mounted on a antenna tower. The antenna can move up and down between 1 to 4 meters to find out the maximum emission level. Broadband antenna (calibrated by dipole antenna) are used as a receiving antenna. Both horizontal and vertical polarization of the antenna are set on measurement.

5.4 DEVIATION FROM TEST STANDARD

No deviation



5.5 Test Result

Measurement data:

Note: Limit dBuV/m @3m = Limit dBuV/m @300m+ 80

Limit dBuV/m @3m = Limit dBuV/m @30m + 40

9 kHz~30 MHz

Frequency	Meter Reading	Factor	Emission Level	Limits	Margin	Detector Type
(kHz)	(dBμV)	(dB)	(dBμV/m)	(dBμV/m)	(dB)	
26.59	42.52	20.33	62.85	119.11	-56.26	PK
26.59	30.42	22.55	52.97	119.11	-66.14	AV
78.61	48.14	21.42	69.56	109.69	-40.13	PK
78.61	44.29	21.16	65.45	109.69	-44.24	AV
127.75	73.44	21.59	95.03	105.48	-10.45	PK
127.75	66.85	20.45	87.30	105.48	-18.18	AV
693.44	30.42	22.39	52.81	70.78	-17.97	QP
984.26	28.41	19.58	47.99	67.74	-19.75	QP
1354.39	30.63	18.47	49.10	64.97	-15.87	QP

Note:

Pre-scan in the all of mode, the worst case in of was recorded.

Factor = antenna factor + cable loss – pre-amplifier.

Margin = Emission Level- Limit.



30MHz-1GHz

Temperature:	26°C	Relative Humidity:	54%
Pressure:	101 kPa	Polarization:	Horizontal
Test Voltage:	AC 120V/60Hz		

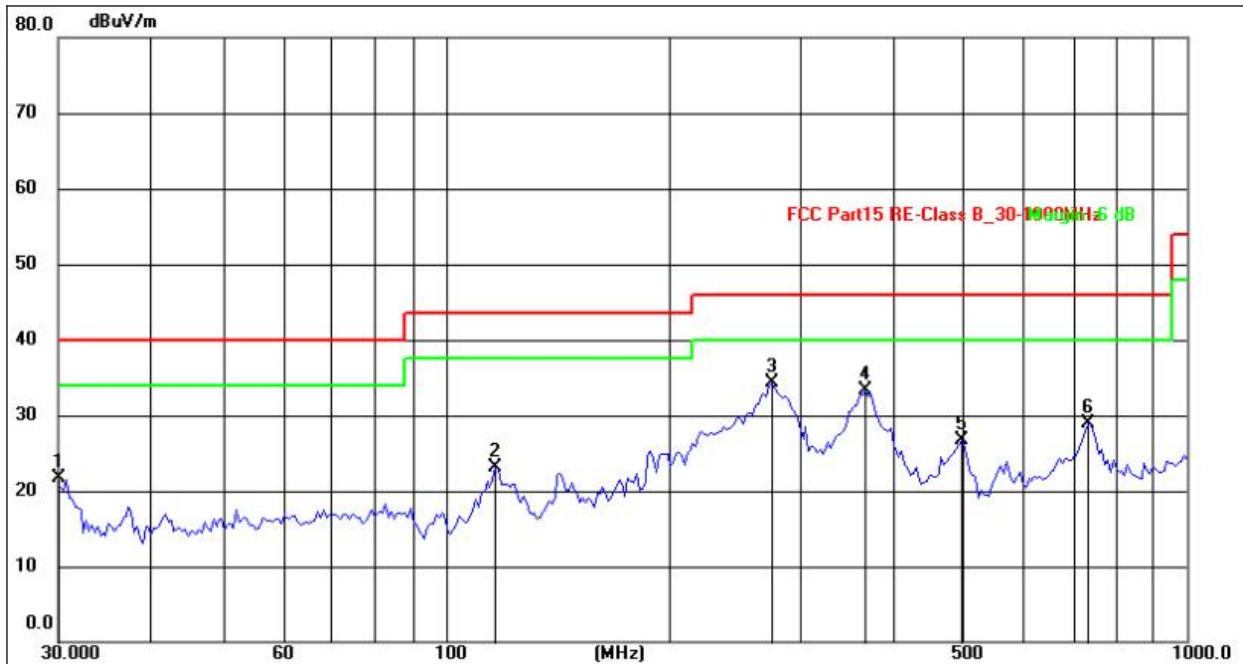

No.	Frequency (MHz)	Reading (dBuV)	Factor (dB/m)	Level (dBuV/m)	Limit (dBuV/m)	Margin (dB)	Detector
1	30.0000	35.97	-14.21	21.76	40.00	-18.24	QP
2	116.7445	41.86	-18.78	23.08	43.50	-20.42	QP
3	275.6398	48.82	-14.61	34.21	46.00	-11.79	QP
4	368.1116	50.00	-16.70	33.30	46.00	-12.70	QP
5	495.9344	38.63	-11.83	26.80	46.00	-19.20	QP
6	735.7802	35.76	-6.80	28.96	46.00	-17.04	QP



Temperature:	26°C	Relative Humidity:	54%
Pressure:	101kPa	Polarization:	Vertical
Test Voltage:	AC 120V/60Hz		

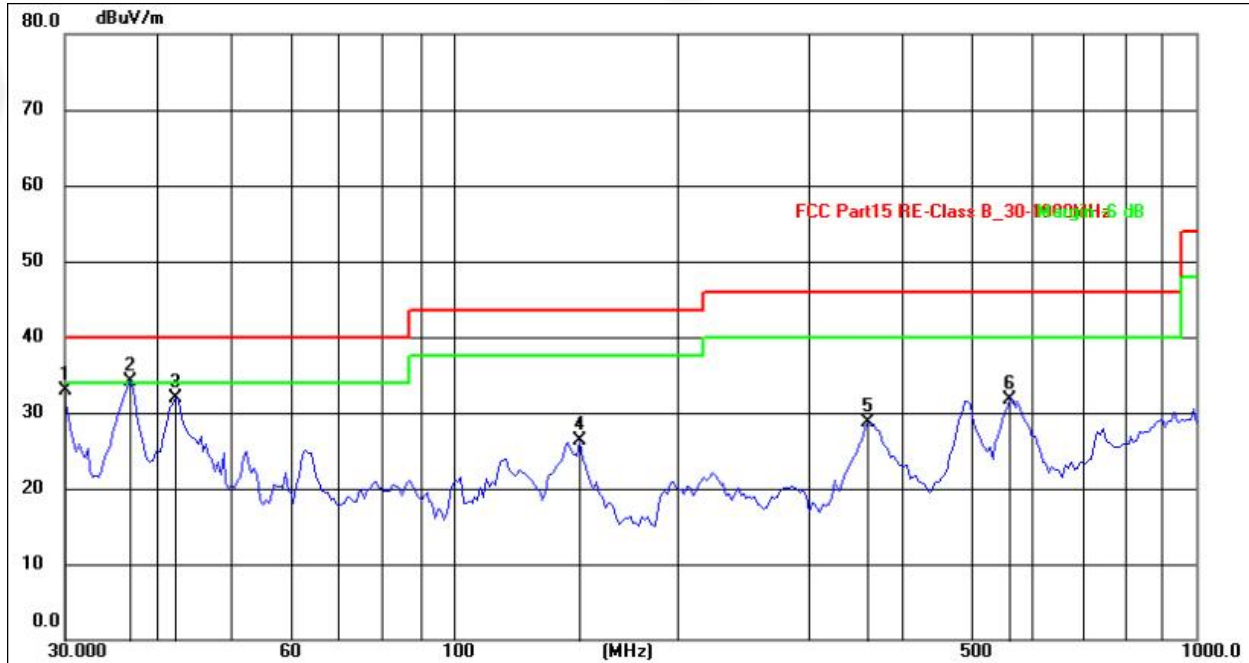

No.	Frequency (MHz)	Reading (dBuV)	Factor (dB/m)	Level (dBuV/m)	Limit (dBuV/m)	Margin (dB)	Detector
1	30.0000	51.42	-18.44	32.98	40.00	-7.02	QP
2	36.7017	51.42	-17.35	34.07	40.00	-5.93	QP
3	42.2281	48.81	-16.96	31.85	40.00	-8.15	QP
4	147.9214	46.84	-20.63	26.21	43.50	-17.29	QP
5	361.7138	45.10	-16.30	28.80	46.00	-17.20	QP
6	560.6928	40.99	-9.27	31.72	46.00	-14.28	QP

Remarks:

- 1.Final Level =Receiver Read level + Antenna Factor + Cable Loss – Preamplifier Factor
- 2.The emission levels of other frequencies are very lower than the limit and not show in test report.



6. BANDWIDTH TEST

1. Set RBW = 100Hz.
2. Set the video bandwidth (VBW) $\geq 3 \times$ RBW.
3. Detector = Peak.
4. Trace mode = max hold.
5. Sweep = auto couple.
6. Allow the trace to stabilize.
7. Measure the maximum width of the emission that is constrained by the frequencies associated with the two outermost amplitude points (upper and lower frequencies) that are attenuated by 20 dB relative to the maximum level measured in the fundamental emission.

TEST SETUP





Temperature:	26 °C	Relative Humidity:	54%
Pressure:	101kPa		

Frequency (KHz)	20dB bandwidth (Hz)	99% bandwidth (Hz)	Result
127.750	605	836	Pass

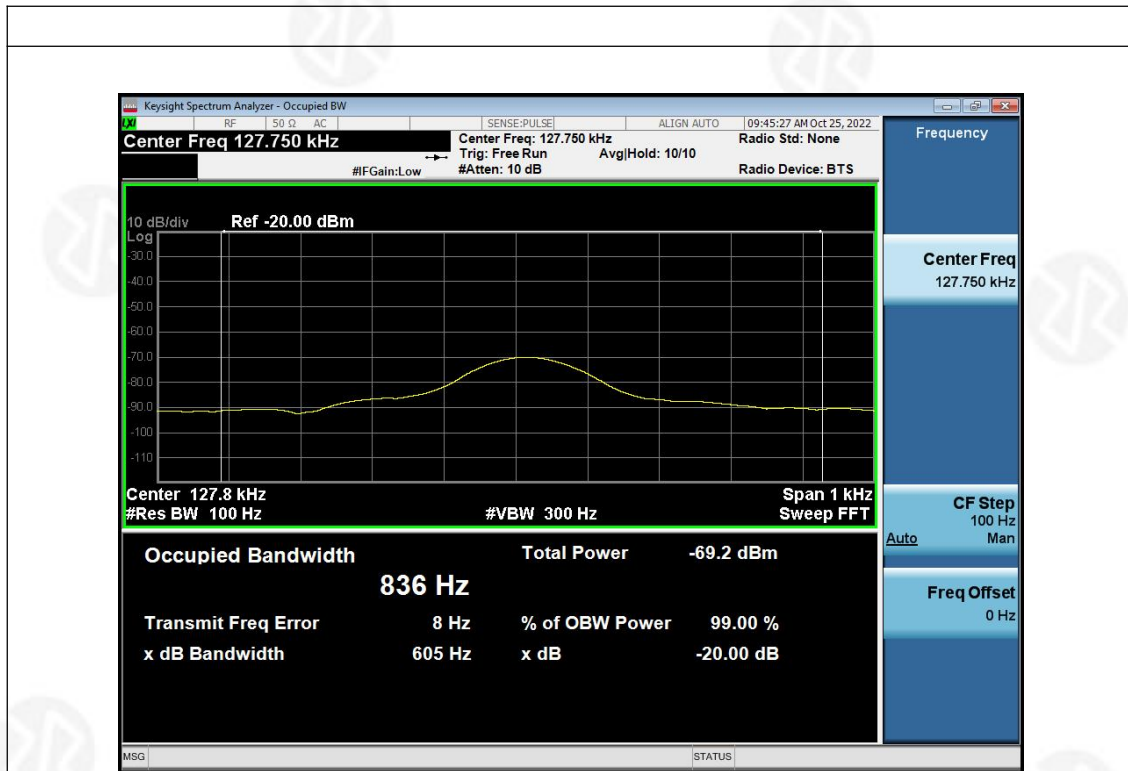



7. ANTENNA REQUIREMENT

Standard requirement:	FCC Part15 C Section 15.203
15.203 requirement: An intentional radiator shall be designed to ensure that no antenna other than that furnished by the responsible party shall be used with the device. The use of a permanently attached antenna or of an antenna that uses a unique coupling to the intentional radiator, the manufacturer may design the unit so that a broken antenna can be replaced by the user, but the use of a standard antenna jack or electrical connector is prohibited.	
EUT Antenna:	
The antenna is Loop antenna, the best case gain of the antennas is 0dBi, reference to the appendix II for details	



8. TEST SETUP PHOTO

Reference to the appendix I for details.

9. EUT CONSTRUCTIONAL DETAILS

Reference to the appendix II for details.

******* END OF REPORT *******