

INCX

Yushan Series X-Ray Flat Panel Detector

Operation Manual

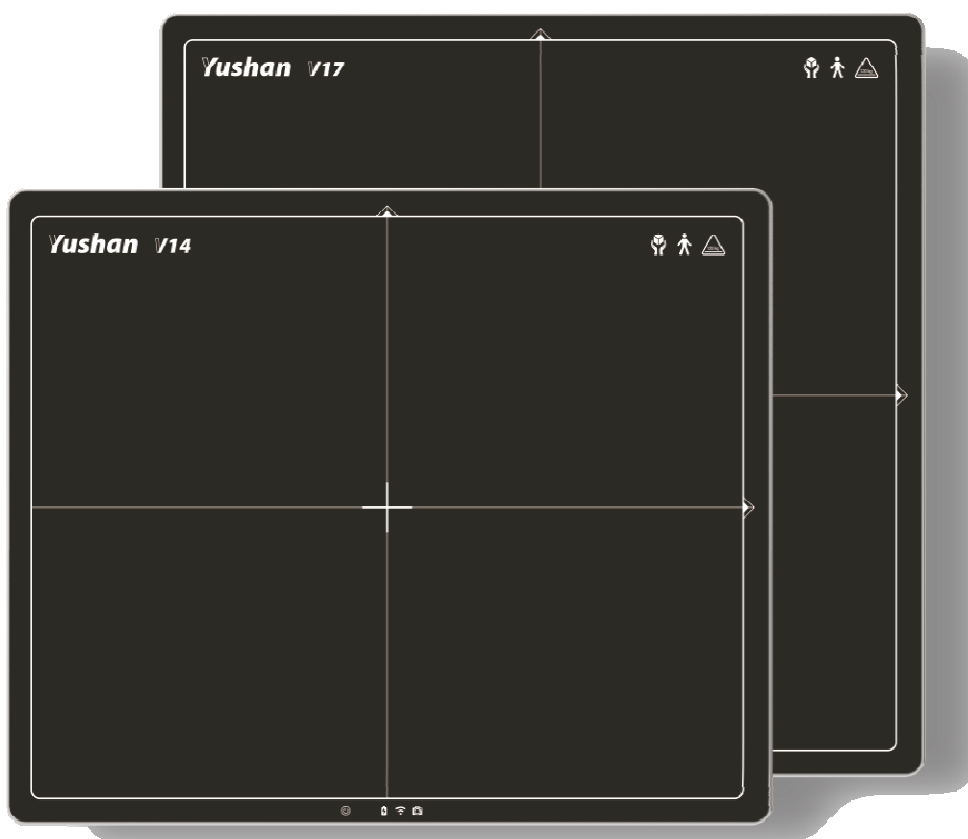

InnoCare Optoelectronics Corp.



Radiologist or any other practitioners licensed should ensure that they have adequate knowledge of the operation prior using the Yushan X-Ray Flat Panel Detector.

This Operation Manual should be studied and understood before proceeding to operate the equipment on patients; it describes details on how to operate the Yushan X-Ray Flat Panel Detector and cautions to be observed when operating it.

After reading this manual, store it nearby the Yushan X-Ray Flat Panel Detector so that you can see it whenever necessary.

"Caution: Federal Law restricts this device to sale by or on the order of a radiologist or any other practitioners licensed by the law of the state in which that person practices to use or order the use of the device."



Caution

This Operation Manual contains confidential and proprietary information of the Manufacturer.

Before using the device, please check local regulations. If any local legislation is violated, use cannot be authorized.

If additional training or material for training is needed, please directly contact our official dealer or InnoCare Representative.

Trademarks

Company names described in this manual are the trademarks or registered trademarks of InnoCare Optoelectronics Corp. or their respective holders.

Windows is the registered trademark of US Microsoft Corporation in the U.S.A. and other countries.

Copyright © 2019 InnoCare Optoelectronics Corporation. All rights reserved.

Document Number: YS-OM-01

Version: A4

Issued date: 2019/08/23



Table of Content

Chapter 1 Introduction	6
1.1 Product Introduction	7
1.2 Product Series	7
1.3 Product Indications for Use	7
1.4 Product Significant Performance Characteristics	7
1.5 Product Intended Patient Population	8
1.6 Product Intended Part of the body or type of tissue applied to or interacted with	8
1.7 Product Intended user profile	9
1.8 Product Intended conditions of use	9
1.9 Product Features	10
1.10 Clinical Guide	10
Chapter 2 Safety and Regulatory	11
2.1 Compliance Standards and Classification	11
2.1.1 Compliance Standards	11
2.1.2 Classification	12
2.2 Contraindications	12
2.3 Power Supply Hazard	12
2.4 Electric Shock Hazard	12
2.5 Abnormalities Hazard	14
2.6 Installation Precautions	14
2.7 Connection Instructions	15
2.8 External Network Connection	15
2.9 System Isolation Instructions	16
2.10 Software Precautions	17
2.11 Disinfection Instructions	17
2.12 Charging the Battery Pack	18
2.13 Battery Pack Instructions	19
2.14 Warnings for Pediatric Use	22
2.15 Other Precautions	23
2.16 Disposal of Waste	24
2.17 Product Labels	24
2.17.1 Identification Label	25
2.17.2 Battery Polarity Label	26
2.17.3 Battery Label	27
2.17.4 Packing Carton Label	27

2.17.5 Adapter Specification Label.....	27
2.17.6 Safety Symbols	28
3.1 How to Connect FPD	29
3.2 Unit Names and the Functions	30
3.2.1 Flat Panel Detector	30
3.2.2 Accessories	31
3.3 LED indicators.....	34
Chapter 4 Basic Operation	35
4.1 Preparing the Flat Panel Detector	35
4.1.1 Type of Flat Panel Detector	35
4.1.2 Number of the Connectable Flat Panel Detector	35
4.1.3 Connecting/Disconnecting the Flat Panel Detector	35
4.1.4 Charging the Battery Pack for the Flat Panel Detector.....	36
4.1.5 Installing/Removing the Battery Pack for the Flat Panel Detector	36
4.1.6 LED Indicator to show battery capacity.....	37
4.2 Detector Connection.....	38
4.2.1 Wire connection	38
4.2.2 Wireless connection.....	39
4.2.3 AP mode connection.....	40
4.3 Starting Up and Shutting Down the Yushan FPD	43
4.3.1 Starting Up the Yushan	43
4.3.2 Overview of User Interface	44
4.3.3 Search and connect FPD	45
4.3.4 Enter the operation and select the mode	46
4.3.5 Performing an Exposure and Image Acquisition	47
4.3.6 Download image from FPD.....	51
4.3.7 Shutting Down the Yushan.....	52
4.4 Guidelines for Pediatric Applications.....	53
4.5 Correction procedure	55
4.5.1 Collect images	55
4.5.2 Correction process	56
4.5.3 Storage of calibration data	58
4.5.4 Standard Configuration.....	59
5.1 Daily User Inspection and Maintenance.....	61
5.1.1 Periodical Inspection	61
Chapter 6 Troubleshooting	62
Appendix A Specifications of FPD	63



A.1 Specifications	63
A.1.1 Reduced Equivalent	63
A.1.2 Power Supply Conditions when Using Back-up Cable	63
A.1.3 Power Supply to Battery Charger	64
A.1.4 Power Consumption and Battery Specification	64
A.1.5 Environmental Conditions	64
A.1.6 Image Performance	66
A.1.7 Radio Waves	68
A.1.8 Reliability and Lifetime	68
Appendix B Electromagnetic Compatibility (EMC)	70
B.1 Yushan FPD	70
B.2 Further Information for IEC 60601-1-2 (EN 60601-1-2)	71
Appendix C Radio Frequency (RF) Compliance Information	78



Chapter 1 Introduction

This manual is intended to provide the operator with an overview of the operation and safety requirements for the Yushan X-Ray Flat Panel Detector. This manual is not intended to provide instructions on actual treatment procedures and it is expected that users should have official radiologist or any other practitioners license prior to using the device. The Manufacturer and Distribution organization assume no liability through the use of the device.

All care has been taken in the preparation and checking of this manual however there is no guarantee provided that all information is correct. The information provided in this manual is subject to change without notice.

Only CE or FDA approved or authorized accessories may be used in this device. The Manufacturer and Distribution organization shall not be held liable or responsible for damages or injury caused as a result of using non-approved accessories. Installation may only be conducted by authorized service personal. Some maintenance and service work also must be carried out by authorized service agents and only those procedures outlined in the operator and service manual are allowed. Any service work carried out by unauthorized person will void all warranties. No circuit diagrams or component part lists are to be provided for this device. If you require technical documentation that is not provided in this manual then please contact the manufacturer or your local distributor in writing with your reasons for wanting them and then a copy of the service manual may be provided. Before using the Yushan X-Ray Flat Panel Detector, the operator should read this manual carefully and pay particular attention to the sections of Safety, Operation and Maintenance.



Caution

InnoCare Optoelectronics Corp. shall not be liable for malfunctions and damages resulting from use under environment conditions outside the range of using conditions for this product such as power supply, installation environment, etc. contained in this manual.

InnoCare Optoelectronics Corp. shall not be liable for malfunctions and damages resulting from natural disasters such as fires, earthquakes, floods, lightning, etc.



1.1 Product Introduction

Yushan X-Ray Flat Panel Detector is an X-ray image acquisition device that is based on flat-panel. This device should be integrated with an operating PC and an X-ray generator. It can do to utilize as digitalizing X-ray images and transfer for radiography diagnostic. Each X ray photon will be converted to electronic signal by scintillator and the sensor array. Electronic signal in the pixel will be readout by driver IC and then become an image before send to PC.

1.2 Product Series

Model	Description
Yushan V14C	Glass version 14"x 17" FPD with Csl
Yushan V14G	Glass version 14"x 17" FPD with GOS
Yushan V17C	Glass version 17"x 17" FPD with Csl
Yushan V17G	Glass version 17"x 17" FPD with GOS

1.3 Product Indications for Use

The Wireless/Wired Yushan X-Ray Flat Panel Detector is intended to capture for display radiographic images of human anatomy. It is intended for use in general projection radiographic applications wherever conventional film/screen or CR systems may be used. The Yushan X-Ray Flat Panel Detector is not intended for mammography, fluoroscopy, tomography, and angiography applications.

1.4 Product Significant Performance

Characteristics

Items		Characteristics
Image resolution(V14C/V14G)		2500x3052
Image resolution (V17C/V17G)		3072x3072
Data		16 bit data
MTF (Modulation transfer function) (Typical)	Csl	0.69 @ 1 lp/mm 0.39 @ 2 lp/mm 0.22 @ 3 lp/mm
	GOS	0.52 @ 1 lp/mm

		0.23 @ 2 lp/mm 0.11 @ 3 lp/mm
DQE (Detector quantum efficiency) (Typical)	Csl	0.51 @ 0.5 lp/mm 0.48 @ 1 lp/mm 0.39 @ 2 lp/mm 0.29 @ 3 lp/mm
	GOS	0.31 @ 0.5 lp/mm 0.27 @ 1 lp/mm 0.16 @ 2 lp/mm 0.09 @ 3 lp/mm
Maximum linear dose (Typical)		88 uGy
Sensitivity (Typical)	Csl	574 lsb/uGy
	GOS	592 lsb/uGy
Dark noise (Typical)	Csl	4.5 LSB
	GOS	7.9 LSB
Lag		<0.5% after 1 minute

1.5 Product Intended Patient Population

Considerations	Requirement Description
Age	- Not restricted
Height	- Not restricted
Weight	- The uniform load of the device is 300kg - The local load on 4 cm diameter of the device is 120kg. *Note: Please evaluate the patient's condition before using.
Health	- Not restricted
Nationality	- Multiple
Sex	- Not restricted

1.6 Product Intended Part of the body or type of tissue applied to or interacted with

- Measurement site: body
- Condition: Intact or wound skin

1.7 Product Intended user profile

Considerations		Requirement Description
Education	Minimum	- Graduate of radiology college
	Maximum	- No maximum
Knowledge	Minimum	- Read and understand 'westernized Arabic' numerals when written in Arial font - Can distinguish of human body - Understands hygiene
	Maximum	- No maximum
Language Understanding	Minimum	- Local language
	Maximum	- Understand the operation manual that is writing in English
Experience	Minimum	- Physician or legally certified operator
	Maximum	- No maximum

Note

Patient should not operate the device by its own, in case result in malfunction of the equipment.

1.8 Product Intended conditions of use

Considerations	Condition
Environment including hygienic requirements	- Non-sterile - Multiple patient use - Less than ten minute contact - Indoor use only - Ambient luminance range: 100 to 1500 lx - Viewing angle: normal to the display $\pm 20^\circ$
Frequency of use	- Reusable - 1day: 200 shot
Location	- In hospital environment
Mobility	- Portable ME equipment to be used on a patient



1.9 Product Features

- 140 micron pixel pitch
- Wide image
- 16-bit dynamic range output
- Exposure times up to 3.0 seconds
- Wireless communication mode or wired communication mode is available. When used in wireless communication mode, an access point and battery pack (optional) are required.

1.10 Clinical Guide

Users may require to attend the training courses held by InnoCare before using. A complete training should consist of the following elements:

- All safety precautions for practitioners and patients when using the device.
- A review of published clinical literature should be conducted to understand the indications and effects of the X-Ray Flat Panel Detector.

Note

It is strongly recommended for Yushan practitioners to attend organized meetings, workshops, seminars, and conferences on use of X-Ray Flat Panel Detector.



Chapter 2 Safety and Regulatory

This Yushan X-Ray Flat Panel Detector has been designed and tested to function in a safe and correct when used as indicated in this manual. Do not use this device before reading and completely understand this Operation Manual. Always observe precautions for safety and only operates the device in a qualified room that provides protection.

2.1 Compliance Standards and Classification

2.1.1 Compliance Standards

- FDA Standards 21 CFR 1020.31 for ionizing radiation emitting products
- FDA Standards 21 CFR 892.1680 for stationary x-ray system
- FCC part15
- European Medical Devices Directive (93/42/EEC)
- EN ISO 13485:2016
- EN ISO 14971:2012
- EN 60601-1: 2006+A1: 2013
- ANSI/AAMI ES60601-1:2005/(R)2012 and A1:2012, C1:2009/(R)2012 and A2:2010/(R)2012
- CAN/CSA C22.2 No. 60601-1:14
- EN 60601-1-2:2015
- IEC 62304:2006/Amd 1:2015
- EN 60601-1-6: 2010+A1:2015
- EN 62366-1: 2015
- EN ISO 10993-1:2009/AC:2010
- EN ISO 10993-5:2009
- ISO 10993-10:2010
- EN 1041:2008
- EN ISO 15223-1:2016
- RED Directive (2014/53/EU)
- RoHS Directive (2011/65/EU)

2.1.2 Classification

- Type of protection against electrical shock: Class I Equipment
- Degree of protection against electrical shock: Type B Equipment
- Degree of protection against harmful ingress of water: IPX6 (An IPX6 rating does not indicate compliance with, and the detectors have not been tested for compliance with, any other IPX_ ratings.)
- Degree of safety of application in the presence of a flammable anesthetics mixture with air or with oxygen or nitrous oxide: Equipment not suitable for use in the presence of a flammable anesthetics mixture with air or with oxygen or nitrous oxide.

2.2 Contraindications

No contraindications present.

2.3 Power Supply Hazard



The power supply to the Yushan is AC 100 to 240V.

To avoid electric shocks, users should always take the following precautions:

- Do not open any covers when it is not necessary.
 - Install the equipment in a location where it will not be exposed to water.
 - Check that the equipment is securely earthed.
 - Check that all of the cables are completely and securely connected.
 - Keep the control cabinet out of reach of patients.
-

2.4 Electric Shock Hazard



INCX

Observe the following precautions when using the cables:

- Do not touch the plug and connector with wet hands. Otherwise, electric shock may result causing death or severe injury.
- Hold the plug or connector when removing the cable.
- Pulling the cable or carrying by holding it may damage the cable, causing fire or electric shock.
- Do not damage or remodel the cable.
- Do not place a heavy object on the cable or lay it under the flat panel detector. Do not step on, pull, forcibly bend, or bundle the cable. Otherwise, fire or electric shock may result.
- Do not use the flat panel detector for the radiographic examination stand if its cable becomes overloaded. Otherwise, the cable may be damaged, causing fire or electric shock.
- Do not touch the back-up cable connector of Yushan, otherwise it may result in electric shock or malfunction of the equipment.

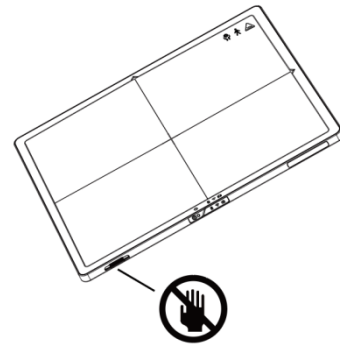

Do not use the equipment in a location where metal particles could come into the equipment. This may cause an electric shock.

Do not disassemble or remodel the equipment. Otherwise, fire or electric shock may result. Keep away from the parts inside the product, which may cause electric shock. If you touch them accidentally, death or severe injury may result.

Do not hit or drop the equipment or subject it to severe shock. Otherwise, the equipment may be damaged. If the damaged equipment is used, fire or electric shock may result.

Do not use the flat panel detector to lift up patient.

In addition, do not apply strong pressure onto the flat panel detector. If applied, the flat panel detector deforms and the waterproof function may be invalid.

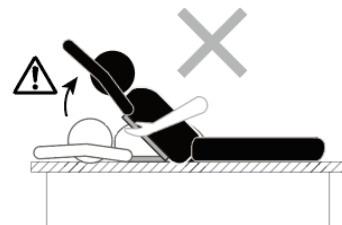

Have the patient take a fixed posture and do not let the patient touch parts unnecessarily. If the patient touches connectors or switches, it may result in electric shock or malfunction of the equipment.

Do not use the flat panel detector without the battery packs. If the battery



packs are not attached, an electric shock may result.

Make sure to use the optional parts and accessories provided by InnoCare. Failure to use the optional parts and accessories recommended by us may result in damage to the equipment and/or electric shock and injury.

Keep the equipment away from patient's body fluids, chemicals, water, etc. Otherwise, it may be damaged, causing fire or electric shock. If necessary, protect the flat panel detector by covering it with a disposable bag.

2.5 Abnormalities Hazard



Warning

If any of the following occurs, immediately turn off the power of each unit, unplug the power cable from the outlet, and then contact our official dealer or InnoCare Representative.

- When smoke, strange odor, or abnormal sound is present.
 - When a foreign object (such as a metal object) or liquid enters the product.
 - When the equipment is dropped or hit and is damaged.
-

2.6 Installation Precautions



Cautions

Do not install the equipment in a location with the following conditions:

- Where the temperature changes sharply.
- Close to heat sources such as a heater.
- Where the equipment may be exposed to water due to water leakage or ingress.
- Where corrosive gas may be generated.
- Where there is excessive dust.
- Where the equipment is subject to frequent or excessive vibration/shock.



- Where the equipment is exposed to direct sunlight.

Use the equipment on a flat place. If the equipment falls, it may cause damage to the equipment or personal injury.

When you move the equipment, place it in the cassette storage box of a mobile X-ray unit or hold it by hand to prevent it from falling. If the cart is used to move the equipment, place it horizontally.

For veterinary or mobile applications, contact our official dealer or InnoCare Representative.

When the devices are used outdoors in wireless communication mode, contact our official dealer or InnoCare Representative.

Do not place any object in a place where removal of the power cable is prevented.

To ensure optimal image quality, it is recommended that you do not use the flat panel detector near devices (motor, transformer, switching supply, etc.) that generate electromagnetic noise.

To ensure optimal image quality, it is recommended that you do not place the cables (power cable, back-up cable, etc.) of the equipment near devices (motor, transformer, switching supply, etc.) that generate electromagnetic noise and their cables.

2.7 Connection Instructions



Warning

Make sure that the devices to be connected to the equipment are authorized for connection.

Connect the panel unit Yushan only to the access point or DR system.

2.8 External Network Connection



Caution

When a setting of the network to which the equipment is connected has been changed, check that the change does not affect the system operation and take measures if necessary.

The setting change may include the following:

- Change of connection destination
- Addition of devices
- Removal of devices
- Update of devices
- Upgrade of devices

After connecting this system to the network with other systems, confirm that the other systems are not affected. If they are affected, take countermeasures such as network separation.



Warning

Make sure to use the optional parts, accessories and networks recommended by us. Failure to use the optional parts, accessories and networks recommended by us may result in damage to the equipment and/or electric shock and injury.

Connect to the Ethernet Network of 100BASE-TX or 10BASE-T prescribed in the IEEE standard 802.3. Do not connect telephone lines to LAN connector. Only UTP-type straight LAN cables of 4-pair Category 5 cable (CAT 5E) or higher are appropriate for connection to this connector. Compliant with FCC part15.

2.9 System Isolation Instructions



Warning

To ensure complete system isolation, never install any unauthorized accessories or other such items.



When it is necessary to install authorized accessories or optional items, contact our official dealer or InnoCare Representative.

Keep equipment other than those used for patients out of their reach to ensure appropriate system isolation.

In normal use, have a patient take a proper positioning for exposure. The operator should operate the system in a place where safety from radiation is ensured. The operator should also make sure before exposure that no one but the patient is in the exposure area and the operating area of the system.

2.10 Software Precautions



Caution

Do not install additional software to the system. Do not uninstall any of the software preinstalled in the system. The system is preinstalled with the appropriate software. If other software is installed or if the existing software is uninstalled, various operational errors may result.

Open-Source Software Contained in This Product

- This product contains third party's software that is made available as open source software or free software.
 - This software is provided "as is" with no warranty of any kind as to its merchantability or fitness for any particular purpose.
 - If you would like to receive such source codes, please contact InnoCare dealer or the service representatives at the agency from which you purchased this product. (Please be noted that any inquiries concerning the contents of source codes should be directed to original licensors of open source software.)
-

2.11 Disinfection Instructions



Warning

INCX

Do not use the following disinfectants at the time of disinfection, which the quality, performance and safety of the equipment cannot be assured.

- Chloric disinfectant which is strongly corrosive to metals and rubber parts.
- Disinfectant whose uses on metals, plastics, and coating are forbidden according to the instructions supplied with the disinfectant.
- Formalin gas and disinfectant sprays that may get inside the equipment.
- Ultraviolet sterilizers.

Disinfectant ethanol is recommended for disinfection. Carefully read the instructions and cautions supplied with the disinfectant before use.

For details on the disinfectant, contact a InnoCare dealer or the service representatives at the agency from which you purchased the disinfectant.



Caution

If flat panel detector is not disinfected, it may lead secondary infection.

Be sure to disinfect with ethanol after use.

Clean the flat panel detector with ethanol for disinfection, etc. for each patient to prevent infection.

2.12 Charging the Battery Pack



Caution

Charging battery only by the back-up cable provided by InnoCare when battery is installed on Yushan flat panel detector or use the battery charger provided by InnoCare Optoelectronics Corp.. For details on operations, refer to the instruction manual for the battery charger.

Do not charge the battery pack near fire or under strong sunshine. If the built-in protection mechanisms are activated by a high temperature, the battery pack cannot be charged. Also, if the built-in protection mechanisms are damaged, the battery pack may be charged with extremely high current and voltage, and abnormal chemical reactions may occur inside the battery pack, causing it to overheat, emit smoke, explode or ignite.



To charge the battery pack, be sure to use the designated battery charger and to observe the charging conditions specified by InnoCare Optoelectronics Corp.. If the battery pack is charged in other conditions (temperature or voltage/current higher than specified, remodeled battery charger, etc.), the battery pack may be overcharged or charged with extremely high current, and abnormal chemical reactions may occur inside the battery pack, causing it to overheat, emit smoke, explode or ignite.

Immediately stop charging the battery pack, if charging is not completed within the specified time. Otherwise, the battery pack may overheat, emit smoke, explode or ignite.

Do not use the flat panel detector near the power cable.

Do not use a faulty or broken battery charger or AC adapter.

2.13 Battery Pack Instructions



Warning

Battery pack requires regular checkup and replacement. Battery capacity begins to warm after a period of time.

If this equipment is not in use for while, store it with the battery pack removed. Not removing the battery pack may cause malfunction.



Caution

The battery pack is used with the flat panel detector. Do not use them in other combinations.

Charge the battery pack only with the designated battery charger. If the battery pack is charged under the charging conditions (voltage, current and charging method) different from those specified by InnoCare Optoelectronics Corp., the battery pack may emit smoke, ignite, explode or leak fluid.

Store the battery pack in a cool and dark place. Recharge the stored battery pack every six months or every year. Otherwise a decrease in battery capacity or other problems may result.



Do not leave the removed battery pack in the car or other places exposed to high temperature. If the battery pack is used or stored in a place where it is exposed to high temperature, the battery pack may emit smoke, ignite, explode or leak fluid.

Use or store the battery pack only in the environmental conditions specified by InnoCare. If the battery pack is used or stored in a place where it is exposed to high temperature, the battery pack may emit smoke, ignite, explode or leak fluid.

When disposing of the battery pack, consult our official dealer or InnoCare Representative.

Do not disassemble or remodel the battery pack. The battery pack is equipped with built-in safety and protection mechanisms. If they are damaged, the battery pack may overheat, emit smoke, explode or ignite.

Be careful not to drop the battery pack. The patient may be injured.

Do not touch the terminal of the battery pack directly. There is a risk of electric shock.

Do not connect the positive (+) and negative (-) terminals with a wire or any metal object.

Do not carry or store the battery pack together with metal objects such as necklaces or hairpins. Otherwise, the battery pack may short-circuit and overcurrent may flow, causing the battery pack to overheat, emit smoke, explode or ignite. Metal objects such as necklaces or hairpins may also become hot.

Do not throw the battery pack into fire or expose it to excessive heat. Otherwise, its insulator may melt, its gas release vent or safety mechanisms may be damaged, and/or its electrolyte may catch fire, causing the battery pack to overheat, emit smoke, explode or ignite.

Do not use or leave the battery pack in a place where it is exposed to high temperature (60C or higher), such as fire or a heater. If the resin separator is damaged due to heat, the battery pack may short-circuit, causing it to overheat, emit smoke, explode or ignite.

Do not immerse the battery pack in water or seawater, and do not allow it to become wet. If the built-in protection mechanisms are damaged, the battery



pack may overheat, emit smoke, explode or ignite.

Do not pierce the battery pack with a nail, hit it with a hammer, or step on it. Otherwise, the battery pack may be damaged or deformed and short-circuit, causing it to overheat, emit smoke, explode or ignite.

Do not subject the battery pack to strong impact or throw it. If the built-in protection mechanisms are damaged, the battery pack may be charged with extremely high current and voltage, and abnormal chemical reactions may occur inside the battery pack, causing it to overheat, emit smoke, explode or ignite.

Do not use an apparently damaged or deformed battery pack. Otherwise, the battery pack may overheat, emit smoke, explode or ignite.

Do not solder the battery pack directly. Otherwise, its insulator may melt, or its gas release vent or safety mechanisms may be damaged, causing the battery pack to overheat, emit smoke, explode or ignite.

Do not reverse the positive (+) and negative (-) terminals. Otherwise, the battery pack may be reverse-charged during charging. As a result, abnormal chemical reactions may occur inside the battery pack, or extremely high current may flow during discharging, causing it to overheat, emit smoke, explode or ignite.

The battery pack has a predetermined polarity. If you cannot connect the battery pack to the battery charger or other equipment, do not connect the battery pack forcefully. Make sure that the terminals are correctly oriented. If the battery pack is connected in reverse, it will be reverse-charged, and abnormal chemical reactions may occur inside the battery pack, causing it to overheat, emit smoke, explode or ignite.

Do not connect the battery pack to an electrical outlet or cigarette lighter socket in a car. Overcurrent may flow to the battery pack due to high voltage applied, causing the battery pack to overheat, emit smoke, explode or ignite.

Do not use the battery pack for equipment other than those specified. Otherwise, the guaranteed performance will be reduced and/or the service life will be shortened. Depending on the equipment to which the battery pack is connected, extremely high current may flow, causing the battery pack to be damaged, overheat, emit smoke, explode or ignite.

If the electrolyte leaked from the battery pack enters the eyes, do not rub them.



Wash the eyes immediately with clean water such as tap water, and consult a doctor. Otherwise, eye injury may result.

Do not use the battery pack in combination with a primary battery such as a dry battery or other battery of a different capacity, type and/or brand. Otherwise, the battery pack may be overcharged during charging, and abnormal chemical reactions may occur inside the battery pack, causing it to overheat, emit smoke, explode or ignite.

Do not put the battery pack in a microwave oven or high-pressure container. Otherwise, the battery pack may be rapidly heated or damaged, causing it to overheat, emit smoke, explode or ignite.

If the battery pack leaks or emits an unusual odor, remove it from fire immediately. Otherwise, the leaked electrolyte may catch fire, causing the battery pack to overheat, emit smoke, explode or ignite.

If you notice an unusual odor, heat, discoloration, deformation or any other abnormality during use, charging or storage, remove the battery pack from the equipment or battery charger, and stop using it. Otherwise, the battery pack may overheat, emit smoke, explode or ignite.

Do not use the battery pack exposed to a strong magnetic field of an MRI system, etc.

Do not use the battery pack immersed in liquid.

Keep the battery away from fire. Avoid the action of short circuit. Never attempt to disassemble the battery pack.

Use the designated chargers to charge the battery pack. Risk of explosion if battery replaced by an incorrect type.

Dispose of used batteries according to the instructions.

2.14 Warnings for Pediatric Use



Warning

If the exposure conditions for average-size adults are applied to children, it may cause excessive radiation exposure.

INCX

Studies show that children are more radiosensitive than adults (i.e. children are at higher risk of developing cancer compared to adults exposed to the same dose of ionizing radiation). Accordingly, in pediatric use, special attention needs to be paid to avoid unnecessary exposure.

Based on the clinical application, pathological conditions of the patient, patient size, and anatomical imaging region, adjust the exposure conditions to use the minimum amount of radiation necessary to obtain appropriate medical images.

For system operation, if children cannot be exposed at an appropriate dose with the AEC, do not use the AEC.

Adjust the exposure conditions to minimize the X-ray exposure time to avoid repeated exposure due to body movement.

2.15 Other Precautions



Warning

No modification of this equipment is allowed.

Because this equipment is not explosion-proof, do not use combustible and explosive gases near the equipment.



Caution

Do not hit or drop the equipment. Otherwise, injury or damage to images, etc. may result.

Be sure to inspect the system periodically.

To assure optimum performance of the equipment, it is necessary to systematically perform maintenance and inspection. For information on maintenance and inspection, contact our official dealer or InnoCare Representative.

Do not perform maintenance and inspection while the equipment is used for a patient.

The institution where the equipment is installed is responsible for its use and



maintenance. In addition, this equipment should not be used by persons other than doctors or suitably trained staff.

Be careful not to expose the flat panel detector to X-ray without a subject.

Although the flat panel detector conforms to IPX6, no warranty is given as to the prevention of water intrusion in the flat panel detector. If the flat panel detector is splashed with water, wipe off moisture and ensure that the flat panel detector is completely dry before use.

As the cables of the equipment are long, be careful not to entangle the cables during use. Also, be careful not to trip over the cables. Falls could result in injury.

Follow the specified procedure when turning off the equipment. Otherwise, the flat panel detector could be damaged by thermal shock.

External equipment intended for connection to signal inputs, signal outputs or other connectors shall comply with the relevant product standard e.g. IEC 60950-1 or IEC 62368-1 for IT-equipment and the IEC 60601-series for Medical Electrical Equipment. In addition, all such combinations – Medical Electrical Systems – shall comply with the safety requirements stated in the general standard IEC 60601-1, edition 3, clause 16. Any equipment not complying with the leakage current requirements in IEC 60601-1 shall be kept outside the patient environment i.e. at least 1.5 m from the patient support or shall be supplied via a separation transformer to reduce the leakage currents.

Any person who connects external equipment to signal inputs, signal outputs or other connectors has formed a Medical Electrical System and is therefore responsible for the system to comply with the requirements. If in doubt, contact qualified medical technician or your local representative.

2.16 Disposal of Waste

It is illegal to place the device in the trash. Please contact the qualified local recycling provides before disposing the device, The disposal procedure should comply with local law.

2.17 Product Labels

INCX

The information of each label can be found in this section and the corresponding location are also presented as the following figure. The following labels are adhered to the Yushan X-Ray Flat Panel Detector.

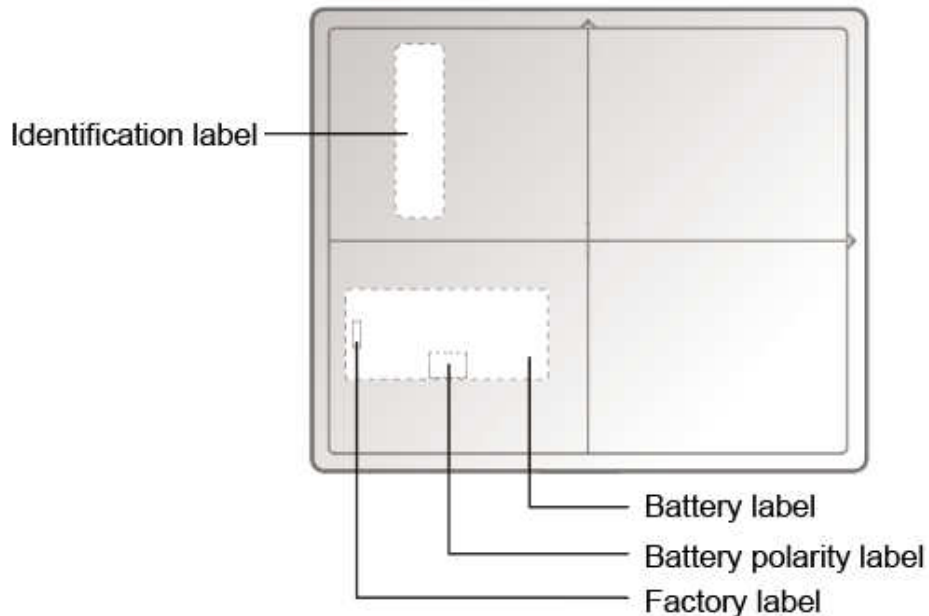

2.17.1 Identification Label

Yushan V14C

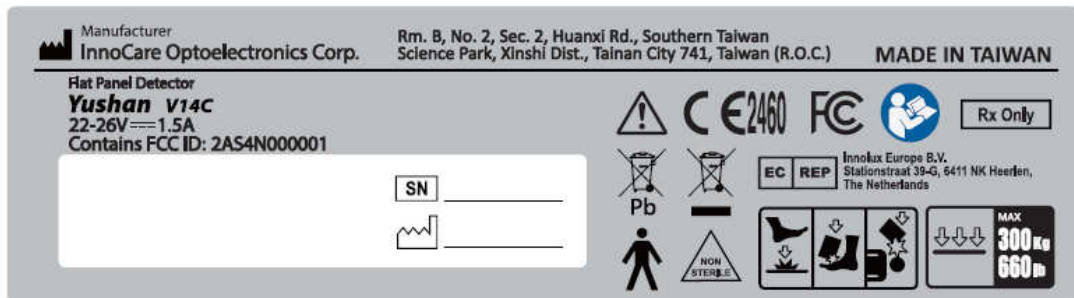

Yushan V14G

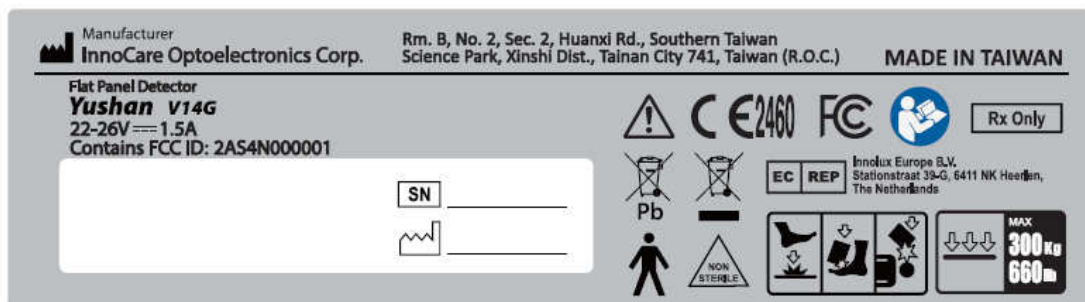

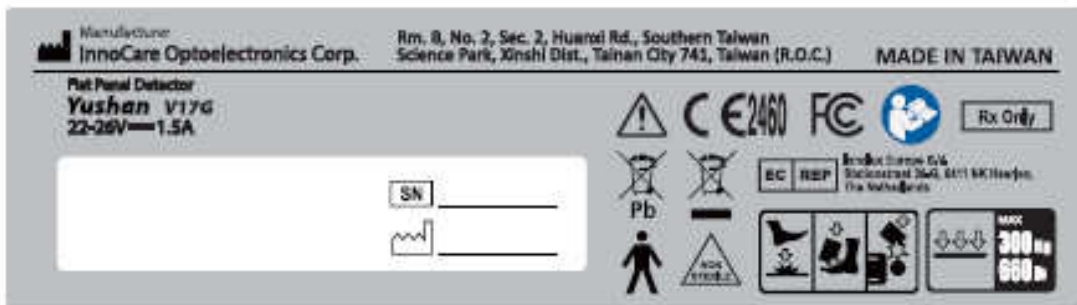
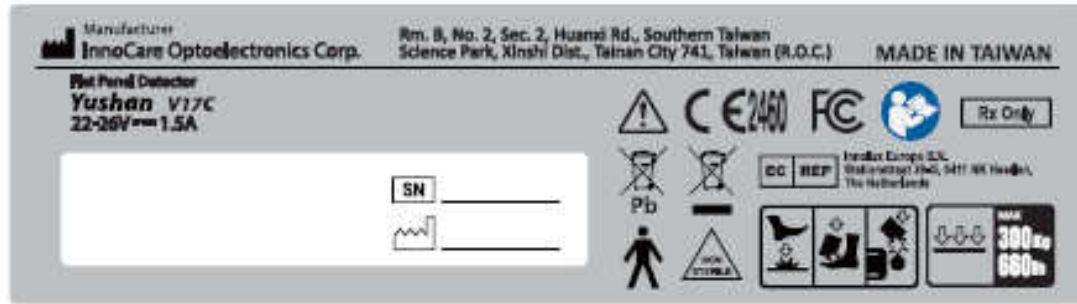

2.17.2 Battery Polarity Label

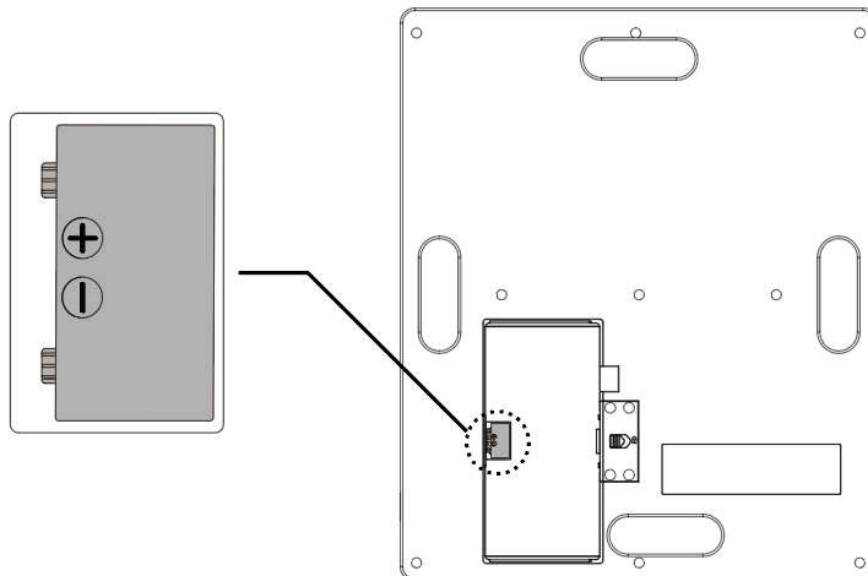

INCX

2.17.3 Battery Label



2.17.4 Packing Carton Label

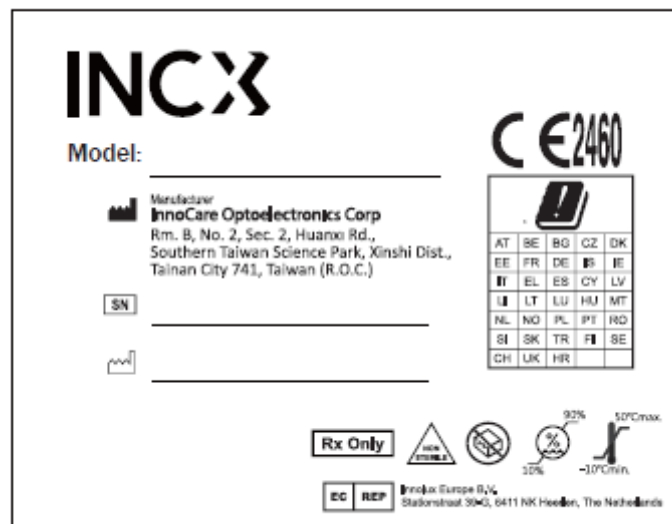

























2.17.5 Adapter Specification Label



2.17.6 Safety Symbols

The following safety symbols are used in the labels or on its body.

Symbol	Description
	Caution
	This symbol indicates compliance of the equipment with Directive 93/42/EEC.
	Federal Communications Commission FCC Marking.
	This symbol indicates that this product is not to be disposed of with your household waste, according to the WEEE Directive (2002/96/EC) and your national law. This product should be handed over to a designated collection point. Improper handling of this type of waste could have a possible negative impact on the environment and human health due to potentially hazardous substances that are generally associated with EEE. At the same time, your cooperation in the correct disposal of this product will contribute to the effective usage of natural resources. For more information about waste, please contact our official dealer or InnoCare representative.
	This symbol indicates that the batteries with more than 0.004% (40 ppm) lead.
	This symbol indicates that the equipment is a Type B Applied Part. IEC 60417/Graphical symbols for use on equipment.
	Refer to instruction manual/booklet
	Serial number
	Manufacturer
	Date of manufacture
	Direct current, DC
	Protective earth (ground)
	Authorized representative in the European Community.
	Prescription use only. Federal Law restricts this device to sale by or on the order of a radiologist or any other practitioners licensed by the law of the state in which that person practices to use or order the use of the device.
	Non-sterile
	Caution for local load
	Do not drop the flat panel detector to the user/patient.
	Entire surface load
	Single point load
	Handle with care
	Power on / off
	Battery
	Link
	Status

Chapter 3 System Configuration

3.1 How to Connect FPD

Yushan FPD can be operated either in wireless connection mode or wired connection mode. When using wired mode, back-up cable is necessary to provide the link from FPD to network switch hub or to PC. User can also connect back-up cable to the adapter provided by InnoCare to give the power to operate or charging its battery. If the adapter is not connected, FPD will be powered by its own battery.

Wireless mode

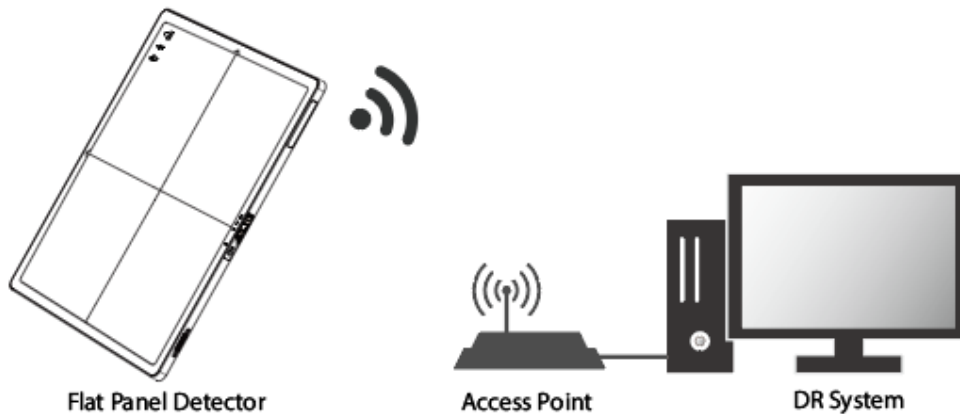

Caution

Do not touch the back-up cable connector of Yushan when in wireless mode, otherwise it may result in electric shock or malfunction of the equipment.

Wireless mode



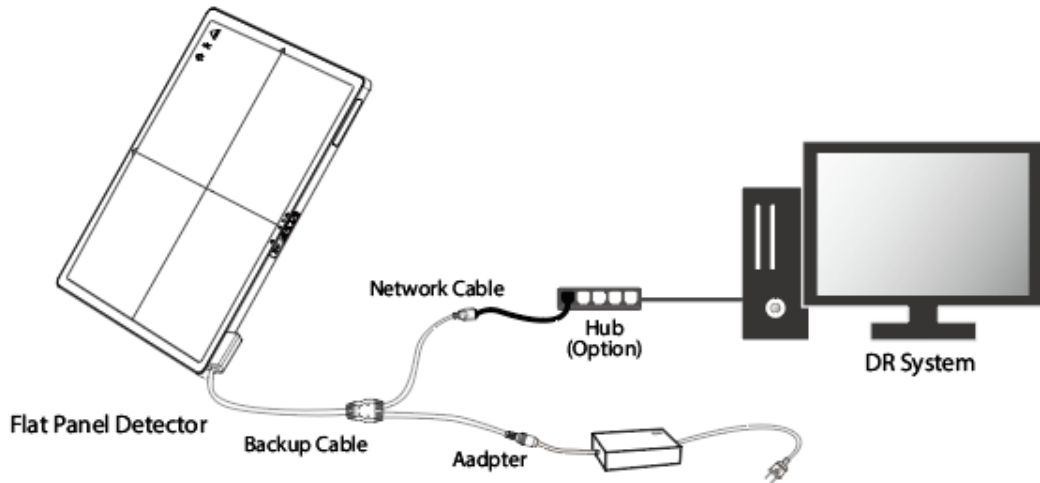

3.2 Unit Names and the Functions

3.2.1 Flat Panel Detector

Unit names and the functions of the Yushan FPD are described below.

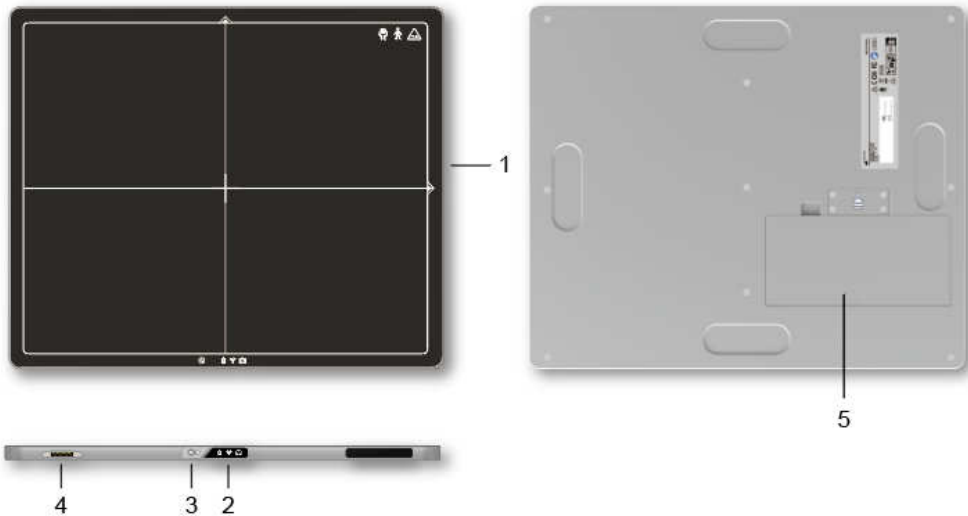

1. Applied part
2. LED indicator
3. Power button
4. Back-up cable connector
5. Battery pack

3.2.2 Accessories

Back-up cable

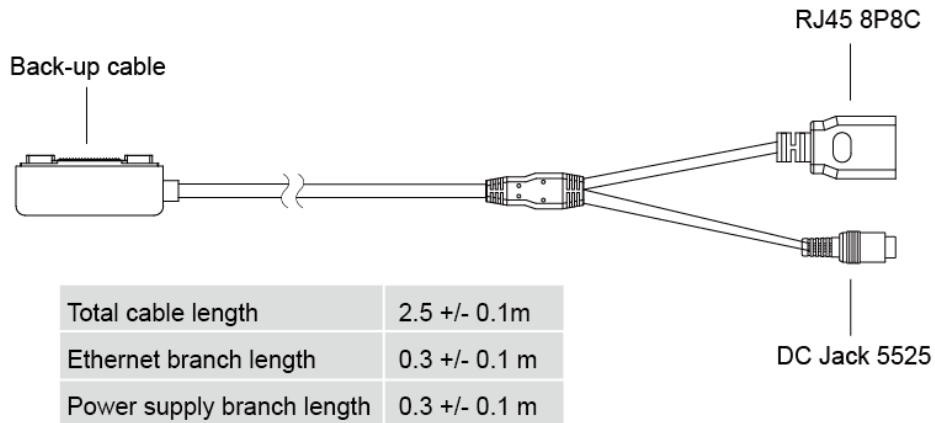

Description: A cable which one side connects the flat panel detector and the other side split into two cable, one is RJ45 connector to connect with ethernet port, and the other side is DC Jack 5.5x2.5 to connect with the output of AC/DC adapter. Cable length: 2.5m

Adapter

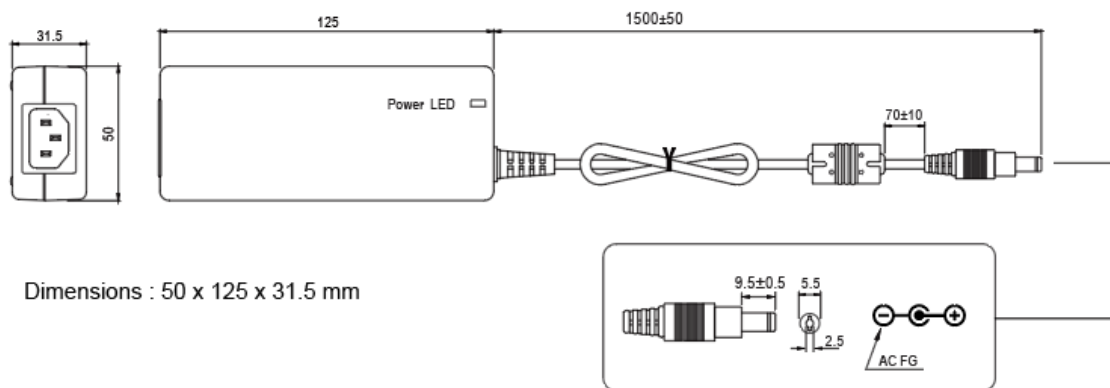

Description: Medical grade AC/DC adapter which is used to provide power either to detector or use to charge the battery installed on FPD.

- Input : 100-250V ~ 1.5-0.75A 50-60Hz
- Output : 24V = 2.5A
- Length : 1.5M
- The adapter must in accordance with IEC 60601-1: 2005 + CORR. 1:2006 + CORR. 2:2007 + AM1:2012.

Battery (Optional)

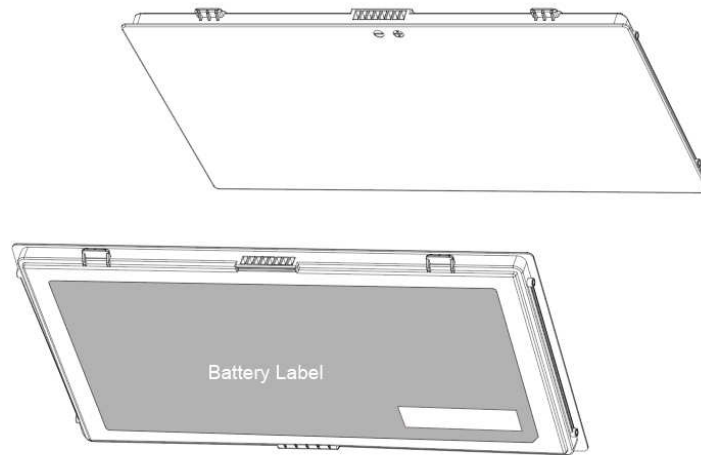

Description: Rechargeable Li-Ion battery designed for Yushan FPD.

- Capacity: 4212 mAh
- Rating voltage: 11.4V, TYP:4212mAh/48Wh
- Weight: ~260g
- UL certified Safety (must in accordance with IEC 62133:2012)

Power Cord

Description: Connection between AC inlet and adapter input.

EU

- PLUG : 6A/250V, CONNECTOR: 10A/250V
- Length : 3M

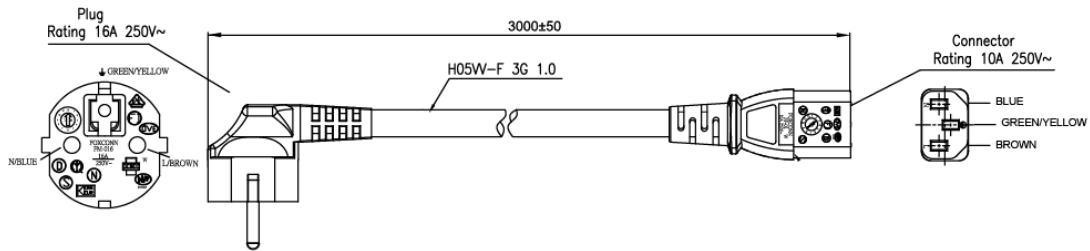

US

- PLUG : 10A/125V, CONNECTOR: 10A/125V
- Length : 2.5M

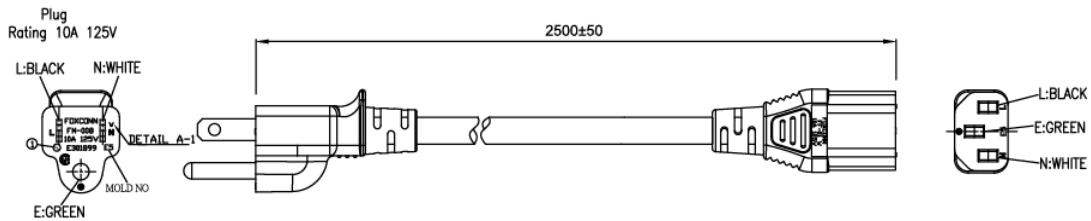

Note:

Every provided accessory is identified to have not received prior 510(k) clearance.



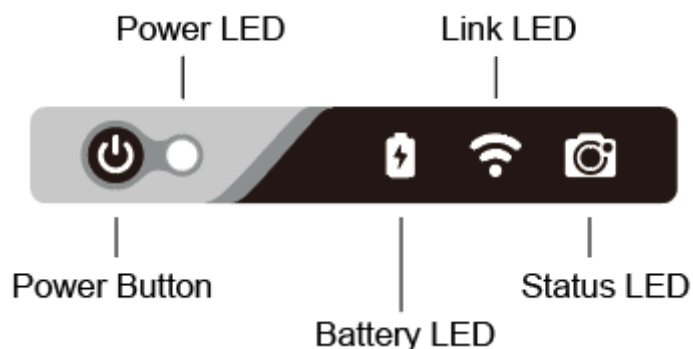

Do not use parts or accessories which are not certified by InnoCare Optoelectronics Corp. or not approved by CE or FDA.

3.3 LED indicators

4 LED indicator are on the side of Yushan series FPD.



The behavior and the relations to the FPD status are described in the table below.

Item	State	Description
	Off	Power off
	Green	Power on
	Yellow	Internal system error
	Green flash	Emergency mode
	Yellow flash	Count down to shutdown
	Off	No charging
	Green	Charging
	Yellow	Low battery
	Green flash	No primary battery
	Off	No connection
	Green	FPD connected
	Green flash	FPD has IPv4 or IPv6 address configured (Not include AP mode)
	Off	Wait and standby
	Green	Detector selected
	Yellow	Internal error
	Green flash	Busy

Chapter 4 Basic Operation

4.1 Preparing the Flat Panel Detector

This section describes how to prepare the flat panel detector.

4.1.1 Type of Flat Panel Detector

Yushan V14C, Yushan V14G, Yushan V17C, Yushan V17G

4.1.2 Number of the Connectable Flat Panel Detector

Up to 5 panels can connect to system at the same time.

4.1.3 Connecting/Disconnecting the Flat Panel

Detector

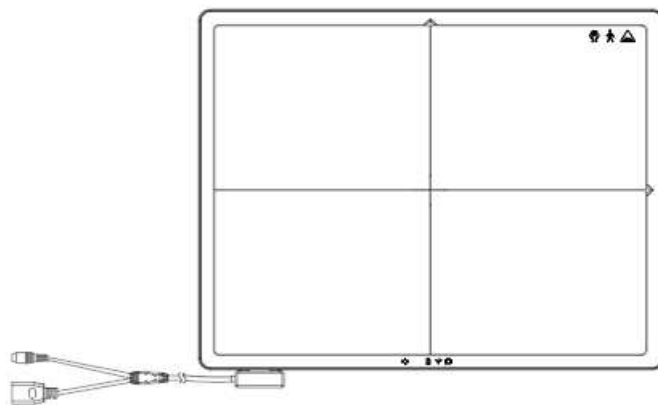

▼ Connecting the FPD

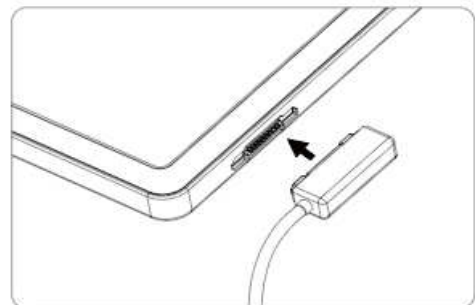

▼ Disconnecting the FPD

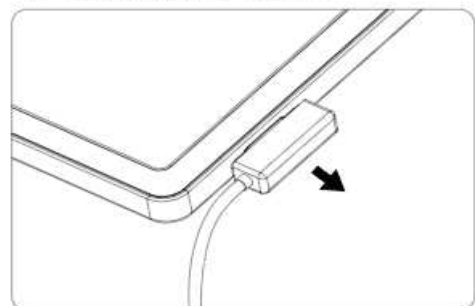

Do not place the connector on floor.



Make sure that the latches on both sides are properly engaged when connecting the connector. If the connector is inserted incompletely, the power may turn off.

 **Caution**

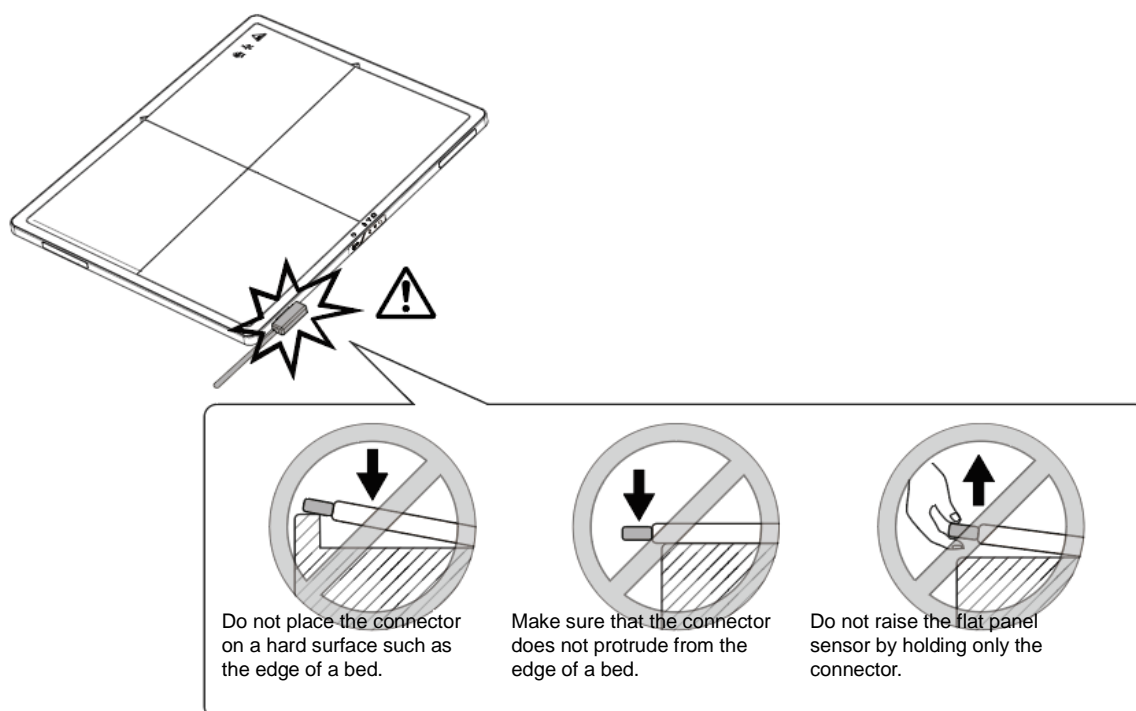

4.1.4 Charging the Battery Pack for the Flat Panel

Detector

Use the battery charger recommended by InnoCare Optoelectronics Corp.. For details on operations, refer to the instruction manual for the battery charger.

4.1.5 Installing/Removing the Battery Pack for the Flat

Panel Detector

Follow the procedure below to install/remove the battery pack for the flat panel detector. When installing/removing the battery pack, place the flat panel detector on a flat place.

Do not remove the battery pack until a processed image appears in the window of the image processing unit after the exposure.

Remove the battery pack

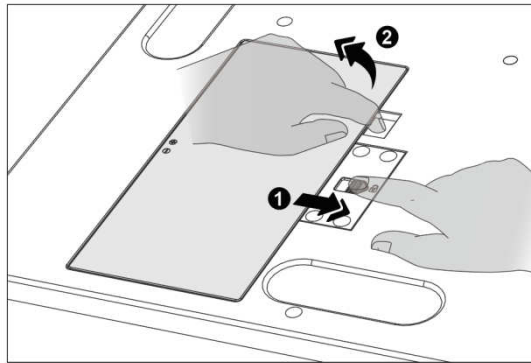

Step ① Slide the arrow switch toward right side and hold it.

Step ② Pick up the edge of battery by finger, then lift it.

Install the battery pack

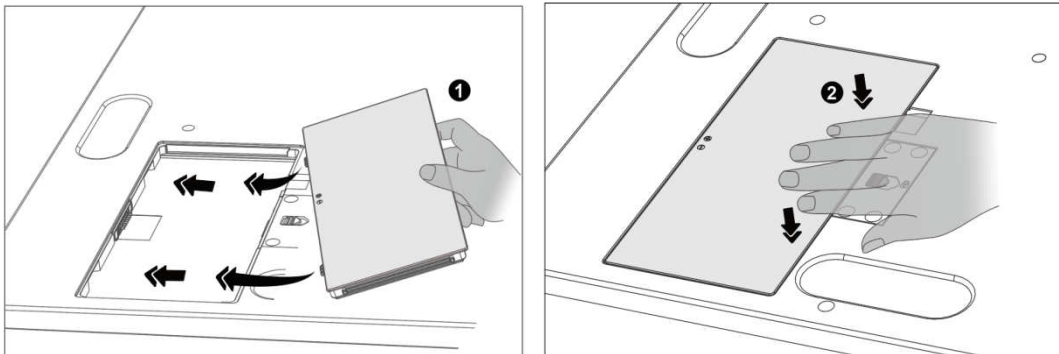

Step ① Following the picture and install the battery.

Step ② Push the battery pack and make sure the battery is tightly installed.

4.1.6 LED Indicator to show battery capacity

By short press LED at any time, even when power is off. LED will show current remaining capacity. If the main battery is not exist, it will show the second battery capacity by flashing light.



4.2 Detector Connection

Yushan detector can be connected to system either by wireless or by wire cable. Yushan FPD use Dynamic Host Configuration Protocol (DHCP) to assign IP address automatically.

4.2.1 Wire connection

The default address of Yushan is 192.168.11.100. User need to set the computer to the same domain as Yushan. First, open the IPV4 of computer's local network management interface, and change the IP address to 192.168.11.1 and subnet mask to 255.255.255.0.

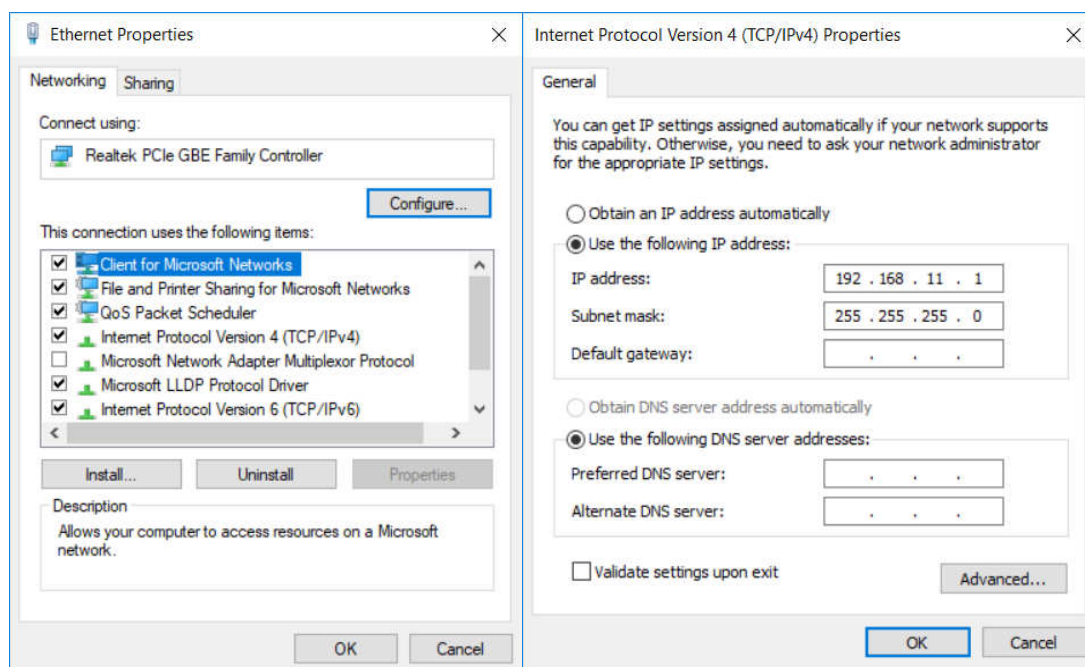

After connection established, open Cmd.exe and enter 'ping 192.168.11.100' then press enter to check the network. If success, there is a reply from FPD as below.

```
Command Prompt - ping 192.168.11.100 -t
Microsoft Windows [Version 10.0.17134.48]
(c) 2018 Microsoft Corporation. All rights reserved.

C:\Users\z7611>ping 192.168.11.100 -t

Pinging 192.168.11.100 with 32 bytes of data:
Reply from 192.168.11.100: bytes=32 time=2ms TTL=64
Reply from 192.168.11.100: bytes=32 time=2ms TTL=64
```

4.2.2 Wireless connection

SDK command is used to setup SSID and password of wireless access point. This setup to FPD need to be done first before wireless connection. (Note: SDK is enclosed in the packaging)

Users can set client mode parameters through the software interface. Choose wireless in configuration interface.

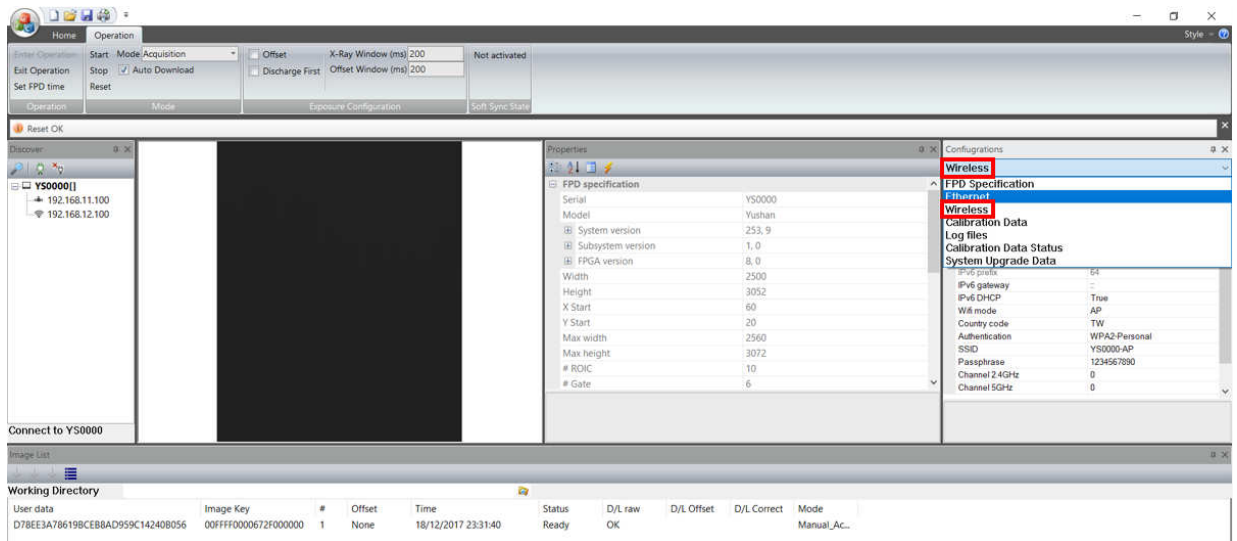

Choose the "Client".

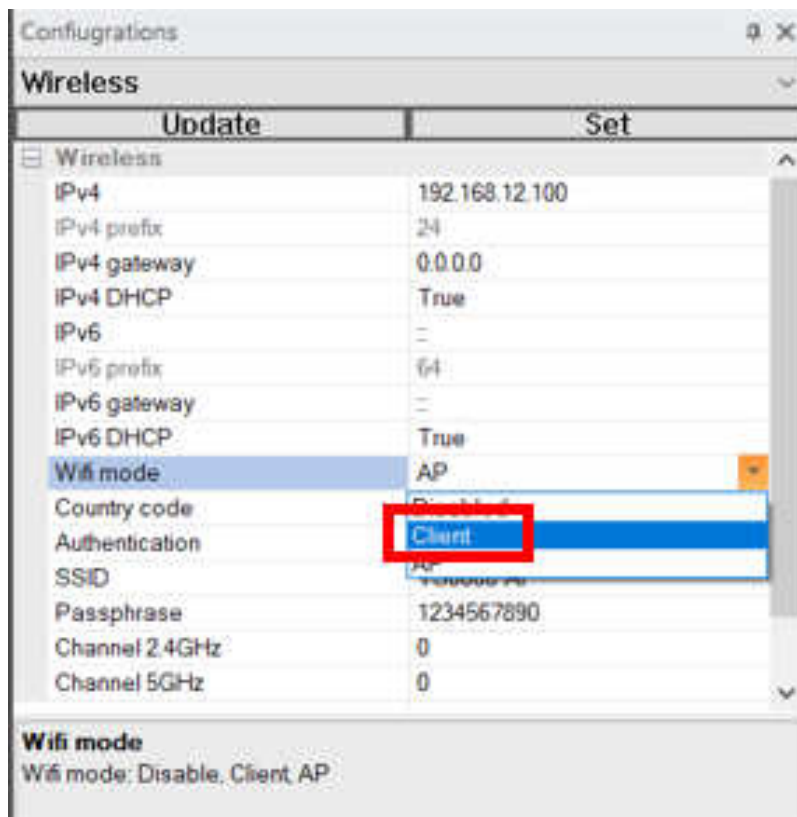



Set the SSID and pass phrase of AP to be connected to the product.

Configurations	
Wireless	
Update	Set
Wireless	
IPv4	192.168.12.100
IPv4 prefix	24
IPv4 gateway	0.0.0.0
IPv4 DHCP	True
IPv6	::
IPv6 prefix	64
IPv6 gateway	::
IPv6 DHCP	True
Wifi mode	AP
Country code	TW
Authentication	WPA2-Personal
SSID	X - RAY - LC
Passphrase	1234567890
Channel 2.4GHz	0
Channel 5GHz	0

SSID
SSID of connected AP/software AP

4.2.3 AP mode connection

Users can set AP mode parameters through the software interface.

Choose wireless in configuration interface.

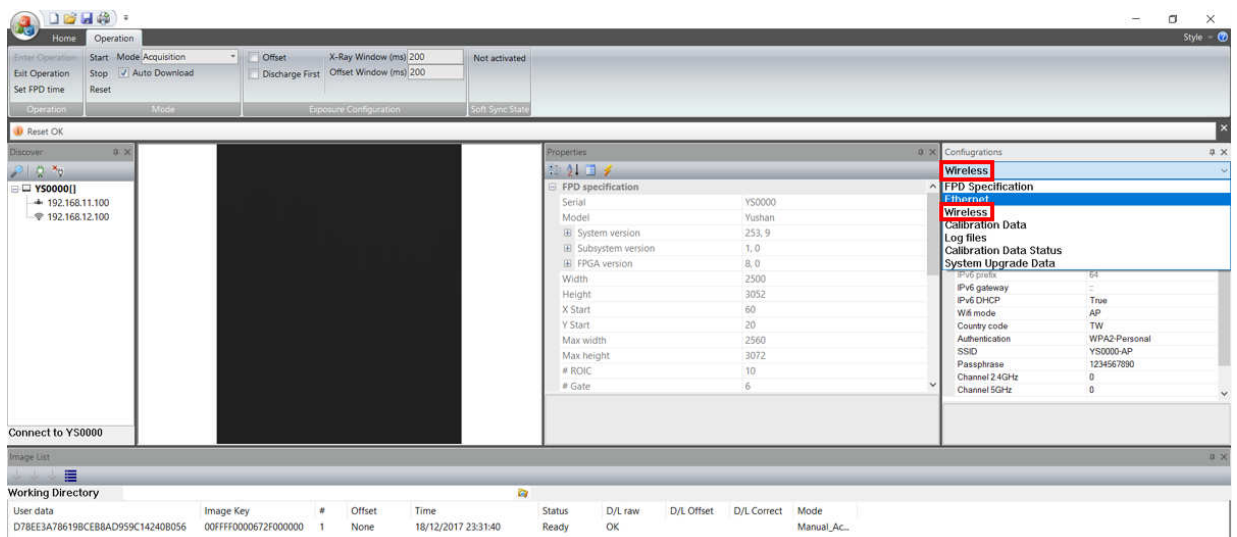



Choose the "AP".

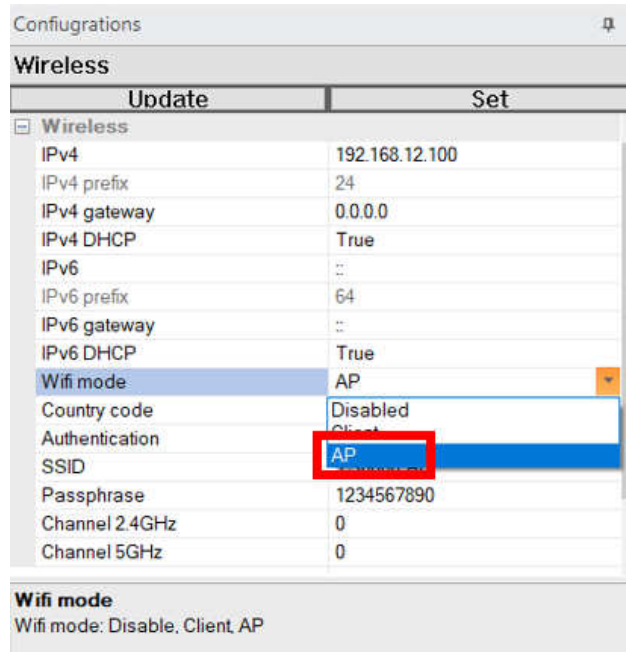

Set the SSID and pass phrase of product.

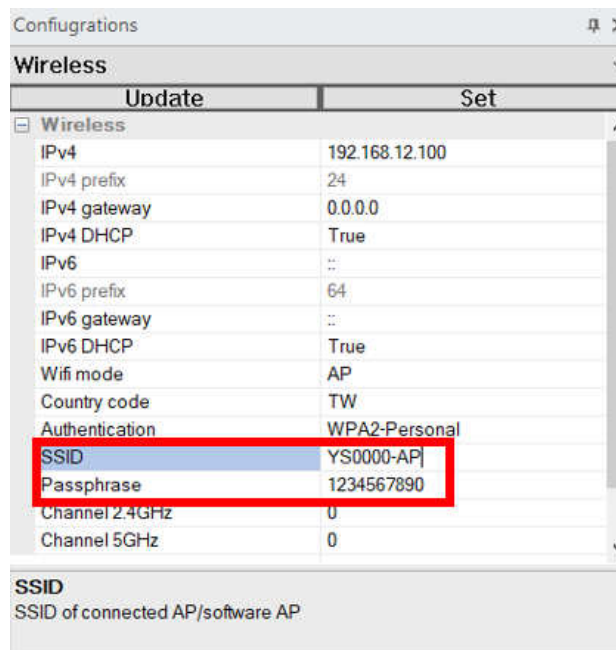

User needs to set the computer to the same domain as Yushan (Wifi). First, open the IPV4 of computer's local network management interface, and change the IP address to 192.168.11.1 and subnet mask to 255.255. 255.0.

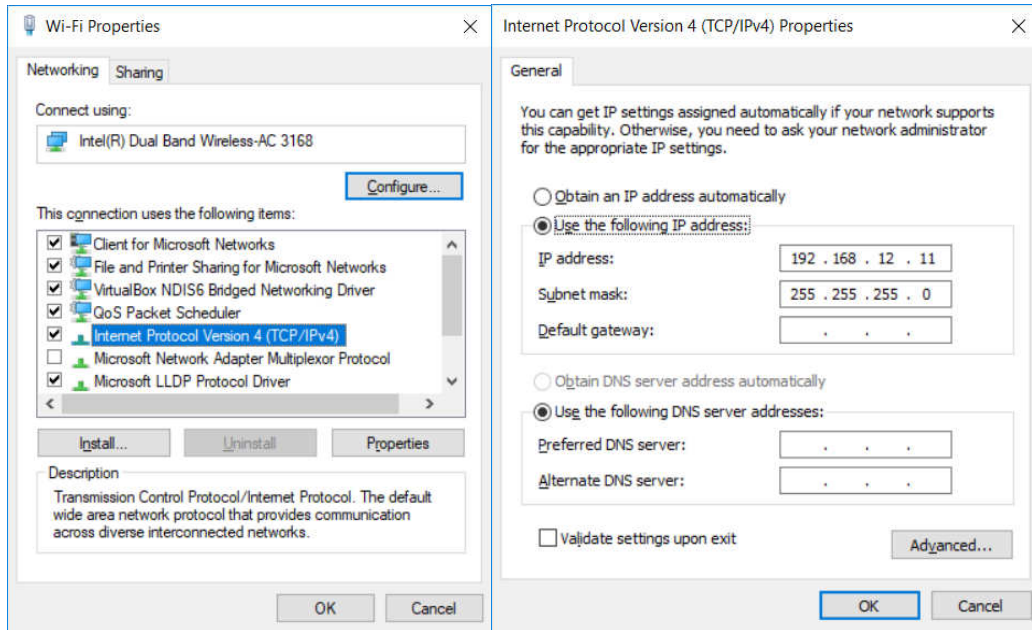

4.3 Starting Up and Shutting Down the Yushan FPD

This section explains how to start up and shut down the Yushan.

4.3.1 Starting Up the Yushan

1. Press the power button for more than 2 second to start the FPD.

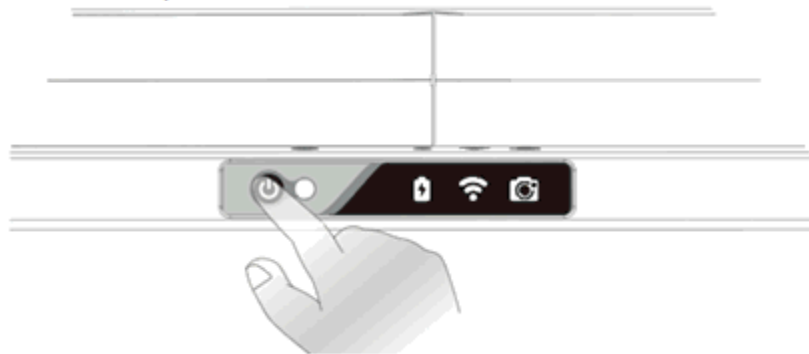

2. Make sure that the power LED light in green.



3. Power LED will still light in green. Wait status LED stop flashing.

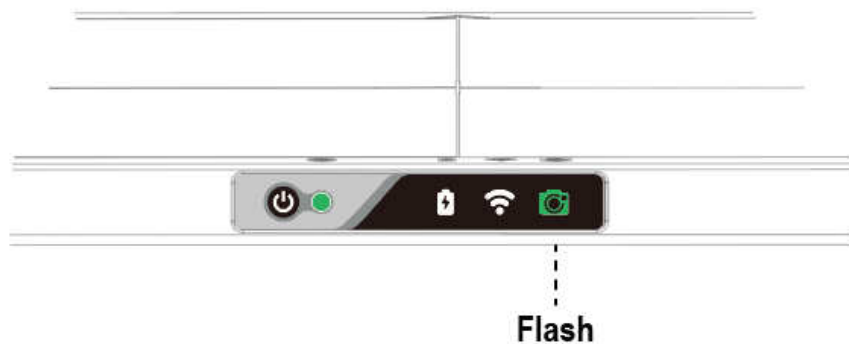

4. Wait Status LED light in green (ready for exposure)

4.3.2 Overview of User Interface

■ Operation

o **Enter Operation:** Make FPD enter operation state. User can choose exposure mode after FPD is in operation state.

o **Exit Operation:** Make FPD exit operation state.

o **Set FPD time:** Synchronize the time between PC and RTC of FPD.

■ Mode

o **Start:** Make FPD operate in selected exposure mode.

o **Stop:** Make FPD stop selected exposure mode and return to *Idle* in operation state.

o **Reset:** Reset the image module (Clear some alert flag).

o **Mode:** Choose exposure mode (AED repeat / AED one shot / Soft Sync / Acquisition / Discharge).

o **Auto Download:** Download the image to PC after the exposure.

o **Don't Save to eMMC:**

- The image is saved in the non-volatile storage of FPD.
- The image is only stored in buffer of FPD and will be overwritten by subsequent exposure image.

o **Corrected Image:** Download the corrected image of AED mode. (App ignores this parameter if FPD is not operated in AED mode)

o **User Key:** A number for user key generation. The number increases by 1 after each exposure.

■ Exposure Configuration (Please refer to AED / Acquisition section for more detail)

o **Offset:**

- Taking offset image depends on exposure mode
 - **Offset After Exposure (OAX):** AED
 - **Offset Before Exposure (OBX):** Acquisition
- **Do not take offset image**

o **Clear1:** Discharge before take OBX of Acquisition mode.

o **Delay OBX:** If this option is checked, there will be an x-ray window delay between discharge and OBX. Otherwise the OBX is acquired immediately after **Clear1**.

o **Clear2:** Discharge before take exposure image.

o **X-Ray Window (ms):** X-Ray window in milliseconds. [2.5ms~3s]

o **Offset Window (ms):** Offset window in milliseconds. [2.5ms~3s]

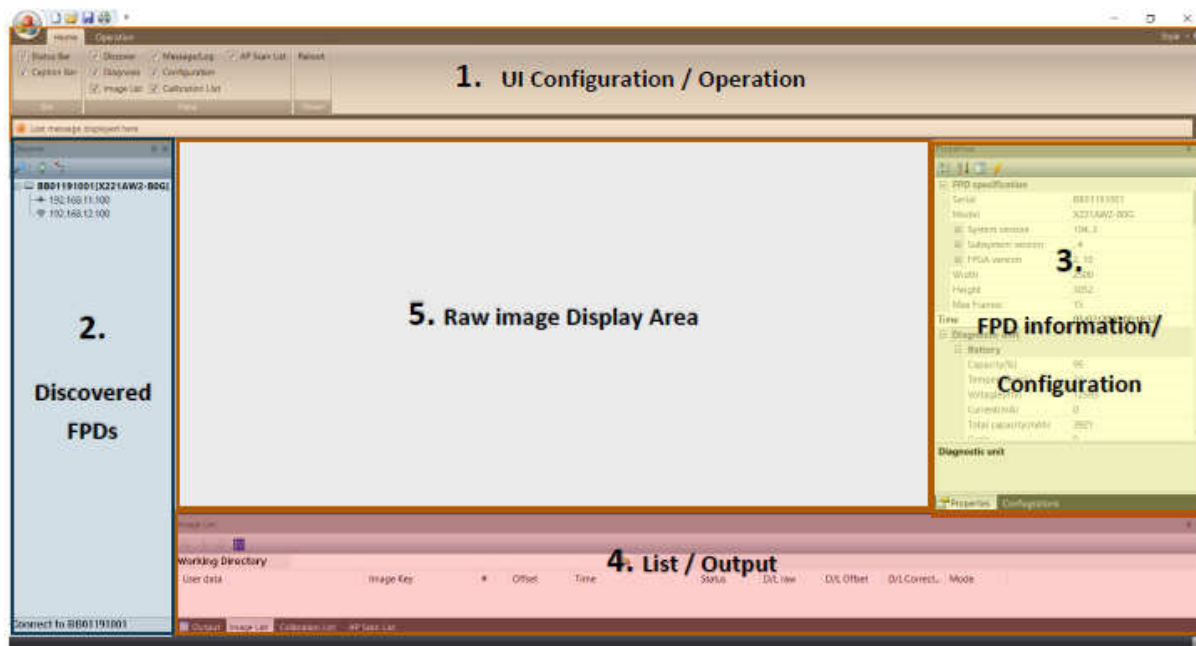

4.3.3 Search and connect FPD

Click 1 to discover all reachable FPDs



Expand the selected entry of the list, and select connection by Ethernet or Wifi. Then click 2 to connect the specified FPD. Note: Please make sure the IP of Host PC and the selected connection is in the same local area network.

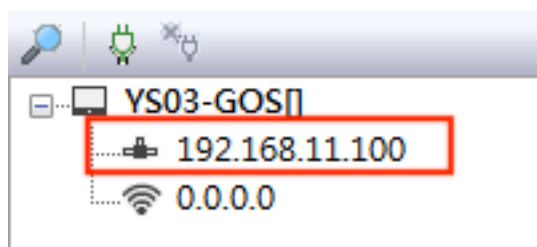

4.3.3.1 Wireless connection

Expand the selected entry of the list, and select connection by Ethernet. Then click 2 to connect the specified FPD. Note: Please make sure the host PC is connected to the specified AP.

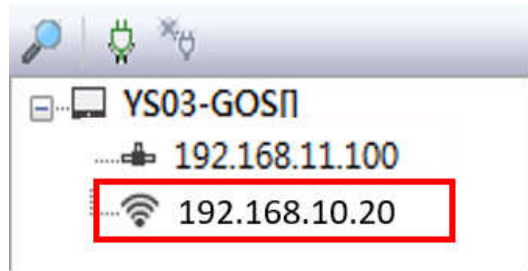

After establishing the connection, you can check the diagnosis field on the right to confirm the information of Yushan products. The message appears to indicate a successful connection.

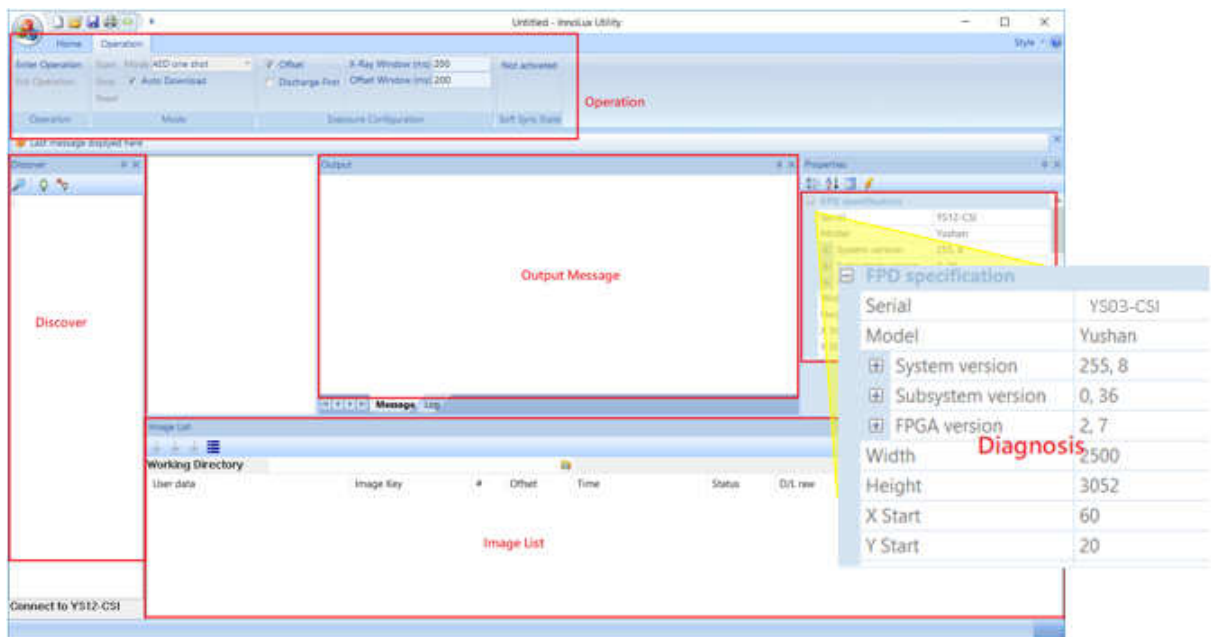

After connection is established, you can use 3 to disconnect the FPD. Note: Connecting to other FPD disconnect the currently connected FPD automatically

4.3.4 Enter the operation and select the mode

After connecting to FPD, switch to Operation tab



The Mode will change to Operation

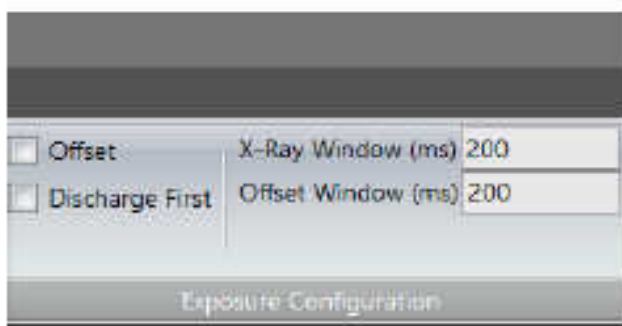
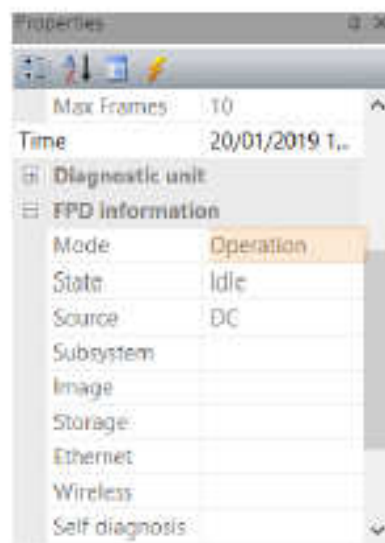

Configure exposure parameters

4.3.5 Performing an Exposure and Image Acquisition

When performing an exposure, make sure that the STATUS LED light in green and not flashing. Otherwise image may loss.

4.3.5.1 AED one shot mode

- After selecting the **AED one shot** mode, press Start.
- When FPD is in **AED one shot** mode, it returns to operation mode after each X-Ray exposure is detected. User can use Stop to exit **AED one shot** mode before X-Ray exposure is detected.
- If the X-Ray exposure is successfully detected by FPD, the newly created image is listed in the Image List area. This utility application will try to download the image to local storage, and the file name is the image key.
- If the working directory is not specified, the images will be saved in the folder as the utility.

4.3.5.2 Software sync mode (Emulation of two-stage exposure button)

INCX

- This group only serves as emulation of two-stage exposure button, and verifies the API functionality.
- After selecting the **Software sync** mode, press Start.
- When performing an exposure, make sure that the STATUS LED light in green and not flashing.

4.3.5.3 AED repeat mode

- After selecting the **AED repeat** mode, press Start.
- When FPD is in **AED repeat** mode, it stays in **AED repeat** mode after each X-Ray exposure is detected. User can use Stop to exit **AED repeat** mode.
- The utility doesn't not download the exposure image after each exposure, it only updates the information of the newly created exposure image in the Image List area.

AED ONE SHOT MODE

Timing Diagram

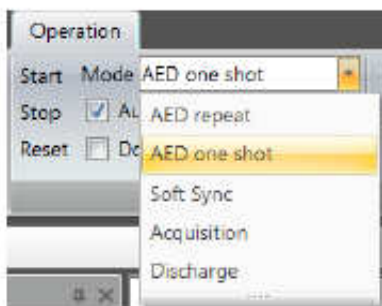
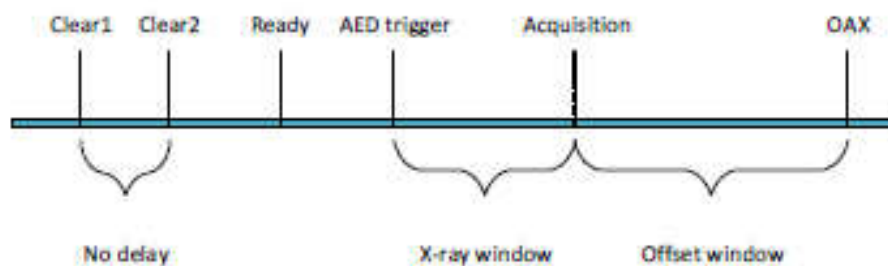

Select AED one shot

And click Start

(Note: After AED one shot operation, user must click Reset to re-enable drop-down menu)

INCX

FPD information	
Mode	AED one shot
State	Ready
Source	DC
Subsystem	Communicatio...

The Mode will change to *AED one shot*.

After State become *Ready*, user can take X-ray exposure.

The Mode enters the AED one shot again after exposure.

FPD information	
Mode	Operation
State	Idle
Source	DC
Subsystem	Communication OK
Image	
Storage	

If the Auto Download is checked, the raw image and offset image (if exists) will be downloaded into folder AED/.

The raw image is displayed in Raw Image Display Area.

User data	Image Key	#	Offset	Time	Status	D/L raw	D/L Offset	D/L Correct.	Mode
A983E42B26E1D5FD2C989649D91B60	001C8C598402E80004EC	2	OK	01/02/2000 00:20:46	Ready	OK	OK		AED
F8A9E829B3AAB8CD387B048030FE94F	001C8C598402E80004EB	1	None	01/02/2000 00:17:15	Ready	OK			AED
1F828788788BA1938FD547556A1021E8	001C8C598402E80004EA	1	None	01/02/2000 00:14:57	Ready	OK			AED

The Status column shows whether the image is ready for downloading.

OK in D/Ls columns means the corresponding images have been downloaded.

4.3.5.4 Other Operations

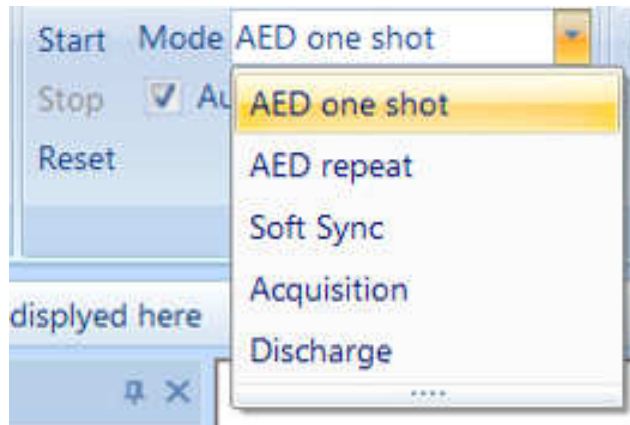

- Discharge: Discharge panel.
- Acquisition: Discharge panel and acquire image immediately.
- Reset operation mode: If errors occur in the exposure workflow, user must use this button to reset.

ACQUISITION MODE

Acquisition mode can take image from FPD without exposure.

Timing Diagram

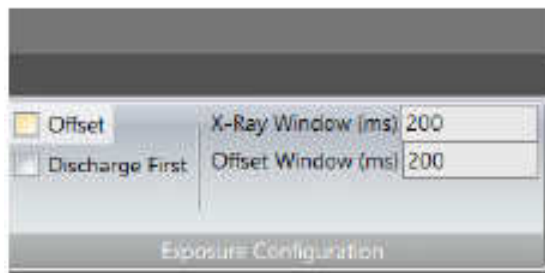
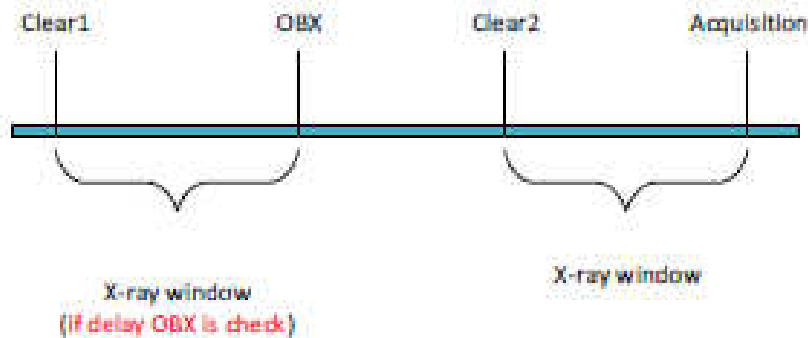

Configure exposure parameters

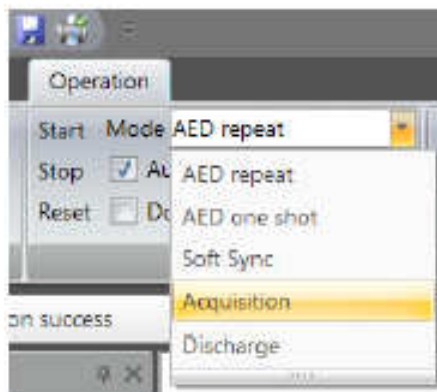

Select Acquisition mode,
and click Start



The Mode changes to *Acquisition* temporarily.

When the Mode returns *Operation*, the image is ready.



If the Auto Download is checked, the raw image and offset image (if exists) will be downloaded into folder **Manual_Acquisition/..**

The raw image is displayed in Raw Image Display Area.

4.3.6 Download image from FPD

- Auto download

The software has an automatic download function, as long as the automatic download is checked, the image can be automatically downloaded in modes other than AED repeat mode.

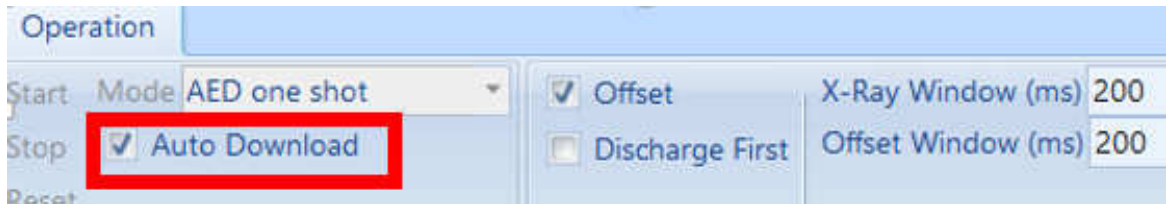

- Image ready

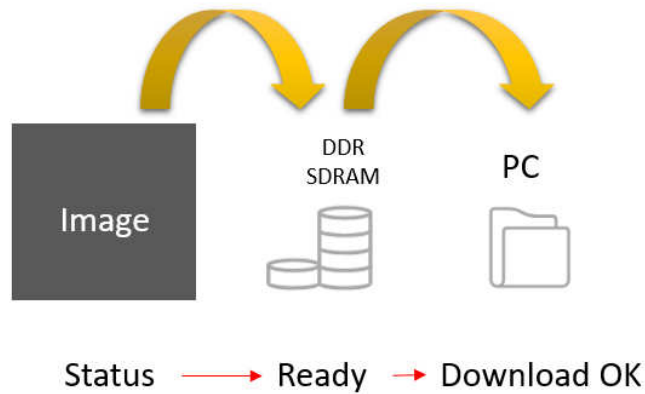

User data	Image Key	#	Offset	Time	Status	D/L ra
D68DFFC67D21111E0EE59C33EC343517	00FFFF0000668D000021	1	None	12/12/2017 05:02:54	Ready	

The image data is first stored in the DDR SDRAM and then transferred to the PC. When the status of image has been show “ready”, it means the images is already stored in the DDR SDRAM.

- Image download OK

User data	Image Key	#	Offset	Time	Status	D/L ra
D68DFFC67D21111E0EE59C33EC343517	00FFFF0000668D000021	1	None	12/12/2017 05:02:54	Ready	OK

When the status of image has been show “OK”, it means the images is already stored in the PC.

- Archive after continuous image taking

If the automatic download function is not checked, the image will be stored in

INCX

the DDR SDRAM. First, press (3) to list all the information of the image, and then press the arrow of (1) to output the original image to the PC. In addition, if there is an image with offset set at the beginning of the exposure, press the (2) arrow to output the offset image to the PC.

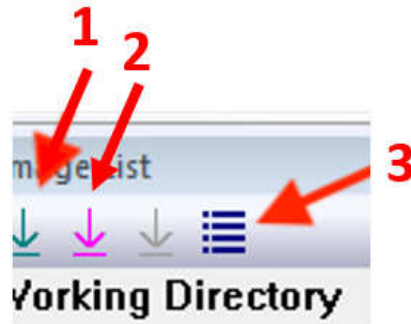

4.3.7 Shutting Down the Yushan

Press the power button for more than 2 second to shut down the FPD.



4.4 Guidelines for Pediatric Applications

InnoCare typically conducts radiologists (Government-certified) usability studies that compare Yushan detector models to the marketed devices. Participate radiologists have demonstrated that the images acquired using the Yushan detectors are deemed to be of diagnostic capability.

Additionally, please review the following scientific literatures regarding pediatric (<https://www.ncbi.nlm.nih.gov/pubmed/29064378>) and neonates (<https://www.ncbi.nlm.nih.gov/pubmed/23086629>). The verification of Yushan detectors are using even lower energy or x-ray voltages to acquire the image, which prove the safety and effectiveness for pediatric and neonates applications. Please refer to the following paragraphs for detailed explanation.

For pediatric, this study has evaluated the physical image quality characteristics of five detectors (2 for CR and 3 for FPD) for paediatric applications, using the IEC RQA5 energy. The results show a clear evolution in detector performance for both the CR and FPD detectors, with physical image quality continuing to improve. In this article, the DQE was evaluated at the normal operating detector air kerma (DAK) level, defined at 2.5 μGy for all detectors. The performance of MTF and DQE for Yushan detectors were all tested and verified at the level of 2.0 μGy , and the test results shows highly sensitivity for image quality.

For neonates, in this study, they investigated the digital characteristics of the digital mobile X-ray imaging system equipped with a new FPD for different tube voltages, and showed that it has an excellent linearity of the digital characteristics and constant contrast characteristics for tube voltages in the range of 50-110 kV. The system can be used for significantly reducing the ESD to neonatal patients (examined by chest X-ray in the NICU) as well as the X-ray system operator exposure more effectively than is available with conventional systems. The physical characterization of the Yushan detectors were obtained with the standard beam conditions RQA5 (in accordance with IEC 61267:1994) with the x-ray tube voltage 70kV.

Furthermore, please review the following link and reduce pediatric technique factors accordingly: <http://www.imagegently.org>

As a general rule, next recommendations shall be observed in pediatrics:

- X-Ray Generator must have short exposures times.

INCX

- For system operation, AEC must be used carefully, preferably use manual technique setting, applying lower doses.
- If possible, use high kVp techniques.

Positioning the pediatric patient: Pediatric patients are not as likely as adults to understand the need to remain still during the procedure. Therefore it makes sense to provide aids to maintaining stable positioning. It is strongly recommended the use of immobilizing devices such as bean bags and restraint systems (foam wedges, adhesive tapes, etc.) to avoid the need of repeating exposures due to the movement of the pediatric patients. Whenever possible use techniques based on the lowest exposure times.

Shielding: We recommend you provide extra shielding of radiosensitive organs or tissues such as eyes, gonads and thyroid glands. Applying a correct collimation will help to protect the patient against excessive radiation as well. Please review the following scientific literature regarding pediatric radiosensitivity: GROSSMAN, Herman. "Radiation Protection in Diagnostic Radiography of Children". *Pediatric Radiology*, Vol. 51, (No. 1): 141--144, January, 1973: <http://pediatrics.aappublications.org/cgi/reprint/51/1/141>.

Technique factors: You should take steps to reduce technique factors to the lowest possible levels consistent with good image acquisition.

For example if your adult abdomen settings are: 70--85 kVp, 200--400 mA, 15--80 mAs, consider starting at 65--75 kVp, 100--160 mA, 2.5--10 mAs for a pediatric patient. Whenever possible use high kVp techniques and large SID (Source Image Distance).

Summary:

- Image only when there is a clear medical benefit.
- Image only the indicated area.
- Use the lowest amount of radiation for adequate imaging based on size of the child (reducing tube output -- kVp and mAs).
- Try to use always short exposure times, large SID values and immobilizing devices.
- Avoid multiple scans and use alternative diagnostic studies (such as ultrasound or MRI) when possible.

4.5 Correction procedure



Cautions

This procedure should only be done by suitably-trained service engineer.



Cautions

If the exposure for the corrected images are collected by wrong exposure setting, for example, (A). Over-exposure than or under-exposure (B). Foreign object is put on the surface (C) collimator of Xray tube is not open to the full field of FPD. It may lead to image artifact.



Cautions

Do not expose to any X-ray during dark image collection.

4.5.1 Collect images

When the program is executed, the corrected images are collected in sequence. First, 16 dark images were collected, then the X-ray energy was set to 20 uGy and the X ray window and offset window were both set to 200 ms and collected 16 times. The LSB average of the light image is obtained. It needs to fall within the range of 15,000 to 20,000. According to the above image, the offset map (D) and the gain map (G) are calculated. And use the following algorithm to correct for raw images.

$$C = \frac{(R - D) * m}{(F - D)} = (R - D) * G$$

- C = corrected image
- R = raw image
- F = flat field image
- D = dark field or dark frame
- m = image-averaged value of (F-D)
- G = Gain = $\frac{m}{(F - D)}$

4.5.2 Correction process

First get 16 dark images and 16 light images, sort and store the images in the same folder, and create another folder named "calib". And store the image to be corrected in the same folder and fill in the name of the folder.

Click " Noise " : The "mode" represents the level of noise. The " ()" represents the number of pixels.

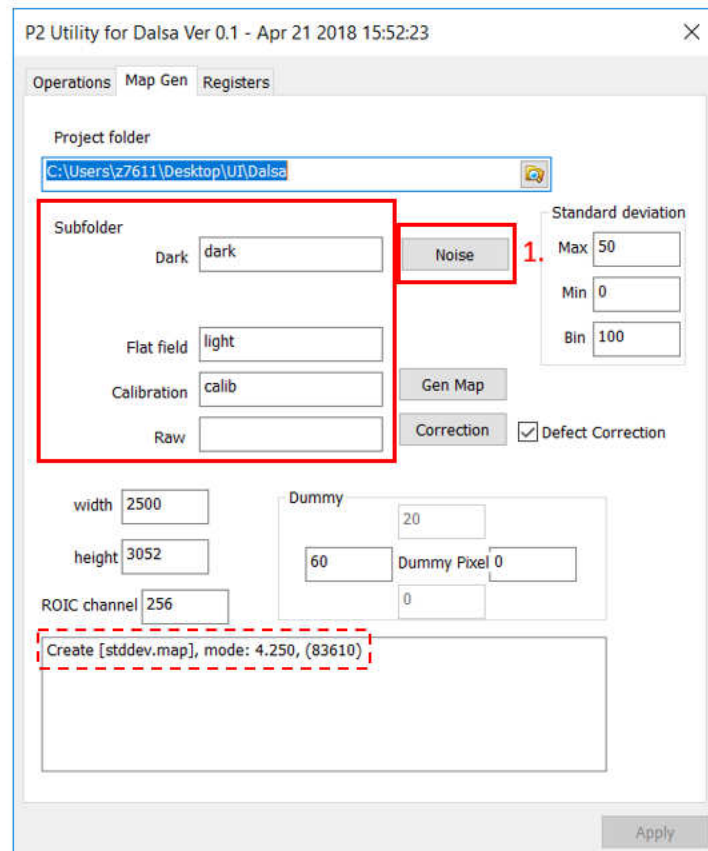

Click “Gen Map”: Will output the map to be calculated

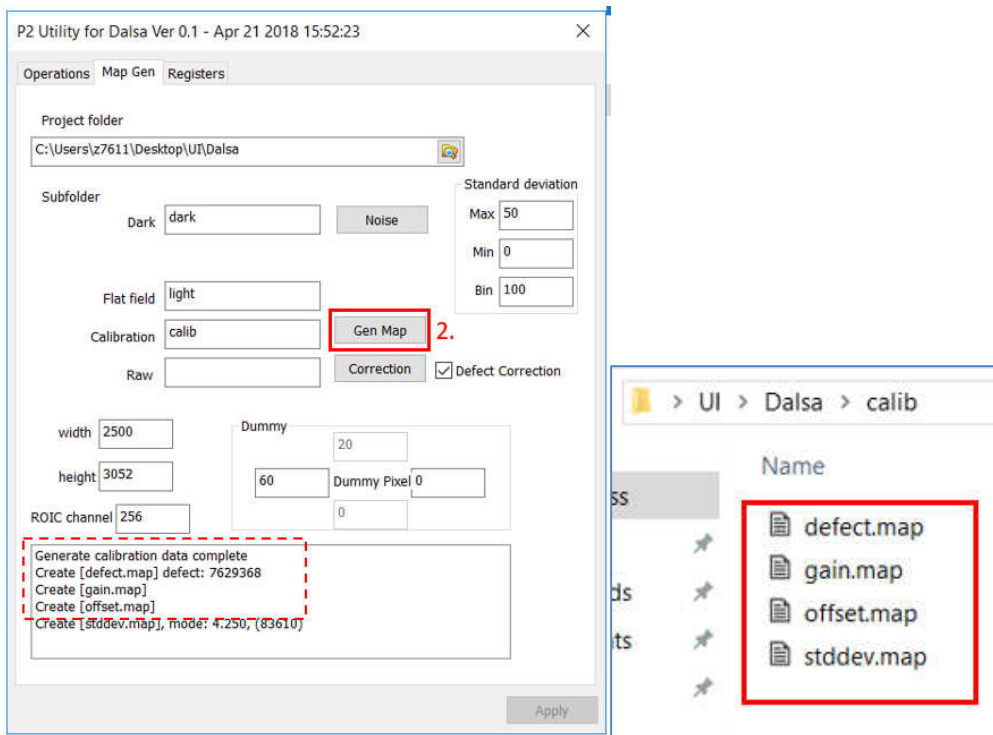

Click “Correction”

The Detector has been successfully corrected if a “correction of all raw images is complete” appears in the windows as seen in the figure.

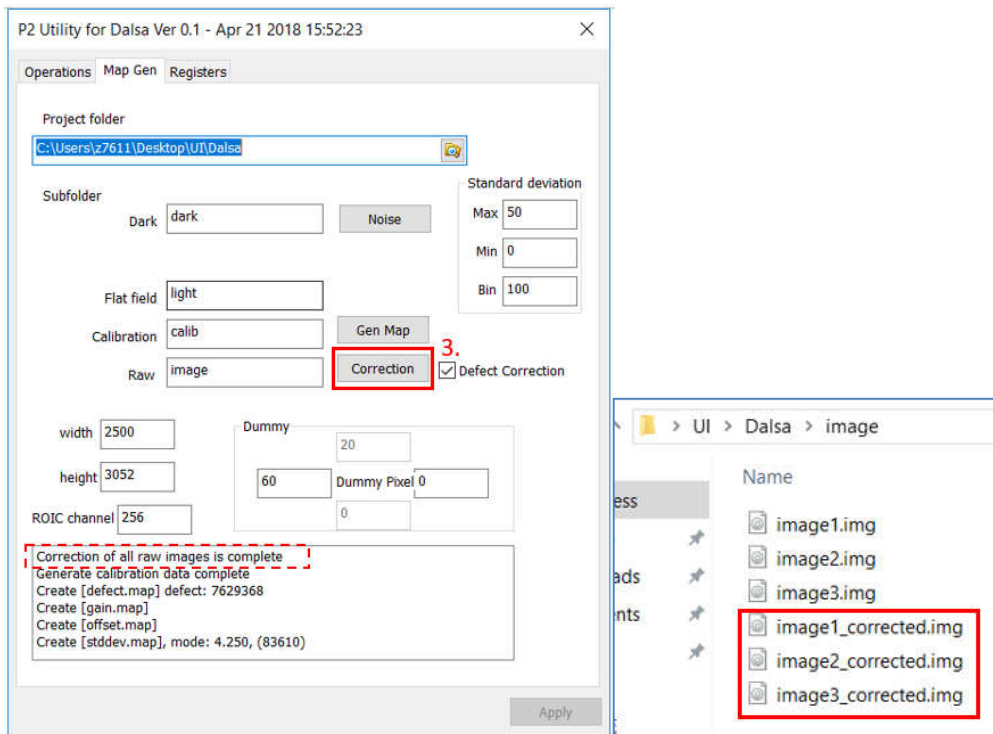

4.5.3 Storage of calibration data

10 sets of calibration data can be stored inside Yushan. Users can update or get calibration data for the product.

After selecting the class of the map, click “File to send”. Click on the file to be updated to the inside of the product.

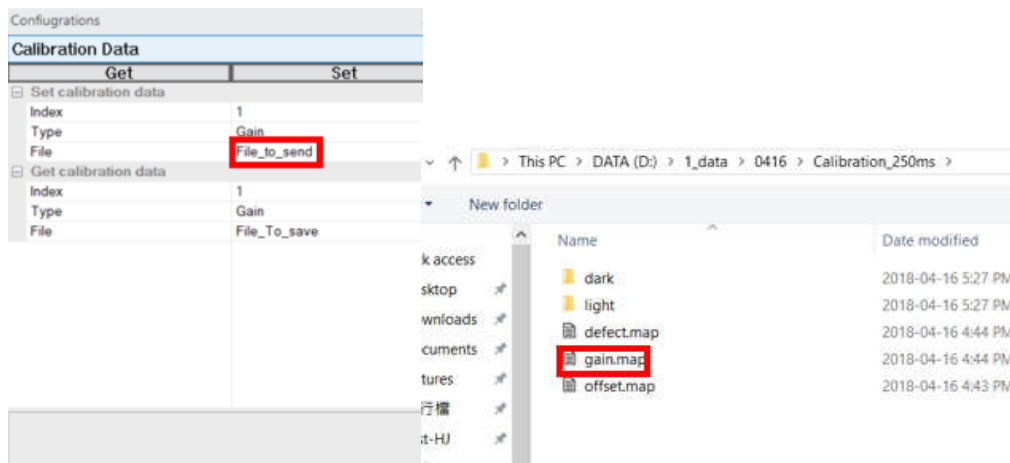

Click “Set” and complete the update.

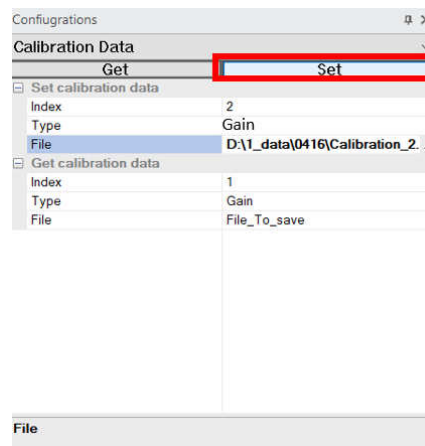

These actions are carried out by Authorized Personnels not End Users.

4.5.4 Standard Configuration

A. Other Essential System Components necessary to perform Digital Radiography

- Yushan (Supporting SDK Interface) can be used in combination with the image processing unit provided by System Integrator.
- The X-ray equipment is composed of X-ray high voltage generator and X-ray console, etc. The hand switch is connected with the console for the exposure. At first, when making an exposure, press the Prep switch only of the hand switch. After confirming that the X-ray equipment is ready System Integrator of X-rays, press the Exp. switch of the hand switch.
- The Access Point is required system, when Yushan is used in wireless communication mode.

B. A standard configuration of this device is as below.

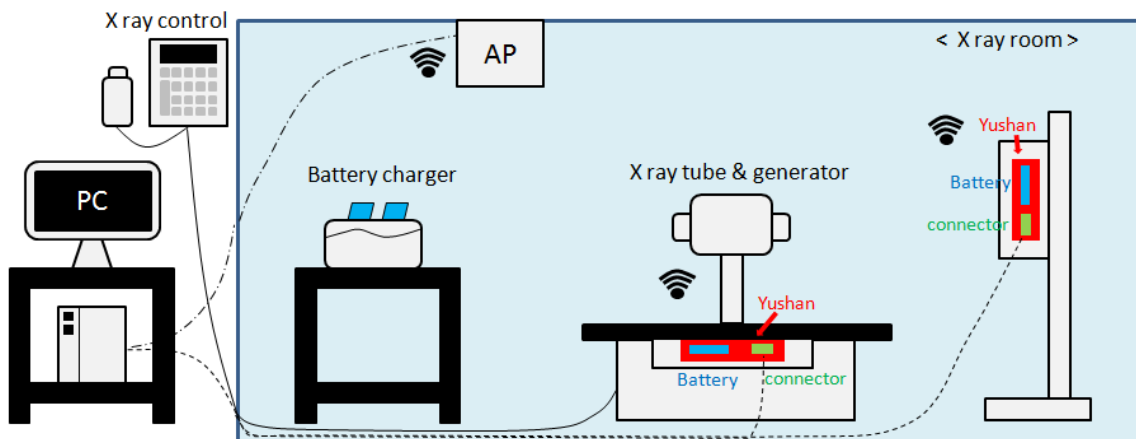

- Yushan (Supporting SDK Interface):

Flat panel sensor : Yushan V14C / V14G / V17C / V17G

The control software is installed and used in a Windows PC (the image processing unit) prepared by the System Integrator.

This variation provides images, which diagnostic image process is not implemented, to the image processing unit.

An X-ray automatic detection function is used for Yushan V14C / V14G / V17C / V17G. This function could detect a start timing of an X-ray exposure using readout signals in the detector. After detecting the start timing of the X-ray exposure, the detector starts collecting of X-ray signals and image readout.

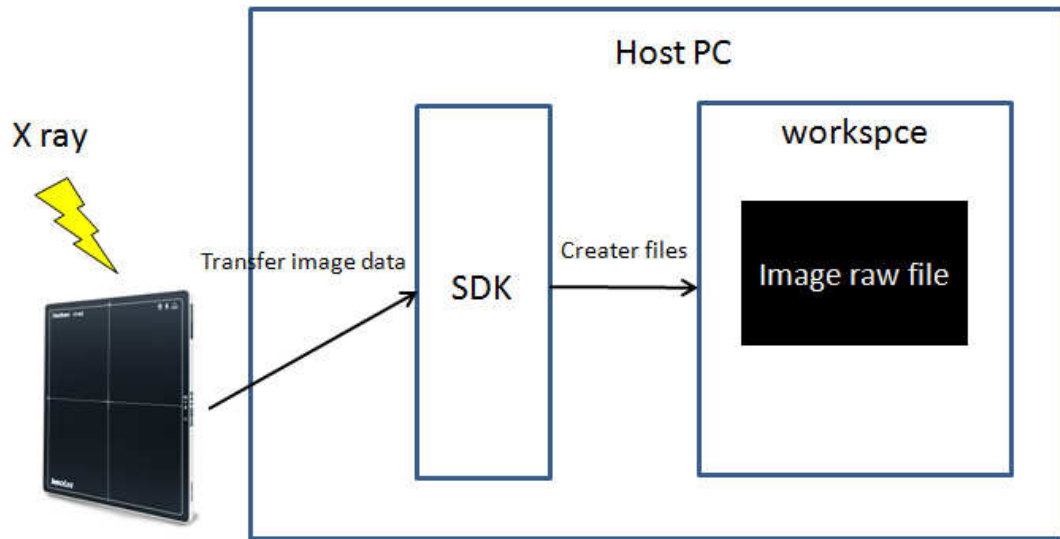

- Transfer image data generated by Yushan to the memory within Host PC
- Generate an image file and information file.
- Yushan only provides raw file to system vendors.

Chapter 5 Daily Inspection and Maintenance

5.1 Daily User Inspection and Maintenance

During maintenance and inspection, strictly observe precautions contained in “Chapter 2 Safety and Regulatory” in this manual for you to use the device under best conditions.

5.1.1 Periodical Inspection

End User	
Remove any dirt or dust accumulated in each part of the equipment using a vacuum cleaner or air duster, clean each part with a slightly moistened soft cloth and then wipe off any moisture with a dry cloth. See “3.2 Unit Names and the Functions”.	Every Three Months
Authorized Personnel	
There are no parts/components that needed to be replaced by InnoCare or any authorized personnel.	



Be sure to turn off the power before cleaning each part of the device.

Ensure sufficient space when cleaning the equipment on a table, etc.



Chapter 6 Troubleshooting

- In case of smoke, fire, abnormal high temperature, remove battery and power supply and turn off detector immediately.
- In case of yellow error LED on, it may trigger the impact. Please read the manual to release the status and restart the power; if the yellow light cannot be removed, contact InnoCare service engineer or local representative
- In case of abnormal image, calibrate detector by standard method. Contact InnoCare service engineer or local representative if error is not removed by calibration.
- Other technical issue, contact InnoCare service engineer or local representative.
- When Yushan cannot be turned on, please check if the battery has power or if the DC power supply is connected.
- When the software shows that the network can't connect, please confirm the signal of Yushan first. If it is wireless network, the third light needs to be solid green to indicate that it has been connected. If the green light flashes, it means that Yushan is not connected. At this time, please check the network settings of the environment and the computer, and have successfully connected.

Appendix A Specifications of FPD

A.1 Specifications

Specifications of the Yushan are shown below.

A.1.1 Reduced Equivalent

Peak reduced equivalent on the front panel of the flat panel detector: 0.57 mmAl

A.1.2 Power Supply Conditions when Using Back-up

Cable

The DC power supply to Yushan FPD is delivered with its AC/DC adapter.

Item	Min	Typ.	Max	unit
Input Voltage Range	80		264	VAC
Nominal Input Frequency	50		60	hz
Input Frequency Range	47		63	hz
Output voltage		24		VDC
Output current			2.5	A
Input connector (AC inlet)		Standard IEC 62320-C14		
Output connector type		DC JACK 5525		

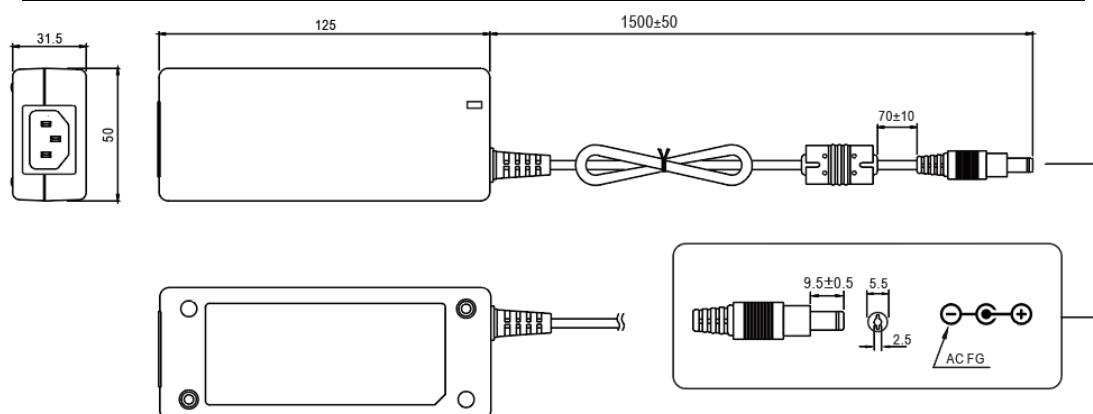

A.1.3 Power Supply to Battery Charger

A 2-slot battery charger is provided along with the Yushan V14C/V14G/V17C/V17G.

The battery charger is delivered with its AC/DC adapter which is the same as A.1.2.

A.1.4 Power Consumption and Battery Specification

Item	Specification (typical)	Unit
Power (Operating)	16	W
Power (Stand-by)	10	W
Battery voltage	11.4	V
Battery capacity	4212	mAh
Battery operating time in stand-by mode	6	hours
Battery operating time in Operating mode	4	hours
Charging time (by cable)	4	hours

A.1.5 Environmental Conditions

A.1.5.1 Storage and Transport

Item	Min	Max
Temperature	-10℃	50℃
Humidity ¹	10%	90%
Pressure ²	700mBar	1060mBar
Battery storage temperature ³	-10℃	50℃

- note1: Non-condensing
- note2: 700mBar is equivalent to 3000m in altitude
- note3: Less than 1 month at 50℃

A.1.5.2 Functional Operating

Within the range of functional operating conditions, the Yushan V14C/V14G/V17C/V17G are safe and functional.

Functional means that the detector is able to deliver an image, whereas the



image quality and electro-optical performances are not guaranteed. It also means that, except if mentioned explicitly, any perturbation occurring within those conditions are reversible and not existing anymore when the detector is turned back within the performance operating conditions.

Item	Min	Typ.	Max
Temperature	5°C	25°C	35°C
Humidity	15%		80%
Pressure	700mBar	1013mBar	1060mBar
Weight (uniform load)			300 kg
Weight (local load on 4 cm diameter)			120 kg
Vibrations (10 -200 Hz / 3 axis)			2 g
Drop height (the reversibility to full performance is not guaranteed for this item)			70 cm

A.1.5.3 Performance Operating

Performance is guaranteed in the operating range below.

Item	Min.	Typ.	Max.
Temperature	15°C	25°C	30°C
Humidity	15%		80%
Pressure	700mBar	1013mBar	1060mBar
Distance to calibration temperature	-12°C	0°C	+12°C
Weight (uniform load)			300 kg
Weight (local load on 4 cm diameter disc)			120 kg
Vibrations (10 -200 Hz / 3 axis)			2 g
Drop (The Yushan V14C/V14G/V17C/V17G remains at full performance after a drop test of following height)			70 cm



Caution

When the flat panel detector is used in high temperature condition for long period of time, it may cause image artifacts and/or failure of the device.

A.1.6 Image Performance

The testing measurement procedure of MTF and DQE is complies with IEC 62220-1 (MEDICAL ELECTRICAL EQUIPMENT - CHARACTERISTICS OF DIGITAL X-RAY IMAGING DEVICES) as a general X-ray radiography equipment.

To ensure optimal image quality, it is recommended that you do not use the flat panel detector near devices (motor, transformer, switching supply, etc.) that generate electromagnetic noise.

V14C/V17C (Csl Version) Performance at *RQA5

Item	Min	Typ.	Max	unit
MTF @ 1 lp / mm	0.62	0.69	0.76	
MTF @ 2 lp / mm	0.31	0.39	0.47	
MTF @ 3 lp / mm	0.15	0.22	0.28	
DQE @ 0.5 lp / mm	0.42	0.51	0.60	
DQE @ 1 lp / mm	0.40	0.48	0.55	
DQE @ 2 lp / mm	0.31	0.39	0.47	
DQE @ 3 lp / mm	0.20	0.29	0.37	
Sensitivity @2uGy	488	574	660	LSB/uGy
Dark noise		4.5	6	LSB
Maximun linear dose	75	88	101	uGy
Maximun clipping dose	100	120	140	uGy
Energy range	40		150	KVp
Max. resolution			3.57	lp/mm

V14C/V17C (Csl Version) Life Time Performance at

***RQA5**

Item	Min	Typ.	Max	unit
MTF @ 1 lp / mm	0.55	0.69		
MTF @ 2 lp / mm	0.27	0.39		
MTF @ 3 lp / mm	0.13	0.22		
DQE @ 0.5 lp / mm	0.38	0.51		
DQE @ 1 lp / mm	0.36	0.48		
DQE @ 2 lp / mm	0.29	0.39		
DQE @ 3 lp / mm	0.19	0.29		

V14G/V17G (GOS Version) Performance at *RQA5

Item	Min	Typ.	Max	unit
MTF @ 1 lp / mm	0.46	0.52	0.57	
MTF @ 2 lp / mm	0.18	0.23	0.28	
MTF @ 3 lp / mm	0.08	0.11	0.14	
DQE @ 0.5 lp / mm	0.25	0.31	0.37	
DQE @ 1 lp / mm	0.23	0.27	0.32	
DQE @ 2 lp / mm	0.13	0.16	0.20	
DQE @ 3 lp / mm	0.07	0.09	0.12	
Sensitivity @2uGy	503	592	681	LSB/uGy
Dark noise		7.9	10	LSB
Maximun linear dose	75	88	101	uGy
Maximun clipping dose	100	120	140	uGy
Energy range	40		150	KVp
Max. resolution			3.57	lp/mm

V14G/V17G (GOS Version) Life Time Performance at

***RQA5**

Item	Min	Typ.	Max	unit
MTF @ 1 lp / mm	0.44	0.52		
MTF @ 2 lp / mm	0.17	0.23		
MTF @ 3 lp / mm	0.07	0.11		
DQE @ 0.5 lp / mm	0.23	0.31		
DQE @ 1 lp / mm	0.22	0.27		
DQE @ 2 lp / mm	0.12	0.16		

DQE @ 3 lp / mm	0.06	0.09		
-----------------	------	------	--	--

***The above specifications have been verified by INCX; The physical characterization of the systems was obtained with the standard beam conditions RQA5 (in accordance with IEC 61267:1994).**

A.1.7 Radio Waves

Wireless specifications for the flat panel detector and the access point are as follows.

Item	Specification
Wireless specification	IEEE802.11 ac / a/g/n
Transmit frequency	5.2, 5.3, 5.6, 2.4 GHz
Antenna	2
Date rate	866Mbps (802.11ac)
Authentication	WPA/WPA2-PSK
AP mode	Work only in 2.4Ghz

- Note: Use of 2.4GHz: ch11 for N.America, ch13 for Europe (ETSI)
- Transmit frequencies available vary, depending on the country.
- Radio waves available outdoors vary, depending on the country where the system is used.
- When the Yushan and any other wireless equipment are operating on the same frequency channel in a hospital, it may take time to show an image on the image processing unit monitor.
- This equipment uses wireless LAN (WLAN) radios for transferring images. The WLAN power levels and antenna configurations have been tested and certified compliant through specific absorption rate (SAR) limit set by FCC testing with separations as small as 0 cm between the panel antennas and human tissue.

A.1.8 Reliability and Lifetime

Item	Specification	unit
X-ray hardness	100	Gy
Expect service life	10	years

A.2 External View and Weight

Item	Width	Length (mm)	Height (mm)	Weight (Kg)
Yushan V14C	460	383	15	2.7
Yushan V14G	460	383	15	2.7
Yushan V17C	460	460	15	3.1
Yushan V17G	460	460	15	3.2

Yushan V14 series

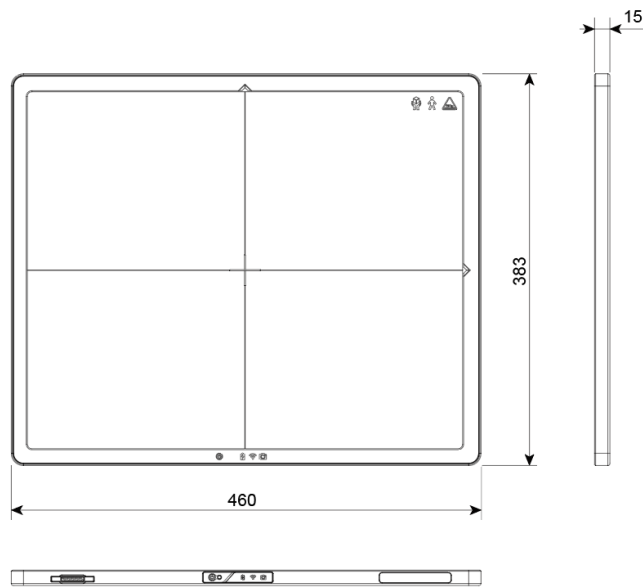

Yushan V17 series

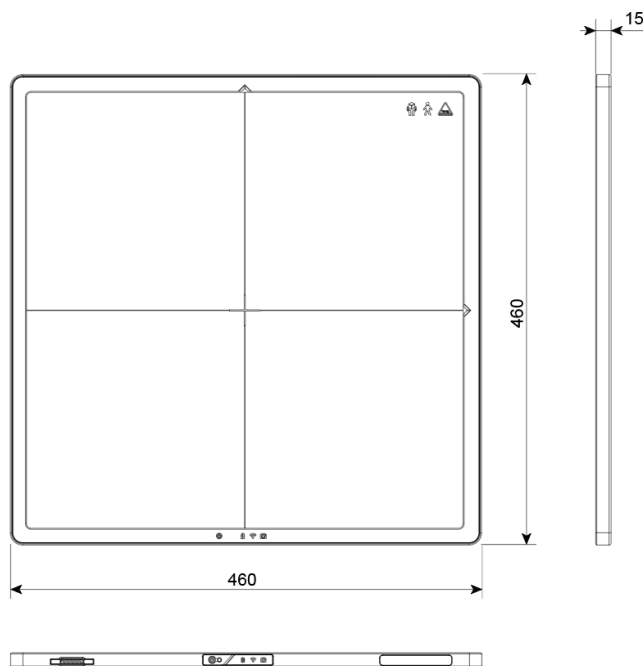

Unit : mm



Appendix B Electromagnetic Compatibility (EMC)

B.1 Yushan FPD

This equipment has been tested and found to comply with the limits for medical devices to the IEC 60601-1-2:2014/EN 60601-1-2:2015.

These limits are designed to provide reasonable protection against harmful interference in a typical medical installation.

This equipment generates, uses and can radiate radio frequency energy and, if not installed and used in accordance with the instructions, may cause harmful interference to other devices in the vicinity.

However, there is no guarantee that interference will not occur in a particular installation.

If this equipment does cause harmful interference to other devices, which can be determined by tuning the equipment off and on, the user is encouraged to try to correct the interference by one or more of the following measures:

- Reorient or relocate the receiving device.
- Increase the separation between the equipment.
- Connect the equipment into an outlet on a circuit different from that to which the other device(s) are connected.

If the problem cannot be solved with the above measures, stop using this equipment and consult the manufacturer, our official dealer or InnoCare Representative for help.



Warning

Do not place devices generating electromagnetic wave near this equipment.

If a device(s) other than those specified is connected, predetermined EMC performance can not be guaranteed.

B.2 Further Information for IEC 60601-1-2 (EN 60601-1-2)



This equipment is not intended for use in residential environments and may not provide adequate protection to radio reception in such environments.

1. Medical electrical equipment needs special precautions regarding EMC and needs to be installed and put into service according to the EMC information provided in the accompanying documents.

2. Portable and mobile RF communications equipment can affect medical electrical equipment.

3. Information regarding the cable affecting EMC is as follows.

Name	Connection	Maximum length	General specification
Network cable	Extend Back-up cable to PC or network switch.	20m	Cat 5e or more UTP type and straight cable
Power cord	From adaptor to AC outlet	Use a hospital grade power cord	

4. The use of accessories, transducers and cables other than those specified, with the exception of transducers and cables sold by InnoCare Optoelectronics Corp. as replacement parts for internal components, may result in increased emissions or decreased immunity of the Yushan.

5. The Yushan should not be used adjacent to or stacked with other equipment.

If adjacent or stacked use is necessary, the Yushan FPD should be observed to verify normal operation in the configuration in which it will be used.

6. Basic performance of the equipment and the system



After image data are acquired from the flat panel detector, offset data correction is performed by flat pane detector and then the image is send to DR system via wireless connection or wired connection.

7. Test items

Manufacturer's declaration-electromagnetic emissions		
<p>The <u>Yushan V14C, Yushan V14G</u> is intended for use in the electromagnetic environment (for professional healthcare) specified below.</p> <p>The customer or the user of the <u>Yushan V14C, Yushan V14G</u> should assure that it is used in such an environment.</p>		
Emission test	Compliance	Electromagnetic environment-guidance (for professional healthcare environment)
RF emissions CISPR 11	Group 1	The <u>Yushan V14C, Yushan V14G</u> uses RF energy only for its internal function. Therefore, its RF emissions are very low and are not likely to cause any interference in nearby electronic equipment.
RF emissions CISPR 11	Class A	The <u>Yushan V14C, Yushan V14G</u> is suitable for use in all establishments other than domestic and those directly connected to the public low-voltage power supply network that supplies buildings used for domestic purposes.
Harmonic emissions IEC 61000-3-2	Not applicable	
Voltage fluctuations /flicker emissions IEC 61000-3-3	Compliance	

Manufacturer's declaration-electromagnetic immunity			
<p>The <u>Yushan V14C, Yushan V14G</u> is intended for use in the electromagnetic environment (for professional healthcare) specified below.</p> <p>The customer or the user of the <u>Yushan V14C, Yushan V14G</u> should assure that it is used in such an environment.</p>			
Immunity test	IEC 60601 test level	Compliance level	Electromagnetic environment-guidance (for professional

INCX

			healthcare environment)
Electrostatic discharge(ESD) IEC 61000-4-2	Contact:±8 kV Air±2 kV,±4 kV,±8 kV,±15 kV	Contact:±8 kV Air±2 kV,±4 kV,±8 kV,±15 kV	Floors should be wood, concrete or ceramic tile. If floors are covered with synthetic material, the relative humidity should be at least 30%
Electrical fast transient/burst IEC 61000-4-4	± 2kV for power supply lines ± 1kV for input/output lines	± 2kV for power supply lines ± 1kV for input/output lines	Mains power quality should be that of a typical professional healthcare environment.
Surge IEC 61000-4-5	± 0.5kV, ±1kV line(s) to line(s) ± 0.5kV, ±1kV,± 2kV line(s) to earth	± 0.5kV, ±1kV line(s) to line(s) ± 0.5kV, ±1kV,± 2kV line(s) to earth	Mains power quality should be that of a typical professional healthcare environment.
Voltage Dips, short interruptions and voltage variations on power supply input lines IEC 61000-4-11	Voltage dips: 0 % U_T ; 0,5 cycle 0 % U_T ; 1 cycle 70 % U_T ; 25/30 cycles Voltage interruptions: 0 % U_T ; 250/300 cycle	Voltage dips: 0 % U_T ; 0,5 cycle 0 % U_T ; 1 cycle 70 % U_T ; 25 cycles Voltage interruptions: 0 % U_T ; 250 cycle	Mains power quality should be that of a typical professional healthcare environment. If the user of the <u>Yushan V14C, Yushan V14G</u> requires continued operation during power mains interruptions, it is recommended that the <u>Yushan V14C, Yushan V14G</u> be powered from an uninterruptible power supply or a battery.
Power frequency(50, 60 Hz) magnetic field IEC 61000-4-8	30 A/m 50 Hz or 60 Hz	30 A/m 50 Hz	The <u>Yushan V14C, Yushan V14G</u> power frequency magnetic fields should be at levels characteristic of a typical location in a typical professional healthcare

environment.

NOTE UT is the a.c. mains voltage prior to application of the test level.

Manufacturer's declaration-electromagnetic immunity

The Yushan V14C, Yushan V14G is intended for use in the electromagnetic environment (for professional healthcare) specified below.

The customer or the user of the Yushan V14C, Yushan V14G should assure that it is used in such and environment.

Immunity test	IEC 60601 test level	Compliance level	Electromagnetic environment-guidance (for professional healthcare environment)
Conducted RF IEC 61000-4-6	3 Vrms: 0,15 MHz – 80 MHz 6 Vrms: in ISM bands between 0,15 MHz and 80 MHz	3 Vrms: 0,15 MHz – 80 MHz 6 Vrms: in ISM bands between 0,15 MHz and 80 MHz	Portable and mobile RF communications equipment should be used no closer to any part of the <u>Yushan V14C, Yushan V14G</u> including cables, than the recommended separation distance calculated from the equation applicable to the frequency of the transmitter.
Radiated RF IEC 61000-4-3	80 % AM at 1 kHz 3 V/m 80 MHz – 2,7 GHz 80 % AM at 1 kHz	80 % AM at 1 kHz e) 3 V/m 80 MHz – 2,7 GHz 80 % AM at 1 kHz	Recommended separation distance: $d = 1,2 \sqrt{P}$ $d = 1,2 \sqrt{P}$ 80MHz to 800 MHz $d = 2,3 \sqrt{P}$ 800MHz to 2,7 GHz Where P is the maximum output power rating of the transmitter in watts (W) according to the transmitter manufacturer and d is the recommended separation distance in metres (m). Interference may occur in the vicinity of equipment marked with the following symbol:



NOTE1 At 80 MHz and 800 MHz, the higher frequency range applies.

NOTE2 These guidelines may not apply in all situations. Electromagnetic propagation is affected by absorption and reflection from structures, objects and people.

Recommended separation distance between portable and mobile RF communications equipment and the Yushan V14C, Yushan V14G

The Yushan V14C, Yushan V14G is intended for use in an electromagnetic environment (for professional healthcare) in which radiated RF disturbances are controlled. The customer or the user of the Yushan V14C, Yushan V14G can help prevent electromagnetic interference by maintaining a minimum distance between portable and mobile RF communications equipment (transmitters) and the Yushan V14C, Yushan V14G as recommended below, according to the maximum output power of the communications equipment.

Rated maximum output power of transmitter W	Separation distance according to frequency of transmitter m		
	150 kHz to 80 MHz $d = 1,2\sqrt{P}$	80 MHz to 800 MHz $d = 1,2\sqrt{P}$	800 MHz to 2,7 GHz $d = 2,3\sqrt{P}$
0,01	0,12	0,12	0,23
0,1	0,38	0,38	0,73
1	1,2	1,2	2,3
10	3,8	3,8	7,3
100	12	12	23

For transmitters rated at a maximum output power not listed above, the recommended separation distance d in meters (m) can be estimated using the equation applicable to the frequency of the transmitter, where p is the maximum output power rating of the transmitter in watts (W) according to the transmitter manufacturer.

NOTE1 At 80 MHz and 800 MHz, the separation distance for the higher frequency range applies.

NOTE2 These guidelines may not apply in all situations. Electromagnetic propagation is affected by absorption and reflection from structures, objects and people.



Manufacturer's declaration-electromagnetic immunity

Test specifications for ENCLOSURE PORT IMMUNITY to RF wireless communications equipment

The Yushan V14C, Yushan V14G is intended for use in the electromagnetic environment (for professional healthcare) specified below.

The customer or the user of the Yushan V14C, Yushan V14G should assure that it is used in such an environment.

Test frequency (MHz)	Band ^{a)} (MHz)	Service ^{a)}	Modulation ^{b)}	Maximum power (W)	Distance (m)	IMMUNITY TEST LEVEL (V/m)	Compliance LEVEL (V/m) (for professional healthcare)
385	380 – 390	TETRA 400	Pulse modulation b)18 Hz	1,8	0,3	27	27
450	430 – 470	GMRS 460, FRS 460	FM c)±5 kHz deviation 1 kHz sine	2	0,3	28	28
710	704 – 787	LTE Band 13, 17	Pulse modulation b) 217 Hz	0,2	0,3	9	9
745							
780							
810	800 – 960	GSM 800/900, TETRA 800, iDEN 820, CDMA 850, LTE Band 5	Pulse modulation b) 18 Hz	2	0,3	28	28
870							
930							

1 720	1 700 – 1 990	GSM 1800; CDMA 1900; GSM 1900; DECT; LTE Band 1, 3, 4, 25; UMTS	Pulse modulation b) 217 Hz	2	0,3	28	28
1 845							
1 970							
2 450	2 400 – 2 570	Bluetooth, WLAN, 802.11 b/g/n, RFID 2450, LTE Band 7	Pulse modulation b) 217 Hz	2	0,3	28	28
5 240	5 100 – 5 800	WLAN 802.11 a/n	Pulse modulation b) 217 Hz	0,2	0,3	9	9
5 500							
5 785							

NOTE If necessary to achieve the IMMUNITY TEST LEVEL, the distance between the transmitting antenna and the ME EQUIPMENT or ME SYSTEM may be reduced to 1 m. The 1 m test distance is permitted by IEC 61000-4-3.

- a) For some services, only the uplink frequencies are included.
- b) The carrier shall be modulated using a 50 % duty cycle square wave signal.
- c) As an alternative to FM modulation, 50 % pulse modulation at 18 Hz may be used because while it does not represent actual modulation, it would be worst case.



Appendix C Radio Frequency (RF) Compliance Information

1. For U.S.A. and Canada

Federal Communications Commission (FCC) Statement

You are cautioned that changes or modifications not expressly approved by the part responsible for compliance could void the user's authority to operate the equipment.

This equipment has been tested and found to comply with the limits for a Class B digital device, pursuant to part 15 of the FCC rules. These limits are designed to provide reasonable protection against harmful interference in a residential installation. This equipment generates, uses and can radiate radio frequency energy and, if not installed and used in accordance with the instructions, may cause harmful interference to radio communications. However, there is no guarantee that interference will not occur in a particular installation. If this equipment does cause harmful interference to radio or television reception, which can be determined by turning the equipment off and on, the user is encouraged to try to correct the interference by one or more of the following measures:

- Reorient or relocate the receiving antenna.
- Increase the separation between the equipment and receiver.
- Connect the equipment into an outlet on a circuit different from that to which the receiver is connected.
- Consult the dealer or an experienced radio/TV technician for help.

This device complies with Part 15 of the FCC Rules. Operation is subject to the following two conditions:

- 1) this device may not cause harmful interference and
- 2) this device must accept any interference received, including interference that may cause undesired operation of the device.

FCC RF Radiation Exposure Statement:

1. This Transmitter must not be co-located or operating in conjunction with any other antenna or transmitter.
2. This equipment complies with RF radiation exposure limits set forth for an



uncontrolled environment. This equipment should be installed and operated with a minimum distance of 0 cm between the radiator and your body.

2. For European Union and EEA-EFTA

Requirements in AT/BE/BG/CZ/DK/EE/FR/DE/IS/IE/IT/EL/ES/CY/LV/LI/LT/LU/HU/MT/NL/NO/PL/PT/RO/SI/SK/TR/FI/SE/CH/UK/HR. 5150MHz~5350MHz is for indoor use only.

SAR is measured with the device at 0 mm to the body, while transmitting at the highest certified output power level in all frequency bands of the device. The maximum SAR value is 1.7 W/kg (head/body) averaged over 10 gram of tissue.

This equipment should be installed and operated with a minimum distance of 0 cm between the radiator and your body

Note:

Member State abbreviation as below:

Belgium (BE), Bulgaria (BG), Czech Republic (CZ), Denmark (DK), Germany (DE), Estonia (EE), Ireland (IE), Greece (EL), Spain (ES), France (FR), Croatia (HR), Italy (IT), Cyprus (CY), Latvia (LV), Lithuania (LT), Luxembourg (LU), Hungary (HU), Malta (MT), Netherlands (NL), Austria (AT), Poland (PL), Portugal (PT), Romania (RO), Slovenia (SI), Slovakia (SK), Finland (FI), Sweden (SE) and United Kingdom (UK).

EEA-EFTA abbreviation as below:

Iceland (IS), Norway (NO), Liechtenstein (LI), Switzerland (CH).

.

Declaration of Conformity to RED

For the following equipment:	Flat Panel Detector								
Product name:	Yushan series (V14C, V14G)								
Manufacturer:	InnoCare Optoelectronics Corp.								
Address:	Rm. B, No. 2, Sec. 2, Huanxi Rd., Xinshi Dist., Tainan City 744, Taiwan (R.O.C.)								
Authorized Representative:	Innolux Europe B.V.								
Address:	Stationstraat 39-G 6411 NK Heerlen, The Netherlands								
GMDN Code:	37645								
Classification (MDD, Annex IX):	Class IIa (Rule 16)								
<p>We, InnoCare Optoelectronics Corp., hereby declare under our sole responsibility that the product(s) identified in this declaration conforms to the provisions of the following Directive and Standards.</p> <p>Directive: The Radio Equipment Directive 2014/53/EU (RED)</p> <p>Standards:</p> <table> <tr> <td>Health</td> <td>EN 62479:2010</td> </tr> <tr> <td>Radio</td> <td>EN 300 328 V2.1.1 EN 301 893 V2.1.1</td> </tr> <tr> <td>EMC</td> <td>EN 301 489-1 V2.2.0 EN 301 489-17 V3.2.0 EN 60601-1-2:2015</td> </tr> <tr> <td>Safety</td> <td>EN 60601-1:2006+A1:2013+A12:2014</td> </tr> </table>		Health	EN 62479:2010	Radio	EN 300 328 V2.1.1 EN 301 893 V2.1.1	EMC	EN 301 489-1 V2.2.0 EN 301 489-17 V3.2.0 EN 60601-1-2:2015	Safety	EN 60601-1:2006+A1:2013+A12:2014
Health	EN 62479:2010								
Radio	EN 300 328 V2.1.1 EN 301 893 V2.1.1								
EMC	EN 301 489-1 V2.2.0 EN 301 489-17 V3.2.0 EN 60601-1-2:2015								
Safety	EN 60601-1:2006+A1:2013+A12:2014								

Signed for and on behalf of InnoCare Optoelectronics Corp.		
Place and date:	Eric Lee	Signature:
Tainan May, 2019	President	

INCX

INCX



Manufacturer

InnoCare Optoelectronics Corp.

Rm. B, No. 2, Sec. 2, Huanxi Rd.,
Southern Taiwan Science Park, Xinsi Dist.,
Tainan City 741, Taiwan (R.O.C.)



European Authorized Representative:

Innolux Europe B.V.
Stationstraat 39-G, 6411 NK Heerlen, The Netherlands