

QualConnex On-Line Transformer Monitor Installation & User Guide

DGALT1-11120, DGA-LT1

GTW-RF-3311, QGateway, USA

GTW-RF-3311-CA, QGateway, Canada

Version: 2.0: July 2022

Information in this document is subject to change without notice. This document is provided to purchasers or users of Qualitrol products for use in the installation, operation, and servicing of such products. No other use, nor any reproduction, distribution, or the making of any derivatives of this document is authorized, without the express prior written permission of Qualitrol Corporation.

Qualitrol endeavors to ensure the accuracy and quality of its published materials; however, no warranty, expressed or implied, is provided. Qualitrol disclaims any responsibility or liability for any direct or indirect damage resulting from the use of the information in this manual or products described in it. The mention of any product or brand does not constitute an endorsement by Qualitrol of that product or brand.

This document was originally composed in English and was subsequently translated into other languages. The fidelity of subsequent translations cannot be guaranteed. In case of conflict between the English version and another language version, the English version takes precedence.

© 2022 Qualitrol Corporation. 1385 Fairport Rd, Fairport, NY 14450. All rights reserved. Information subject to change without notice.

QUALITROL, DGA-LT1, QualConnex and QGateway are registered trademarks of Qualitrol Corporation

Contents

Table of Contents

Product Overview	3
DGA-LT1	3
QGateway	4
QualConnex® Web Application	4
Symbols	4
Product Specifications	5
Environmental Specifications	5
DGA LT1 Specifications	5
QGateway Specifications	5
Site Preparation	6
Verify DGA-LT1 Clearance and Drain size	6
Transformer Selection	7
Transformer Configuration	7
Transformer Distance Evaluation.....	7
Transformer Elevation Evaluation.....	8
Line of Sight – Obstruction Evaluation.....	8
Cell Coverage Evaluation	8
QGateway Quantity and Location.....	8
Transformer Details to Prepare for Installation	10
Monitor Installation	11
Items Shipped	11
Configuration in QualConnex Website	13
Required Tools for Installation	14

Contents

Assembling the QGateway Antenna and Mount	14
Determining the Magnetic Base Mount Angle and Configuration	14
Assembling the Magnetic Mount.....	17
Connecting QGateway to Magnetic Base	19
Attaching LoRa Antenna to QGateway	20
Installing the QGateway	22
QGateway Positioning	23
Power on and Confirm QGateway Cell Signal	25
Notes for troubleshooting:.....	26
Installing DGA-LT1 Monitor	26
DGA-LT1 Installation check list.....	26
DGA-LT1 Installation steps	27
Bleeding the DGA-LT1 Monitor	28
Confirm Communication	29
Removal / Decommissioning of LT1 Monitor	29
Regulatory Information	30
United States (FCC)	30
FCC RF Exposure Information.....	30
ISED (Innovation, Science and Economic Development Canada)	30
ISED RF Exposure Information.....	31
Warranty	31

Product Overview

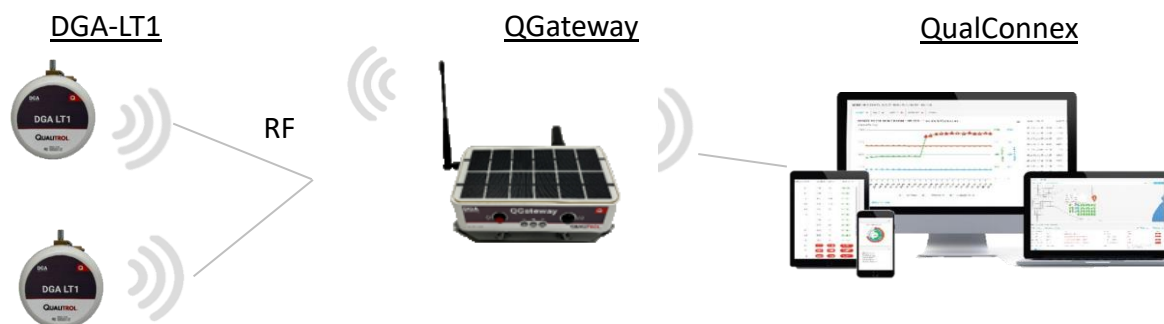

The QualConnex platform consists of 3 main parts. The DGA-LT1, QGateway, and QualConnex web portal.

DGA-LT1



The DGA-LT1 is a transformer oil sensor array reporting oil hydrogen ppm, moisture, and temperature. The DGA-LT1 sensor is directly mounted to an existing valve on the transformer and provides a continuous reading of the transformer oil. The DGA-LT1 is battery powered and wirelessly transmits encrypted raw signals via RF (Radio Frequency) to the QGateway without the need for additional power or communications wires, or cables.

The DGA-LT1 is designed to monitor hydrogen gas, with 100% specificity. Since hydrogen gas is formed under all known thermal fault conditions in oil filled transformers it is commonly referred to as the universal fault gas. In addition, Hydrogen is one of the first gases to be generated, making it an excellent early indicator of a broad range of fault types.

The monitor is designed and constructed to operate in environmental conditions typical of those found at wind farms, solar farms, non-hazardous industrial sites, power plants, switchyards, and electrical substations. The DGA-LT1 is designed to be installed and configured by the user. Due to the battery power, wireless communication, and simple installation, the DGA-LT1 provides a monitoring solution at a low cost, without the additional material and labor costs reassociated with the installation of power and communication cables to a wired monitor / sensor.

Installation & User Guide

QGateway



The QGateway receives and transmits data wirelessly from the DGA-LT1 sensors to a central monitoring platform. The QGateway is battery powered with solar battery charging. The QGateway receives and transmits encrypted raw signals via RF frequency to and from the DGA-LT1 sensors. That data is then transmitted via cellular transmission through TCP/IP to the remote monitoring system. This data is viewed via Qualitrol's QualConnex® web portal.

QualConnex® Web Application





Data from the DGA-LT1 can be viewed in the QualConnex web application. QualConnex provides the user with the ability to track oil hydrogen concentration (ppm), oil moisture concentration (%RH), and oil temperature (°C) levels over time and compare against user-defined alarm settings. The web interface displays QGateway reports including battery level and signal strength.

The QualConnex web interface allows the user to configure the monitor's alarms and settings and provides a monthly report of all monitored assets.

Symbols

The following symbols are used throughout this installation guide. Most are defined by the International Electrotechnical Commission, IEC 878 and IEC 417A or are for information only. It is important for safety reasons to understand their representation.

	Warning Statements in this guide identify conditions or practices that could result in unsafe conditions
	NOTE Statements provide additional important information or ways to prevent damage to the equipment or other property.

Product Specifications

Environmental Specifications

The DGA-LT1 and QGateway units are designed to operate within the following environmental conditions:

CHARACTERISTIC	VALUE
Altitude Maximum	8,000 ft. 2,500 m
Humidity Range	5% to 95% Noncondensing
Ambient Temperature Range	-40°F to +150°F -40°C to +65°C

DGA LT1 Specifications

The DGA-LT1 is designed to operate with the following specifications:

CHARACTERISTIC	VALUE
Measurement Interval	6, 12 or 24 Hours
Hydrogen Measurement Range	250 ppm to 10,000 ppm
Hydrogen Measurement Accuracy	±20% or ±50 ppm
Hydrogen Measurement Repeatability	±5% or ±50 ppm
Oil Temperature Range	-40°F to +220°F (-40°C to 105°C)
Temperature Accuracy	±5% or ±2°C accuracy. (~±4°F)
Moisture Measurement Range	0% to 100% RH, non-condensing
Moisture Measurement Accuracy	±5% RH
NAM RF Center Frequency	915 MHz
Oil Pressure at Installation	Needs to be >0 psig (bar) in the gas space
Oil Pressure (at drain valve)	-5 psig to 20 psig (-0.35 – 1.4 bar) with <6psig (0.4 bar) gas to oil pressure delta
Communications Certifications	IC RSS-210 Issue 8 / FCC Part 15.247
Enclosure Rating	IP67
Power Source	Battery Powered

QGateway Specifications

The QGateway is designed to operate within the following specifications:

CHARACTERISTIC	VALUE
US/Canada RF Center Frequency	915 MHz
US/Canada Cellular	LTE 3G
Operating Mode	Continuous
Power Replenishment	Solar
Power Source	Rechargeable Battery Powered

Installation & User Guide

CHARACTERISTIC	VALUE
Solar charging temp range	-4°C < t < 130°C (-20°C < t < 55°C)
Expected Availability	>90% below 55° latitude
Ambient Temperature Range	-40°F to +150°F (-40°C to 65°C)
RF Range	600m (~2000 ft) at ≥ 1.5m (~5ft) mounting height 1,500m (~5000ft) at > 10m (30ft) mounting height
Communications Certifications	IC RSS-210 Issue 8 / FCC Part 15.247
Enclosure Rating	IP65

Site Preparation

Prior to ordering and receiving your QualConnex system, the following items must be confirmed to ensure the best performance for your system. These steps will confirm that the DGA-LT1 will fit the equipment to be monitored and identify the number and placements of the QGateway(s) to cover the selected DGA-LT1 installation base.

Verify DGA-LT1 Clearance and Drain size

Verify the clearance and configuration necessary for the DGA-LT1 on the desired equipment to be monitored prior to ordering. Refer to Figure 1 for axis orientation

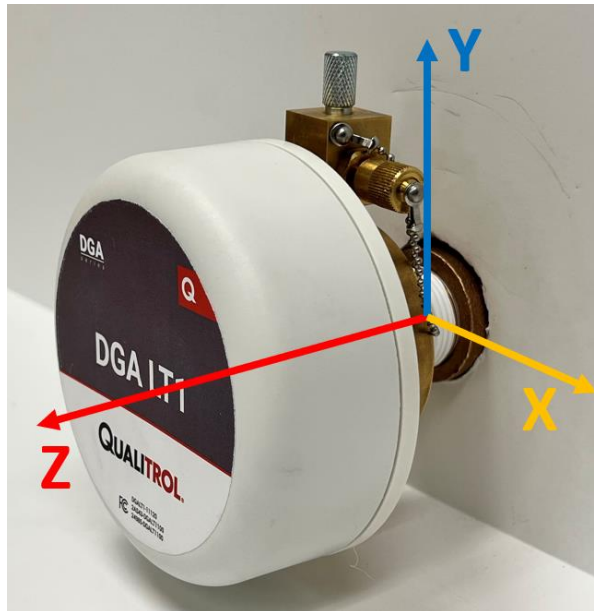

Figure 1: Directional References for DGA-LT1 Installation Clearance

Z axis is the drain valve center line. The x and y axis indicate the horizontal and vertical distance from the front face of the drain valve.

Installation & User Guide

DGA-LT1 site items to be confirmed:

- Adequate location with proper clearance for mounting the DGA-LT1 monitor has been identified
 - The system is optimized for transformers that are oil-filled.
 - The recommended installation point for the DGA-LT1 is the transformer oil drain valve
 - Qualitrol requires a 1" NPT for the transformer oil supply valve. A DGA-LT1 configured with a 2" to 1" reducing adapter is available to order
 - A 5" (12.7cm) clearance in the z direction is required for adequate spacing. If an adapter is required, a 6" (15.3 cm) z direction clearance is required.
 - A minimum of a 3.5" (8.9 cm) radial (x or y direction) clearance between the valve centerline and any surrounding structure, including the transformer foundation, is required for proper installation clearance space. There also must be adequate space to use a 12" (~30 cm long) wrench to tighten DGALT1 onto the drain valve.
- Qualitrol recommends a Dissolved Gas Analysis sample be taken at or immediately prior to installation to provide a baseline level for Hydrogen concentration
- To prevent atmospheric air from entering the transformer, the DGA-LT1 requires positive oil pressure at the drain valve for installation. The DGA-LT1 should not be installed if the equipment is under vacuum conditions.



Transformer Selection

The QualConnex system uses cellular connection to transmit data from the QGateway to the cloud. To achieve this, there must be adequate cellular signal present where the QGateway is installed to allow for reliable transmission of data.

Transformer Configuration

The transmission distance from the DGA-LT1 to the QGateway is strongly impacted by obstructions. This includes whether the DGA-LT1 is to be located in an enclosed transformer cabinet or in the open air when installed. Take note of the type of transformer and the location of the drain valve (or other approved installation point for the DGA-LT1 sensor) to properly determine the maximum distance allowed between each DGA-LT1 and QGateway. The location of the drain valve (N, S, E, W, etc.) is also critical to signal range and must be noted. See the stated Typical RF Range listed in the QGateway Specification section.

Transformer Distance Evaluation

The distance between each identified transformer for evaluation should be known. This will confirm the QGateway range to DGA-LT1 and scale the number of QGateway to sensors required. This step can be done using a web-based tool, like Google Earth, to approximate the distance or can be performed with site surveying or site maps as available. Google Earth, at time of writing, includes a measurement tool that may be used for distance measurements.

Installation & User Guide

Transformer Elevation Evaluation

Large terrain variations can also lead to reduced signal strength due to earth obstructions. The elevation of each transformer should be noted with any variations of hills or other land masses between the transformers noted. This can again be accomplished with a web-based tool like <https://en-us.topographic-map.com/>, which provides free topographical maps, or site surveying or site maps as available.

Line of Sight – Obstruction Evaluation

Large vegetation, urban development or other physical structures can lead to reduced signal strength and range. Note any obstructions that would prevent line of sight and obstructions between transformers.

Cell Coverage Evaluation

For USA (United States Americas) installs, the QGateway uses the Verizon network on band 13. For Canadian installations, the QGateway uses the Bell network on bands 5, and 13. Using a web-based tool like www.cellmapper.net can assist in determining the location of nearby tower(s) and the band(s) that those towers operate.

The direction of the tower to the transformer is also important to note for QGateway placement to optimize antenna direction and minimize obstructions.

QGateway Quantity and Location.



The QGateway must have solar access when installed to ensure recharging of the system batteries. If there are areas of heavy shading and vegetation growth, make sure to note these during site survey and avoid these areas for QGateway installation. It is more favorable to place the QGateway away from interference sources such as inverters and as high above ground level as possible.

Use the following rules of thumb to help determine quantity of QGateways needed for installation.

Calculate adjusted max range: $Adjusted\ Max\ Range = QGateway\ Range \times Obstruction\ Rating$

- IF (Closest Distance Between Two Transformers) > (Adjusted Max Range) use a 1:1 QGateway to DGA-LT1 ratio
- IF (Distance between farthest two transformers) < (Adjusted Max Range) use 1 QGateway for DGA-LT1 quantities of 1-10, 2 QGateways for DGA-LT1 quantities of 11-20, etc.
- IF (Distance between farthest two transformers) > (Adjusted Max Range):
- Approximate Number of QGateways = $ROUND\ UP\left(\frac{Distance\ between\ farthest\ two\ transformers}{Adjusted\ Max\ Range}\right)$

Example:

- Distance between the farthest 2 transformers is 600m (about 2,000 ft)
- Adjusted Max Range is 500m (about 1,700 ft)
- Approximate Number of QGateways = $ROUND\ UP(1.2) = 2$

Installation & User Guide

Accounting for Elevation Changes

It is always preferred to have the QGateway located at the highest elevation possible to ensure maximum communication range. Avoid locating the QGateway in low lying areas where hills will obstruct wireless communications to the surrounding transformers. Accounting for this may increase the number of QGateways needed depending on location availability.

Based on the above obstructions and distances and calculations, the following table can help record and scale the required number of QGateways.

Measured Value	Quantity	Notes
Number of Transformers to be monitored with DGA-LT1s		
Closest Distance between 2 transformers		
QGateway max range 1500m (5,000 ft, Open air) 600m (2,000 ft enclosure installation)		
Distance between the farthest two Transformers		
Max elevation difference between Transformers		
Obstruction rating 0.2 for heavy 0.5 for medium 0.8 for light 1 for none		

The above are rules of thumb and Qualitrol does not guarantee adequate performance of the wireless connection based on these alone. Communications performance must be confirmed at the time of installation.

Installation & User Guide

Transformer Details to Prepare for Installation

Qualitrol recommends collecting the following information during site preparation to enable configuration of the QualConnex website prior to installation. If this is not possible, the information can be collected during installation and set up in the field. The required section is the information required for the creation of a transformer in the QualConnex website (see QualConnex Website Guide for setup details). If the transformer is not set up prior or during field commissioning, DGA-LT1 sensors cannot be linked, and communication cannot be verified. This may lead to additional field visits to troubleshoot improper installation. Items in **bold** are required, the remaining items can help with tracking and diagnostics. This page can be copied to allow for information from each transformer.

Required

Company: _____ **Site:** _____

Transformer name: _____

DGA LT1 serial: _____

Transformer information:

Transformer GPS location: _____ **(in Decimal Degrees)**

Transformer Manufacturer: _____ **Model:** _____

Serial: _____

Oil Type (check one): Mineral _____ Silicone _____ Natural Ester _____ Synthetic Ester _____

Oil cooling type (check one): ONAN _____ ONAF _____ OFAF _____ OFWF _____

Tank type (check one): Air breather _____ Conservator _____ Nitrogen blanket _____ Sealed _____

Optional

Rated KVA: _____ Phase: _____ Frequency: _____ Vector: _____

HV Amps: _____ LV Amps: _____ No Load: HV _____ LV _____

Oil Volume: _____ Top oil rise: _____ Winding temp rise: _____

Minimum pressure: _____ Maximum pressure: _____

QGateway Serial number located on Transformer (if applicable): _____

Monitor Installation



Note: Do not attempt to install your DGA-LT1 On-Line Transformer Monitor until you have read and fully understand the procedures outlined in this document.



Installation of the QualConnex system consists of the following:

- Site Preparation
- All shipped items have been located
- Configuration of website
- Required tools for assembly
- Assembly and mounting the QGateway with mount
- QGateway field installation
- Installing the DGA-LT1
- Bleeding the DGA-LT1 monitor
- Commissioning



Items Shipped

Upon receipt of your transformer monitor, it is important to verify the contents of the shipping carton with the packing list. After inspection of the contents, please notify Qualitrol via our "contact us" page at www.qualitrolcorp.com/contact-us/ if there are any missing parts or any signs of damage that may have occurred in transit. If possible, please retain the original shipping container and packing materials if it becomes necessary to return the monitor.

Installation & User Guide

Part Number	Description
DGALT1-11110	 <p data-bbox="976 289 1435 436">DGA LT1, Wireless Online Dissolved Gas Analyzer Measuring Hydrogen Concentration, Moisture Concentration and Oil Temperature, 1" Connection, RF</p>
Bleed Tube	<p data-bbox="561 758 1195 789">Tubing for bleeding air from DGA LT1 after installation</p> 
GTW-RF-23310	<p data-bbox="561 1171 1395 1262">Qualitrol QGateway, Wireless Sensor Transceiver for RF to Cellular Communication, Battery Powered with recharging through Solar Power (LoRa antenna shipped detached)</p> 

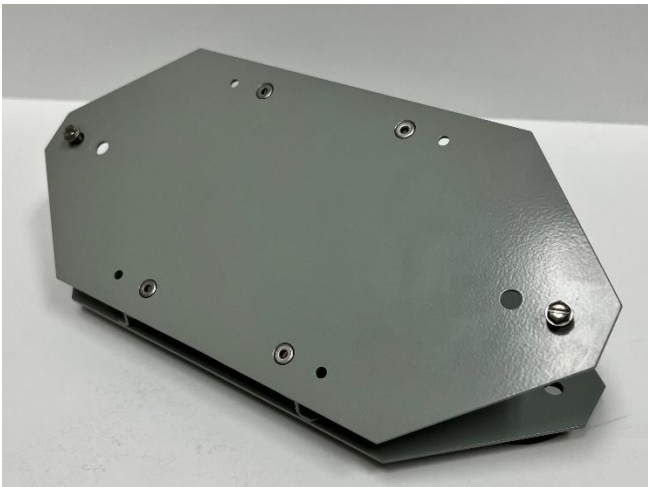
Installation & User Guide

Part Number	Description
QGateway mount	Qualitrol QGateway adjustable magnetic mount 
2" Male to 1" Female NPT Reducing Bushing ADP-251-1 (Optional)	

Configuration in QualConnex Website

With the DGA-LT1 and QGateway serial numbers confirmed with the shipping list and the transformer details collected during the site survey (see Transformer Details to Prepare for Installation list), the website should be configured prior to site installation. This will enable verification of the DGA-LT1 and QGateway while in the field and will only require verifying the associated DGA-LT1 was installed on the linked transformer (the associated transformer can be adjusted if units got switched during installation).

See Qualitrol's separate guide "QualConnex Website Guide" for instructions on how to navigate QualConnex and how to enter the required details into the website: <https://qualconnex.qualitrolcorp.com>

Installation & User Guide

Required Tools for Installation

- 1 3/8" (33mm) fixed wrench or adjustable wrench of an adequate size for leverage (12-14 inch / 30 – 35 cm)
- Extra high density Teflon tape (0.0032" or ~0.08 mm thick)
- PTFE pipe-thread sealant
- Bleed tube 1/4" (6.5 mm) ID, oil resistant (Tygon)
- Bleed container with ~1 inch (2 cm) of compatible transformer oil in the bottom.
- Absorbent towels and containers to prevent oil spills during installation.
- Brush to clean the transformer threads prior to installation (nylon is recommended due to its softer nature to prevent damage to the brass threads and compatibility with insulating oil)
- Compass (or phone app) for Solar Panel alignment
- Flat Head screwdriver or socket wrench with 1/4 " (6 mm) socket.
- Any tools and keys to unlock drain valve location
- Cell phone or computer with internet access to QualConnex website

Assembling the QGateway Antenna and Mount

The QGateway is shipped without the LoRa antenna installed and not connected to the magnetic mount. This enables field configuration to optimize performance. The following sections will detail how to determine the optimal angle for the magnetic base, assemble and connect the QGateway to the mount and install and orient the LoRa antenna.

Determining the Magnetic Base Mount Angle and Configuration







The magnetic base mounting bracket is shipped flat. The mount is designed to adjust to 3 collection angles to maximize solar energy collection based on the geographic location of the QGateway and the surface to which it is mounted – either a 30°, 45° or 60° angle (using at an angle of 60° can help with snow shed).

It is recommended to optimize your QGateway angle based on winter solar incidence angles to ensure proper charging during darker months. The optimum tilt angle is determined by adding 15° to the latitude at the installation location. For example, if the QGateway were installed in Rochester, NY, the 15° would be added to latitude of 43° giving a rounded optimum angle of 60° from horizontal.







The QGateway mount adjusts for both vertical and horizontal mounting. See Table 1 for configurations.

Installation & User Guide

Table 1 - QGateway Mount Configuration

Installation Surface	Installation Angle (from horizon)	Picture	Mounting Hardware Configuration
Horizontal	30°		
Horizontal	45°		
Horizontal	60°		

Installation & User Guide

Installation Surface	Installation Angle (from horizon)	Picture	Mounting Hardware Configuration
Vertical	30°		
Vertical	45°		
Vertical	60°		

Installation & User Guide

Assembling the Magnetic Mount

The magnetic mount is shipped as shown in Figure 2 below.

1. First open the adjustable magnetic base and attach (2) support struts using (2) flange head screws as shown in Figure 3.
2. Do not fully tighten the screws.

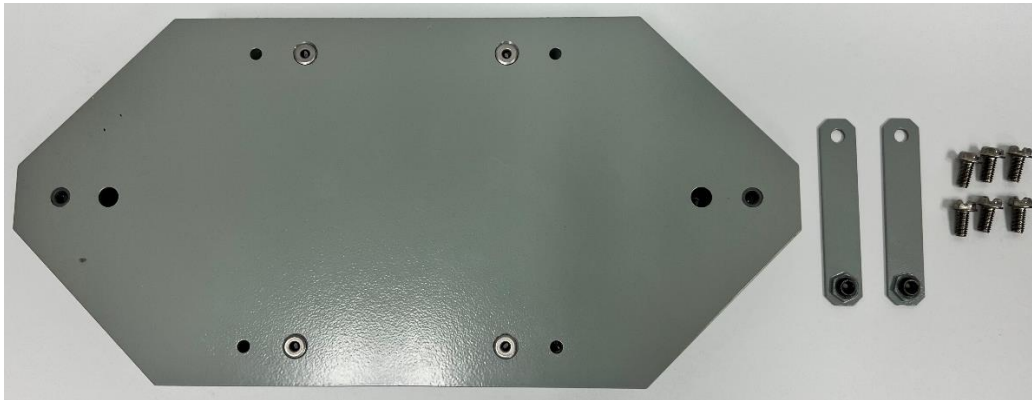

Figure 2: Magnetic mount components shipped. From left to right: (1) adjustable magnetic base, (2) support struts, (6) flange head screws

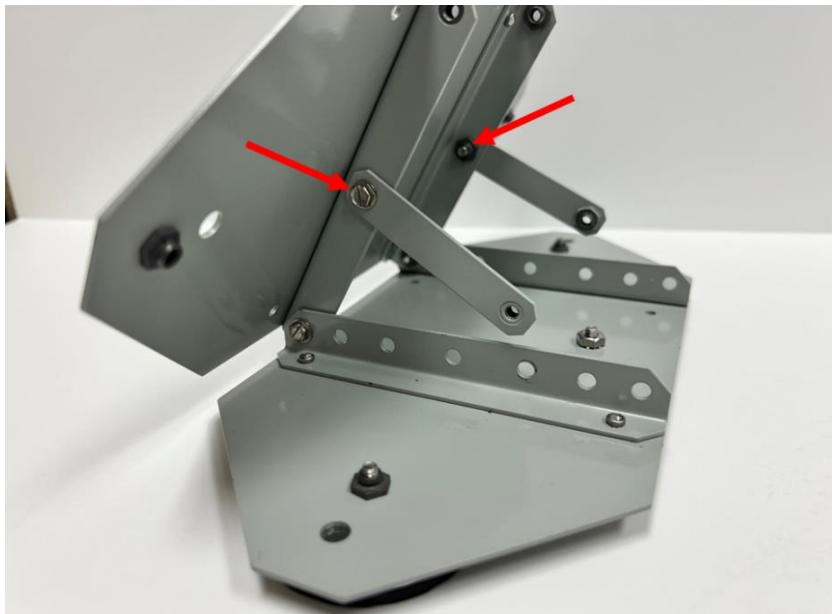

Figure 3: Attaching the support struts

3. Begin to close the adjustable base and ensure support struts sit on the *inside* of brackets on the adjustable mount as shown in Figure 4

Installation & User Guide

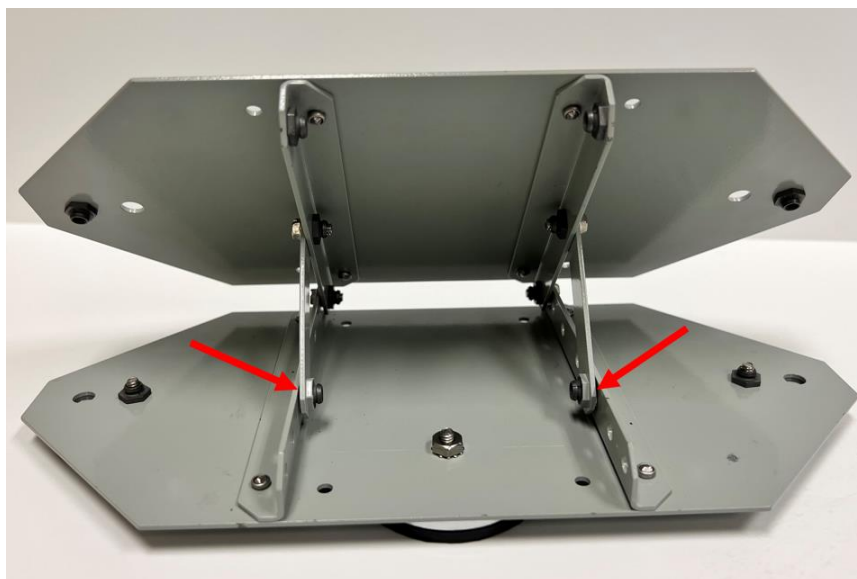

Figure 4: Support strut orientation

4. Adjust the angle of the adjustable base and align the threaded end of the support strut with the desired mounting hole per the configuration chosen as shown in Table 1.
5. Secure both support struts using (2) flange head screws as shown in Figure 5.
6. Once the supports are in the desired position, tighten all (6) flange head screws to secure the adjustable magnet mount in position.



Figure 5: Securing threaded end of the support strut

Connecting QGateway to Magnetic Base

After the base has been configured to the correct installation angle, the QGateway must be attached to the base.

1. Place the QGateway on its mounting surface on the adjustable magnet mount with the front of the QGateway facing the hinge of the adjustable magnet mount (See Figure 6 & Figure 7).



Figure 6: QGateway mounting surface



Figure 7: Front of QGateway facing the same direction as the adjustable mount hinge

2. Align the holes on the mounting tabs of the QGateway with the threaded holes on the QGateway mounting surface of the adjustable magnet mount.
3. Use the (2) remaining flange head screws to secure the QGateway to the adjustable magnet mount (See Figure 8 & Figure 9).

Installation & User Guide

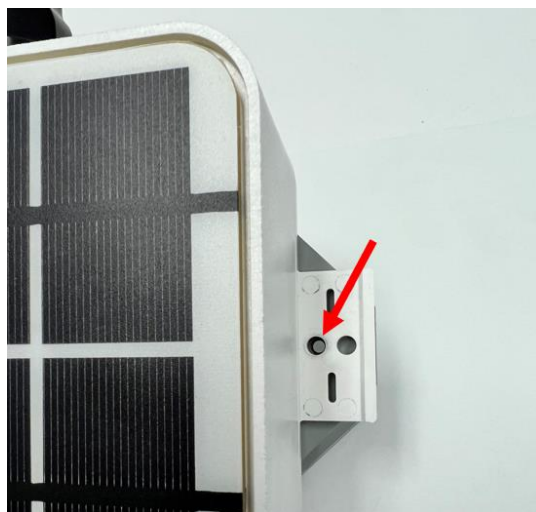

Figure 8: Align holes on QGateway tabs with threaded holes on the adjustable magnet mount

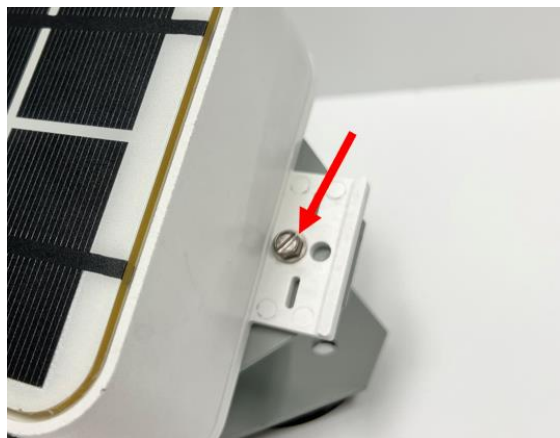

Figure 9: Secure QGateway to the adjustable magnet mount with (2) flange head screws

Attaching LoRa Antenna to QGateway

The QGateway is shipped without the LoRa antenna connected to help protect the antenna during shipment. The antenna must be attached and configured during site installation. Screw the antenna in the clockwise direction onto the SMA connector present on the outside of QGateway. While installing, ensure that the antenna is vertically oriented, perpendicular to the *ground* (not necessarily the mounting surface, depending on the mounting orientation) based on the intended mounting orientation of the QGateway (See Figure 10-12). Completely tighten the LoRa antenna using the knurled thumb screw to ensure greatest antenna stability.



Figure 10: LoRa antenna and SMA connector

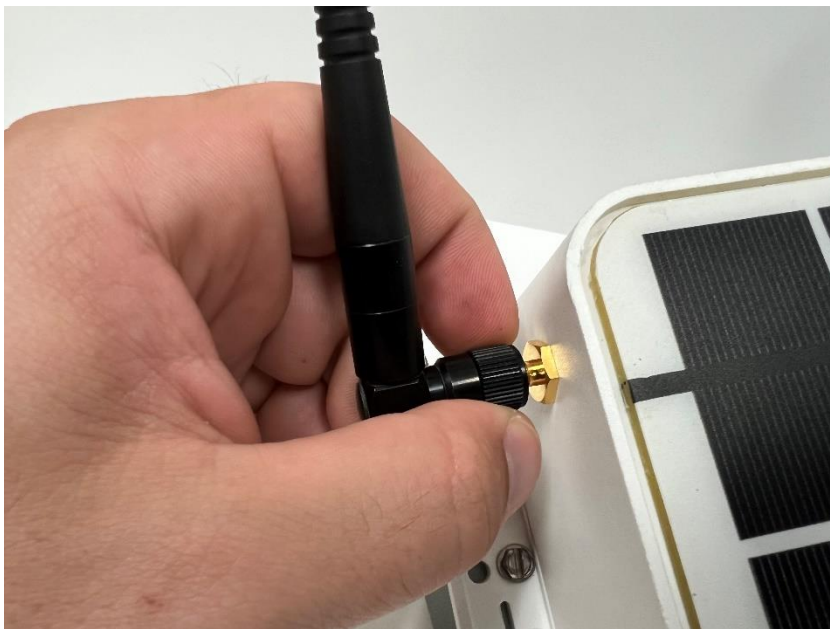

Figure 11: Screw on LoRa antenna using knurled thumb screw



Figure 12: LoRa antenna vertically oriented to the ground

Installing the QGateway

The QGateway positions should be determined during the site prep portion. A powered on and functioning QGateway is required to enable the DGA-LT1 sample confirmation during commissioning. The position of the QGateway to the DGA-LT1 will also indicate the success of the communication link or that adjustments are needed. It is Qualitrol's recommendation that the QGateway is installed first for the given DGA-LT1 sensor(s) intended to communicate with the QGateway.

The QGateway adjustable magnet mount allows for mounting in a horizontal configuration (example: top of a transformer) or vertical configuration (example: wind turbine nacelle). Other magnetic surfaces can also be used if there is sufficient surface area (10" W x 4" H) (25.5 cm W x 10.2 cm H). Note that the tabs on the QGateway could also be used for mounting on local accessible towers, buildings, or poles given that the solar panels will be properly angled for maximum solar absorption. These instructions cover mounting to a magnetic surface with the magnetic mount bracket.

Tests have provided reliable communications distances on windfarms for RF star networking to 600m (~2000 ft) when mounted on top of pad mounted transformers. If distances exceeding 600m are required, it is recommended to mount the QGateway higher. Possibilities include on top of the wind turbine nacelle, on local towers or on local poles.

Installation & User Guide

QGateway Positioning

The QGateway relies on solar panels to charge the onboard batteries. To ensure adequate power, during installation, the QGateway must be oriented to maximize solar collection.

- 1) Using a physical compass or cell phone compass app, identify south (for installations north of the equator)
- 2) Install the QGateway on the magnetic surface:
 - a. Securely grab the QGateway with (2) hands on the sides.
 - b. Gently roll the QGateway onto the magnetic surface (See Figure 13-Figure 16).

WARNING: DO NOT **attach** the QGateway to a magnetic surface by placing the magnets straight onto the surface! The rolling method described above is required. The cumulative magnetic force of the mount is ~165lbs (75 kg). Failing to properly roll on the mount as described can result in personal injury or damage to the QGateway.



WARNING: DO NOT **detach** the QGateway from a magnetic surface by pulling straight up from the mounting surface! The rolling method described above is required. The cumulative magnetic force of the mount is ~165lbs (75 kg). Failing to properly roll off the mount as described can result in personal injury or damage to the QGateway.

- 3) Ensure the QGateway unit's solar panel faces south. See Figure 13
 - a. If the unit needs to be repositioned, gently "roll" the magnets off the surface to release connection (Figure 14 - Figure 16)
- 4) Verify cellular tower direction (see Site Preparation: Cell Coverage Evaluation for cellular tower identification) and ensure that the cellular antenna is not pointing directly at the cellular tower. This scenario only occurs in a situation where the cellular tower is located directly north or south from the QGateway. This will require a reevaluation of the QGateway positioning to allow for maximized solar collection and cellular range. Consult Qualitrol if assistance is needed.

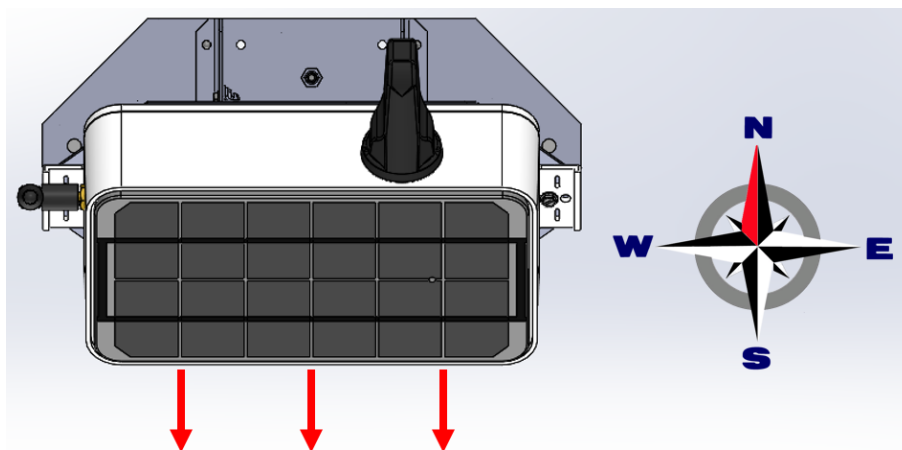

Figure 13: QGateway solar panel orientation towards due South

Installation & User Guide



Figure 14: Securely holding QGateway



Figure 15: Rolling the magnet mount onto the magnetic surface



Figure 16: Rolling the magnet mount onto the magnetic surface (cont.)

Power on and Confirm QGateway Cell Signal

After placing the QGateway in the correct install position, follow the steps to ensure the QGateway is powered on and has cellular signal.

- 1) Depress the power button to turn on the QGateway
- 2) Wait 3 minutes for the QGateway system to activate
- 3) Press and hold the status button
- 4) Confirm the green LED is on, indicating the unit has successfully powered on
- 5) Confirm the amber/yellow LED is on, indicating the unit has cellular connection.

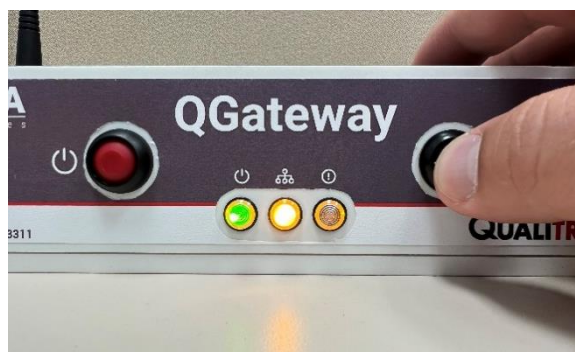

Figure 17: QGateway LEDs indicating power and cellular connection

Installation & User Guide



Notes for troubleshooting:

If the green LED does not light up, first ensure that the power button is depressed. If the button is depressed, try cycling power by pressing the power button (to turn the power off) and pressing the button again (turning the system back on). If the unit still does not show the green LED, please contact Qualitrol for help

If the amber LED does not light up, wait 3 more min to ensure the system is fully booted and has had a chance to communicate with the cellular tower. If the LED still does not illuminate, try to move the QGateway to a different location to improve cellular strength (review cellular tower location(s) identified in the site survey section).

If a red LED illuminates, this could indicate low battery. Please allow the unit 4-6 hours in sunlight to charge to an operational level and check again. If the red LED remains illuminated, please contact Qualitrol for help. The unit can be slowly charged under incandescent light.

Installing DGA-LT1 Monitor



NOTE: If the desired valve is not 1" NPT, then the appropriate hardware adapter must be installed. DGA LT1 orders can be configured with a 2" x 1" reducer bushing as an optional accessory. See Figure 18. Note that the pipe sealant is not shown in Figure 18 and is required for sealing.



Figure 18: Drain Valve showing 2" to 1" adapter



The DGA-LT1 requires positive oil pressure at the drain valve for installation. To prevent atmospheric air from entering the transformer, the DGA-LT1 should not be installed under vacuum conditions.

DGA-LT1 Installation check list

1. Ensure the transformer drain valve is closed.
2. Confirm headspace pressure gauge is zero or positive.
3. Position a container and an oil absorbent pad as needed under the valve to collect oil.

Installation & User Guide

4. Verify DGA-LT1 housing is free from external cracks
5. Note the DGA-LT1 serial number
6. Have all tools and bleed tube and container for oil collection ready

DGA-LT1 Installation steps



1. Check to make sure drain valve is closed. Failure to close the drain valve could drain a significant amount of the transformer oil and cause personal or environmental harm.
2. Remove the existing plug from the transformer drain valve and the plastic shipping cap from the LT1. Save both.
3. Clean any debris (Teflon tape, pipe thread sealant and excess oil etc.) from the valve threads with a small (nylon) brush.
4. Wrap the threads of the DGA-LT1 with extra high density Teflon tape (0.0032" or ~0.08 mm thick) and a thin layer of PTFE pipe-thread sealant.
5. Thread the DGA-LT1 sensor into the transformer drain valve, starting the threads by hand.
6. Tighten the monitor with a 1 3/8-inch or adjustable wrench until the bleed valve is vertical.
7. Clean off any extra pipe thread sealant or oil from where the monitor mounts to the valve.
8. Power on the DGA-LT1 monitor by pressing the power button.
9. Wait 1 min and press and hold the manual sample button on the back of the unit for 1 second.
10. Using the QualConnex website, verify that the unit has made successful communication with the QGateway unit, and the data has been reported to the cloud. It can take up to 15 min for data to appear depending on the QGateway distance and cellular activity.

Figure 19 below shows an installed DGA-LT1 on a 1" drain valve.



Figure 19: DGA-LT1 installed on 1" Drain Valve

Bleeding the DGA-LT1 Monitor



Warning! To prevent atmospheric air from entering the transformer, there must be positive oil pressure to install and bleed the DGA-LT1 monitor. Check the headspace pressure gauge to make sure that it is zero or positive.

1. Place an absorbent pad below the monitor to collect oil drips during bleeding.
2. Unscrew and remove bleed valve cap (blue box in Figure 20)



Figure 20: DGA-LT1 Bleed Cap

3. Install ¼" (6.5mm) inner diameter Tygon tubing over the bleed port threads (provided with the unit).

NOTE: The following is a suggested procedure that provides a visual reference indicating bleeding of the system. Other methods can be employed but vacuum (e.g., pump or syringe) should not be used to pull oil through the sensor as this may disrupt seals in the sensor)

4. Insert the other end of the Tygon tubing into an oil compatible container (all the way to the bottom) to collect transformer oil. See Figure 21 below.
 - a. Note: Some (about 1 inch or 2 cm) compatible transformer oil in the container will help in two ways.
 - i. If there is negative oil pressure, oil will be pulled up the tube, limiting amount of air introduced into the transformer (in the event of a defective headspace pressure gauge).
 - ii. Oil will siphon into the container when bleed tube is removed, making cleanup easier.

Installation & User Guide



Figure 21: DGA-LT1 Ready to Bleed Air from Unit

5. Slowly open the transformer drain valve.
6. Open the bleed valve by turning the top stainless-steel knob counterclockwise.
7. Allow all air to bleed from the system. Watch the tube to confirm oil flow. Keep the bleed fixture open until oil is flowing with no air bubbles present.
8. Close the bleed fixture valve by turning clockwise by hand until it is firmly closed.
9. Disconnect the tubing, using an absorbent towel to catch any oil drips.
10. Reinstall cap onto bleed fixture valve.
11. Confirm transformer drain valve is fully open and check for leaks.

Confirm Communication

- Login to the QualConnex website and confirm that data has been received to the associated transformer linked sensor. See “QualConnex Website Guide” for website questions and setup.
 - a. This can be done on a cell phone or tablet at site if required. Please contact Qualitrol via our "contact us" page at www.qualitrolcorp.com/contact-us/ if further assistance is required.

Removal / Decommissioning of LT1 Monitor

If the LT1 needs to be removed to perform maintenance on the transformer or to be shipped back to Qualitrol, follow these steps to ensure proper handling and prevent any damage to the unit.

1. Verify possession of required tools and accessories:
 - a. A 3/8" open end or adjustable wrench.
 - b. Oil catch tray.

Installation & User Guide

- c. Absorbent towels.
 - d. Drain valve plug and LT1 shipping cap.
 - e. Extra high density Teflon tape, 0.0032" or ~0.08 mm and sealant.
 - f. Thread cleaning brush.
2. Close transformer oil drain valve.
3. Place catch tray beneath drain valve/LT1 connection.
4. Remove bleed valve cap, place oil container under bleed valve sample port, and open the needle valve to relieve the internal pressure of the LT1.
 - a. If oil pressure is above 10 psig (1.7 bar), allow the pressure to slowly decrease. This is critical to avoid damaging the device and avoiding oil splatter that could be harmful based on oil temperature.
5. Turn off LT1
6. Slowly Remove LT1 with wrench and allow any remaining oil to drain.
7. Hand tighten shipping cap onto the LT1 threads and use absorbent towels to absorb any residual oil.
8. Place LT1 inside a padded shipping box.
9. Clean oil drain valve and plug threads with brush.



Continue if capping transformer:

10. Place at least 3 wraps of Teflon tape on plug and a thin layer of sealant.
11. Start threading plug in by hand and tighten with wrench.
12. Clean up any oil and sealant residue.

Regulatory Information

United States (FCC)

Caution: Changes or modifications not expressly approved by the party responsible for compliance could void the user's authority to operate the equipment.

This device complies with part 15 of the FCC Rules. Operation is subject to the following two conditions: (1) This device may not cause harmful interference, and (2) this device must accept any interference received, including interference that may cause undesired operation.

FCC RF Exposure Information

This equipment complies with the FCC radiation exposure limits set forth for an uncontrolled environment. This equipment should be installed and operated with a minimum distance of 20cm between the radiator and all persons. This transmitter must not be co-located or operating in conjunction with any other antenna or transmitter.

ISED (Innovation, Science and Economic Development Canada)

This radio transmitter [IC: 24985-GW200] has been approved by Innovation, Science and Economic Development Canada to operate with the antenna types listed below, with the maximum permissible gain indicated. Antenna types not included in this list that have a gain greater than the maximum gain indicated for any type listed are strictly prohibited for use with this device.

Installation & User Guide

Le présent émetteur radio [IC: 24985-GW200] a été approuvé par Innovation, Sciences et Développement économique Canada pour fonctionner avec les types d'antenne énumérés cidessous et ayant un gain admissible maximal. Les types d'antenne non inclus dans cette liste, et dont le gain est supérieur au gain maximal indiqué pour tout type figurant sur la liste, sont strictement interdits pour l'exploitation de l'émetteur.

The following table shows the antenna(s) approved for use with the QGateway.

Antenna Type	Maximum Antenna Gain (dBi)	Impedance
Right Angle Whip	2.5 dBi	50 Ohm

This device contains license-exempt transmitter(s)/receiver(s) that comply with Innovation, Science and Economic Development Canada's license-exempt RSS(s). Operation is subject to the following two conditions:

1. This device may not cause interference.
2. This device must accept any interference, including interference that may cause undesired operation of the device.

L'émetteur/récepteur exempt de licence contenu dans le présent appareil est conforme aux CNR d'Innovation, Sciences et Développement économique Canada applicables aux appareils radio exempts de licence. L'exploitation est autorisée aux deux conditions suivantes :

1. L'appareil ne doit pas produire de brouillage;
2. L'appareil doit accepter tout brouillage radioélectrique subi, même si le brouillage est susceptible d'en compromettre le fonctionnement.

ISED RF Exposure Information

This equipment complies with the ISED radiation exposure limits set forth for an uncontrolled environment. This equipment should be installed and operated with a minimum distance of 20cm between the radiator and all persons. This transmitter must not be co-located or operating in conjunction with any other antenna or transmitter.

Warranty

Qualitrol warrants its goods to be free from latent defects in materials or workmanship for the period of **one year** from the date of shipment. Additional details on terms and conditions are provided in the signed agreement. Please contact Qualitrol via our "contact us" page at www.qualitrolcorp.com/contact-us/ if there are any questions.