

**aiwa**

# AIWA Throwback

Throwback Headphones



Item: AI5002

Quick Start Guide

# WHAT'S INCLUDED



AI5002 Headphones



USB Charging Cable

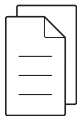

Quick Start Guide



2 extra sets of foam cushion covers

# A CLOSER LOOK

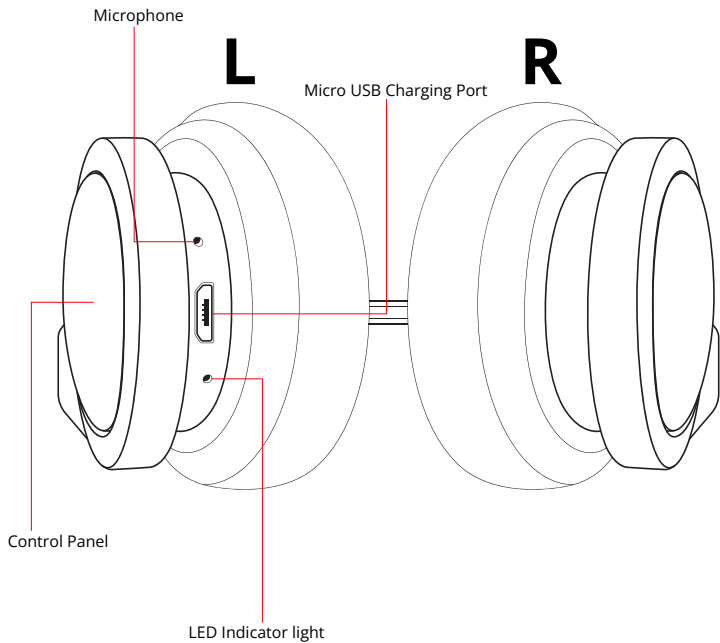

# CHARGING

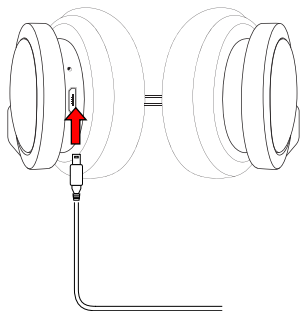

Insert one end of the included charging cable into the charging port on your headphones.

Insert the other end into the USB port of a computer or suitable USB charging adapter.

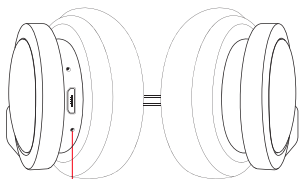
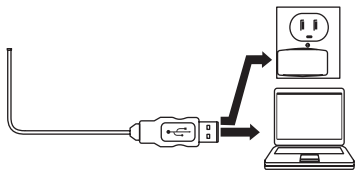

● Charging (Indicator is RED)

○ Charging Complete (Indicator Off)

# POWERING ON/OFF

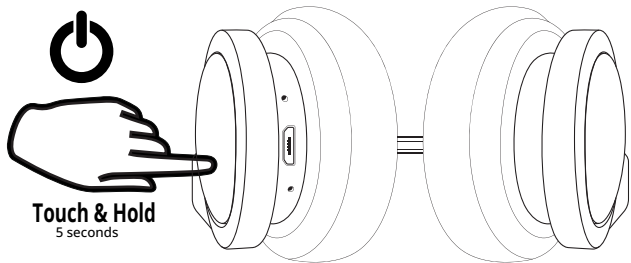

Touch and hold the Control Panel area for approximately 5 seconds to power on or power off your headphones.

# BLUETOOTH PAIRING



**Pairing Mode**  
(Blue + Red Flashing)

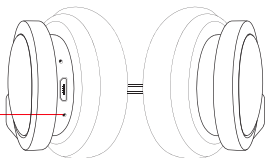

Once powered on, your headphones will go into pairing mode. The LED Indicator will alternately flash blue and red and a voice prompt will say "Power on".

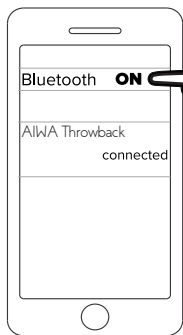

Go to the Bluetooth settings menu on your phone. Make sure that Bluetooth is turned on. Connect to the device listed as "AllWA Throwback."

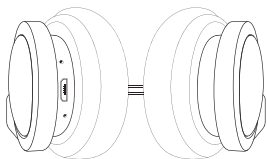

Once paired a voice prompt will state "connected".

# LISTENING TO MUSIC

  
touch

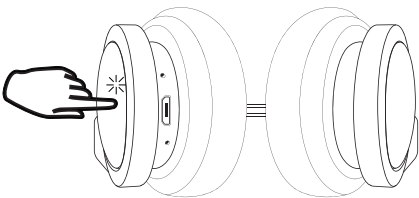

Touch the Control Panel once to play or pause music.

  
touch twice

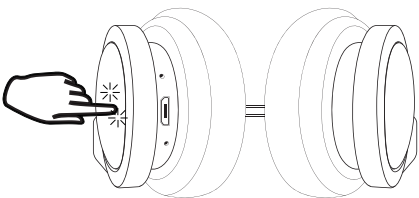

Touch the Control Panel twice to play the next song.

  
touch three times

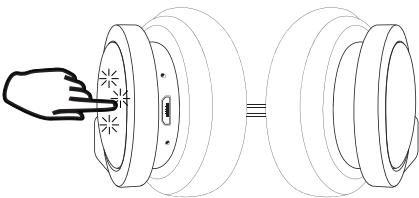

Touch the Control Panel three times to play the last song played.

# ADDITIONAL FEATURES

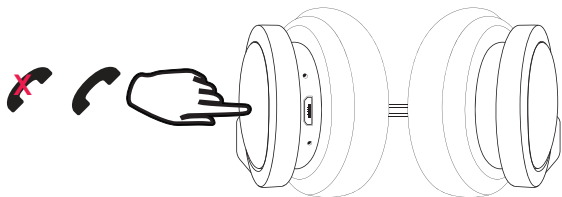

Touch the Control Panel once to pickup an incoming phone call.  
Touch and hold for approximately 2 seconds to reject an incoming phone call or end a phone call.

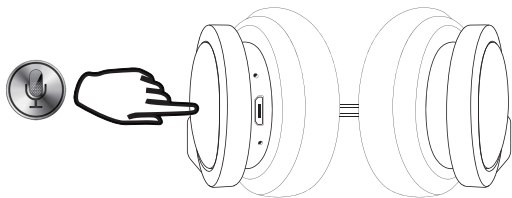

Touch and hold the Control Panel for 2 seconds to access your phone's vocal assistant.



# SAFETY PRECAUTIONS

When using your headphones, basic safety precautions should always be followed including:

1. READ ALL INSTRUCTIONS BEFORE USING YOUR HEADPHONES.
2. Do not submerge your headphones in water.
3. Only clean using a clean, soft cloth.
4. Do not allow children or the infirm to play with this product. Parental supervision is advised.
5. Do not expose this product to excessive heat or fire.
6. Do not expose this product to temperatures above 100°F. Keep out of direct sunlight.
7. Do not attempt to repair this product yourself. Contact a qualified service center if the product is in need of service.
8. Do not drop, crush, or expose this product to excessive physical force.
9. This product is not intended for commercial use.
10. When charging, keep all charging cables well ventilated. Do not keep your charging cable in contact with flammable materials such as bedding, linens or synthetic fabrics.

## Maintenance and Care

-Use a soft cloth or paper towel to clean your headphones. Never use any harsh chemicals or detergents for cleaning. Make sure your headphones are dry before charging.

-When your headphones are not in use, they should be stored in a cool, dry place.

-Never tug or yank on a cable while it is connected to your headphones. Connect and disconnect cables as carefully as possible.

-Never expose your headphones to high temperatures, extreme cold.

-Please recycle or dispose of your headphones properly based on the laws and rules of your municipality. Contact local recycling facilities and/or the manufacturer of your headphones for further information.



Warning

To prevent possible hearing damage, do not listen at high volume levels for long periods. For your own safety, please be aware of your surroundings when using these headphones.

# FCC STATEMENT

Changes or modifications not expressly approved by the party responsible for compliance could void the user's authority to operate the equipment.

This device complies with Part 15 of the FCC Rules. Operation is subject to the following two conditions: (1) this device may not cause harmful interference, and (2) this device must accept any interference received, including interference that may cause undesired operation.

This equipment has been tested and found to comply with the limits for a Class B digital device, pursuant to Part 15 of the FCC Rules. These limits are designed to provide reasonable protection against harmful interference in a residential installation. This equipment generates, uses and can radiate radio frequency energy and, if not installed and used in accordance with the instructions, may cause harmful interference to radio communications. However, there is no guarantee that interference will not occur in a particular installation. If this equipment does cause harmful interference to radio or television reception, which can be determined by turning the equipment off and on, the user is encouraged to try to correct the interference by one or more of the following measures:

- Reorient or relocate the receiving antenna.
- Increase the separation between the equipment and receiver.
- Connect the equipment into an outlet on a circuit different from that to which the receiver is connected.
- Consult the dealer or an experienced radio/TV technician for help.

FCC Radiation Exposure Statement:

The device has been evaluated to meet general RF exposure requirement.

The device can be used in the portable exposure condition without restriction.

# SPECIFICATIONS

**BLUETOOTH VERSION:** 5.4

**WORKING DISTANCE:** UP TO 10 METERS

**CHARGE TIME:** APPROXIMATELY 2 HOURS

**PLAY TIME:** UP TO 40 HOURS\*

**BATTERY** 3.7V 300mAh Lithium Ion Battery

**CHARGING VOLTAGE:** 5V DC

**CHARGING INTERFACE:** Micro USB

\*Applicable at 50% of maximum volume. Results will be lower when volume is higher.

# WARRANTY

This warranty covers the original consumer purchaser only and is not transferable.

This warranty covers products that fail to function properly UNDER NORMAL USAGE, due to defects in material or workmanship. Your product will be repaired or replaced at no charge for parts or labor for a period of one year.

## What Is Not Covered By Warranty

Damages or malfunctions not resulting from defects in material or workmanship and damages or malfunctions from other than normal use, including, but not limited to, repair by unauthorized parties, tampering, modification or accident.

## To Obtain Warranty Service and Troubleshooting Information:

Call 1-800-592-9541 or visit our website at [www.aiwa.co](http://www.aiwa.co).

To receive Warranty service along with the name and address of an authorized product service center, the original consumer purchaser must contact us for problem determination and service procedures. Proof of purchase in the form of a bill of sale or receipted invoice, evidencing that the product is within the applicable Warranty period(s), MUST be presented in order to obtain the requested service. It is your responsibility to properly package and send any defective products along with a dated copy of proof of purchase, a written explanation of the problem, and a valid return address of the authorized service center at your expense. Do not include any other items or accessories with the defective product. Any products received by the authorized service center that are not covered by warranty will be returned unrepaid.



**AIWA**

Edison, NJ 08817

© 2024 Aiwa Acquisitions LLC. All rights reserved. AIWA and associated marks are owned by Aiwa Acquisitions and used under license. Keep all relevant information for future reference.

The Bluetooth® word mark and logos are registered trademarks owned by the Bluetooth SIG, Inc. and any use of such marks by Sakar International is under license.