

# LightGrid Gateway

## Outdoor Wireless Control System



### BEFORE YOU BEGIN

Read these instructions completely and carefully.

#### FCC Statements:

**Note:** This equipment has been tested and found to comply with the limits for a Class B digital device, pursuant to part 15 of the FCC Rules. These limits are designed to provide reasonable protection against harmful interference in a residential installation. This equipment generates, uses and can radiate radio frequency energy and, if not installed and used in accordance with the instructions, may cause harmful interference to radio communications. However, there is no guarantee that interference will not occur in a particular installation. If this equipment does cause harmful interference to radio or television reception, which can be determined by turning the equipment off and on, the user is encouraged to try to correct the interference by one or more of the following measures:

- Reorient or relocate the receiving antenna.
- Increase the separation between the equipment and receiver.
- Connect the equipment into an outlet on a circuit different from that to which the receiver is connected.
- Consult the dealer or an experienced radio/TV technician for help.

To satisfy FCC/ISED RF exposure requirements a separation distance of 20 cm or more must be maintained between the antenna of this device and persons during operation. Operation at closer than 20 cm is not permitted.

#### CAN ICES-5 (B)/NMB-3(B)

This device complies with Industry Canada license-exempt RSS standards. Operation is subject to the following two conditions:

- This device may not cause harmful interference, and
- This device must accept any interference received, including interference that may cause undesired operation.

Cet appareil est conforme aux normes RSS exemptées de licence de Industrie Canada. Son fonctionnement est soumis aux deux conditions suivantes:

- Cet appareil ne doit pas provoquer d'interférences et
- Cet appareil doit accepter toute interférence, y compris celles pouvant causer un mauvais fonctionnement de l'appareil.

Pour être conforme aux limites d'exposition aux ondes RF des normes FCC/ISED, une distance de séparation d'au moins 20 cm doit être maintenue entre l'antenne de cet appareil et toute personne pendant son opération. Mettre en opération cet appareil à une distance plus rapprochée que 20 cm n'est pas permis.

#### ⚠ WARNING

##### RISK OF ELECTRIC SHOCK

Disconnect power before servicing or installing product.

##### RISK OF INJURY OR DAMAGE

Unit will fall if not installed properly. Follow installation instructions. Install in accordance with National Electric Code and local codes.

#### ⚠ CAUTION

##### RISK OF INJURY

Wear safety glasses and gloves during installation and servicing.

##### RISK OF CHANGES OR MODIFICATIONS

The user is cautioned that changes or modifications not expressly approved by the party responsible for compliance could void the user's authority to operate the equipment.

### Product Certifications

FCC ID: 2AS3F-90002

ISED ID: 25008-90002

HVIN: WOLC Gateway

## Before Installation

- **Carefully unpack unit.** Inspect for defects before installing.
- **Check Electrical parameters.** Ensure that the voltage at the pole is 120-277V.
- **Verify that power feed is on 24/7 constant power.** The LightGrid mesh will not operate properly when operating on switched power from a master timer or photocell.
- **Plan Route to install Gateways at the locations recommended by Current Team.** Gateways must be located at strategic spots in the deployment to carefully balance the way the mesh forms. Based on the pole locations of all the desired Controllers that will be installed, the Current team will perform an RF simulation and recommend where the Gateways should be installed. Failure to follow the recommended installation locations may cause areas of the deployment to have no mesh network communications, or to overload the mesh causing poor connectivity and performance.
- **If the Gateway will be using a wired connection (fiber / Ethernet),** consultation and network architecture design must be completed and approved by the Current IT Team prior to installation of any Gateways. (Note: Current strongly recommends using Current provided cellular backhaul instead of wired connections).

## Where to Install

Best performance will be achieved when the Gateway antenna is as high above ground level as possible. Do not install the unit inside of any other enclosure. Gateways can be mounted on a light pole up to 16" in diameter, or on a pole-like structure on a rooftop. For more details about Rooftop Mounting, see Appendix A. The Gateway is to be mounted with the pole mounting brackets horizontal, and the latch facing upwards. The Antenna must be mounted vertically.

## Gateway Specifications

- 120-277V AC Input
- Weight: 7 lbs. (3.2 kg)
- Dimensions: 7.6" x16" x11" [193 x 406 x 280mm]
- Operating Temp Range: -40 to +50°C

## Mounting the Gateway

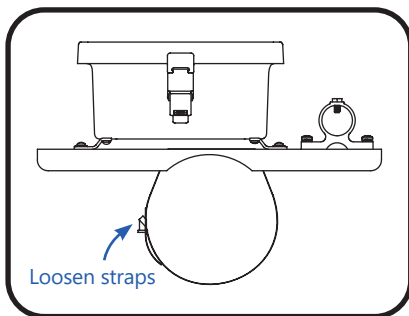

- ① **Unpack:**  
Loosen the steel straps, and adjust to the pole-mounting configuration shown below.

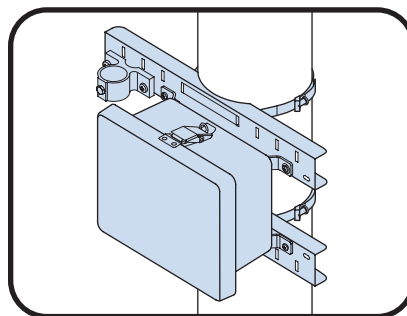

- ② **Mount to Pole:**  
Using the provided steel straps, mount the Gateway assembly securely to the pole structure. Tighten the straps to ensure the unit will not slide or vibrate loose.

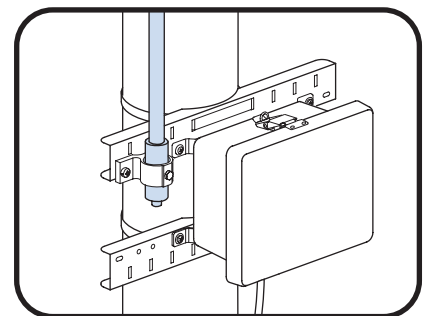

- ③ **Mount the RF Antenna:**  
The RF Antenna is a separate part in the box. Insert it to the Antenna Mounting Collar attached to the Gateway pole mounting assembly, and tighten the mounting bolt to 45 lbs-in torque.

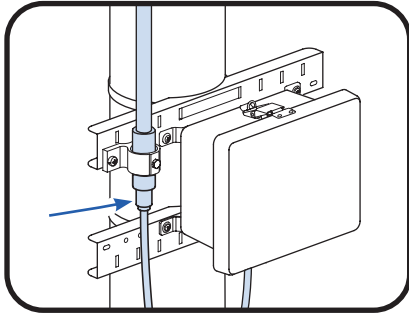

**4 Connect the Coax RF Cable to the RF Antenna:**

The RF Cable is pre-installed on the gateway assembly. Attach to the screw terminal on the bottom of the RF Antenna, and tighten securely.

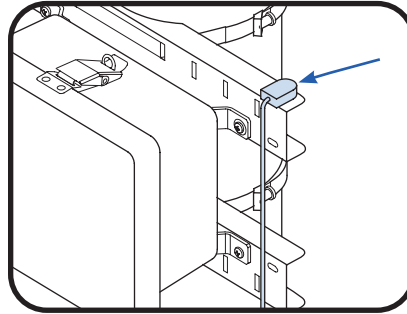

**5 Position the magnetic GPS Antenna on the TOP of the metal pole mounting bracket.**

It must be on the top bracket, facing upwards, in order to have a clear view of the open sky.

This radio transmitter (IC: 25008-90002) has been approved by Innovation, Science and Economic Development Canada to operate with the antenna types listed below, with the maximum permissible gain indicated. Antenna types not included in this list that have a gain greater than the maximum gain indicated for any type listed are strictly prohibited for use with this device.

Antenna Type	Maximum Permissible Antenna Gain (dBi)	Required Impedance
Laird FG9023	5	50Ω

**6 Connect AC Power Cable:**

AC Power cable is not included. Power cable shall be Hard or Junior Hard Service Flexible Cord type, suitable for use with the Liquid Tight Cable Gland supplied with the box, and should have circular cross section between Ø0.170" – Ø0.450"/[Ø4.3- Ø11.4mm].

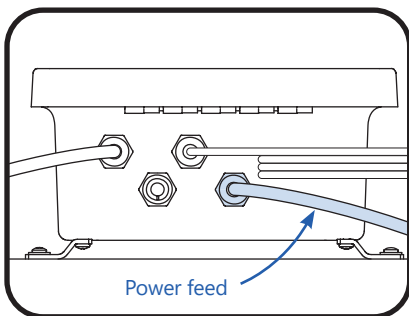

**6a** Insert the power feed cable through the cable gland in the bottom of the Gateway enclosure.

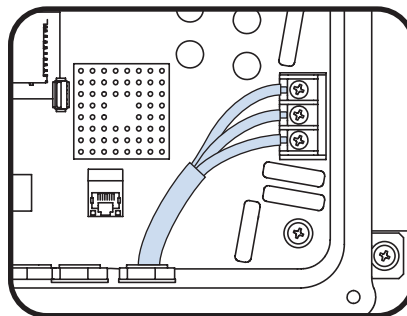

**6b** Strip each wire no more than 0.25". Route the power cable as tightly as possible (avoid larger than necessary loops/slack) to the terminal block inside the enclosure. Avoid touching any other component on the Gateway circuit board.

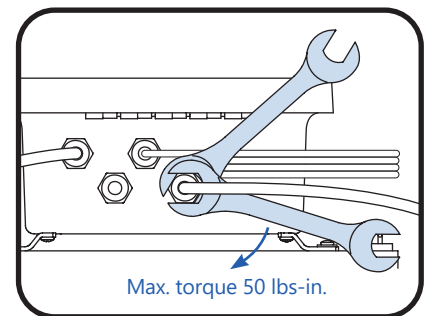

**6c** Use a wrench to hold the gland body in place, preventing it from rotating, and tighten the sealing nut of the Gland to ensure a watertight seal to the cable. Max torque on sealing nut 50 lbs-in.

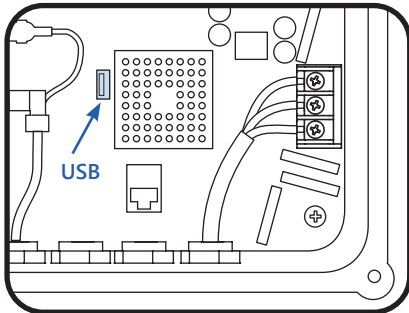

**7 USB Cable:**  
When gateway is used with an included cellular modem mounted in the enclosure, ensure the USB cable to the modem is securely plugged in to the USB port on the gateway circuit board. If the Gateway is being used with a wired (Ethernet) connection, see Appendix B for more information.

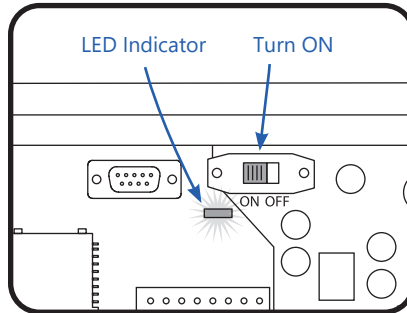

**8 Provide Power and turn ON the ON/OFF Switch.**  
Ensure the gateway ON/OFF switch starts in OFF position. Check that input power voltage is in the range 120-277VAC and is 24/7 constant power. Turn on the input power source, then switch the gateway ON/OFF switch to the ON position. Check the indicator light underneath the Gateway ON/OFF switch. A solid green light means the gateway is powered.

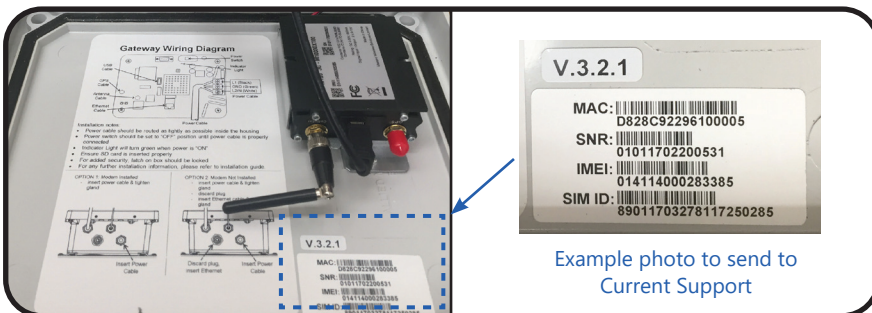

**9 Record the Cellular Modem ID numbers.**  
The ID numbers are found on the sticker on the inside lid of the enclosure. Take a picture or write down all numbers on the sticker, and provide these to the Current Support Team for commissioning by emailing them to [lightgridsupport@gecurrent.com](mailto:lightgridsupport@gecurrent.com).

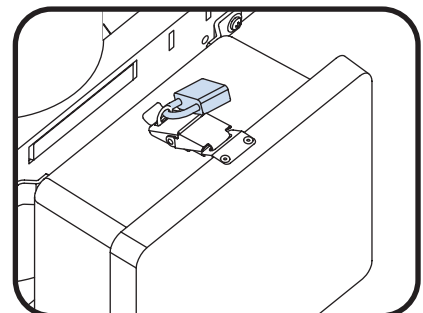

**10 Close the Lid.**  
To ensure a waterproof installation, check that no wires or other objects will be caught under the rubber seal on the housing lid. Then close the lid and lock using the latch on top. The latch can be padlocked for added security (not included).

## Appendix A: Rooftop Mounting

Example Roof Mount Structures



- ⑪ Photos show examples of rooftop installation structures for mounting the Gateway. It is the installer’s responsibility to select a location where the gateway antenna will be above other obstructions on the roof and will have direct line-of-sight to multiple fixtures that will have LightGrid Controllers on them.

## Appendix B: Ethernet Connection

This instruction will not apply to the majority of LightGrid installations. The Gateway cannot be simply plugged into an Ethernet connection, it will not function properly—use of an Ethernet wired backhaul requires approval of the network architecture, design, support plan, and connectivity implementation by the Current IT Team. Current strongly recommends the use of Current-provided cellular modem and data service as the preferred backhaul. If use of Ethernet has been approved, the installation steps are the same however the Ethernet cable must be fed into the enclosure and connected to the Ethernet jack on the printed circuit board.

- ① Ethernet cable should be of circular cross-section with overall diameter in the range  $\varnothing 0.210'' - \varnothing 0.334'' / \varnothing 5.3 - \varnothing 8.5\text{mm}$ .

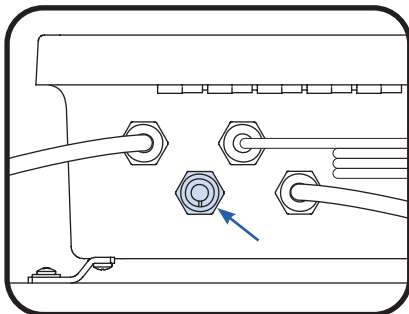

- ② Remove and discard the plug that is in the gland shown.

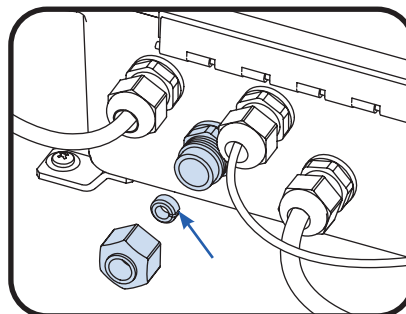

- ③ Remove the split rubber grommet from the threaded sealing nut.

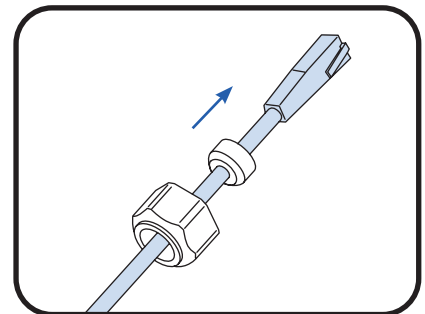

- ④ Thread the Ethernet cable through the sealing nut, and snap on the rubber grommet in front.

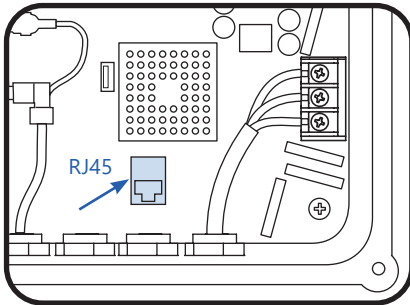

- ⑤ Push the cable through the sealing gland, and plug it in to the RJ45 Ethernet jack on the circuit board.

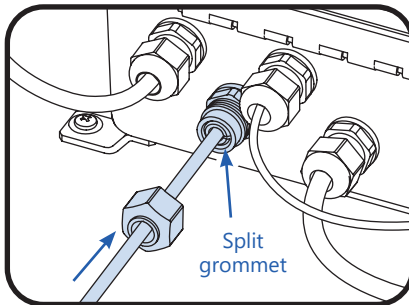

- ⑥ Slide the split grommet into the gland, then tighten the sealing nut to ensure a watertight seal around the cable. When tightening the nut, use a wrench to prevent the gland body from rotating. Max torque on the sealing nut: 50 lbs-in.

- ⑦ After following all of the other steps in the primary installation instructions, the customer IT lead will need to contact the Current IT team to check and troubleshoot any connectivity issues by emailing [lightgridsupport@gecurrent.com](mailto:lightgridsupport@gecurrent.com).

## Questions

- Email: [lightgridsupport@gecurrent.com](mailto:lightgridsupport@gecurrent.com)
- Leave a Voicemail: 1-877-843-5590