

## FCC- TEST REPORT

Report Number : **68.940.18.0053.01** Date of Issue: 18 February 2019

Model : **S-1801, S-1801A**

Product Type : Camera sensor wall light

Applicant : Ningbo Fiercer Leopard Electrical Appliance Co., Ltd.

Address : No. 1&2, Wanghai Road (Wanghai Industrial Area) Xidian Town,  
315611 Ninghai, Ningbo Zhejiang,  
PEOPLE'S REPUBLIC OF CHINA

Production Facility : Ningbo Fiercer Leopard Electrical Appliance Co., Ltd.

Address : No. 1&2, Wanghai Road (Wanghai Industrial Area) Xidian Town,  
315611 Ninghai, Ningbo Zhejiang,  
PEOPLE'S REPUBLIC OF CHINA

Test Result :  **Positive**       **Negative**

Total pages including Appendices : 57

*TÜV SÜD Certification and Testing (China) Co., Ltd. Shenzhen Branch is a subcontractor to TÜV SÜD Product Service GmbH according to the principles outlined in ISO 17025.*

*TÜV SÜD Certification and Testing (China) Co., Ltd. Shenzhen Branch reports apply only to the specific samples tested under stated test conditions. Construction of the actual test samples has been documented. It is the manufacturer's responsibility to assure that additional production units of this model are manufactured with identical electrical and mechanical components. The manufacturer/importer is responsible to the Competent Authorities in Europe for any modifications made to the production units which result in non-compliance to the relevant regulations. TÜV SÜD Certification and Testing (China) Co., Ltd. Shenzhen Branch shall have no liability for any deductions, inferences or generalizations drawn by the client or others from TÜV SÜD Certification and Testing (China) Co., Ltd. Shenzhen Branch issued reports.*

*This report is the confidential property of the client. As a mutual protection to our clients, the public and ourselves, extracts from the test report shall not be reproduced except in full without our written approval.*



# 1 Table of Contents

- 1 Table of Contents .....2
- 2 Details about the Test Laboratory.....3
- 3 Description of the Equipment under Test .....4
- 4 Summary of Test Standards.....5
- 5 Summary of Test Results.....6
- 6 General Remarks .....7
- 7 Test Setups .....8
- 8 Systems test configuration.....9
- 9 Technical Requirement .....10
  - 9.1 Conducted Emission .....10
  - 9.2 Conducted Average output power .....12
  - 9.3 6dB and 99% bandwidth .....14
  - 9.4 Power spectral density.....22
  - 9.5 Spurious RF conducted emissions .....29
  - 9.6 Band edge .....42
  - 9.7 Spurious radiated emissions for transmitter .....47
- 10 Test Equipment List.....56
- 11 System Measurement Uncertainty .....57

## 2 Details about the Test Laboratory

### Details about the Test Laboratory

#### Test Site 1

Company name: TÜV SÜD Certification and Testing (China) Co., Ltd. Shenzhen Branch  
Building 12&13, Zhiheng Wisdomland Business Park,  
Nantou Checkpoint Road 2, Nanshan District,  
Shenzhen City, 518052,  
P. R. China

FCC Registration Number: 514049

Telephone: 86 755 8828 6998  
Fax: 86 755 8828 5299

### 3 Description of the Equipment under Test

#### Description of the Equipment Under Test

Product:	Camera sensor wall light
Model no.:	S-1801, S-1801A
FCC ID:	2ARY8-S-18
Options and accessories:	NIL
Rated Input:	100-240VAC, 50/60Hz
Rated Power:	13W
RF Transmission Frequency:	2412-2462MHz
No. of Operated Channel:	11
Modulation:	CCK, DQPSK, DBPSK for 802.11b QPSK, BPSK for 802.11g/n
Duty Cycle:	100%
Antenna Type:	Integral Antenna
Antenna Gain:	5dBi
Description of the EUT:	II



## 4 Summary of Test Standards

Test Standards	
FCC Part 15 Subpart C 10-1-2018 Edition	PART 15 - RADIO FREQUENCY DEVICES Subpart C - Intentional Radiators

All the test methods were according to KDB558074 D01 v05 DTS Measurement Guidance and ANSI C63.10 (2013).

## 5 Summary of Test Results

Technical Requirements			
FCC Part 15 Subpart C			
Test Condition		Test Result	Test Site
§15.207	Conducted emission AC power port	Pass	Site 1
§15.247(b)(1)	Conducted peak output power	Pass	Site 1
§15.247(e)	Power spectral density*	Pass	Site 1
§15.247(a)(2)	6dB bandwidth	Pass	Site 1
§15.247(a)(1)	20dB bandwidth and 99% Occupied Bandwidth	Pass	Site 1
§15.247(a)(1)	Carrier frequency separation	N/A	--
§15.247(a)(1)(iii)	Number of hopping frequencies	N/A	--
§15.247(a)(1)(iii)	Dwell Time	N/A	--
§15.247(d)	Spurious RF conducted emissions	Pass	Site 1
§15.247(d)	Band edge	Pass	Site 1
§15.247(d) & §15.209 & §15.203	Spurious radiated emissions for transmitter	Pass	Site 1
§15.203	Antenna requirement	See note 1	

Remark 1: N/A – Not Applicable.

Note 1: The EUT uses a permanently integral antenna, which gain is 2dBi. According to §15.203, it is considered sufficiently to comply with the provisions of this section.

## 6 General Remarks

### Remarks

This submittal(s) (test report) is intended for FCC ID: 2ARY8-S-18, complies with Section 15.207, 15.209, 15.205, 15.247 of the FCC Part 15, Subpart C rules.

The models S-1801 and S-1801A are same except the appearance of the lamp head and the LED module.

So all the EMC test requirements were applied on S-1801A, S-1801 is deemed to fulfill relevant EMC requirement without further testing.

The EUT has multiple work modes, the worst test results are listed in the report.

### SUMMARY:

All tests according to the regulations cited on page 5 were

- Performed

- **Not** Performed

The Equipment under Test

- **Fulfills** the general approval requirements.

- **Does not** fulfill the general approval requirements.

Sample Received Date: November 11, 2018

Testing Start Date: November 11, 2018

Testing End Date: January 18, 2019

- TÜV SÜD Certification and Testing (China) Co., Ltd. Shenzhen Branch -

Reviewed by:

Prepared by:

Tested by:

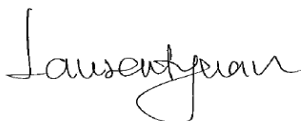
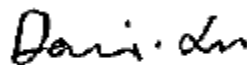
\_\_\_\_\_  
Laurent Yuan  
EMC Project Manager

\_\_\_\_\_  
Dawi Xu  
EMC Project Engineer

\_\_\_\_\_  
Tree Zhan  
EMC Test Engineer

## 7 Test Setups

### 7.1 Radiated test setups

Below 1GHz

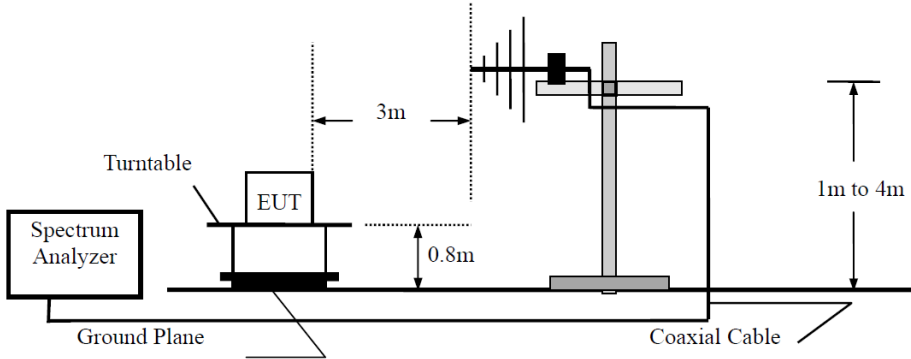

Above 1GHz

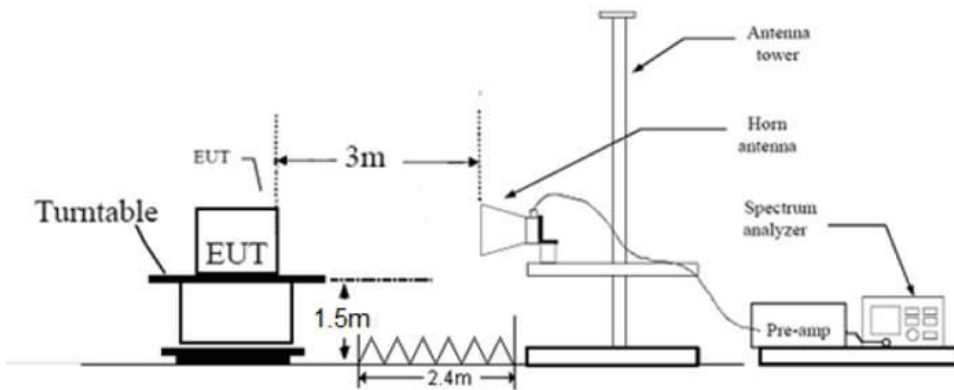

### 7.2 Conducted RF test setups

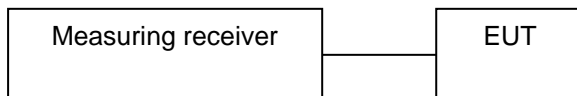

### 7.3 AC Power Line Conducted Emission test setups

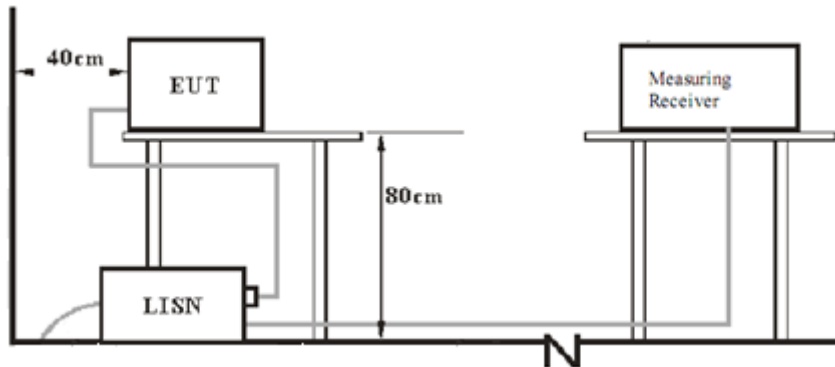



## 8 Systems test configuration

Auxiliary Equipment Used during Test:

DESCRIPTION	MANUFACTURER	MODEL NO.(SHIELD)	S/N(LENGTH)
---	---	---	---

Test software: RF test tool

The system was configured to channel 1, 6 and 11 for the test.

## 9 Technical Requirement

### 9.1 Conducted Emission

M/N: S-1801A  
 Op Cond.: ON & Camera  
 Test Spec.: Power Line, Live  
 Comment: AC 120V/60Hz

Temperature (°C): 22.5 Relative Humidity (%): 46.7 Atmospheric Pressure(mbar) : 1012

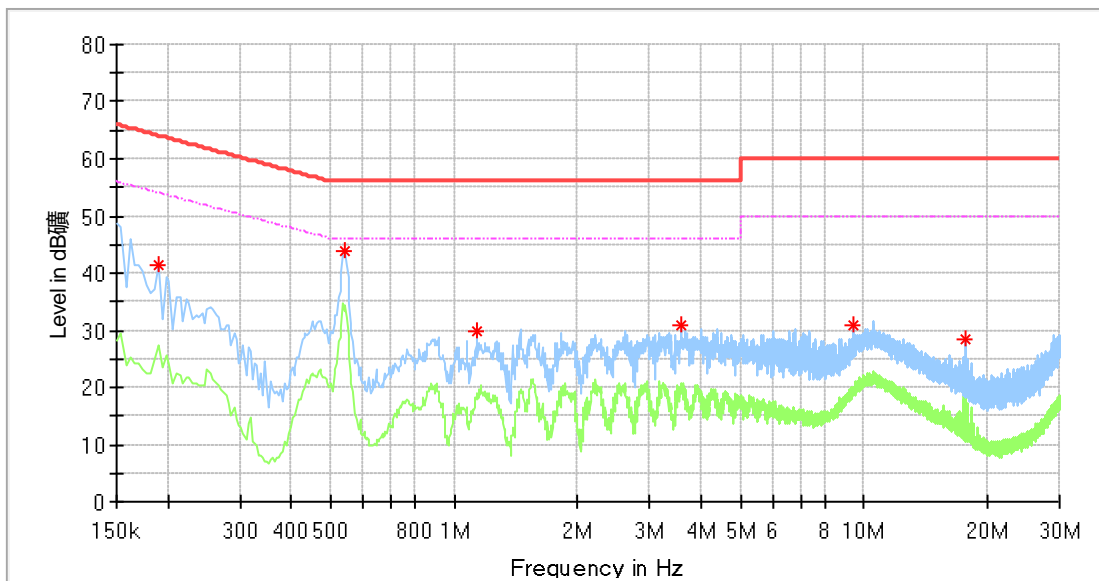

Frequency (MHz)	MaxPeak (dBµV)	Average (dBµV)	Limit (dBµV)	Margin (dB)	Line	Corr. (dB)
0.190000	41.49	---	64.04	22.55	L1	10.2
0.542000	43.72	---	56.00	12.28	L1	10.3
1.134000	29.95	---	56.00	26.05	L1	10.3
3.590000	30.87	---	56.00	25.13	L1	10.4
9.462000	30.86	---	60.00	29.14	L1	10.6
17.694000	28.52	---	60.00	31.48	L1	10.9

**Conducted Emission Test 150kHz – 30MHz**

M/N: S-1801A  
 Op Cond.: ON & Camera  
 Test Spec.: Power Line, Neutral  
 Comment: AC 120V/60Hz

Temperature (°C): 22.5 Relative Humidity (%): 46.7 Atmospheric Pressure(mbar) : 1012

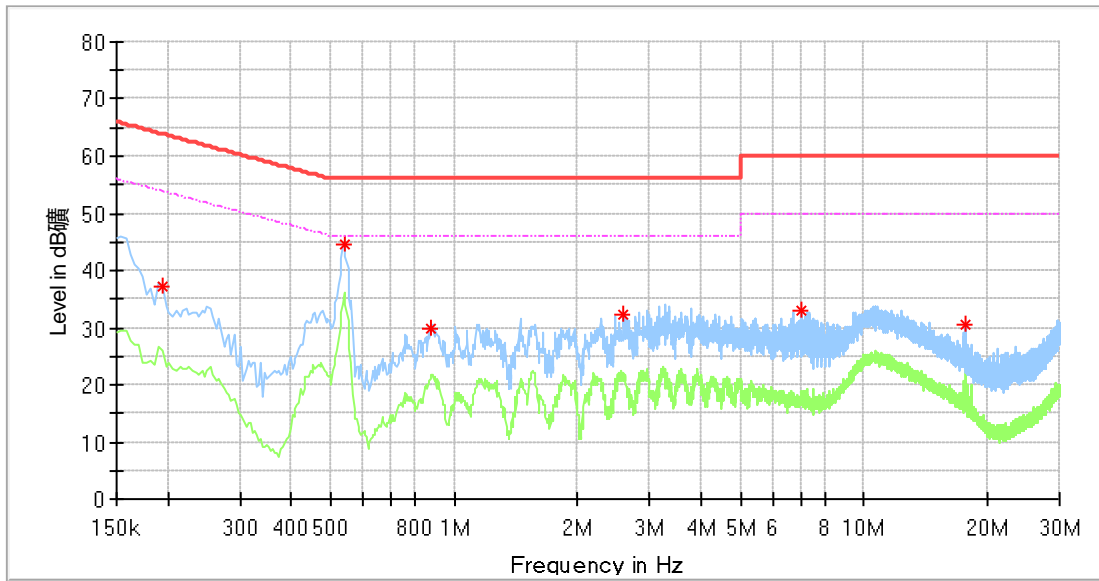

Frequency (MHz)	MaxPeak (dBµV)	Average (dBµV)	Limit (dBµV)	Margin (dB)	Line	Corr. (dB)
0.194000	37.23	---	63.86	26.63	N	10.2
0.538000	44.64	---	56.00	11.36	N	10.3
0.882000	29.73	---	56.00	26.27	N	10.3
2.582000	32.20	---	56.00	23.80	N	10.3
6.994000	33.05	---	60.00	26.95	N	10.6
17.694000	30.57	---	60.00	29.43	N	11.1

## 9.2

### 9.2 Conducted Average output power

#### Test Method

1. Connect the power meter to the EUT
  - a) The EUT is configured to transmit continuously, or to transmit with a constant duty factor.
  - b) At all times the EUT is transmitting at its maximum power control level.
  - c) The integration period of the power meter exceeds the repetition period of the transmitted signal by at least a factor of five.
2. Measure the average power of the transmitter. This measurement is an average over both the on and off periods of the transmitter.
3. Adjust the measurement in dBm by adding  $10\log(1/x)$ , where x is the duty cycle to the measurement result.

#### Limits

According to §15.247 (b) (1), conducted av output power limit as below:

Frequency Range MHz	Limit W	Limit dBm
2400-2483.5	≤1	≤30

Test result as below table

802.11b

Frequency MHz	Conducted AV Output Power dBm	Result
Top channel 2412MHz	14.9	Pass
Middle channel 2437MHz	14.8	Pass
Bottom channel 2462MHz	14.5	Pass

802.11g

Frequency MHz	Conducted AV Output Power dBm	Result
Top channel 2412MHz	10.8	Pass
Middle channel 2437MHz	10.3	Pass
Bottom channel 2462MHz	10.1	Pass

## 802.11nHT20

Frequency MHz	Conducted AV Output Power dBm	Result
Top channel 2412MHz	10.7	Pass
Middle channel 2437MHz	10.4	Pass
Bottom channel 2462MHz	10.0	Pass

## 802.11nHT40

Frequency MHz	Conducted AV Output Power dBm	Result
Top channel 2422MHz	11.0	Pass
Middle channel 2437MHz	11.3	Pass
Bottom channel 2452MHz	11.2	Pass

### 9.3 6dB and 99% bandwidth

#### Test Method

1. Use the following spectrum analyzer settings:  
RBW=100K, VBW $\geq$ 3RBW, Sweep = auto, Detector function = peak, Trace = max hold
2. Use the automatic bandwidth measurement capability of an instrument, may be employed using the X dB bandwidth mode with X set to 6 dB, care shall be taken so that the bandwidth measurement is not influenced by any intermediate power nulls in the fundamental emission that might be  $\geq$  6 dB.
3. Allow the trace to stabilize, record the X dB Bandwidth value.

#### Limit

Limit [kHz]

$\geq 500$

#### Test result

##### 802.11b

Frequency MHz	6dB bandwidth KHz	99 bandwidth KHz	Result
Bottom channel 2412MHz	10120	15744	Pass
Middle channel 2437MHz	10160	15305	Pass
Top channel 2462MHz	10120	15105	Pass

##### 802.11g

Frequency MHz	6dB bandwidth KHz	99 bandwidth KHz	Result
Bottom channel 2412MHz	16400	18102	Pass
Middle channel 2437MHz	16400	17902	Pass
Top channel 2462MHz	16400	17862	Pass

##### 802.11nHT20

Frequency MHz	6dB bandwidth KHz	99 bandwidth KHz	Result
Bottom channel 2412MHz	17400	19021	Pass
Middle channel 2437MHz	17400	18821	Pass
Top channel 2462MHz	17360	18781	Pass

802.11b

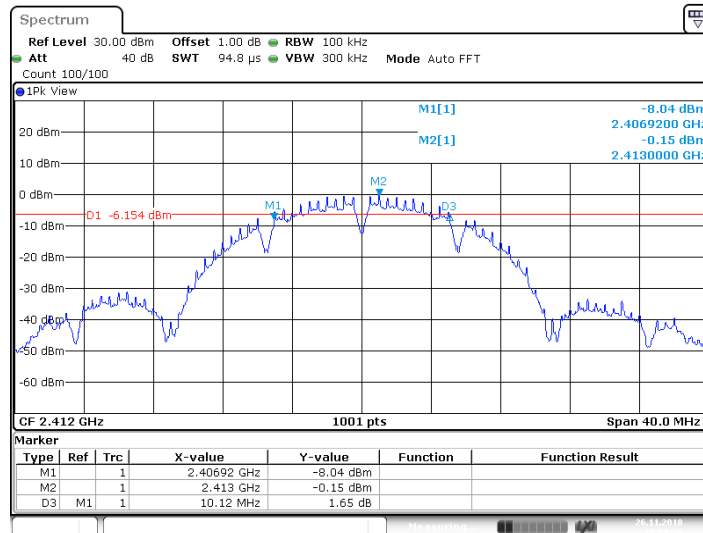

Date: 26 NOV 2018 15:08:56

2412MHz

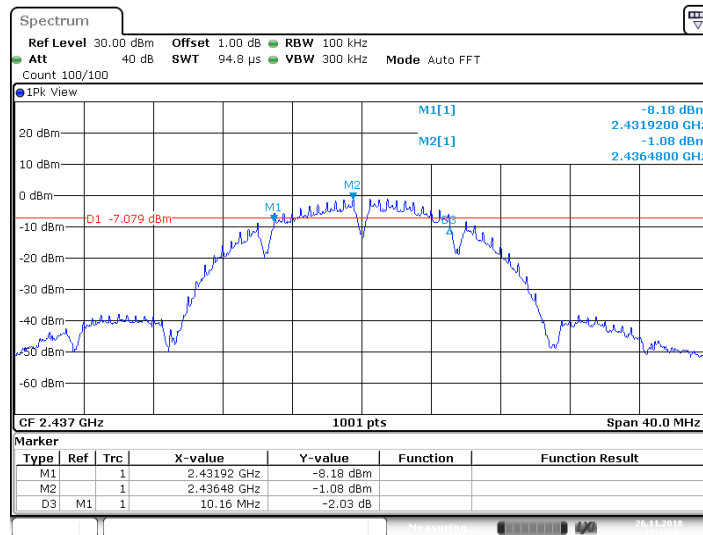

Date: 26 NOV 2018 15:14:42

2437MHz

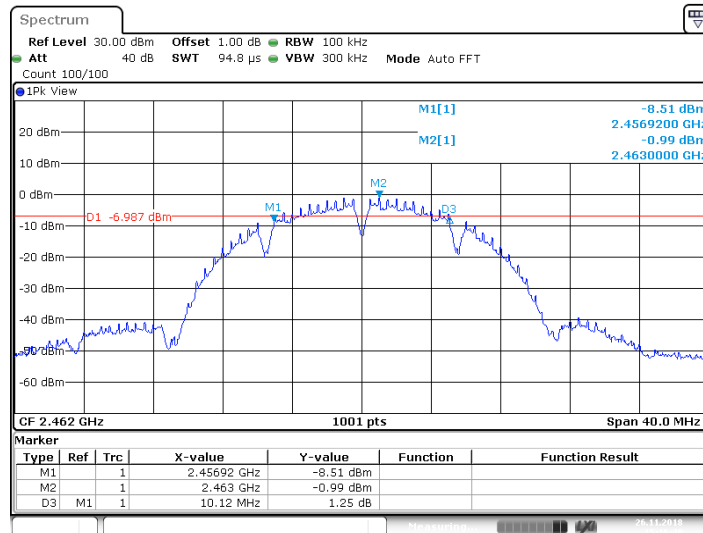

2462MHz

802.11g

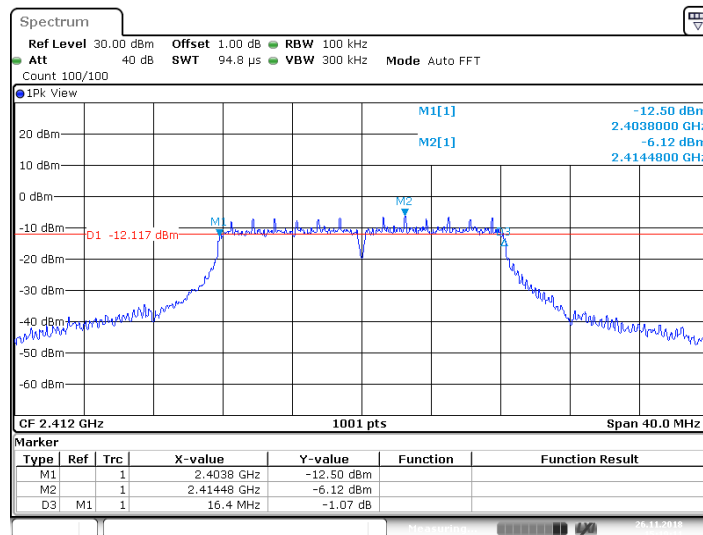

2412MHz



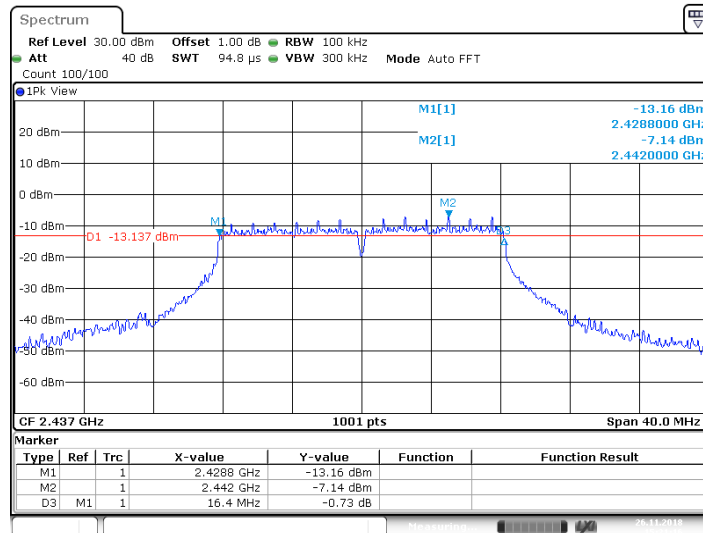

Date: 26 NOV 2018 15:21:16

2437MHz

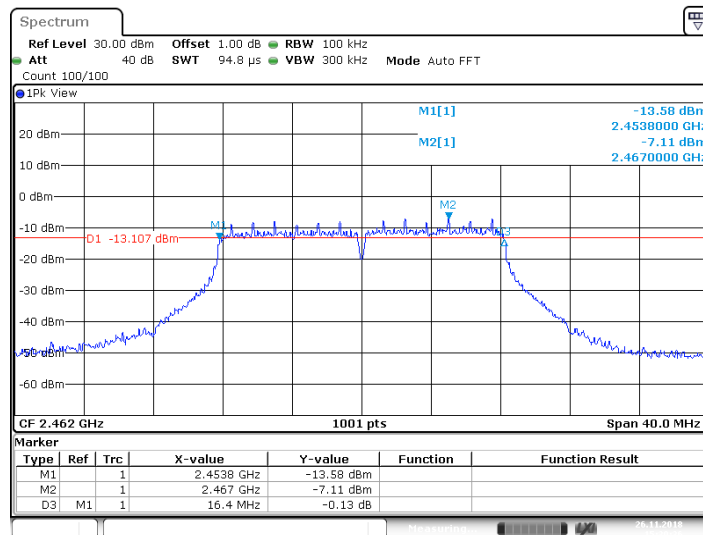

Date: 26 NOV 2018 15:30:37

2462MHz

802.11nHT20

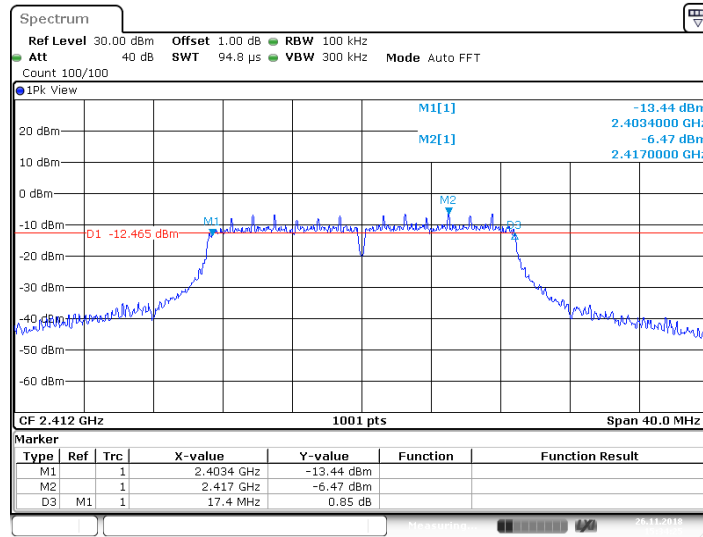

Date: 26 NOV 2018 15:34:26

2412MHz

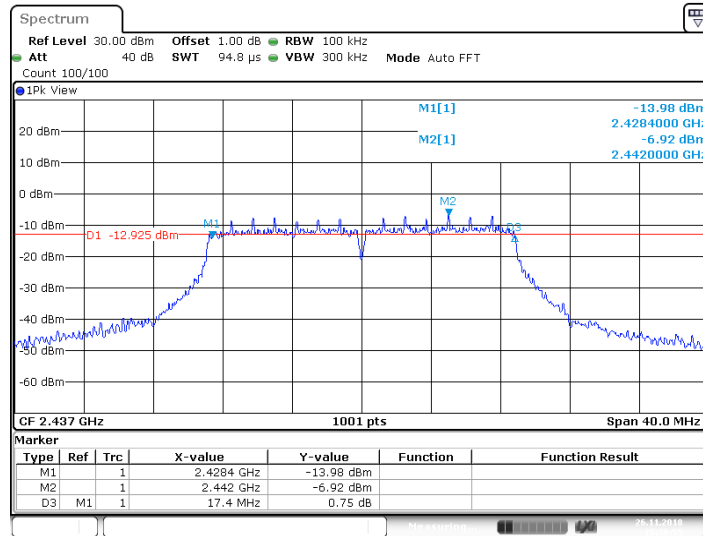

Date: 26 NOV 2018 15:36:56

2437MHz

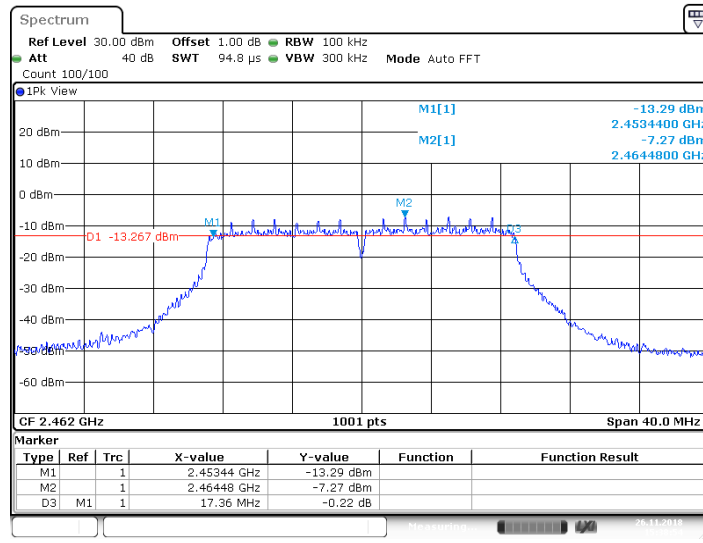

Date: 26 NOV 2018 15:38:54

2462MHz

802.11nHT40

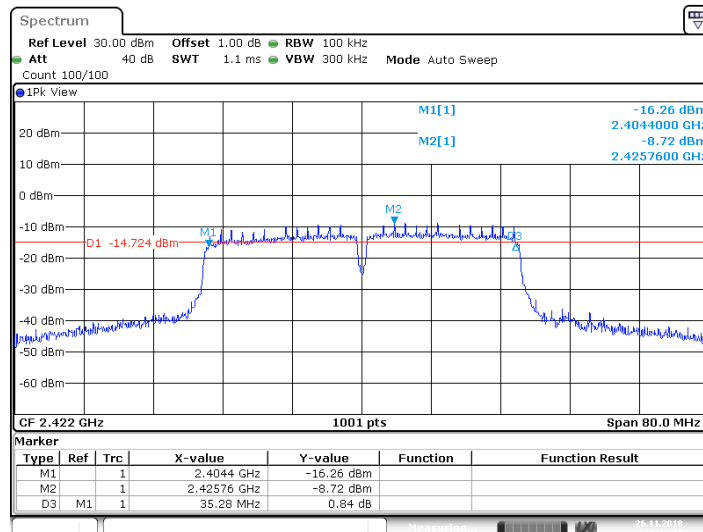

Date: 26 NOV 2018 15:42:32

2422MHz

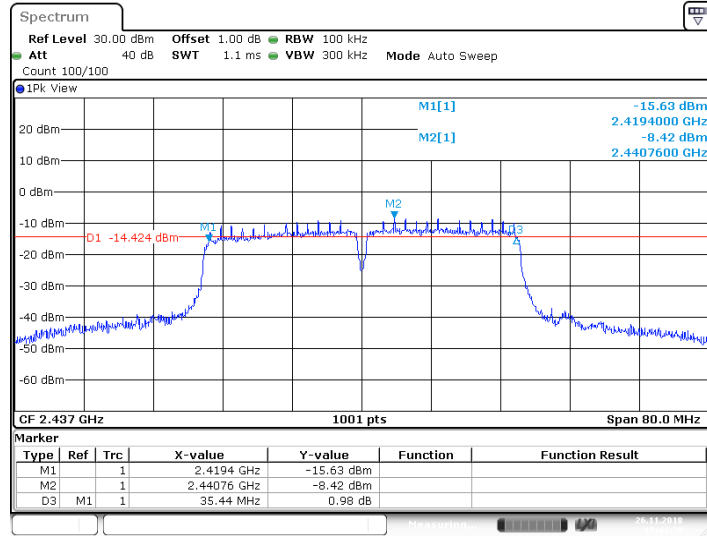

Date: 26 NOV 2018 15:44:30

2437MHz

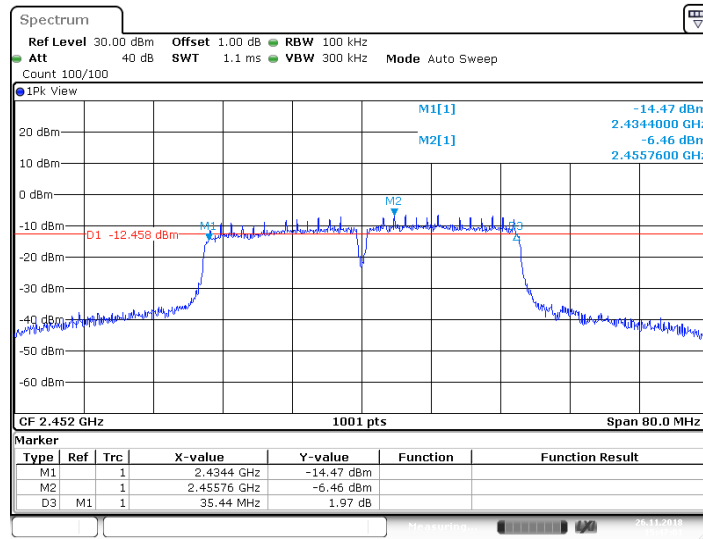

Date: 26 NOV 2018 15:47:01

2452MHz

## 9.4 Power spectral density

### Test Method

This procedure shall be used if maximum peak conducted output power was used to demonstrate compliance:

1. Set analyzer center frequency to DTS channel center frequency. RBW=3kHz, VBW $\geq$ 3RBW, Span=1.5 times DTS bandwidth, Detector=Peak, Sweep=auto, Trace= max hold.
2. Allow trace to fully stabilize, use the peak marker function to determine the maximum amplitude level within the RBW.
3. Repeat above procedures until other frequencies measured were completed.

### Limit

Limit [dBm]

$\leq 8$

### Test result

#### 802.11b

Frequency MHz	Power spectral density dBm	Result
Top channel 2412MHz	-14.13	Pass
Middle channel 2437MHz	-14.15	Pass
Bottom channel 2462MHz	-14.66	Pass

#### 802.11g

Frequency MHz	Power spectral density dBm	Result
Top channel 2412MHz	-19.78	Pass
Middle channel 2437MHz	-20.47	Pass
Bottom channel 2462MHz	-20.61	Pass

#### 802.11nHT20

Frequency MHz	Power spectral density dBm	Result
Top channel 2412MHz	-19.61	Pass
Middle channel 2437MHz	-19.07	Pass
Bottom channel 2462MHz	-19.61	Pass

802.11nHT40

Frequency MHz	Power spectral density dBm	Result
Top channel 2422MHz	-23.48	Pass
Middle channel 2437MHz	-23.09	Pass
Bottom channel 2452MHz	-18.59	Pass

802.11b

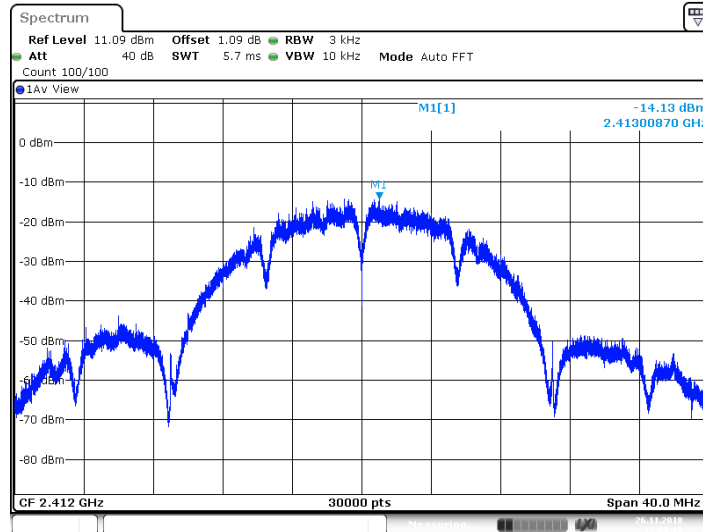

Date: 26 NOV 2018 15:09:20

2412MHz

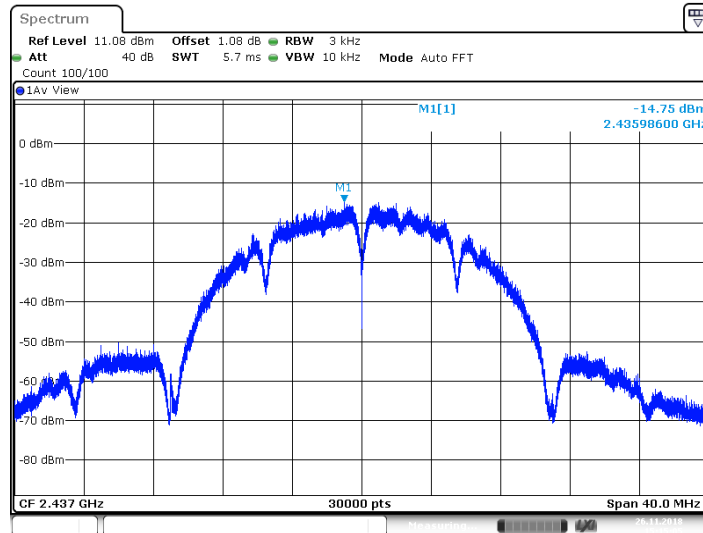

Date: 26 NOV 2018 15:15:06

2437MHz

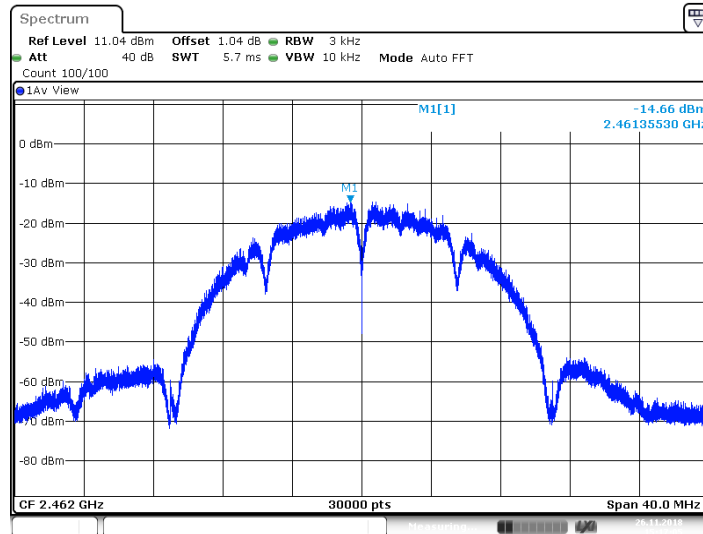

Date: 26 NOV 2018 15:17:05

2462MHz

802.11g

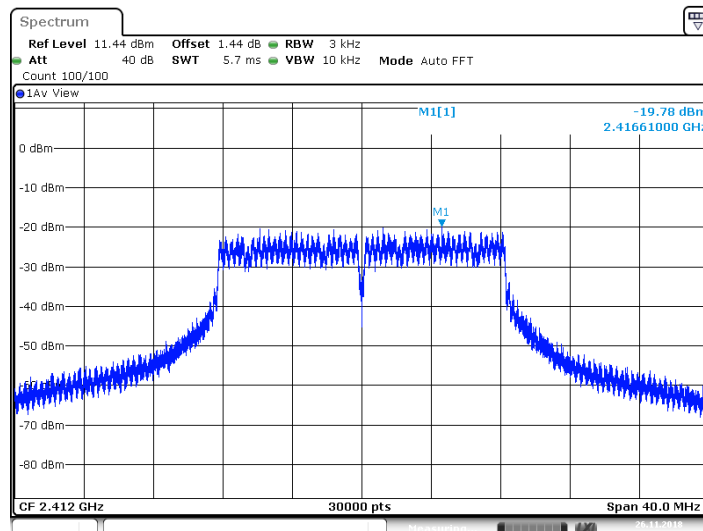

Date: 26 NOV 2018 15:19:35

2412MHz



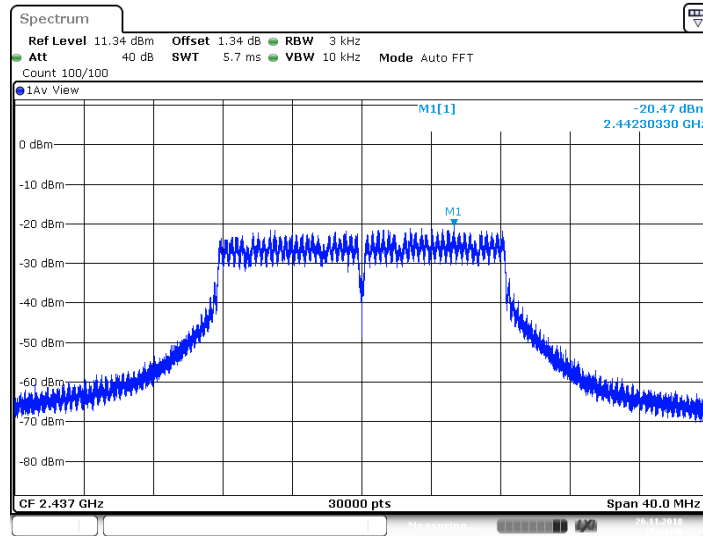

2437MHz

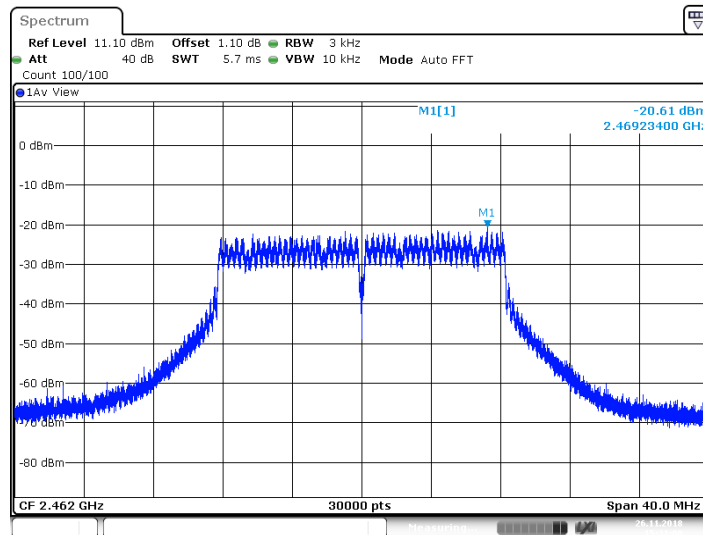

2462MHz

802.11nHT20

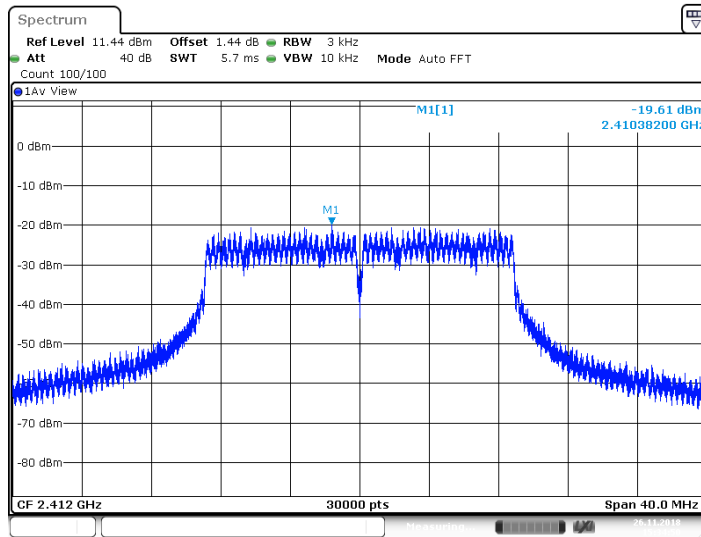

2412MHz

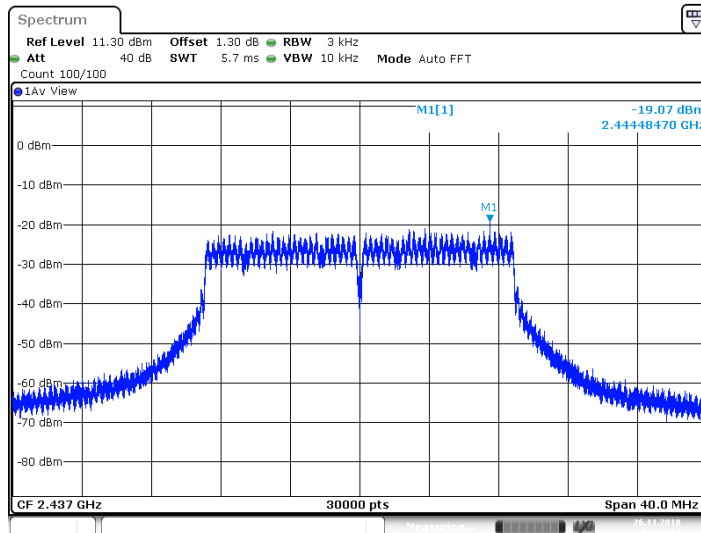

2437MHz

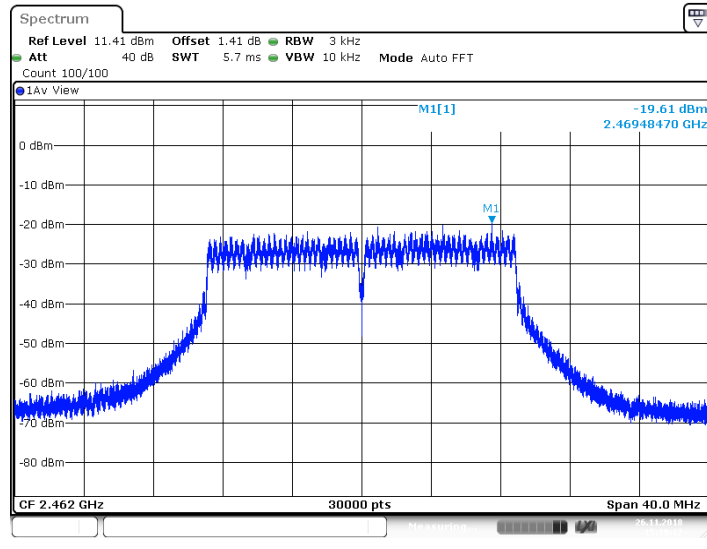

2462MHz

802.11nHT40

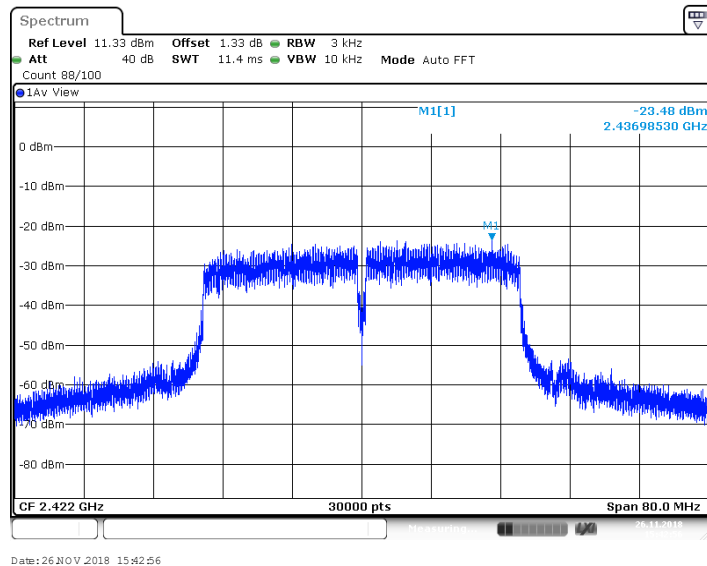

2422MHz

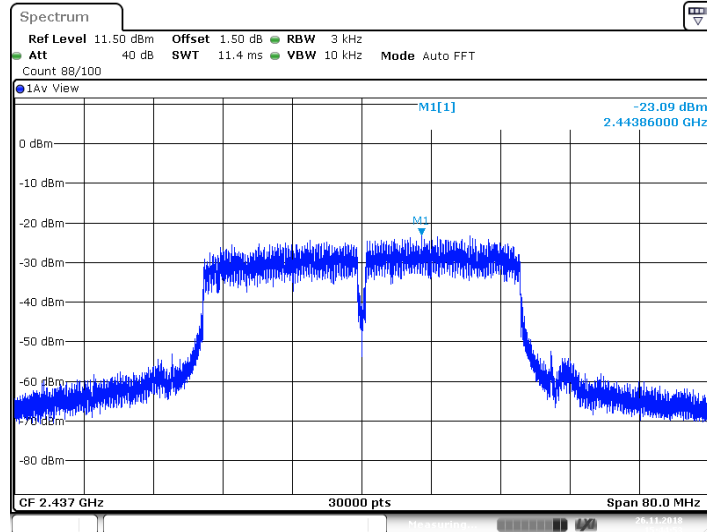

Date: 26 NOV 2018 15:44:54

2437MHz

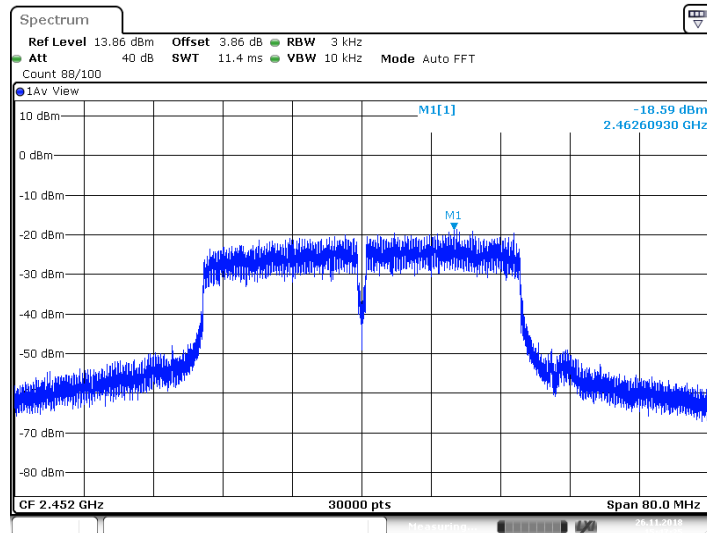

Date: 26 NOV 2018 15:47:25

2462MHz

## 9.5 Spurious RF conducted emissions

### Test Method

1. Establish a reference level by using the following procedure:
  - a. Set RBW=100 kHz. VBW $\geq$ 3RBW. Detector =peak, Sweep time = auto couple, Trace mode = max hold.
  - b. Allow trace to fully stabilize, use the peak marker function to determine the maximum PSD level.
2. Use the maximum PSD level to establish the reference level.
  - a. Set the center frequency and span to encompass frequency range to be measured.
  - b. Use the peak marker function to determine the maximum amplitude level. Ensure that the amplitude of all unwanted emissions outside of the authorized frequency band (excluding restricted frequency bands) are attenuated by at least the minimum requirements, report the three highest emissions relative to the limit.
3. Repeat above procedures until other frequencies measured were completed.

### Limit

Frequency Range MHz	Limit (dBc)
30-25000	-20

### Spurious RF conducted emissions

802.11b

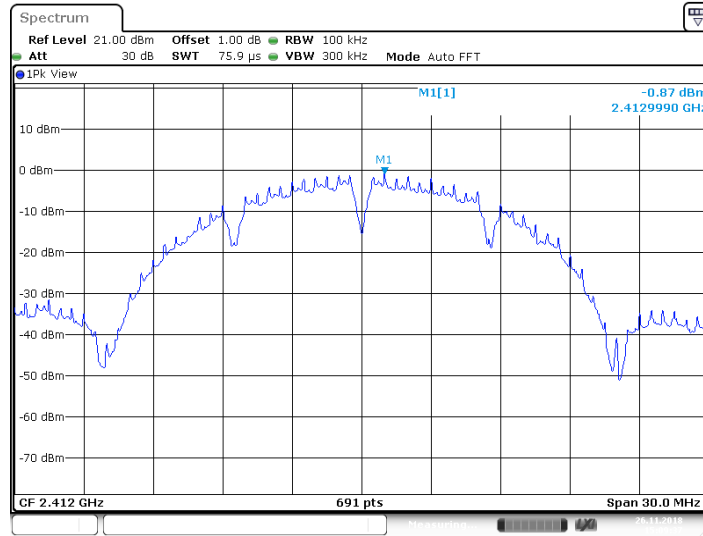

Date: 26 NOV 2018 15:09:37

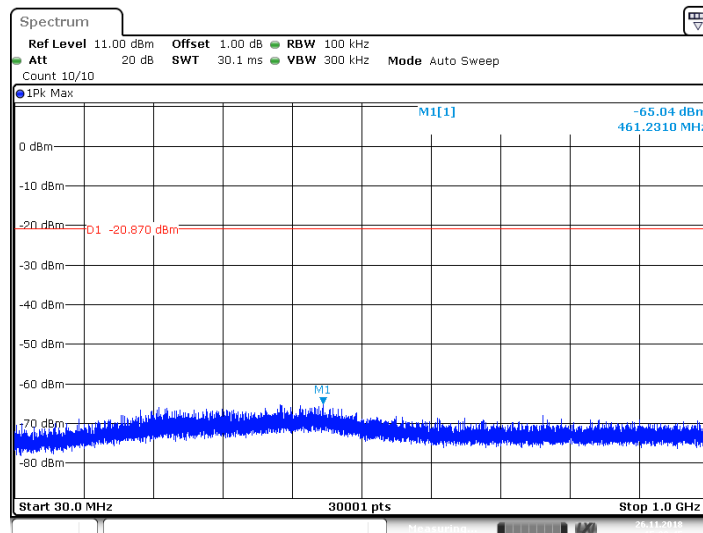

Date: 26 NOV 2018 15:09:45

2412MHz

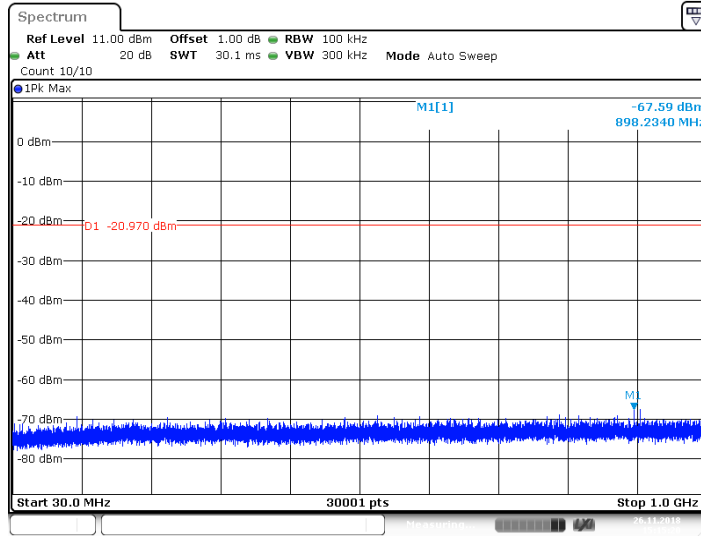

Date: 26 NOV 2018 15:15:20

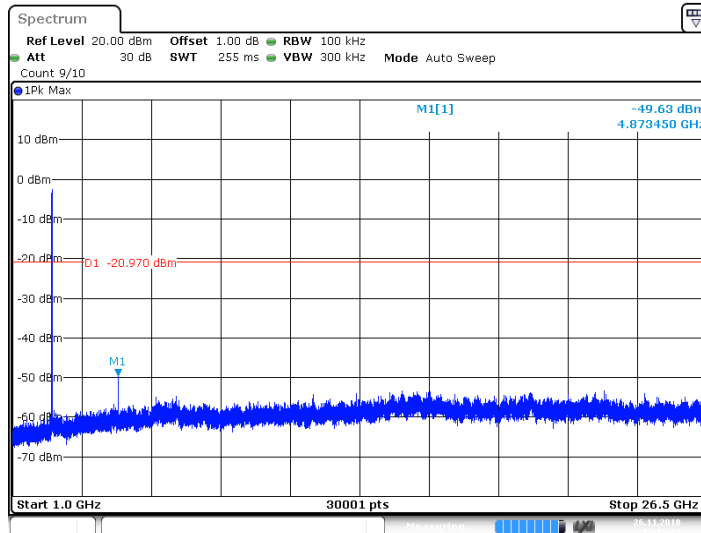

Date: 26 NOV 2018 15:15:32

2437MHz

### Spurious RF conducted emissions

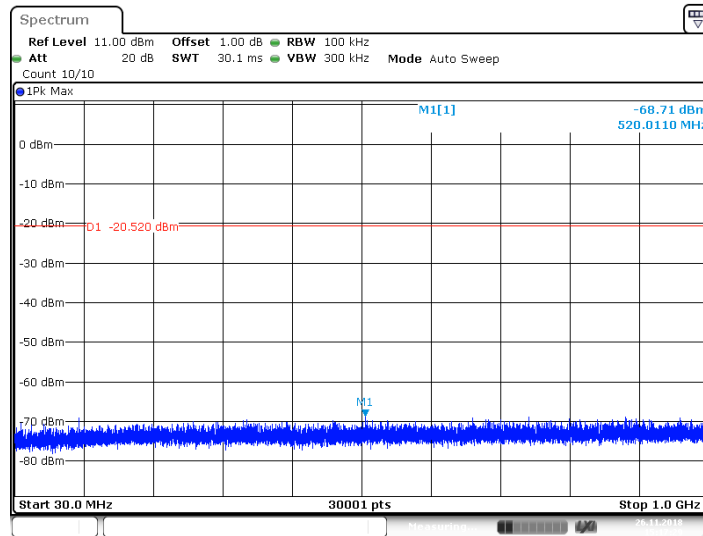

Date: 26 NOV 2018 15:17:30

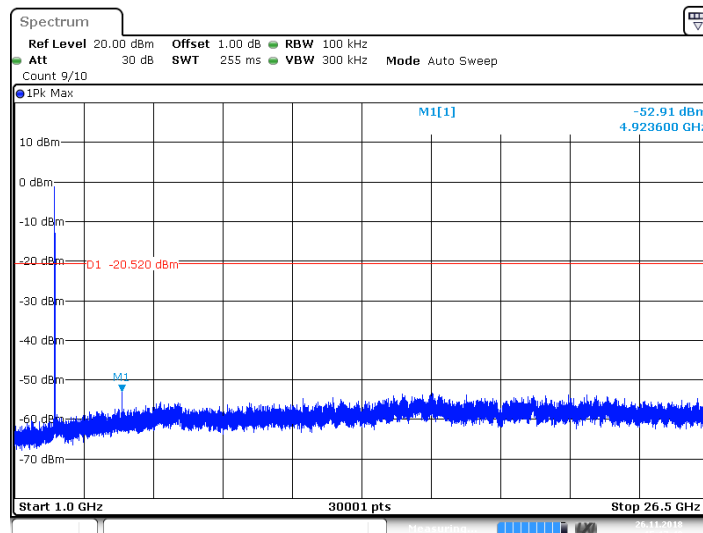

Date: 26 NOV 2018 15:17:41

2462MHz



802.11g

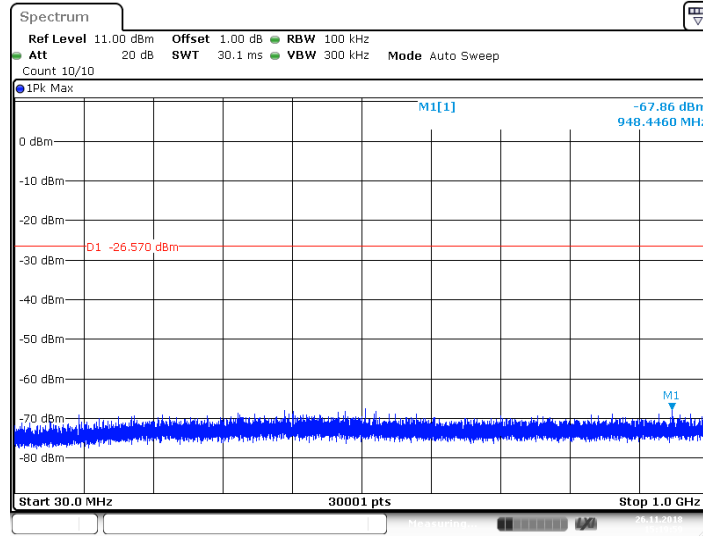

Date: 26 NOV 2018 15:20:00

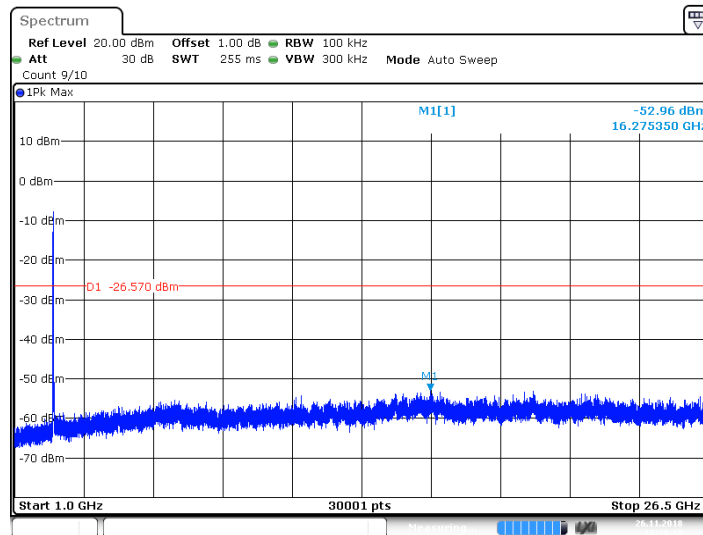

Date: 26 NOV 2018 15:20:11

2412MHz

### Spurious RF conducted emissions

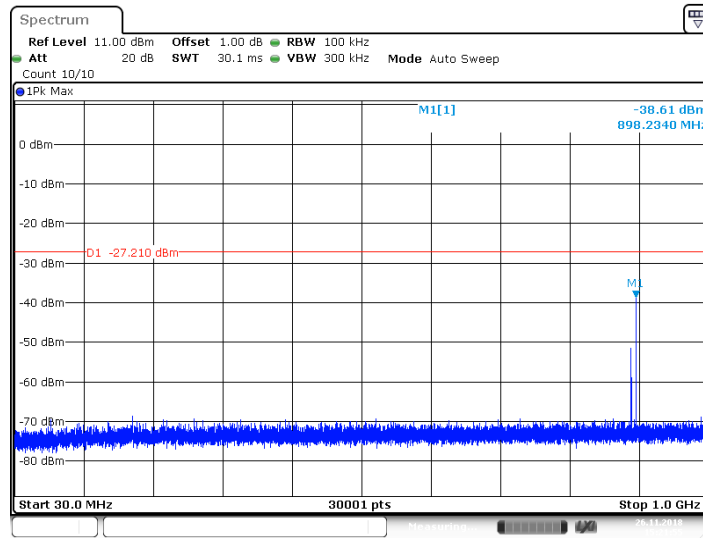

Date: 26 NOV 2018 15:21:55

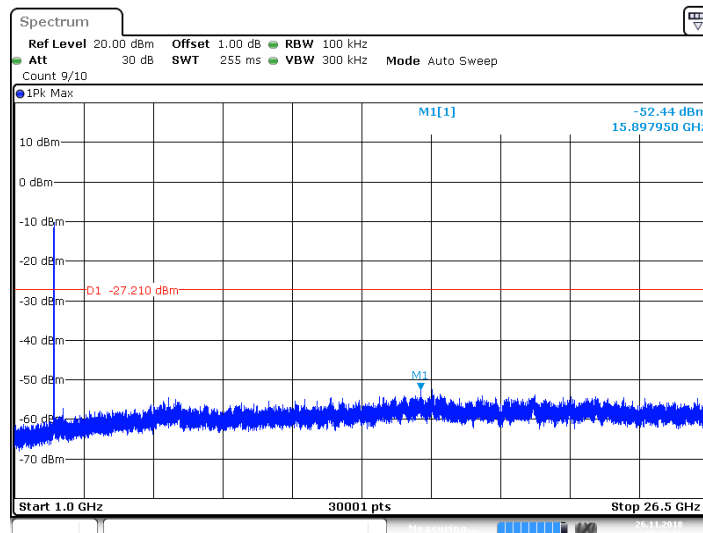

Date: 26 NOV 2018 15:22:07

2437MHz

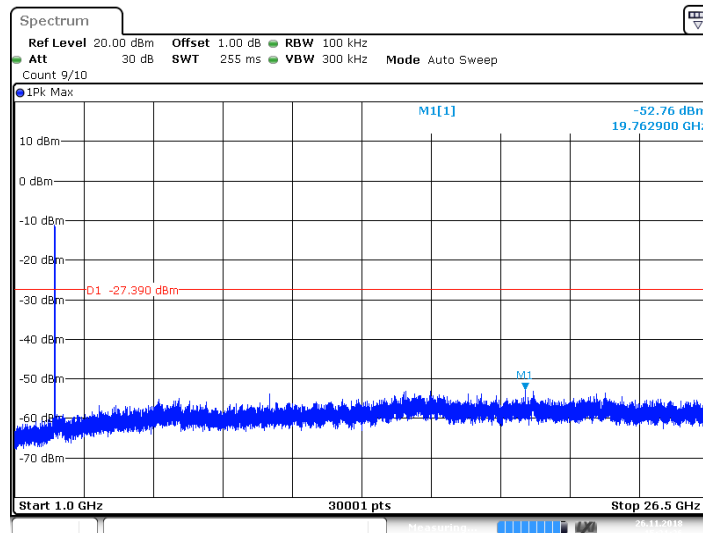
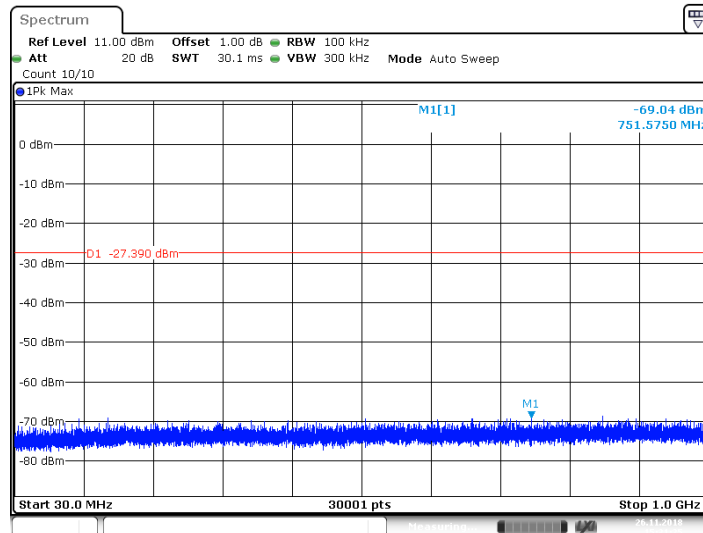

2462MHz

## Spurious RF conducted emissions

802.11nHT20

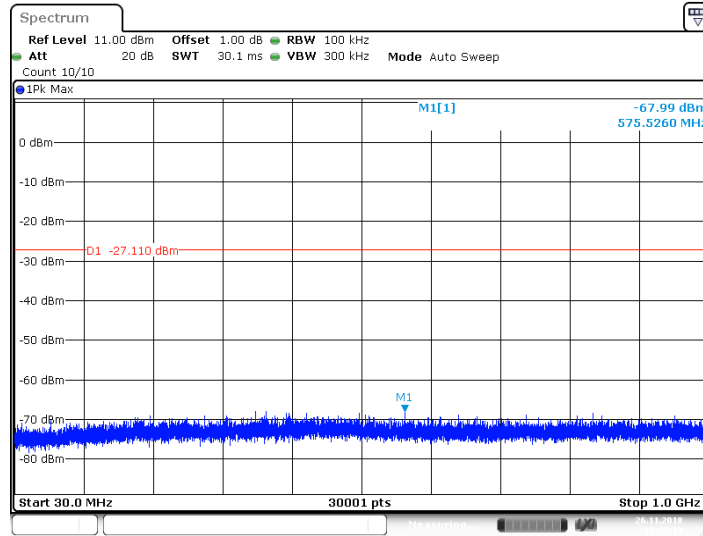

Date: 26 NOV 2018 15:35:14

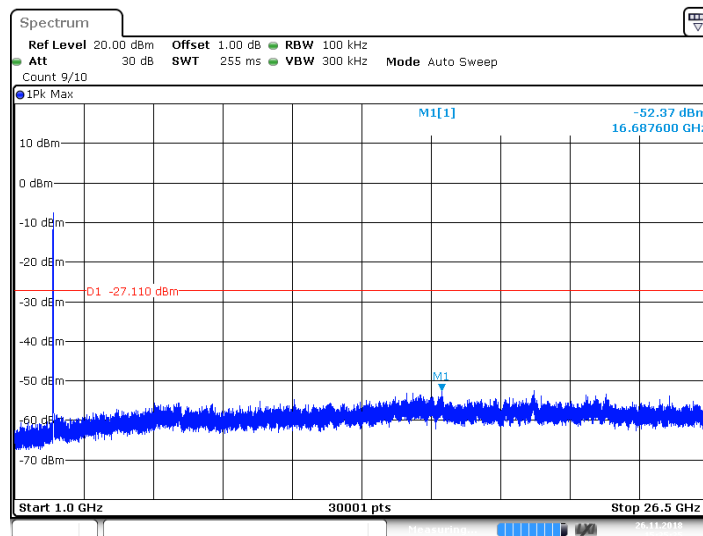

Date: 26 NOV 2018 15:35:25

2412MHz

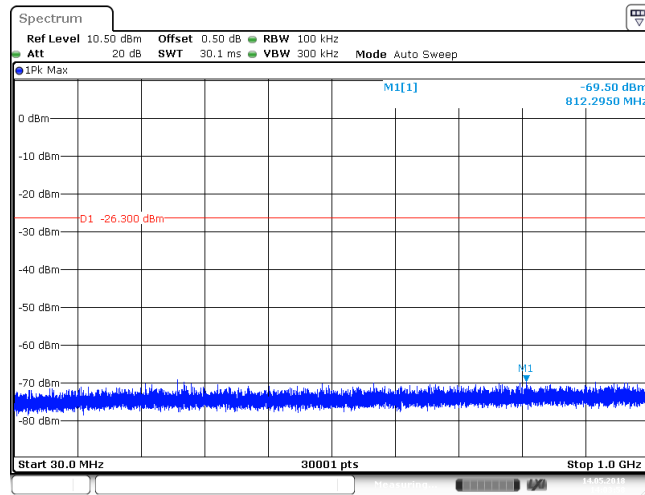

Date: 14 MAY 2018 14:03:58

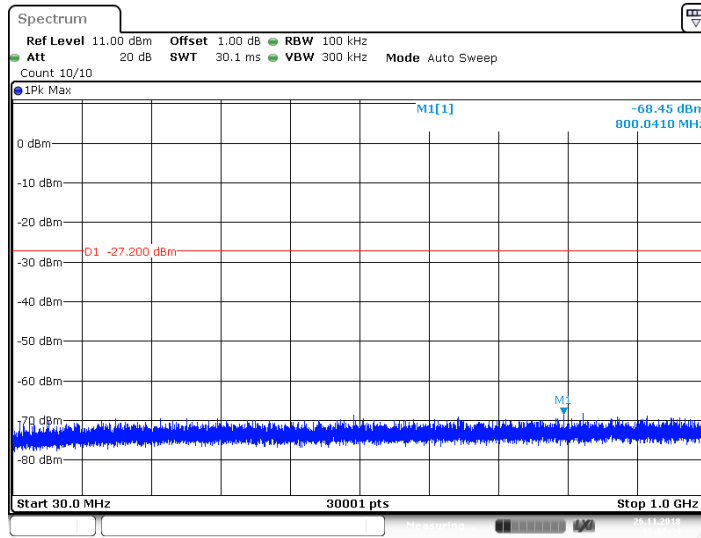

Date: 26 NOV 2018 15:37:34

2437MHz

### Spurious RF conducted emissions

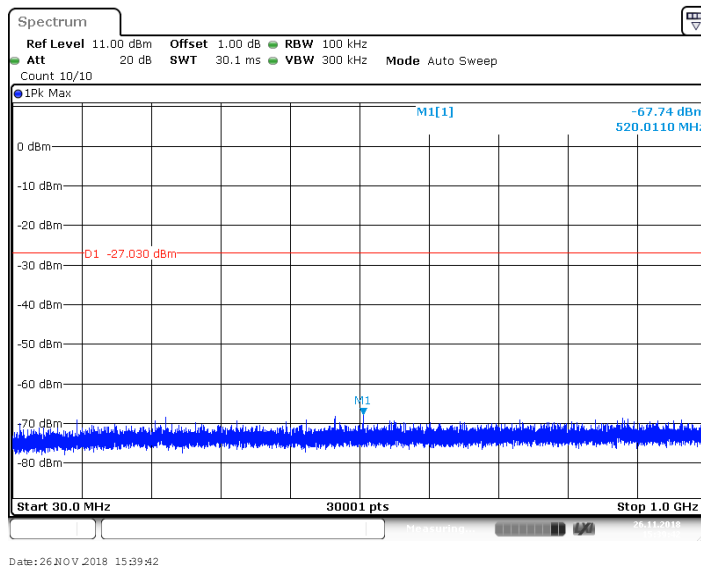
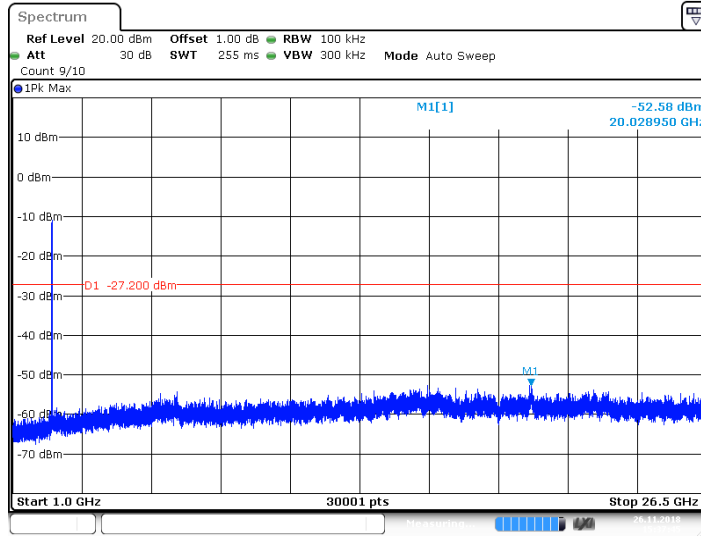

2462MHz

### Spurious RF conducted emissions

802.11nHT40

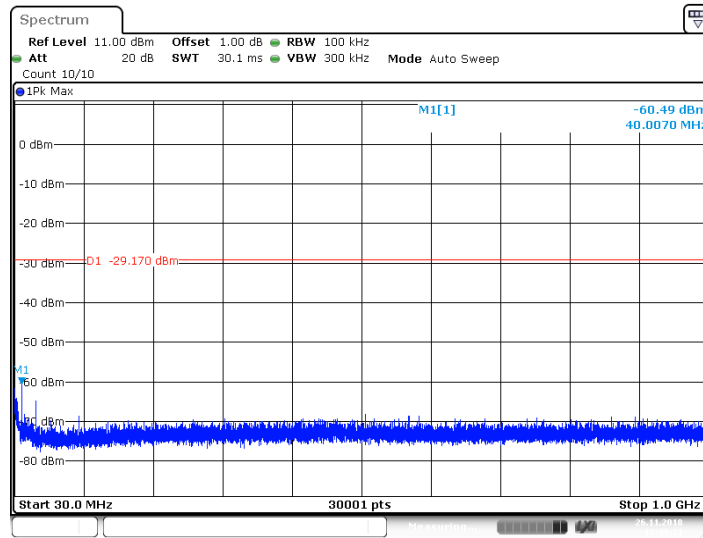

Date: 26 NOV 2018 15:43:21

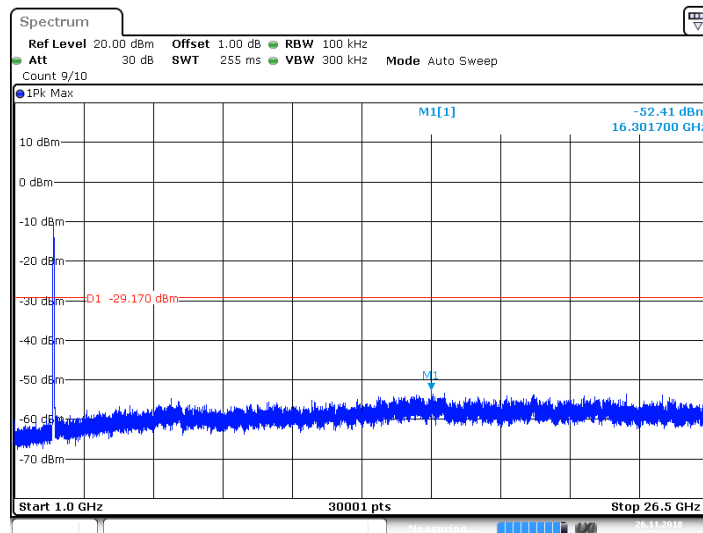

Date: 26 NOV 2018 15:43:32

2412MHz

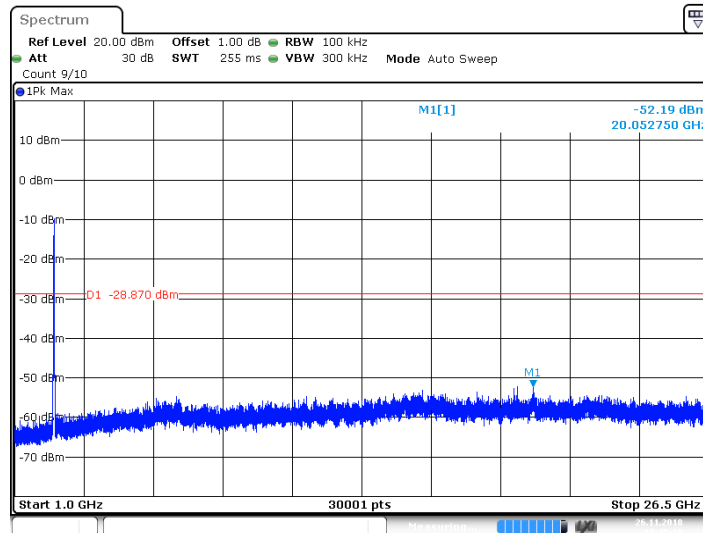
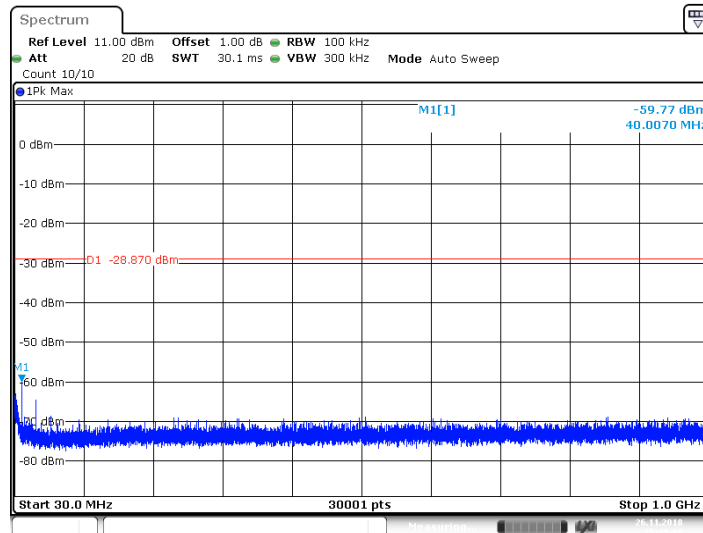

2437MHz



### Spurious RF conducted emissions

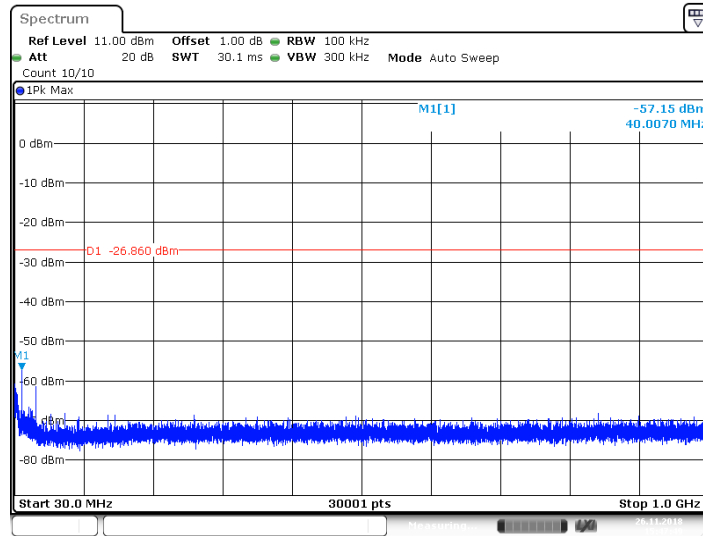

Date: 26 NOV 2018 15:47:50

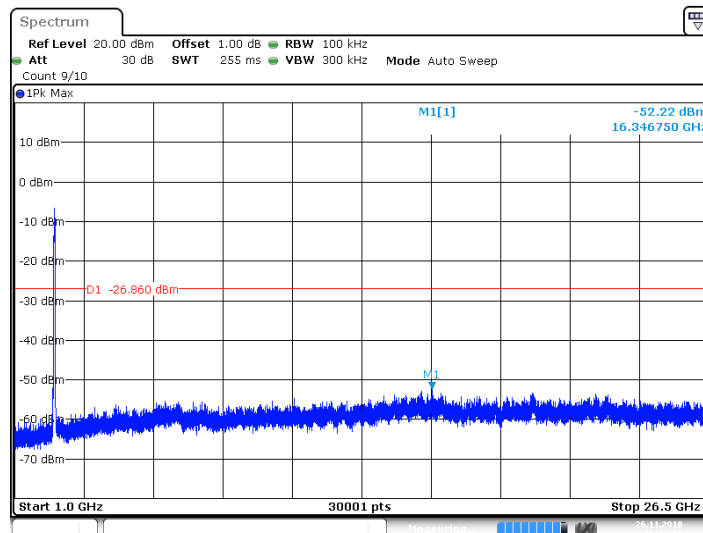

Date: 26 NOV 2018 15:48:01

2452MHz

## 9.6 Band edge

### Test Method

- 1 Use the following spectrum analyzer settings:  
Span = wide enough to capture the peak level of the in-band emission and all spurious  
RBW = 100 kHz, VBW  $\geq$  RBW, Sweep = auto, Detector function = peak, Trace = max hold.
- 2 Allow the trace to stabilize, use the peak and delta measurement to record the result.
- 3 The level displayed must comply with the limit specified in this Section.

### Limit

Frequency Range	Limit (dBc)
MHz	
30-25000	-20

### Test result

802.11b

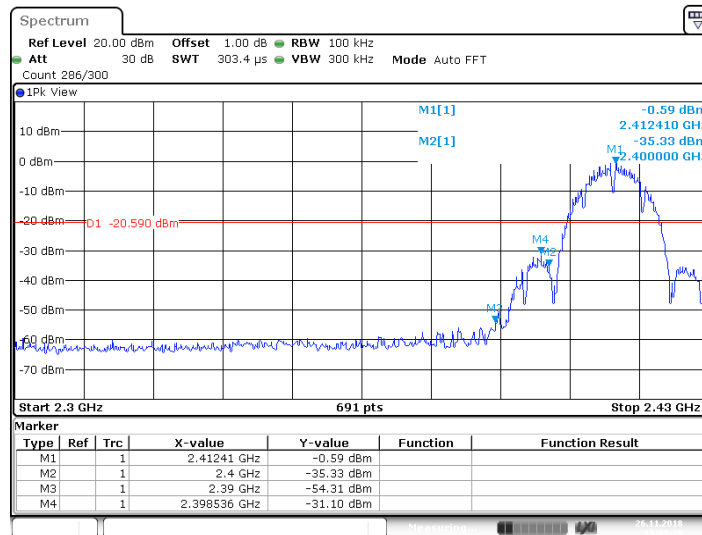

Date: 26 NOV 2018 15:09:30

2412MHz

**Band edge**

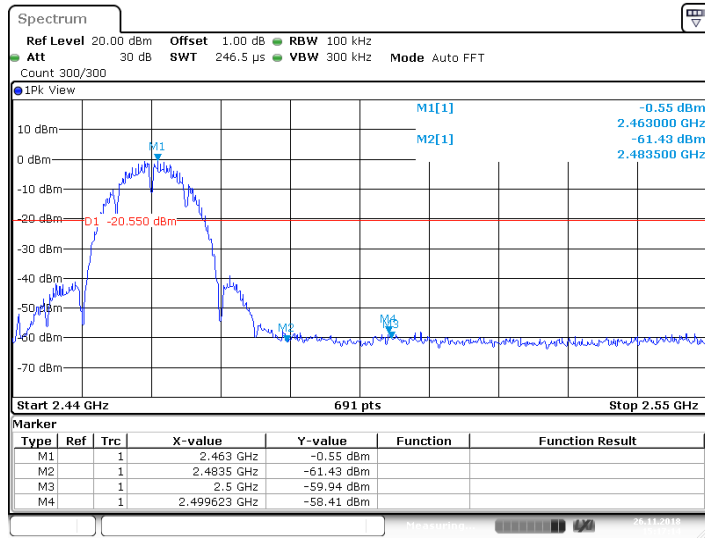

Date: 26 NOV 2018 15:17:15

2462MHz

802.11g

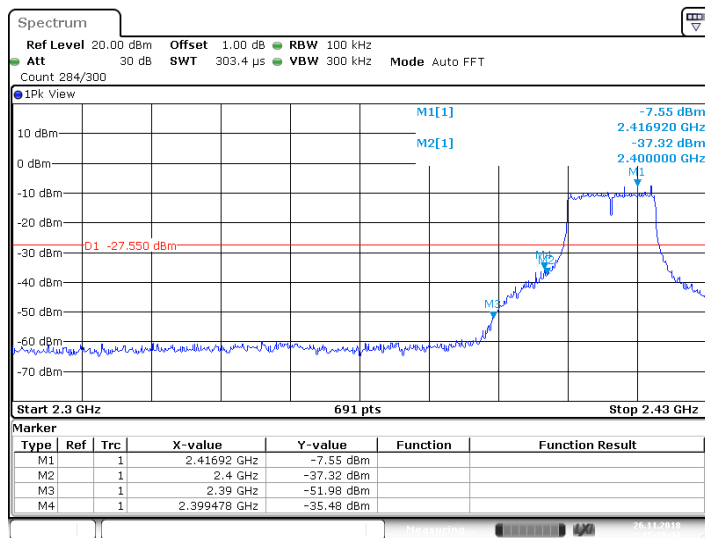

Date: 26 NOV 2018 15:19:45

2412MHz

**Band edge**

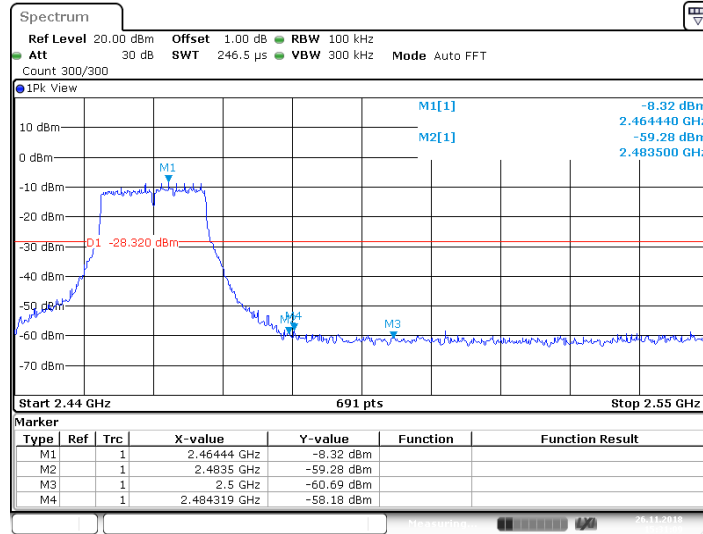

Date: 26 NOV 2018 15:31:10

2462MHz

802.11nHT20

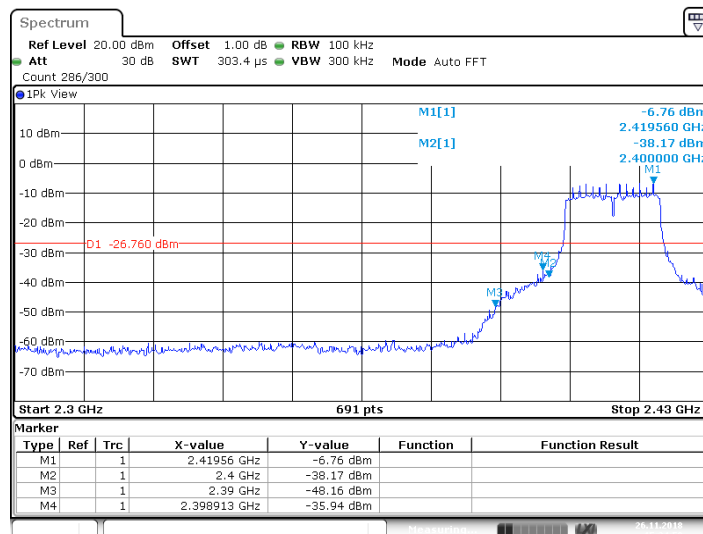

Date: 26 NOV 2018 15:34:59

2412MHz

**Band edge**

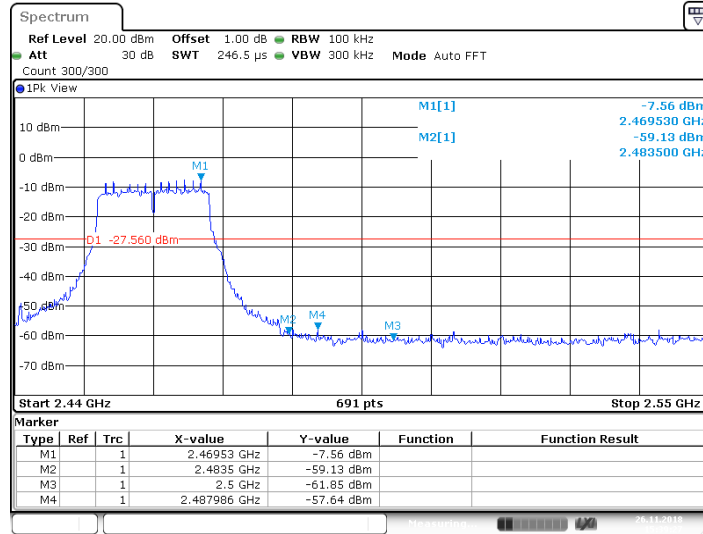

Date: 26 NOV 2018 15:39:27

2462MHz

802.11nHT40

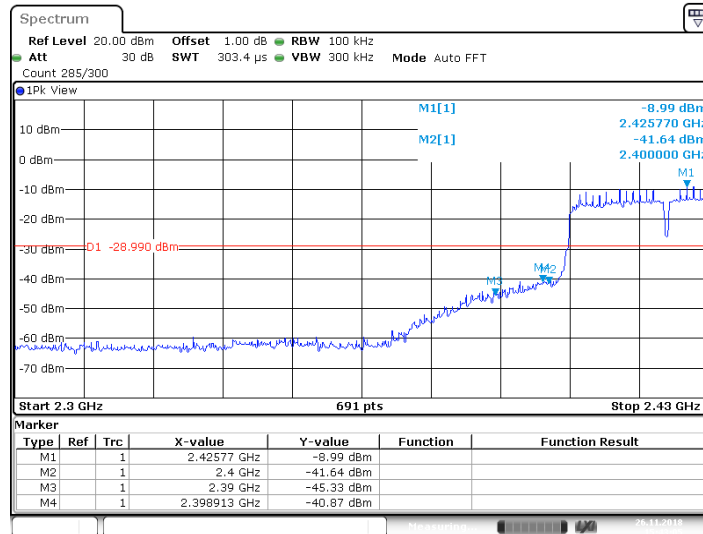

Date: 26 NOV 2018 15:43:06

2422MHz

**Band edge**

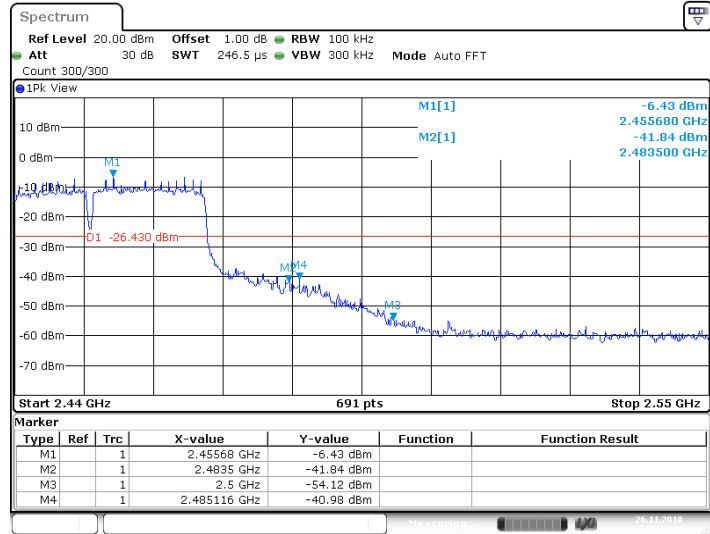

Date: 26 NOV 2018 15:47:35

2452MHz

## 9.7 Spurious radiated emissions for transmitter

### Test Method

- 1: The EUT was placed on a turn table which is 1.5m above ground plane for above 1GHz and 0.8m above ground for below 1GHz at 3meter chamber room for test. The table was rotated 360 degrees to determine the position of the highest radiation.
- 2: The EUT was set 3 meters away from the interference – receiving antenna, which was mounted on the top of a variable – height antenna tower.
- 3: The height of antenna is varied from one meter to four meters above the ground to determine the maximum value of the field strength. Both horizontal and vertical polarizations of the antenna are set to make the measurement.
- 4: For each suspected emission, the EUT was arranged to its worst case and then the antenna was tuned to heights from 1 meter to 4 meters and the rotatable table was turned from 0 degrees to 360 degrees to find the maximum reading.

5: Use the following spectrum analyzer settings According to C63.10:

For Above 1GHz

Span = wide enough to capture the peak level of the in-band emission and all spurious  
RBW = 1MHz, VBW  $\geq$  RBW for peak measurement and VBW = 10Hz for average measurement, Sweep = auto, Detector function = peak, Trace = max hold.

For Below 1GHz

Use the following spectrum analyzer settings:

Span = wide enough to capture the peak level of the in-band emission and all spurious  
RBW = 100 KHz, VBW  $\geq$  RBW for peak measurement, Sweep = auto, Detector function = peak, Trace = max hold.

### Note:

- 1: The resolution bandwidth and video bandwidth of test receiver/spectrum analyzer is 120 KHz for Quasi-peak detection (QP) at frequency below 1GHz.
- 2: The resolution bandwidth of test receiver/spectrum analyzer is 1MHz and the video bandwidth is 3MHz for peak detection (PK) at frequency above 1GHz.
- 3: The resolution bandwidth of test receiver/spectrum analyzer is 1MHz and the video bandwidth is 3MHz for RMS Average ((duty cycle < 98%) for Average detection (AV) at frequency above 1GHz, then the measurement results was added to a correction factor ( $20\log(1/\text{duty cycle})$ ).
- 4: The resolution bandwidth of test receiver/spectrum analyzer is 1MHz and the video bandwidth is 10Hz (duty cycle > 98%) for Average detection (AV) at frequency above 1GHz.

## Limit

The radio emission outside the operating frequency band shall be at least 20 dB below that in the 100 kHz bandwidth within the band that contains the highest level of the desired power. Radiated emissions which fall in the restricted bands, as defined in section 15.205, must comply with the radiated emission limits specified in section 15.209.

Frequency MHz	Field Strength uV/m	Field Strength dB $\mu$ V/m	Detector
30-88	100	40	QP
88-216	150	43.5	QP
216-960	200	46	QP
960-1000	500	54	QP
Above 1000	500	54	AV
Above 1000	5000	74	PK





**Spurious radiated emissions for transmitter**

According to C63.10, if the peak (or quasi-peak) measured value complies with the average limit, it is unnecessary to perform an average measurement, so AV emission value did not show in below table if the peak value complies with average limit.

**Transmitting spurious emission test result as below:**

802.11b

2412MHz (30MHz – 1GHz)

Frequency MHz	Emission Level dBuV/m	Polarization	Limit dBµV/m	Detector	Result	Corr. (dB)
475.23	39.98	Horizontal	46.00	QP	Pass	-21.7
39.91	36.39	Vertical	46.00	QP	Pass	-21.4

2412MHz (Above 1GHz)

Frequency MHz	Emission Level dBuV/m	Polarization	Limit dBµV/m	Detector	Result	Corr. (dB)
4823.90*	51.22	Horizontal	74.00	PK	Pass	3.9
4823.90*	51.22	Horizontal	54.00	AV	Pass	3.9
4823.90*	53.25	Vertical	74.00	PK	Pass	3.9
4823.90*	53.25	Vertical	54.00	AV	Pass	3.9

Remark:

- (1) Data of measurement within this frequency range shown “-” in the table above means the reading of emissions are attenuated more than 20db below the permissible limits or the field strength is too small to be measured.
- (2) “\*” means the emission(s) appear within the restrict bands shall follow the requirement of section 15.205.
- (3) Above 1GHz: Corrector factor = Antenna Factor + Cable Loss- Amplifier Gain
- (4) Below 1GHz: Corrector factor = Antenna Factor + Cable Loss



2437MHz (30MHz – 1GHz)

Frequency MHz	Emission Level dBuV/m	Polarization	Limit dBµV/m	Detector	Result
--	--	Horizontal	--	QP	Pass
--	--	Vertical	--	QP	Pass

2437MHz (Above 1GHz)

Frequency MHz	Emission Level dBuV/m	Polarization	Limit dBµV/m	Detector	Result	Corr. (dB)
15888.17*	49.12	Horizontal	74.00	PK	Pass	19.3
12331.87*	44.40	Vertical	74.00	PK	Pass	14.0

Remark:

- (1) Data of measurement within this frequency range shown “-” in the table above means the reading of emissions are attenuated more than 20db below the permissible limits or the field strength is too small to be measured.
- (2) “\*” means the emission(s) appear within the restrict bands shall follow the requirement of section 15.205.
- (3) Above 1GHz: Corrector factor = Antenna Factor + Cable Loss- Amplifier Gain
- (4) Below 1GHz: Corrector factor = Antenna Factor + Cable Loss

2462MHz (30MHz – 1GHz)

Frequency MHz	Emission Level dBuV/m	Polarization	Limit dBµV/m	Detector	Result
--	--	Horizontal	--	QP	Pass
--	--	Vertical	--	QP	Pass

2462MHz (Above 1GHz)

Frequency MHz	Emission Level dBuV/m	Polarization	Limit dBµV/m	Detector	Result	Corr. (dB)
4923.75*	45.22	Horizontal	74.00	PK	Pass	4.5
4923.77*	49.80	Vertical	74.00	PK	Pass	4.5

Remark:

- (1) Data of measurement within this frequency range shown “-” in the table above means the reading of emissions are attenuated more than 20db below the permissible limits or the field strength is too small to be measured.
- (2) “\*” means the emission(s) appear within the restrict bands shall follow the requirement of section 15.205.
- (3) Above 1GHz: Corrector factor = Antenna Factor + Cable Loss- Amplifier Gain
- (4) Below 1GHz: Corrector factor = Antenna Factor + Cable Loss



802.11g  
2412MHz (30MHz – 1GHz)

Frequency MHz	Emission Level dBuV/m	Polarization	Limit dBµV/m	Detector	Result
		Horizontal		QP	Pass
		Vertical		QP	Pass

2412MHz (Above 1GHz)

Frequency MHz	Emission Level dBuV/m	Polarization	Limit dBµV/m	Detector	Result	Corr. (dB)
4819.68*	45.39	Horizontal	74.00	PK	Pass	3.8
4818.75*	48.50	Vertical	74.00	PK	Pass	3.8

Remark:

- (1) Data of measurement within this frequency range shown “-” in the table above means the reading of emissions are attenuated more than 20db below the permissible limits or the field strength is too small to be measured.
- (2) “\*” means the emission(s) appear within the restrict bands shall follow the requirement of section 15.205.
- (3) Above 1GHz: Corrector factor = Antenna Factor + Cable Loss- Amplifier Gain
- (4) Below 1GHz: Corrector factor = Antenna Factor + Cable Loss

2437MHz (30MHz – 1GHz)

Frequency MHz	Emission Level dBuV/m	Polarization	Limit dBµV/m	Detector	Result
--	--	Horizontal	--	QP	Pass
--	--	Vertical	--	QP	Pass

2437MHz (Above 1GHz)

Frequency MHz	Emission Level dBuV/m	Polarization	Limit dBµV/m	Detector	Result	Corr. (dB)
4874.06*	43.88	Horizontal	74.00	PK	Pass	3.8
4877.80*	45.25	Vertical	74.00	PK	Pass	3.8

Remark:

- (1) Data of measurement within this frequency range shown “-” in the table above means the reading of emissions are attenuated more than 20db below the permissible limits or the field strength is too small to be measured.
- (2) “\*” means the emission(s) appear within the restrict bands shall follow the requirement of section 15.205.
- (3) Above 1GHz: Corrector factor = Antenna Factor + Cable Loss- Amplifier Gain
- (4) Below 1GHz: Corrector factor = Antenna Factor + Cable Loss



2462MHz (30MHz – 1GHz)

Frequency MHz	Emission Level dBuV/m	Polarization	Limit dBµV/m	Detector	Result
--	--	Horizontal	--	QP	Pass
--	--	Vertical	--	QP	Pass

2462MHz (Above 1GHz)

Frequency MHz	Emission Level dBuV/m	Polarization	Limit dBµV/m	Detector	Result	Corr. (dB)
4926.56*	40.12	Horizontal	74.00	PK	Pass	4.2
4924.21*	42.66	Vertical	74.00	PK	Pass	4.2

Remark:

- (1) Data of measurement within this frequency range shown “-” in the table above means the reading of emissions are attenuated more than 20db below the permissible limits or the field strength is too small to be measured.
- (2) “\*” means the emission(s) appear within the restrict bands shall follow the requirement of section 15.205.
- (3) Above 1GHz: Corrector factor = Antenna Factor + Cable Loss- Amplifier Gain
- (4) Below 1GHz: Corrector factor = Antenna Factor + Cable Loss

802.11nHT20

2412MHz (30MHz – 1GHz)

Frequency MHz	Emission Level dBuV/m	Polarization	Limit dBµV/m	Detector	Result
--	--	Horizontal	--	QP	Pass
--	--	Vertical	--	QP	Pass

2412MHz (Above 1GHz)

Frequency MHz	Emission Level dBuV/m	Polarization	Limit dBµV/m	Detector	Result	Corr. (dB)
1440.00*	44.83	Horizontal	74.00	PK	Pass	-11.2
1440.00*	44.85	Vertical	74.00	PK	Pass	-11.2

Remark:

- (1) Data of measurement within this frequency range shown “-” in the table above means the reading of emissions are attenuated more than 20db below the permissible limits or the field strength is too small to be measured.
- (2) “\*” means the emission(s) appear within the restrict bands shall follow the requirement of section 15.205.
- (3) Above 1GHz: Corrector factor = Antenna Factor + Cable Loss- Amplifier Gain
- (4) Below 1GHz: Corrector factor = Antenna Factor + Cable Loss

## 2437MHz (30MHz – 1GHz)

Frequency MHz	Emission Level dBuV/m	Polarization	Limit dBμV/m	Detector	Result
--	--	Horizontal	--	QP	Pass
--	--	Vertical	--	QP	Pass

## 2437MHz (Above 1GHz)

Frequency MHz	Emission Level dBuV/m	Polarization	Limit dBμV/m	Detector	Result	Corr. (dB)
1991.56*	34.34	Horizontal	74.00	PK	Pass	-8.9
2138.00*	35.26	Vertical	74.00	PK	Pass	-7.6

## Remark:

- (1) Data of measurement within this frequency range shown “-” in the table above means the reading of emissions are attenuated more than 20db below the permissible limits or the field strength is too small to be measured.
- (2) “\*” means the emission(s) appear within the restrict bands shall follow the requirement of section 15.205.
- (3) Above 1GHz: Corrector factor = Antenna Factor + Cable Loss- Amplifier Gain
- (4) Below 1GHz: Corrector factor = Antenna Factor + Cable Loss

## 2462MHz (30MHz – 1GHz)

Frequency MHz	Emission Level dBuV/m	Polarization	Limit dBμV/m	Detector	Result
--	--	Horizontal	--	QP	Pass
--	--	Vertical	--	QP	Pass

## 2462MHz (Above 1GHz)

Frequency MHz	Emission Level dBuV/m	Polarization	Limit dBμV/m	Detector	Result	Corr. (dB)
2378.25*	42.43	Horizontal	74.00	PK	Pass	-5.8
2048.37*	36.89	Vertical	74.00	PK	Pass	-8.4

## Remark:

- (1) Data of measurement within this frequency range shown “-” in the table above means the reading of emissions are attenuated more than 20db below the permissible limits or the field strength is too small to be measured.
- (2) “\*” means the emission(s) appear within the restrict bands shall follow the requirement of section 15.205.
- (3) Above 1GHz: Corrector factor = Antenna Factor + Cable Loss- Amplifier Gain
- (4) Below 1GHz: Corrector factor = Antenna Factor + Cable Loss



802.11nHT40  
2412MHz (30MHz – 1GHz)

Frequency MHz	Emission Level dBuV/m	Polarization	Limit dBuV/m	Detector	Result
--	--	Horizontal	--	QP	Pass
--	--	Vertical	--	QP	Pass

2422MHz (Above 1GHz)

Frequency MHz	Emission Level dBuV/m	Polarization	Limit dBuV/m	Detector	Result	Corr. (dB)
1439.93*	43.70	Horizontal	74.00	PK	Pass	-11.2
1439.93*	39.36	Vertical	74.00	PK	Pass	-11.2

Remark:

- (5) Data of measurement within this frequency range shown “-” in the table above means the reading of emissions are attenuated more than 20db below the permissible limits or the field strength is too small to be measured.
- (6) “\*” means the emission(s) appear within the restrict bands shall follow the requirement of section 15.205.
- (7) Above 1GHz: Corrector factor = Antenna Factor + Cable Loss- Amplifier Gain
- (8) Below 1GHz: Corrector factor = Antenna Factor + Cable Loss

## 2437MHz (30MHz – 1GHz)

Frequency MHz	Emission Level dBuV/m	Polarization	Limit dBµV/m	Detector	Result
--	--	Horizontal	--	QP	Pass
--	--	Vertical	--	QP	Pass

## 2437MHz (Above 1GHz)

Frequency MHz	Emission Level dBuV/m	Polarization	Limit dBµV/m	Detector	Result	Corr. (dB)
1440.06*	34.34	Horizontal	74.00	PK	Pass	-11.2
1440.00*	35.26	Vertical	74.00	PK	Pass	-11.2

## Remark:

- (5) Data of measurement within this frequency range shown “-” in the table above means the reading of emissions are attenuated more than 20db below the permissible limits or the field strength is too small to be measured.
- (6) “\*\*” means the emission(s) appear within the restrict bands shall follow the requirement of section 15.205.
- (7) Above 1GHz: Corrector factor = Antenna Factor + Cable Loss- Amplifier Gain
- (8) Below 1GHz: Corrector factor = Antenna Factor + Cable Loss

## 2452MHz (30MHz – 1GHz)

Frequency MHz	Emission Level dBuV/m	Polarization	Limit dBµV/m	Detector	Result
--	--	Horizontal	--	QP	Pass
--	--	Vertical	--	QP	Pass

## 2452MHz (Above 1GHz)

Frequency MHz	Emission Level dBuV/m	Polarization	Limit dBµV/m	Detector	Result	Corr. (dB)
4905.00*	46.70	Horizontal	74.00	PK	Pass	3.9
4897.50*	46.64	Vertical	74.00	PK	Pass	3.9

## Remark:

- (5) Data of measurement within this frequency range shown “-” in the table above means the reading of emissions are attenuated more than 20db below the permissible limits or the field strength is too small to be measured.
- (6) “\*\*” means the emission(s) appear within the restrict bands shall follow the requirement of section 15.205.
- (7) Above 1GHz: Corrector factor = Antenna Factor + Cable Loss- Amplifier Gain
- (8) Below 1GHz: Corrector factor = Antenna Factor + Cable Loss

## 10 Test Equipment List

### List of Test Instruments

DESCRIPTION	MANUFACTURER	MODEL NO.	SERIAL NO.	CAL. DUE DATE
Signal Analyzer	Rohde & Schwarz	FSV40	101030	2019-7-6
EMI Test Receiver	Rohde & Schwarz	ESR 26	101269	2019-7-6
Trilog Super Broadband Test Antenna	Schwarzbeck	VULB 9163	707	2019-7-6
Horn Antenna	Rohde & Schwarz	HF907	102294	2019-7-6
Pre-amplifier	Rohde & Schwarz	SCU 18	102230	2019-7-6
3m Semi-anechoic chamber	TDK	9X6X6	----	2019-5-29
EMI Test Receiver	Rohde & Schwarz	ESR 26	101269	2019-7-6
Trilog Super Broadband Test Antenna	Schwarzbeck	VULB 9163	707	2019-7-6
Horn Antenna	Rohde & Schwarz	HF907	102294	2019-7-6
EMI Test Receiver	Rohde & Schwarz	ESR 3	101782	2019-7-6
LISN	Rohde & Schwarz	ENV4200	100249	2019-7-6
LISN	Rohde & Schwarz	ENV216	100326	2019-7-6
ISN	Rohde & Schwarz	ENY81	100177	2019-7-6
ISN	Rohde & Schwarz	ENY81-CA6	101664	2019-7-6
High Voltage Probe	Rohde & Schwarz	TK9420(VT94 20)	9420-58	2019-7-6
RF Current Probe	Rohde & Schwarz	EZ-17	100816	2019-7-6

#### C - Conducted RF tests

- Conducted peak output power
- 6dB bandwidth
- Power spectral density\*
- Spurious RF conducted emissions
- Band edge



## 11 System Measurement Uncertainty

For a 95% confidence level, the measurement expanded uncertainties for defined systems, in accordance with the recommendations of ISO 17025 were:

### System Measurement Uncertainty

System Measurement Uncertainty	
Test Items	Extended Uncertainty
Uncertainty for Radiated Spurious Emission 25MHz-3000MHz	Horizontal: 4.98dB; Vertical: 5.06dB;
Uncertainty for Radiated Spurious Emission 3000MHz-18000MHz	Horizontal: 4.95dB; Vertical: 4.94dB;
Uncertainty for Radiated Spurious Emission 18000MHz-40000MHz	Horizontal: 5.14dB; Vertical: 5.12dB;
Uncertainty for Conducted RF test with TS 8997	Power level test involved: 2.06dB Frequency test involved: $1.16 \times 10^{-7}$
Uncertainty for Conducted Emission 150kHz-30MHz (for test using AMN ENV432 or ENV4200)	3.21dB