

FCC Test Report

Report No.: RF200424C06-4

FCC ID: 2ARXKVHE09-4GL

Test Model: VHE09-4GL

Series Model: VHE09XXXXX (X=A-Z, 0-9, blank or "-")

Received Date: Apr. 24, 2020

Test Date: May 27 ~ Jun. 02, 2020

Issued Date: Jun. 11, 2020

Applicant: Veea Inc

Address: 164 E 83rd Street, New York NY, 10028, USA

Issued By: Bureau Veritas Consumer Products Services (H.K.) Ltd., Taoyuan Branch
Lin Kou Laboratories

Lab Address: No. 47-2, 14th Ling, Chia Pau Vil., Lin Kou Dist., New Taipei City, Taiwan

Test Location: No. 19, Hwa Ya 2nd Rd., Wen Hwa Vil., Kwei Shan Dist., Taoyuan City
33383, Taiwan

**FCC Registration /
Designation Number:** 788550 / TW0003



This report is for your exclusive use. Any copying or replication of this report to or for any other person or entity, or use of our name or trademark, is permitted only with our prior written permission. This report sets forth our findings solely with respect to the test samples identified herein. The results set forth in this report are not indicative or representative of the quality or characteristics of the lot from which a test sample was taken or any similar or identical product unless specifically and expressly noted. Our report includes all of the tests requested by you and the results thereof based upon the information that you provided to us. You have 60 days from date of issuance of this report to notify us of any material error or omission caused by our negligence, provided, however, that such notice shall be in writing and shall specifically address the issue you wish to raise. A failure to raise such issue within the prescribed time shall constitute your unqualified acceptance of the completeness of this report, the tests conducted and the correctness of the report contents. Unless specific mention, the uncertainty of measurement has been explicitly taken into account to declare the compliance or non-compliance to the specification.

Table of Contents

Release Control Record	4
1 Certificate of Conformity	5
2 Summary of Test Results	6
2.1 Measurement Uncertainty	6
2.2 Modification Record	6
3 General Information	7
3.1 General Description of EUT	7
3.2 Description of Test Modes	8
3.2.1 Test Mode Applicability and Tested Channel Detail	9
3.3 Duty Cycle of Test Signal	10
3.4 Description of Support Units	11
3.4.1 Configuration of System under Test	11
3.5 General Description of Applied Standards and references	12
4 Test Types and Results	13
4.1 Radiated Emission and Bandedge Measurement.....	13
4.1.1 Limits of Radiated Emission and Bandedge Measurement	13
4.1.2 Test Instruments	14
4.1.3 Test Procedures.....	15
4.1.4 Deviation from Test Standard	15
4.1.5 Test Setup.....	16
4.1.6 EUT Operating Conditions.....	17
4.1.7 Test Results	18
4.2 Conducted Emission Measurement	39
4.2.1 Limits of Conducted Emission Measurement	39
4.2.2 Test Instruments	39
4.2.3 Test Procedures.....	40
4.2.4 Deviation from Test Standard	40
4.2.5 Test Setup.....	40
4.2.6 EUT Operating Condition	40
4.2.7 Test Results	41
4.3 6dB Bandwidth Measurement	45
4.3.1 Limits of 6dB Bandwidth Measurement	45
4.3.2 Test Setup.....	45
4.3.3 Test Instruments	45
4.3.4 Test Procedure	45
4.3.5 Deviation from Test Standard	45
4.3.6 EUT Operating Conditions.....	45
4.3.7 Test Result.....	46
4.4 Conducted Output Power Measurement.....	47
4.4.1 Limits of Conducted Output Power Measurement	47
4.4.2 Test Setup.....	47
4.4.3 Test Instruments	47
4.4.4 Test Procedure	47
4.4.5 Deviation from Test Standard	47
4.4.6 EUT Operating Condition	47
4.4.7 Test Results	48
4.5 Power Spectral Density Measurement.....	49
4.5.1 Limits of Power Spectral Density Measurement.....	49
4.5.2 Test Setup.....	49
4.5.3 Test Instruments	49
4.5.4 Test Procedure	49
4.5.5 Deviation from Test Standard	49

4.5.6 EUT Operating Condition	49
4.5.7 Test Results	50
4.6 Conducted Out of Band Emission Measurement.....	51
4.6.1 Limits of Conducted Out Of Band Emission Measurement.....	51
4.6.2 Test Setup.....	51
4.6.3 Test Instruments	51
4.6.4 Test Procedure	51
4.6.5 Deviation from Test Standard	51
4.6.6 EUT Operating Condition	51
4.6.7 Test Results	51
5 Pictures of Test Arrangements.....	53
Appendix – Information of the Testing Laboratories	54



Release Control Record

Issue No.	Description	Date Issued
RF200424C06-4	Original release	Jun. 11, 2020

1 Certificate of Conformity

Product: veeaHub

Brand: 

Test Model: VHE09-4GL

Series Model: VHE09XXXXX (X=A-Z, 0-9, blank or "-")

Sample Status: Engineering sample

Applicant: Veea Inc

Test Date: May 27 ~ Jun. 02, 2020

Standards: 47 CFR FCC Part 15, Subpart C (Section 15.247)
ANSI C63.10:2013

The above equipment has been tested by **Bureau Veritas Consumer Products Services (H.K.) Ltd., Taoyuan Branch**, and found compliance with the requirement of the above standards. The test record, data evaluation & Equipment Under Test (EUT) configurations represented herein are true and accurate accounts of the measurements of the sample's RF characteristics under the conditions specified in this report.

Prepared by :  , **Date:** Jun. 11, 2020
Polly Chien / Specialist

Approved by :  , **Date:** Jun. 11, 2020
Bruce Chen / Senior Project Engineer

2 Summary of Test Results

47 CFR FCC Part 15, Subpart C (Section 15.247)			
FCC Clause	Test Item	Result	Remarks
15.207	AC Power Conducted Emission	Pass	Meet the requirement of limit. Minimum passing margin is -1.61dB at 0.57154MHz.
15.205 / 15.209 / 15.247(d)	Radiated Emissions and Band Edge Measurement	Pass	Meet the requirement of limit. Minimum passing margin is -1.1dB at 72.00MHz.
15.247(d)	Antenna Port Emission	Pass	Meet the requirement of limit.
15.247(a)(2)	6dB bandwidth	Pass	Meet the requirement of limit.
15.247(b)	Conducted power	Pass	Meet the requirement of limit.
15.247(e)	Power Spectral Density	Pass	Meet the requirement of limit.
15.203	Antenna Requirement	Pass	Antenna connector is N type & SMA a standard connector.

Note: Determining compliance based on the results of the compliance measurement, not taking into account measurement instrumentation uncertainty.

2.1 Measurement Uncertainty

Where relevant, the following measurement uncertainty levels have been estimated for tests performed on the EUT as specified in CISPR 16-4-2:

Measurement	Frequency	Expanded Uncertainty (k=2) (\pm)
Conducted Emissions at mains ports	150kHz ~ 30MHz	2.79 dB
Radiated Emissions up to 1 GHz	9kHz ~ 30MHz	3.04 dB
	30MHz ~ 200MHz	3.86 dB
	200MHz ~ 1000MHz	3.87 dB
Radiated Emissions above 1 GHz	1GHz ~ 18GHz	2.29 dB
	18GHz ~ 40GHz	2.29 dB

2.2 Modification Record

There were no modifications required for compliance.

3 General Information

3.1 General Description of EUT

Product	veeaHub
Brand	
Test Model	VHE09-4GL
Series Model	VHE09XXXXX (X=A-Z, 0-9, blank or "-")
Model Difference	Marketing purposes
Sample Status	Engineering sample
Power Supply Rating	48Vdc (Adapter and PoE)
Modulation Type	CSS
Modulation Technology	DTS
Transfer Rate	DR0~DR4 & DR8~ DR13(500kHz): 980 ~ 219000 bps/s
Operating Frequency	Tx (BW:500kHz) : 923.3 MHz – 927.5 MHz Rx (BW:125kHz) : 902.3 MHz – 914.9 MHz Rx (BW:500kHz) : 923.3 MHz – 927.5 MHz
Number of Channel	Tx (BW:500kHz) : 8 channels Rx (BW:125kHz) : 64 channels Rx (BW:500kHz) : 8 channels
Output Power	299.916 mW
Antenna Type	Refer to Note
Antenna Connector	Refer to Note
Accessory Device	Adapter
Cable Supplied	NA

Note:

1. The EUT uses following adapter and PoE.

Adapter	
Brand	EDAC Power Electronics Co., Ltd.
Model	EA1062SGR-480
Input Power	100-240Vac ~2.5A, 50-60Hz
Output Power	48Vdc / 1.35A
Power Line	1.2m DC cable with one core

PoE (Support unit)	
Model	APOE02-WM
Output Power	48Vdc

2. WLAN, zigbee, Bluetooth and LoRa technology can transmit at same time.

3. The LoRa uses following antenna.

Antenna Type	Model	Connector	Gain(dBi)
Dipole	MFB9155NF	N type	5
Dipole	MFB9153	N type	3
Dipole	ET915NPMR	N type	2.7
Dipole	MPAMB700MSMA	SMA	2

* The maximum antenna gain is chosen for final test.

4. The above Antenna information is declared by manufacturer and for more detailed features description, please refer to the manufacturer's specifications, the laboratory shall not be held responsible.

3.2 Description of Test Modes

Tx (BW:500kHz): 8 channels

Channel	Freq. (MHz)	Channel	Freq. (MHz)	Channel	Freq. (MHz)	Channel	Freq. (MHz)
1	923.3	3	924.5	5	925.7	7	926.9
2	923.9	4	925.1	6	926.3	8	927.5

Note: The channels which were indicated in bold type of the above channel list were selected as representative test channel. Therefore only the data of the test channels were recorded in this report.

Rx (BW:125kHz): 64 channels

Channel	Freq. (MHz)	Channel	Freq. (MHz)	Channel	Freq. (MHz)	Channel	Freq. (MHz)
1	902.3	17	905.5	33	908.7	49	911.9
2	902.5	18	905.7	34	908.9	50	912.1
3	902.7	19	905.9	35	909.1	51	912.3
4	902.9	20	906.1	36	909.3	52	912.5
5	903.1	21	906.3	37	909.5	53	912.7
6	903.3	22	906.5	38	909.7	54	912.9
7	903.5	23	906.7	39	909.9	55	913.1
8	903.7	24	906.9	40	910.1	56	913.3
9	903.9	25	907.1	41	910.3	57	913.5
10	904.1	26	907.3	42	910.5	58	913.7
11	904.3	27	907.5	43	910.7	59	913.9
12	904.5	28	907.7	44	910.9	60	914.1
13	904.7	29	907.9	45	911.1	61	914.3
14	904.9	30	908.1	46	911.3	62	914.5
15	905.1	31	908.3	47	911.5	63	914.7
16	905.3	32	908.5	48	911.7	64	914.9

RX (BW:500kHz): 8 channels

Channel	Freq. (MHz)	Channel	Freq. (MHz)	Channel	Freq. (MHz)	Channel	Freq. (MHz)
1	903.3	3	906.2	5	909.4	7	912.6
2	904.6	4	907.8	6	911.0	8	914.2

3.2.1 Test Mode Applicability and Tested Channel Detail

EUT Configure Mode	Applicable to				Description
	RE \geq 1G	RE<1G	PLC	APCM	
A	√	√	√	√	Power from adapter
B	-	√	√	-	Power from PoE

Where RE \geq 1G: Radiated Emission above 1GHz & Bandedge Measurement
 RE<1G: Radiated Emission below 1GHz
 PLC: Power Line Conducted Emission
 APCM: Antenna Port Conducted Measurement

Note:

1. The EUT had been pre-tested on the positioned of each 3 axis and modulation type. The worst case was found when positioned on Z-plane.
2. "-" means no effect.

Radiated Emission Test (Above 1GHz):

- Pre-Scan has been conducted to determine the worst-case mode from all possible combinations between available modulations, data rates and antenna ports (if EUT with antenna diversity architecture).
- Following channel(s) was (were) selected for the final test as listed below.

EUT Configure Mode	Available Channel	Tested Channel	Modulation Type
A	1 to 8	1, 4, 8	CCS

Radiated Emission Test (Below 1GHz):

- Pre-Scan has been conducted to determine the worst-case mode from all possible combinations between available modulations, data rates and antenna ports (if EUT with antenna diversity architecture).
- Following channel(s) was (were) selected for the final test as listed below.

EUT Configure Mode	Available Channel	Tested Channel	Modulation Type
A, B	1 to 8	1, 4, 8	CCS

Power Line Conducted Emission Test:

- Pre-Scan has been conducted to determine the worst-case mode from all possible combinations between available modulations, data rates and antenna ports (if EUT with antenna diversity architecture).
- Following channel(s) was (were) selected for the final test as listed below.

EUT Configure Mode	Available Channel	Tested Channel	Modulation Type
A, B	1 to 8	1	CCS

Antenna Port Conducted Measurement:

- This item includes all test value of each mode, but only includes spectrum plot of worst value of each mode.
- Pre-Scan has been conducted to determine the worst-case mode from all possible combinations between available modulations, data rates and antenna ports (if EUT with antenna diversity architecture).
- Following channel(s) was (were) selected for the final test as listed below.

EUT Configure Mode	Available Channel	Tested Channel	Modulation Type
A	1 to 8	1, 4, 8	CCS

Test Condition:

Applicable to	Environmental Conditions	Input Power (system)	Tested by
RE \geq 1G	23 deg. C, 67% RH	120Vac, 60Hz	Adair Peng
RE<1G	25 deg. C, 65% RH	120Vac, 60Hz 48Vdc	Greg Lin
PLC	25 deg. C, 69% RH	120Vac, 60Hz 48Vdc	Jones Chang
APCM	25 deg. C, 60% RH	120Vac, 60Hz	Ted Chang

3.3 Duty Cycle of Test Signal

Duty cycle of test signal is 100 %, duty factor is not required.

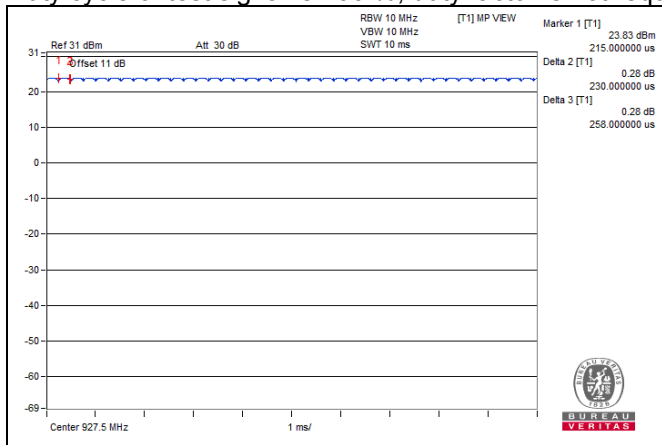

3.4 Description of Support Units

The EUT has been tested as an independent unit together with other necessary accessories or support units. The following support units or accessories were used to form a representative test configuration during the tests.

ID	Product	Brand	Model No.	Serial No.	FCC ID	Remarks
A.	Load	NA	NA	NA	NA	-
B.	USB Flash	HP	v250W	04	NA	-
C.	USB Flash	HP	v250W	05	NA	-
D.	USB Flash	HP	v250W	09	NA	-
E.	PoE	NA	APOE02-WM	NA	NA	Provided by manufacturer

Note: All power cords of the above support units are non-shielded (1.8m).

ID	Cable Descriptions	Qty.	Length (m)	Shielding (Yes/No)	Cores (Qty.)	Remarks
1.	LAN cable	2	1.5	N	0	RJ45, Cat5e
2.	LAN cable	1	1.5	N	0	RJ45, Cat5e
3.	Console cable	1	2	N	0	-
4.	LAN cable	1	1.5	N	0	RJ45, Cat5e
5.	LAN cable	1	1.5	N	0	RJ45, Cat5e

3.4.1 Configuration of System under Test

Test Mode A

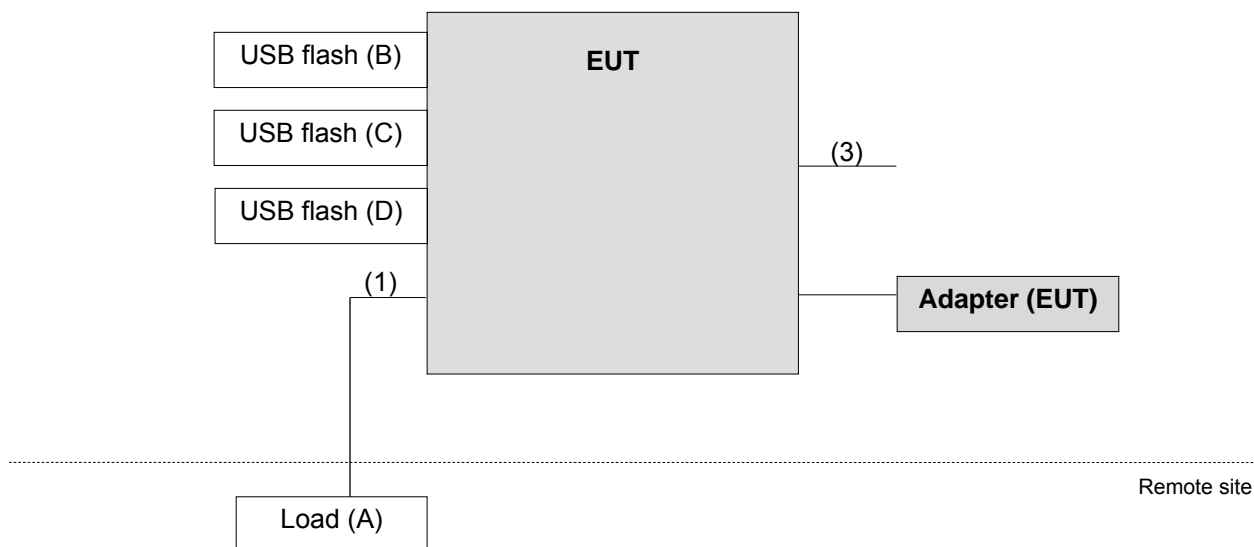

Test Mode B

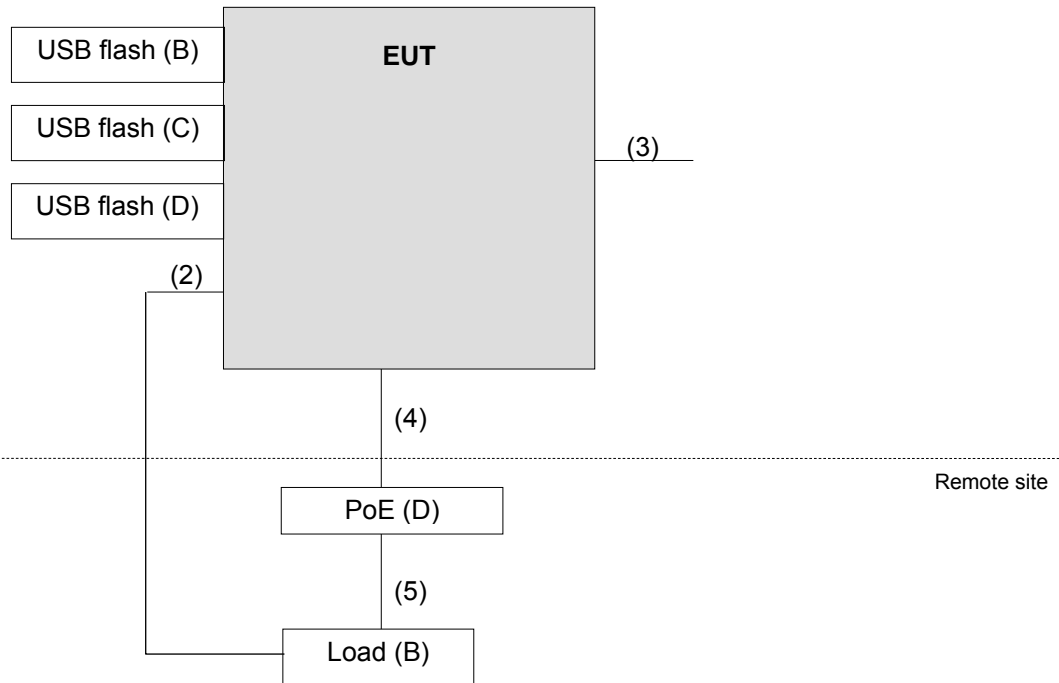

3.5 General Description of Applied Standards and references

The EUT is a RF Product. According to the specifications of the manufacturer, it must comply with the requirements of the following standards and references:

FCC Part 15, Subpart C (15.247)

ANSI C63.10:2013

All test items have been performed and recorded as per the above standards.

References Test Guidance:

KDB 558074 D01 15.247 Meas Guidance v05r02

All test items have been performed as a reference to the above KDB test guidance.

4 Test Types and Results

4.1 Radiated Emission and Bandedge Measurement

4.1.1 Limits of Radiated Emission and Bandedge Measurement

Radiated emissions which fall in the restricted bands must comply with the radiated emission limits specified as below table. Other emissions shall be at least 20dB below the highest level of the desired power:

Frequencies (MHz)	Field Strength (microvolts/meter)	Measurement Distance (meters)
0.009 ~ 0.490	2400/F(kHz)	300
0.490 ~ 1.705	24000/F(kHz)	30
1.705 ~ 30.0	30	30
30 ~ 88	100	3
88 ~ 216	150	3
216 ~ 960	200	3
Above 960	500	3

Note:

1. The lower limit shall apply at the transition frequencies.
2. Emission level (dBuV/m) = 20 log Emission level (uV/m).
3. For frequencies above 1000MHz, the field strength limits are based on average detector, however, the peak field strength of any emission shall not exceed the maximum permitted average limits, specified above by more than 20dB under any condition of modulation.

4.1.2 Test Instruments

Description & Manufacturer	Model No.	Serial No.	Cal. Date	Cal. Due
Test Receiver ROHDE & SCHWARZ	ESCI	100424	Dec. 31, 2019	Dec. 30, 2020
Spectrum Analyzer ROHDE & SCHWARZ	FSP40	100269	Jun. 10, 2019	Jun. 09, 2020
			Jun. 09, 2020	Jun. 08, 2021
Spectrum Analyzer ROHDE & SCHWARZ	FSV40	100980	Apr. 20, 2020	Apr. 19, 2021
BILOG Antenna SCHWARZBECK	VULB9168	9168-171	Nov. 11, 2019	Nov. 10, 2020
HORN Antenna SCHWARZBECK	9120D	209	Nov. 24, 2019	Nov. 23, 2020
HORN Antenna SCHWARZBECK	BBHA 9170	BBHA9170241	Nov. 24, 2019	Nov. 23, 2020
Loop Antenna TESEQ	HLA 6121	45745	Jul. 01, 2019	Jun. 30, 2020
Preamplifier Agilent (Below 1GHz)	8447D	2944A10738	Aug. 20, 2019	Aug. 19, 2020
Preamplifier KEYSIGHT (Above 1GHz)	8449B	3008A01976	Aug. 20, 2019	Aug. 19, 2020
RF Coaxial Cable WOKEN With 5dB PAD	8D-FB	Cable-CH3-01	Aug. 20, 2019	Aug. 19, 2020
RF signal cable HUBER+SUHNER	SUCOFLEX 104	Cable-CH3-03 (223653/4)	Aug. 20, 2019	Aug. 19, 2020
RF signal cable HUBER+SUHNER& EMCI	SUCOFLEX 104&EMC104-SM-S M-8000	Cable-CH3-03 (309224+170907)	Aug. 20, 2019	Aug. 19, 2020
Software BV ADT	ADT_Radiated_ V7.6.15.9.5	NA	NA	NA
Antenna Tower inn-co GmbH	MA 4000	013303	NA	NA
Antenna Tower Controller BV ADT	AT100	AT93021702	NA	NA
Turn Table BV ADT	TT100	TT93021702	NA	NA
Turn Table Controller BV ADT	SC100	SC93021702	NA	NA
Boresight Antenna Fixture	FBA-01	FBA-SIP01	NA	NA
USB Wideband Power Sensor KEYSIGHT	U2021XA	MY55050005/MY5519 0004/MY55190007/MY 55210005	Jul. 15, 2019	Jul. 14, 2020

Note: 1. The calibration interval of the above test instruments is 12 months and the calibrations are traceable to NML/ROC and NIST/USA.
2. The test was performed in HwaYa Chamber 3.

4.1.3 Test Procedures

For Radiated emission below 30MHz

- a. The EUT was placed on the top of a rotating table 0.8 meters above the ground at a 3 meter chamber room. The table was rotated 360 degrees to determine the position of the highest radiation.
- b. The EUT was set 3 meters away from the interference-receiving antenna, which was mounted on the top of a variable-height antenna tower.
- c. Parallel, perpendicular, and ground-parallel orientations of the antenna are set to make the measurement.
- d. For each suspected emission, the EUT was arranged to its worst case and the rotatable table was turned from 0 degrees to 360 degrees to find the maximum reading.
- e. The test-receiver system was set to Quasi-Peak Detect Function and Specified Bandwidth with Maximum Hold Mode.

Note:

1. The resolution bandwidth and video bandwidth of test receiver/spectrum analyzer is 9kHz at frequency below 30MHz.

For Radiated emission above 30MHz

- a. The EUT was placed on the top of a rotating table 0.8 meters (for 30MHz ~ 1GHz) / 1.5 meters (for above 1GHz) above the ground at 3 meter chamber room for test. The table was rotated 360 degrees to determine the position of the highest radiation.
- b. The EUT was set 3 meters away from the interference-receiving antenna, which was mounted on the top of a variable-height antenna tower.
- c. The height of antenna is varied from one meter to four meters above the ground to determine the maximum value of the field strength. Both horizontal and vertical polarizations of the antenna are set to make the measurement.
- d. For each suspected emission, the EUT was arranged to its worst case and then the antenna was tuned to heights from 1 meter to 4 meters and the rotatable table was turned from 0 degrees to 360 degrees to find the maximum reading.
- e. The test-receiver system was set to quasi-peak detect function and specified bandwidth with maximum hold mode when the test frequency is below 1 GHz.
- f. The test-receiver system was set to peak and average detect function and specified bandwidth with maximum hold mode when the test frequency is above 1 GHz. If the peak reading value also meets average limit, measurement with the average detector is unnecessary.

Note:

1. The resolution bandwidth and video bandwidth of test receiver/spectrum analyzer is 120kHz for Quasi-peak detection (QP) at frequency below 1GHz.
2. The resolution bandwidth of test receiver/spectrum analyzer is 1 MHz and the video bandwidth is 3 MHz for Peak detection (PK) at frequency above 1GHz.
3. The resolution bandwidth of test receiver/spectrum analyzer is 1MHz and the video bandwidth is $\geq 1/T$ (Duty cycle < 98%) or 10Hz (Duty cycle $\geq 98\%$) for Average detection (AV) at frequency above 1GHz.
4. All modes of operation were investigated and the worst-case emissions are reported.

4.1.4 Deviation from Test Standard

No deviation.

4.1.5 Test Setup

For Radiated emission below 30MHz

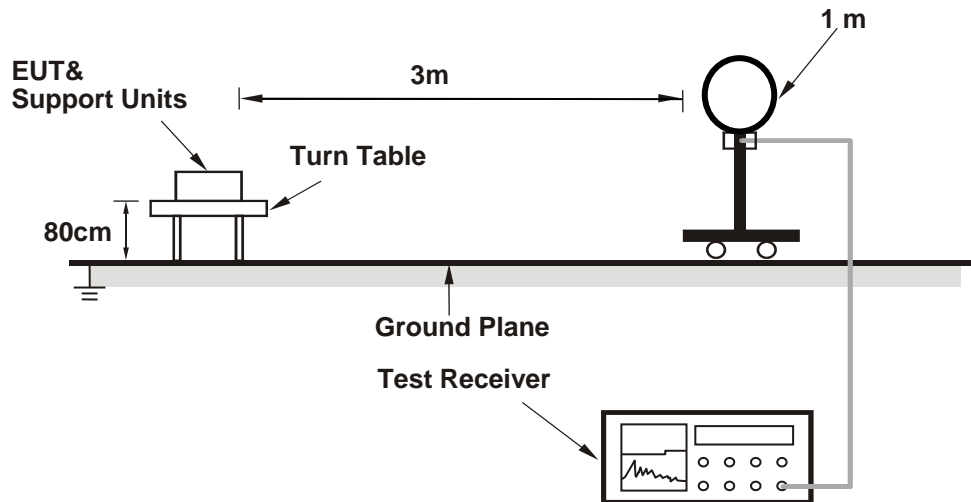

For Radiated emission 30MHz to 1GHz

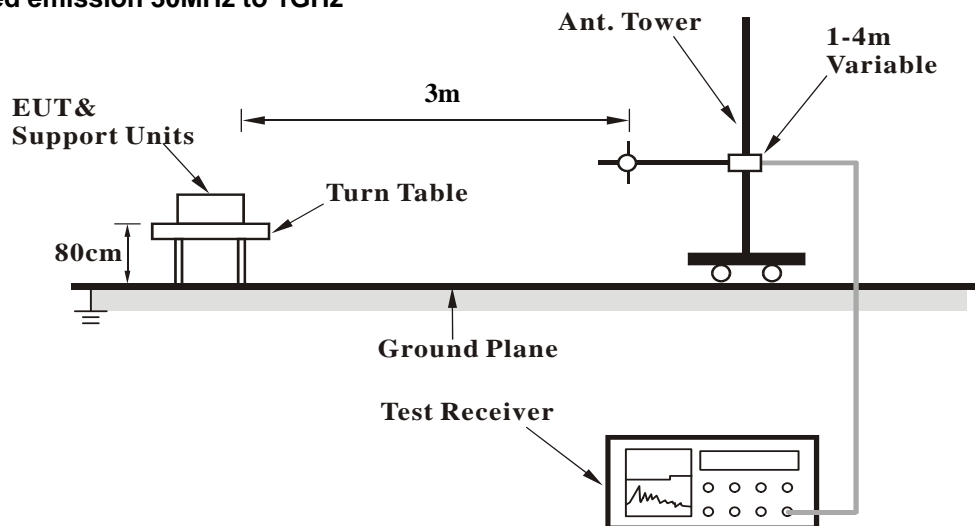

For Radiated emission above 1GHz

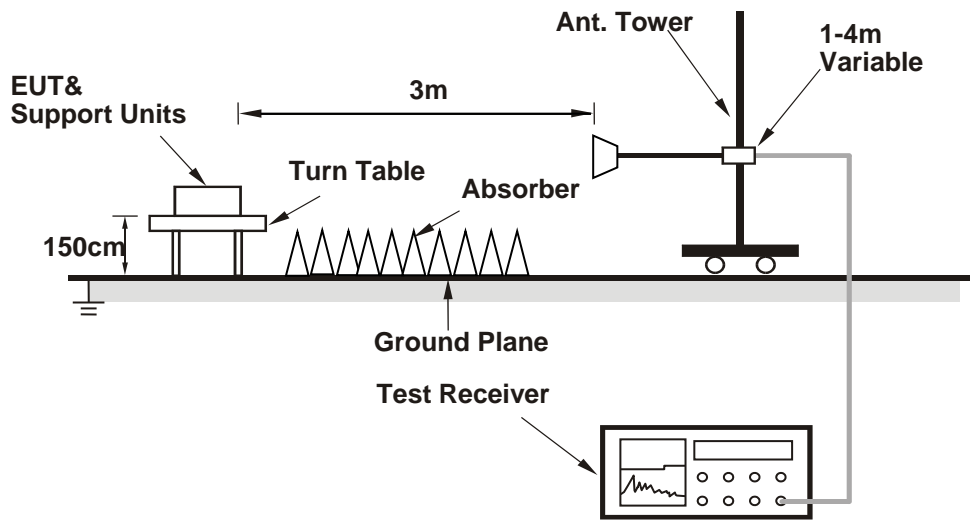

For the actual test configuration, please refer to the attached file (Test Setup Photo).

4.1.6 EUT Operating Conditions

- a. Set the EUT under transmission condition continuously at specific channel frequency.

4.1.7 Test Results

CHANNEL	TX Channel 1	DETECTOR FUNCTION	Quasi-Peak (QP)
FREQUENCY RANGE	902MHz ~ 928MHz		

ANTENNA POLARITY & TEST DISTANCE: HORIZONTAL AT 3 M								
NO.	FREQ. (MHz)	EMISSION LEVEL (dBuV/m)	LIMIT (dBuV/m)	MARGIN (dB)	ANTENNA HEIGHT (m)	TABLE ANGLE (Degree)	RAW VALUE (dBuV)	CORRECTION FACTOR (dB/m)
1	902.00	43.6 QP	91.4	-47.8	1.01 H	328	10.3	33.3
2	*923.30	111.4 QP			1.01 H	328	77.7	33.7

Remarks:

1. Emission Level(dBuV/m) = Raw Value(dBuV) + Correction Factor(dB/m).
2. Correction Factor(dB/m) = Antenna Factor(dB/m) + Cable Factor(dB) – Pre-Amplifier Factor(dB).
3. The other emission levels were very low against the limit.
4. Margin value = Emission Level – Limit value.
5. " * ": Fundamental frequency.

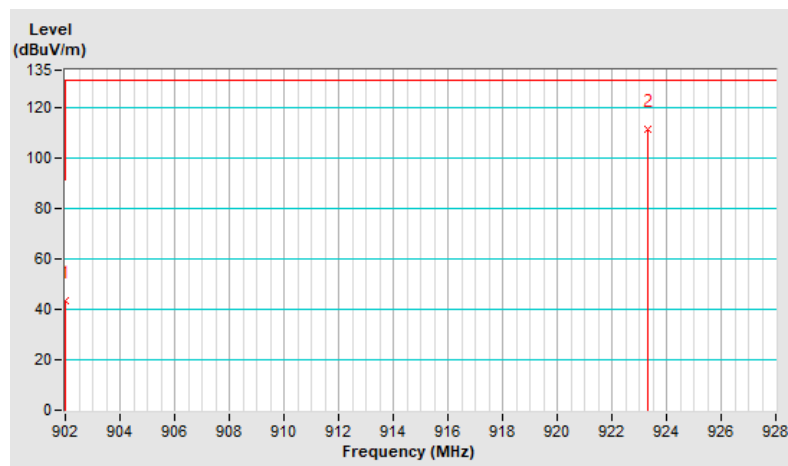

CHANNEL	TX Channel 1	DETECTOR FUNCTION	Quasi-Peak (QP)
FREQUENCY RANGE	902MHz ~ 928MHz		

ANTENNA POLARITY & TEST DISTANCE: VERTICAL AT 3 M								
NO.	FREQ. (MHz)	EMISSION LEVEL (dBuV/m)	LIMIT (dBuV/m)	MARGIN (dB)	ANTENNA HEIGHT (m)	TABLE ANGLE (Degree)	RAW VALUE (dBuV)	CORRECTION FACTOR (dB/m)
1	902.00	45.8 QP	109.7	-63.9	1.45 V	339	12.5	33.3
2	*923.30	129.7 QP			1.45 V	339	96.0	33.7

Remarks:

1. Emission Level(dBuV/m) = Raw Value(dBuV) + Correction Factor(dB/m).
2. Correction Factor(dB/m) = Antenna Factor(dB/m) + Cable Factor(dB) – Pre-Amplifier Factor(dB).
3. The other emission levels were very low against the limit.
4. Margin value = Emission Level – Limit value.
5. " * " : Fundamental frequency.

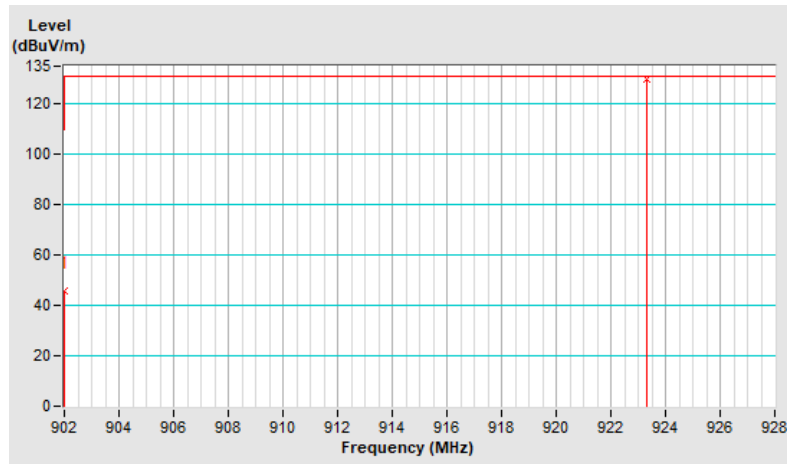

CHANNEL	TX Channel 4	DETECTOR FUNCTION	Quasi-Peak (QP)
FREQUENCY RANGE	902MHz ~ 928MHz		

ANTENNA POLARITY & TEST DISTANCE: HORIZONTAL AT 3 M								
NO.	FREQ. (MHz)	EMISSION LEVEL (dBuV/m)	LIMIT (dBuV/m)	MARGIN (dB)	ANTENNA HEIGHT (m)	TABLE ANGLE (Degree)	RAW VALUE (dBuV)	CORRECTION FACTOR (dB/m)
1	*925.10	111.3 QP			1.07 H	333	77.5	33.8

Remarks:

1. Emission Level(dBuV/m) = Raw Value(dBuV) + Correction Factor(dB/m).
2. Correction Factor(dB/m) = Antenna Factor(dB/m) + Cable Factor(dB) – Pre-Amplifier Factor(dB).
3. The other emission levels were very low against the limit.
4. Margin value = Emission Level – Limit value.
5. " * " : Fundamental frequency.

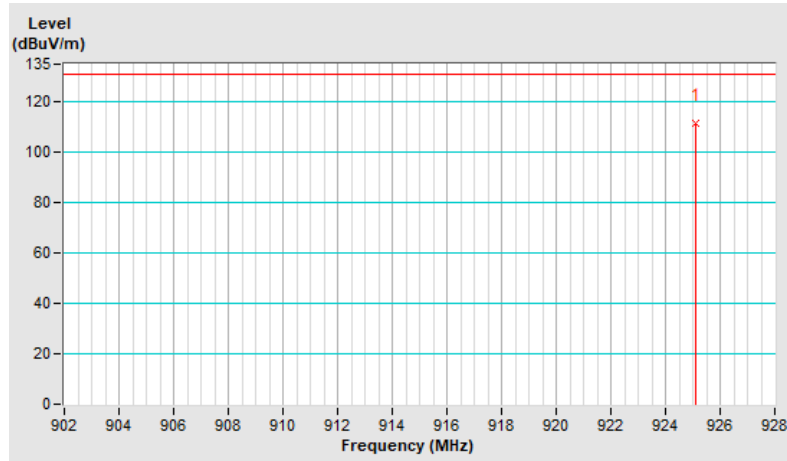

CHANNEL	TX Channel 4	DETECTOR FUNCTION	Quasi-Peak (QP)
FREQUENCY RANGE	902MHz ~ 928MHz		

ANTENNA POLARITY & TEST DISTANCE: VERTICAL AT 3 M								
NO.	FREQ. (MHz)	EMISSION LEVEL (dBuV/m)	LIMIT (dBuV/m)	MARGIN (dB)	ANTENNA HEIGHT (m)	TABLE ANGLE (Degree)	RAW VALUE (dBuV)	CORRECTION FACTOR (dB/m)
1	*925.10	129.4 QP			1.50 V	344	95.6	33.8

Remarks:

1. Emission Level(dBuV/m) = Raw Value(dBuV) + Correction Factor(dB/m).
2. Correction Factor(dB/m) = Antenna Factor(dB/m) + Cable Factor(dB) – Pre-Amplifier Factor(dB).
3. The other emission levels were very low against the limit.
4. Margin value = Emission Level – Limit value.
5. " * " : Fundamental frequency.

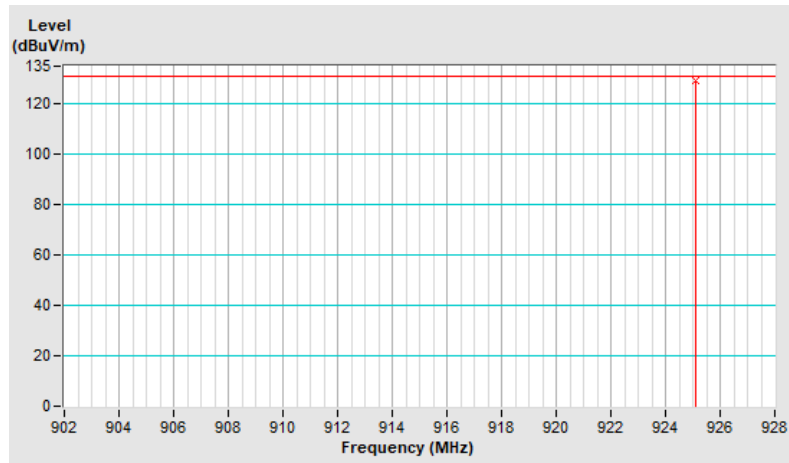

CHANNEL	TX Channel 8	DETECTOR FUNCTION	Quasi-Peak (QP)
FREQUENCY RANGE	902MHz ~ 928MHz		

ANTENNA POLARITY & TEST DISTANCE: HORIZONTAL AT 3 M								
NO.	FREQ. (MHz)	EMISSION LEVEL (dBuV/m)	LIMIT (dBuV/m)	MARGIN (dB)	ANTENNA HEIGHT (m)	TABLE ANGLE (Degree)	RAW VALUE (dBuV)	CORRECTION FACTOR (dB/m)
1	*927.50	111.4 QP			1.00 H	330	77.6	33.8
2	928.00	74.5 QP	91.4	-16.9	1.00 H	330	40.6	33.9

Remarks:

1. Emission Level(dBuV/m) = Raw Value(dBuV) + Correction Factor(dB/m).
2. Correction Factor(dB/m) = Antenna Factor(dB/m) + Cable Factor(dB) – Pre-Amplifier Factor(dB).
3. The other emission levels were very low against the limit.
4. Margin value = Emission Level – Limit value.
5. " * " : Fundamental frequency.

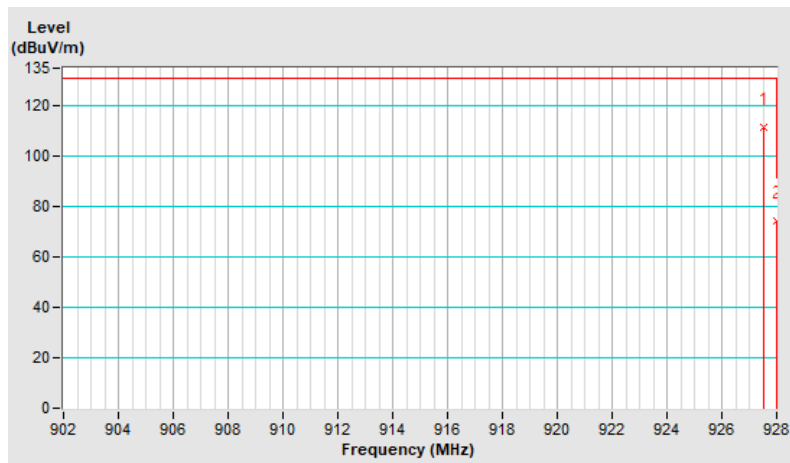

CHANNEL	TX Channel 8	DETECTOR FUNCTION	Quasi-Peak (QP)
FREQUENCY RANGE	902MHz ~ 928MHz		

ANTENNA POLARITY & TEST DISTANCE: VERTICAL AT 3 M								
NO.	FREQ. (MHz)	EMISSION LEVEL (dBuV/m)	LIMIT (dBuV/m)	MARGIN (dB)	ANTENNA HEIGHT (m)	TABLE ANGLE (Degree)	RAW VALUE (dBuV)	CORRECTION FACTOR (dB/m)
1	*927.50	129.0 QP			1.47 V	337	95.2	33.8
2	928.00	93.3 QP	109.0	-15.7	1.47 V	337	59.4	33.9

Remarks:

1. Emission Level(dBuV/m) = Raw Value(dBuV) + Correction Factor(dB/m).
2. Correction Factor(dB/m) = Antenna Factor(dB/m) + Cable Factor(dB) – Pre-Amplifier Factor(dB).
3. The other emission levels were very low against the limit.
4. Margin value = Emission Level – Limit value.
5. " * " : Fundamental frequency.

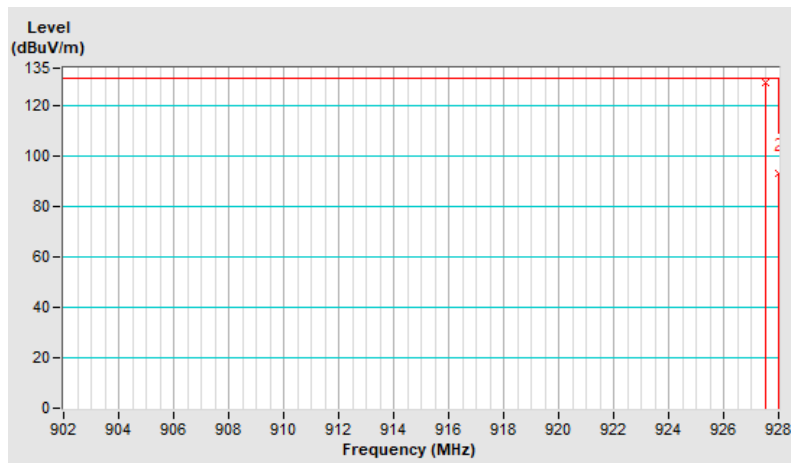

Above 1GHz Data:

CHANNEL	TX Channel 1	DETECTOR FUNCTION	Peak (PK)
FREQUENCY RANGE	1GHz ~10GHz		Average (AV)

ANTENNA POLARITY & TEST DISTANCE: HORIZONTAL AT 3 M

NO.	FREQ. (MHz)	EMISSION LEVEL (dBuV/m)	LIMIT (dBuV/m)	MARGIN (dB)	ANTENNA HEIGHT (m)	TABLE ANGLE (Degree)	RAW VALUE (dBuV)	CORRECTION FACTOR (dB/m)
1	4616.50	45.3 PK	74.0	-28.7	1.70 H	243	42.9	2.4
2	4616.50	33.2 AV	54.0	-20.8	1.70 H	243	30.8	2.4
3	8309.70	59.7 PK	74.0	-14.3	1.88 H	255	48.0	11.7
4	8309.70	46.7 AV	54.0	-7.3	1.88 H	255	35.0	11.7

ANTENNA POLARITY & TEST DISTANCE: VERTICAL AT 3 M

NO.	FREQ. (MHz)	EMISSION LEVEL (dBuV/m)	LIMIT (dBuV/m)	MARGIN (dB)	ANTENNA HEIGHT (m)	TABLE ANGLE (Degree)	RAW VALUE (dBuV)	CORRECTION FACTOR (dB/m)
1	4616.50	47.7 PK	74.0	-26.3	2.27 V	134	45.3	2.4
2	4616.50	36.0 AV	54.0	-18.0	2.27 V	134	33.6	2.4
3	8309.70	63.2 PK	74.0	-10.8	2.01 V	250	51.5	11.7
4	8309.70	48.7 AV	54.0	-5.3	2.01 V	250	37.0	11.7

Remarks:

1. Emission Level(dBuV/m) = Raw Value(dBuV) + Correction Factor(dB/m).
2. Correction Factor(dB/m) = Antenna Factor(dB/m) + Cable Factor(dB) – Pre-Amplifier Factor(dB).
3. The other emission levels were very low against the limit.
4. Margin value = Emission Level – Limit value.
5. The EUT was tested by a test tool (provided by manufacturer), please refer to section 3.3 for duty cycle spectrum plot.

CHANNEL	TX Channel 4	DETECTOR FUNCTION	Peak (PK)
FREQUENCY RANGE	1GHz ~10GHz		Average (AV)

ANTENNA POLARITY & TEST DISTANCE: HORIZONTAL AT 3 M

NO.	FREQ. (MHz)	EMISSION LEVEL (dBuV/m)	LIMIT (dBuV/m)	MARGIN (dB)	ANTENNA HEIGHT (m)	TABLE ANGLE (Degree)	RAW VALUE (dBuV)	CORRECTION FACTOR (dB/m)
1	4625.50	45.5 PK	74.0	-28.5	1.81 H	255	43.0	2.5
2	4625.50	33.6 AV	54.0	-20.4	1.81 H	255	31.1	2.5
3	8325.90	56.9 PK	74.0	-17.1	1.91 H	261	45.3	11.6
4	8325.90	43.4 AV	54.0	-10.6	1.91 H	261	31.8	11.6

ANTENNA POLARITY & TEST DISTANCE: VERTICAL AT 3 M

NO.	FREQ. (MHz)	EMISSION LEVEL (dBuV/m)	LIMIT (dBuV/m)	MARGIN (dB)	ANTENNA HEIGHT (m)	TABLE ANGLE (Degree)	RAW VALUE (dBuV)	CORRECTION FACTOR (dB/m)
1	4625.50	48.4 PK	74.0	-25.6	2.06 V	137	45.9	2.5
2	4625.50	37.0 AV	54.0	-17.0	2.06 V	137	34.5	2.5
3	8325.90	58.9 PK	74.0	-15.1	2.00 V	266	47.3	11.6
4	8325.90	45.4 AV	54.0	-8.6	2.00 V	266	33.8	11.6

Remarks:

1. Emission Level(dBuV/m) = Raw Value(dBuV) + Correction Factor(dB/m).
2. Correction Factor(dB/m) = Antenna Factor(dB/m) + Cable Factor(dB) – Pre-Amplifier Factor(dB).
3. The other emission levels were very low against the limit.
4. Margin value = Emission Level – Limit value.
5. The EUT was tested by a test tool (provided by manufacturer), please refer to section 3.3 for duty cycle spectrum plot.

CHANNEL	TX Channel 8	DETECTOR FUNCTION	Peak (PK) Average (AV)
FREQUENCY RANGE	1GHz ~10GHz		

ANTENNA POLARITY & TEST DISTANCE: HORIZONTAL AT 3 M								
NO.	FREQ. (MHz)	EMISSION LEVEL (dBuV/m)	LIMIT (dBuV/m)	MARGIN (dB)	ANTENNA HEIGHT (m)	TABLE ANGLE (Degree)	RAW VALUE (dBuV)	CORRECTION FACTOR (dB/m)
1	4637.50	47.4 PK	74.0	-26.6	2.56 H	120	44.9	2.5
2	4637.50	35.2 AV	54.0	-18.8	2.56 H	120	32.7	2.5
3	8347.50	56.1 PK	74.0	-17.9	2.28 H	93	44.5	11.6
4	8347.50	42.6 AV	54.0	-11.4	2.28 H	93	31.0	11.6

ANTENNA POLARITY & TEST DISTANCE: VERTICAL AT 3 M								
NO.	FREQ. (MHz)	EMISSION LEVEL (dBuV/m)	LIMIT (dBuV/m)	MARGIN (dB)	ANTENNA HEIGHT (m)	TABLE ANGLE (Degree)	RAW VALUE (dBuV)	CORRECTION FACTOR (dB/m)
1	4637.50	48.6 PK	74.0	-25.4	1.96 V	139	46.1	2.5
2	4637.50	37.0 AV	54.0	-17.0	1.96 V	139	34.5	2.5
3	8347.50	60.3 PK	74.0	-13.7	1.93 V	264	48.7	11.6
4	8347.50	46.2 AV	54.0	-7.8	1.93 V	264	34.6	11.6

Remarks:

1. Emission Level(dBuV/m) = Raw Value(dBuV) + Correction Factor(dB/m).
2. Correction Factor(dB/m) = Antenna Factor(dB/m) + Cable Factor(dB) – Pre-Amplifier Factor(dB).
3. The other emission levels were very low against the limit.
4. Margin value = Emission Level – Limit value.
5. The EUT was tested by a test tool (provided by manufacturer), please refer to section 3.3 for duty cycle spectrum plot.

Below 1GHz Data:

CHANNEL	TX Channel 1	DETECTOR FUNCTION	Quasi-Peak (QP)
FREQUENCY RANGE	9kHz ~ 1GHz	TEST MODE	A

ANTENNA POLARITY & TEST DISTANCE: HORIZONTAL AT 3 M								
NO.	FREQ. (MHz)	EMISSION LEVEL (dBuV/m)	LIMIT (dBuV/m)	MARGIN (dB)	ANTENNA HEIGHT (m)	TABLE ANGLE (Degree)	RAW VALUE (dBuV)	CORRECTION FACTOR (dB/m)
1	96.07	33.2 QP	43.5	-10.3	2.00 H	226	46.9	-13.7
2	167.77	39.2 QP	43.5	-4.3	1.49 H	240	47.9	-8.7
3	239.46	40.0 QP	46.0	-6.0	1.00 H	231	49.9	-9.9
4	335.06	37.3 QP	46.0	-8.7	1.00 H	222	43.6	-6.3
5	426.43	40.0 QP	46.0	-6.0	2.00 H	166	43.4	-3.4
6	499.54	41.4 QP	46.0	-4.6	2.00 H	210	42.9	-1.5

Remarks:

1. Emission Level(dBuV/m) = Raw Value(dBuV) + Correction Factor(dB/m).
2. Correction Factor(dB/m) = Antenna Factor(dB/m) + Cable Factor(dB) – Pre-Amplifier Factor(dB).
3. The other emission levels were very low against the limit.
4. Margin value = Emission Level – Limit value.
5. The emission levels were very low against the limit of frequency range 9kHz ~ 30MHz :the amplitude of spurious emissions attenuated more than 20 dB below the permissible value to be report.

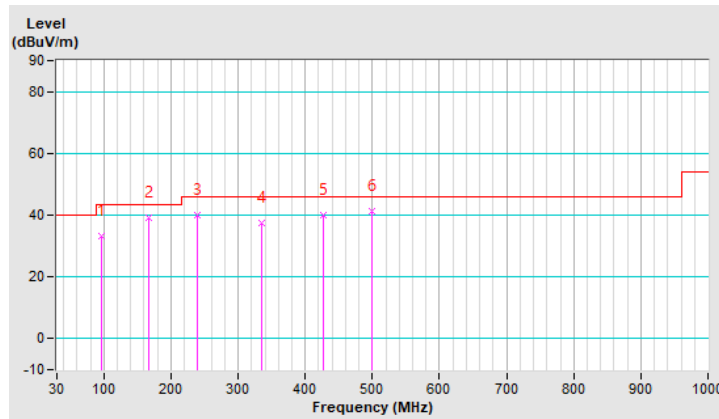

CHANNEL	TX Channel 1	DETECTOR FUNCTION	Quasi-Peak (QP)
FREQUENCY RANGE	9kHz ~ 1GHz	TEST MODE	A

ANTENNA POLARITY & TEST DISTANCE: VERTICAL AT 3 M								
NO.	FREQ. (MHz)	EMISSION LEVEL (dBuV/m)	LIMIT (dBuV/m)	MARGIN (dB)	ANTENNA HEIGHT (m)	TABLE ANGLE (Degree)	RAW VALUE (dBuV)	CORRECTION FACTOR (dB/m)
1	60.00	30.6 QP	40.0	-9.4	1.00 V	60	40.0	-9.4
2	96.07	41.1 QP	43.5	-2.4	1.00 V	161	54.8	-13.7
3	119.97	38.7 QP	43.5	-4.8	1.00 V	56	49.6	-10.9
4	387.07	42.0 QP	46.0	-4.0	1.49 V	46	46.9	-4.9
5	429.25	40.5 QP	46.0	-5.5	1.00 V	192	43.8	-3.3
6	499.54	42.9 QP	46.0	-3.1	1.00 V	193	44.4	-1.5

Remarks:

1. Emission Level(dBuV/m) = Raw Value(dBuV) + Correction Factor(dB/m).
2. Correction Factor(dB/m) = Antenna Factor(dB/m) + Cable Factor(dB) – Pre-Amplifier Factor(dB).
3. The other emission levels were very low against the limit.
4. Margin value = Emission Level – Limit value.
5. The emission levels were very low against the limit of frequency range 9kHz ~ 30MHz :the amplitude of spurious emissions attenuated more than 20 dB below the permissible value to be report.

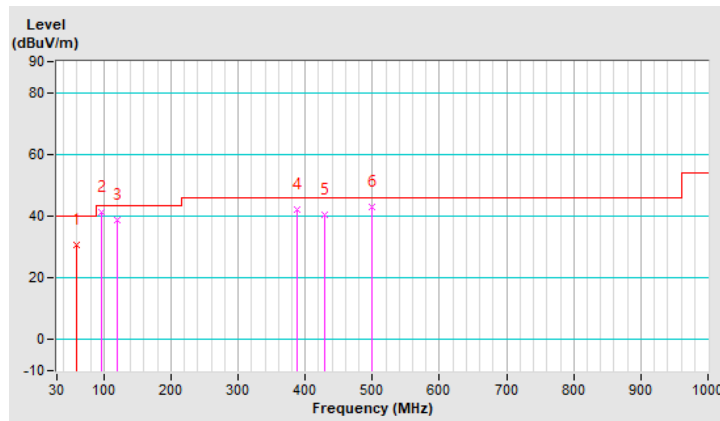

CHANNEL	TX Channel 4	DETECTOR FUNCTION	Quasi-Peak (QP)
FREQUENCY RANGE	9kHz ~ 1GHz	TEST MODE	A

ANTENNA POLARITY & TEST DISTANCE: HORIZONTAL AT 3 M								
NO.	FREQ. (MHz)	EMISSION LEVEL (dBuV/m)	LIMIT (dBuV/m)	MARGIN (dB)	ANTENNA HEIGHT (m)	TABLE ANGLE (Degree)	RAW VALUE (dBuV)	CORRECTION FACTOR (dB/m)
1	96.07	32.2 QP	43.5	-11.3	2.00 H	217	45.9	-13.7
2	167.77	36.8 QP	43.5	-6.7	1.49 H	232	45.5	-8.7
3	191.67	38.0 QP	43.5	-5.5	1.49 H	232	49.3	-11.3
4	384.26	38.9 QP	46.0	-7.1	1.00 H	300	43.8	-4.9
5	427.84	40.3 QP	46.0	-5.7	2.00 H	172	43.6	-3.3
6	499.54	42.4 QP	46.0	-3.6	2.00 H	213	43.9	-1.5

Remarks:

1. Emission Level(dBuV/m) = Raw Value(dBuV) + Correction Factor(dB/m).
2. Correction Factor(dB/m) = Antenna Factor(dB/m) + Cable Factor(dB) – Pre-Amplifier Factor(dB).
3. The other emission levels were very low against the limit.
4. Margin value = Emission Level – Limit value.
5. The emission levels were very low against the limit of frequency range 9kHz ~ 30MHz :the amplitude of spurious emissions attenuated more than 20 dB below the permissible value to be report.

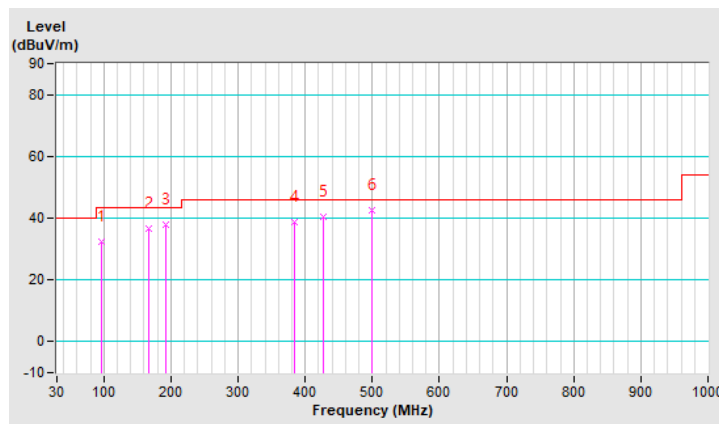

CHANNEL	TX Channel 4	DETECTOR FUNCTION	Quasi-Peak (QP)
FREQUENCY RANGE	9kHz ~ 1GHz	TEST MODE	A

ANTENNA POLARITY & TEST DISTANCE: VERTICAL AT 3 M								
NO.	FREQ. (MHz)	EMISSION LEVEL (dBuV/m)	LIMIT (dBuV/m)	MARGIN (dB)	ANTENNA HEIGHT (m)	TABLE ANGLE (Degree)	RAW VALUE (dBuV)	CORRECTION FACTOR (dB/m)
1	59.52	38.6 QP	40.0	-1.4	1.00 V	54	47.8	-9.2
2	96.07	39.4 QP	43.5	-4.1	1.00 V	140	53.1	-13.7
3	119.97	38.7 QP	43.5	-4.8	1.00 V	43	49.6	-10.9
4	239.46	35.8 QP	46.0	-10.2	1.00 V	195	45.7	-9.9
5	387.07	38.6 QP	46.0	-7.4	1.00 V	6	43.5	-4.9
6	450.33	40.3 QP	46.0	-5.7	1.00 V	130	42.9	-2.6

Remarks:

1. Emission Level(dBuV/m) = Raw Value(dBuV) + Correction Factor(dB/m).
2. Correction Factor(dB/m) = Antenna Factor(dB/m) + Cable Factor(dB) – Pre-Amplifier Factor(dB).
3. The other emission levels were very low against the limit.
4. Margin value = Emission Level – Limit value.
5. The emission levels were very low against the limit of frequency range 9kHz ~ 30MHz :the amplitude of spurious emissions attenuated more than 20 dB below the permissible value to be report.

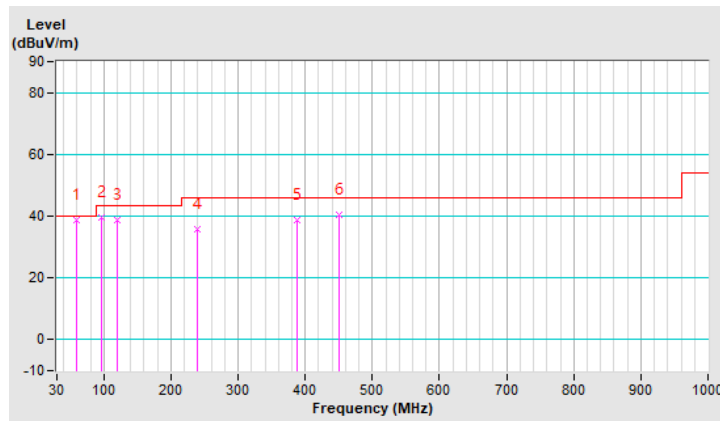

CHANNEL	TX Channel 8	DETECTOR FUNCTION	Quasi-Peak (QP)
FREQUENCY RANGE	9kHz ~ 1GHz	TEST MODE	A

ANTENNA POLARITY & TEST DISTANCE: HORIZONTAL AT 3 M								
NO.	FREQ. (MHz)	EMISSION LEVEL (dBuV/m)	LIMIT (dBuV/m)	MARGIN (dB)	ANTENNA HEIGHT (m)	TABLE ANGLE (Degree)	RAW VALUE (dBuV)	CORRECTION FACTOR (dB/m)
1	164.96	36.5 QP	43.5	-7.0	1.49 H	172	45.2	-8.7
2	191.67	39.0 QP	43.5	-4.5	1.49 H	240	50.3	-11.3
3	239.46	38.5 QP	46.0	-7.5	1.00 H	211	48.4	-9.9
4	387.07	39.4 QP	46.0	-6.6	1.00 H	14	44.3	-4.9
5	426.43	40.9 QP	46.0	-5.1	2.00 H	169	44.3	-3.4
6	499.54	42.0 QP	46.0	-4.0	1.49 H	225	43.5	-1.5

Remarks:

1. Emission Level(dBuV/m) = Raw Value(dBuV) + Correction Factor(dB/m).
2. Correction Factor(dB/m) = Antenna Factor(dB/m) + Cable Factor(dB) – Pre-Amplifier Factor(dB).
3. The other emission levels were very low against the limit.
4. Margin value = Emission Level – Limit value.
5. The emission levels were very low against the limit of frequency range 9kHz ~ 30MHz :the amplitude of spurious emissions attenuated more than 20 dB below the permissible value to be report.

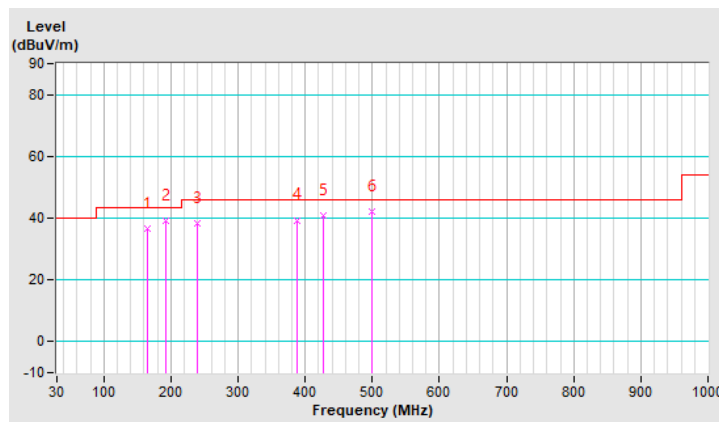

CHANNEL	TX Channel 8	DETECTOR FUNCTION	Quasi-Peak (QP)
FREQUENCY RANGE	9kHz ~ 1GHz	TEST MODE	A

ANTENNA POLARITY & TEST DISTANCE: VERTICAL AT 3 M								
NO.	FREQ. (MHz)	EMISSION LEVEL (dBuV/m)	LIMIT (dBuV/m)	MARGIN (dB)	ANTENNA HEIGHT (m)	TABLE ANGLE (Degree)	RAW VALUE (dBuV)	CORRECTION FACTOR (dB/m)
1	35.62	35.2 QP	40.0	-4.8	1.00 V	220	45.3	-10.1
2	96.07	41.0 QP	43.5	-2.5	1.00 V	116	54.7	-13.7
3	119.97	39.7 QP	43.5	-3.8	1.00 V	27	50.6	-10.9
4	191.67	38.4 QP	43.5	-5.1	1.00 V	15	49.7	-11.3
5	387.07	42.1 QP	46.0	-3.9	1.00 V	15	47.0	-4.9
6	450.33	40.5 QP	46.0	-5.5	1.00 V	15	43.1	-2.6

Remarks:

1. Emission Level(dBuV/m) = Raw Value(dBuV) + Correction Factor(dB/m).
2. Correction Factor(dB/m) = Antenna Factor(dB/m) + Cable Factor(dB) – Pre-Amplifier Factor(dB).
3. The other emission levels were very low against the limit.
4. Margin value = Emission Level – Limit value.
5. The emission levels were very low against the limit of frequency range 9kHz ~ 30MHz :the amplitude of spurious emissions attenuated more than 20 dB below the permissible value to be report.

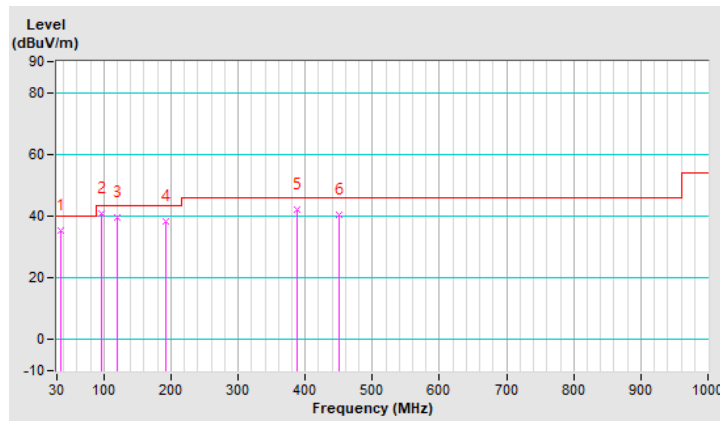

CHANNEL	TX Channel 1	DETECTOR FUNCTION	Quasi-Peak (QP)
FREQUENCY RANGE	9kHz ~ 1GHz	TEST MODE	B

ANTENNA POLARITY & TEST DISTANCE: HORIZONTAL AT 3 M								
NO.	FREQ. (MHz)	EMISSION LEVEL (dBuV/m)	LIMIT (dBuV/m)	MARGIN (dB)	ANTENNA HEIGHT (m)	TABLE ANGLE (Degree)	RAW VALUE (dBuV)	CORRECTION FACTOR (dB/m)
1	166.36	40.0 QP	43.5	-3.5	1.00 H	226	48.7	-8.7
2	239.46	36.8 QP	46.0	-9.2	1.50 H	87	46.7	-9.9
3	387.07	36.8 QP	46.0	-9.2	1.00 H	72	41.7	-4.9
4	450.33	37.4 QP	46.0	-8.6	1.50 H	208	40.0	-2.6
5	499.54	43.1 QP	46.0	-2.9	1.50 H	65	44.6	-1.5
6	737.12	41.0 QP	46.0	-5.0	2.00 H	42	38.2	2.8

Remarks:

1. Emission Level(dBuV/m) = Raw Value(dBuV) + Correction Factor(dB/m).
2. Correction Factor(dB/m) = Antenna Factor(dB/m) + Cable Factor(dB) – Pre-Amplifier Factor(dB).
3. The other emission levels were very low against the limit.
4. Margin value = Emission Level – Limit value.
5. The emission levels were very low against the limit of frequency range 9kHz ~ 30MHz :the amplitude of spurious emissions attenuated more than 20 dB below the permissible value to be report.

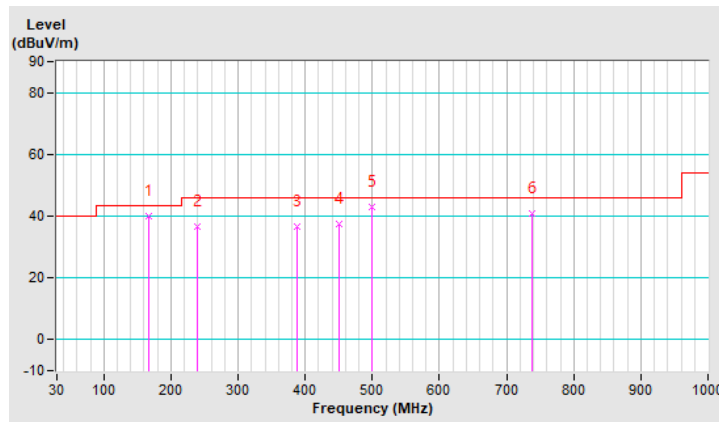

CHANNEL	TX Channel 1	DETECTOR FUNCTION	Quasi-Peak (QP)
FREQUENCY RANGE	9kHz ~ 1GHz	TEST MODE	B

ANTENNA POLARITY & TEST DISTANCE: VERTICAL AT 3 M								
NO.	FREQ. (MHz)	EMISSION LEVEL (dBuV/m)	LIMIT (dBuV/m)	MARGIN (dB)	ANTENNA HEIGHT (m)	TABLE ANGLE (Degree)	RAW VALUE (dBuV)	CORRECTION FACTOR (dB/m)
1	72.00	38.9 QP	40.0	-1.1	1.00 V	327	50.2	-11.3
2	131.22	36.1 QP	43.5	-7.4	1.00 V	163	46.0	-9.9
3	166.36	41.5 QP	43.5	-2.0	1.00 V	199	50.2	-8.7
4	239.46	42.1 QP	46.0	-3.9	1.00 V	10	52.0	-9.9
5	387.07	44.3 QP	46.0	-1.7	1.49 V	11	49.2	-4.9
6	450.33	41.5 QP	46.0	-4.5	1.49 V	300	44.1	-2.6

Remarks:

1. Emission Level(dBuV/m) = Raw Value(dBuV) + Correction Factor(dB/m).
2. Correction Factor(dB/m) = Antenna Factor(dB/m) + Cable Factor(dB) – Pre-Amplifier Factor(dB).
3. The other emission levels were very low against the limit.
4. Margin value = Emission Level – Limit value.
5. The emission levels were very low against the limit of frequency range 9kHz ~ 30MHz :the amplitude of spurious emissions attenuated more than 20 dB below the permissible value to be report.

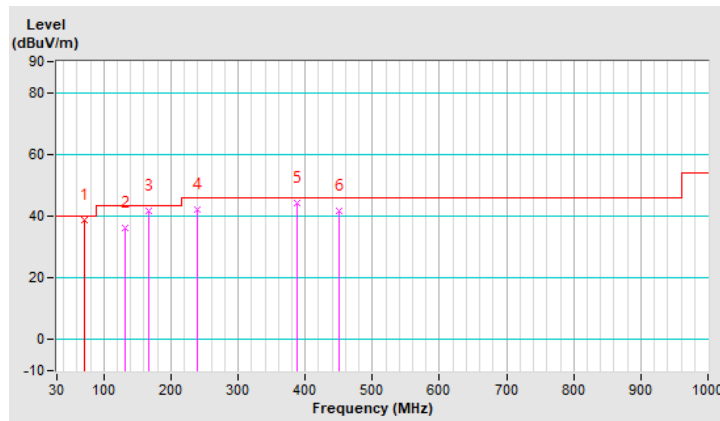

CHANNEL	TX Channel 4	DETECTOR FUNCTION	Quasi-Peak (QP)
FREQUENCY RANGE	9kHz ~ 1GHz	TEST MODE	B

ANTENNA POLARITY & TEST DISTANCE: HORIZONTAL AT 3 M								
NO.	FREQ. (MHz)	EMISSION LEVEL (dBuV/m)	LIMIT (dBuV/m)	MARGIN (dB)	ANTENNA HEIGHT (m)	TABLE ANGLE (Degree)	RAW VALUE (dBuV)	CORRECTION FACTOR (dB/m)
1	166.36	39.8 QP	43.5	-3.7	1.50 H	226	48.5	-8.7
2	239.46	36.4 QP	46.0	-9.6	1.50 H	100	46.3	-9.9
3	384.26	35.1 QP	46.0	-10.9	1.00 H	25	40.0	-4.9
4	432.06	35.8 QP	46.0	-10.2	1.50 H	148	38.9	-3.1
5	499.54	42.7 QP	46.0	-3.3	1.00 H	57	44.2	-1.5
6	624.65	36.7 QP	46.0	-9.3	1.50 H	139	35.3	1.4

Remarks:

1. Emission Level(dBuV/m) = Raw Value(dBuV) + Correction Factor(dB/m).
2. Correction Factor(dB/m) = Antenna Factor(dB/m) + Cable Factor(dB) – Pre-Amplifier Factor(dB).
3. The other emission levels were very low against the limit.
4. Margin value = Emission Level – Limit value.
5. The emission levels were very low against the limit of frequency range 9kHz ~ 30MHz :the amplitude of spurious emissions attenuated more than 20 dB below the permissible value to be report.

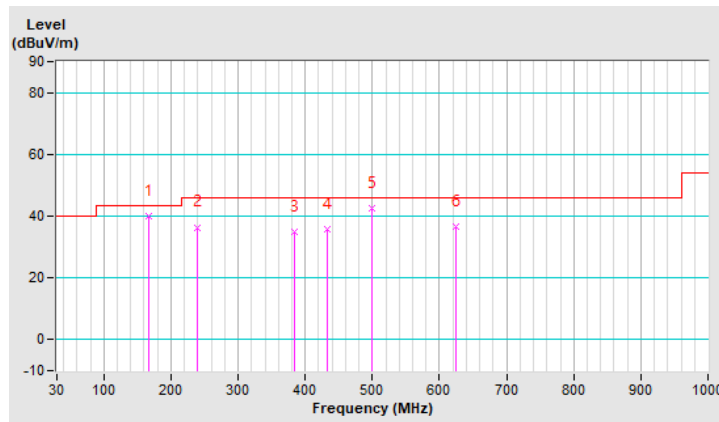

CHANNEL	TX Channel 4	DETECTOR FUNCTION	Quasi-Peak (QP)
FREQUENCY RANGE	9kHz ~ 1GHz	TEST MODE	B

ANTENNA POLARITY & TEST DISTANCE: VERTICAL AT 3 M								
NO.	FREQ. (MHz)	EMISSION LEVEL (dBuV/m)	LIMIT (dBuV/m)	MARGIN (dB)	ANTENNA HEIGHT (m)	TABLE ANGLE (Degree)	RAW VALUE (dBuV)	CORRECTION FACTOR (dB/m)
1	70.77	38.2 QP	40.0	-1.8	1.00 V	308	49.1	-10.9
2	96.07	39.5 QP	43.5	-4.0	1.50 V	61	53.2	-13.7
3	166.36	41.5 QP	43.5	-2.0	2.00 V	190	50.2	-8.7
4	239.46	39.0 QP	46.0	-7.0	1.00 V	8	48.9	-9.9
5	387.07	44.3 QP	46.0	-1.7	1.50 V	41	49.2	-4.9
6	450.33	39.9 QP	46.0	-6.1	1.50 V	313	42.5	-2.6

Remarks:

1. Emission Level(dBuV/m) = Raw Value(dBuV) + Correction Factor(dB/m).
2. Correction Factor(dB/m) = Antenna Factor(dB/m) + Cable Factor(dB) – Pre-Amplifier Factor(dB).
3. The other emission levels were very low against the limit.
4. Margin value = Emission Level – Limit value.
5. The emission levels were very low against the limit of frequency range 9kHz ~ 30MHz :the amplitude of spurious emissions attenuated more than 20 dB below the permissible value to be report.

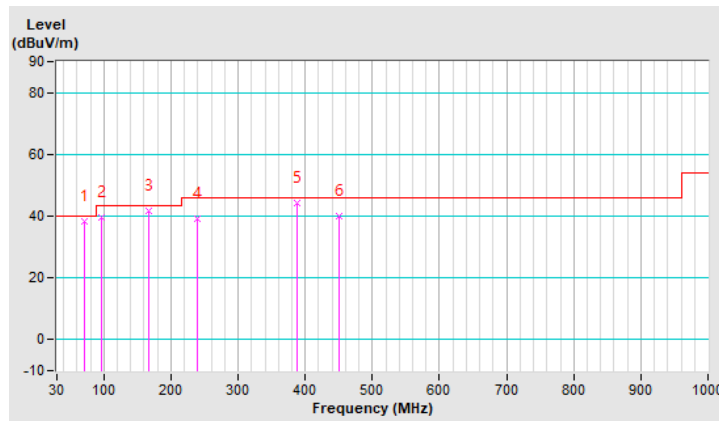

CHANNEL	TX Channel 8	DETECTOR FUNCTION	Quasi-Peak (QP)
FREQUENCY RANGE	9kHz ~ 1GHz	TEST MODE	B

ANTENNA POLARITY & TEST DISTANCE: HORIZONTAL AT 3 M								
NO.	FREQ. (MHz)	EMISSION LEVEL (dBuV/m)	LIMIT (dBuV/m)	MARGIN (dB)	ANTENNA HEIGHT (m)	TABLE ANGLE (Degree)	RAW VALUE (dBuV)	CORRECTION FACTOR (dB/m)
1	44.06	30.9 QP	40.0	-9.1	1.00 H	231	39.9	-9.0
2	166.36	40.3 QP	43.5	-3.2	1.50 H	233	49.0	-8.7
3	239.46	37.2 QP	46.0	-8.8	1.50 H	89	47.1	-9.9
4	387.07	35.6 QP	46.0	-10.4	2.00 H	340	40.5	-4.9
5	450.33	36.5 QP	46.0	-9.5	1.00 H	203	39.1	-2.6
6	499.54	43.2 QP	46.0	-2.8	1.50 H	64	44.7	-1.5

Remarks:

1. Emission Level(dBuV/m) = Raw Value(dBuV) + Correction Factor(dB/m).
2. Correction Factor(dB/m) = Antenna Factor(dB/m) + Cable Factor(dB) – Pre-Amplifier Factor(dB).
3. The other emission levels were very low against the limit.
4. Margin value = Emission Level – Limit value.
5. The emission levels were very low against the limit of frequency range 9kHz ~ 30MHz :the amplitude of spurious emissions attenuated more than 20 dB below the permissible value to be report.

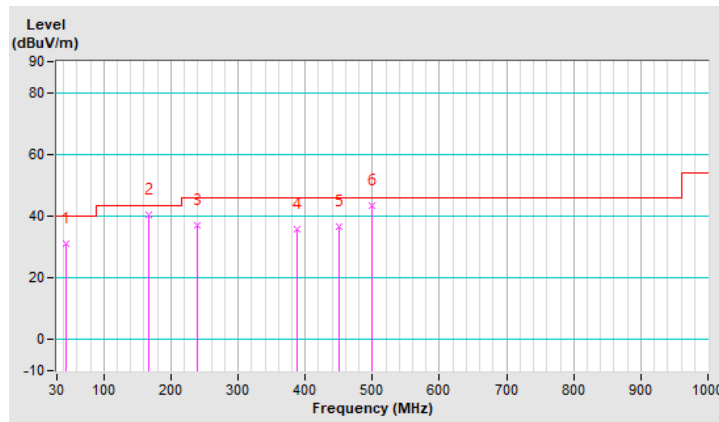

CHANNEL	TX Channel 8	DETECTOR FUNCTION	Quasi-Peak (QP)
FREQUENCY RANGE	9kHz ~ 1GHz	TEST MODE	B

ANTENNA POLARITY & TEST DISTANCE: VERTICAL AT 3 M								
NO.	FREQ. (MHz)	EMISSION LEVEL (dBuV/m)	LIMIT (dBuV/m)	MARGIN (dB)	ANTENNA HEIGHT (m)	TABLE ANGLE (Degree)	RAW VALUE (dBuV)	CORRECTION FACTOR (dB/m)
1	70.77	38.0 QP	40.0	-2.0	1.00 V	325	48.9	-10.9
2	96.07	39.6 QP	43.5	-3.9	1.50 V	60	53.3	-13.7
3	166.36	41.9 QP	43.5	-1.6	1.00 V	179	50.6	-8.7
4	239.46	38.6 QP	46.0	-7.4	1.50 V	11	48.5	-9.9
5	387.07	40.2 QP	46.0	-5.8	2.00 V	119	45.1	-4.9
6	450.33	40.4 QP	46.0	-5.6	1.50 V	296	43.0	-2.6

Remarks:

1. Emission Level(dBuV/m) = Raw Value(dBuV) + Correction Factor(dB/m).
2. Correction Factor(dB/m) = Antenna Factor(dB/m) + Cable Factor(dB) – Pre-Amplifier Factor(dB).
3. The other emission levels were very low against the limit.
4. Margin value = Emission Level – Limit value.
5. The emission levels were very low against the limit of frequency range 9kHz ~ 30MHz :the amplitude of spurious emissions attenuated more than 20 dB below the permissible value to be report.

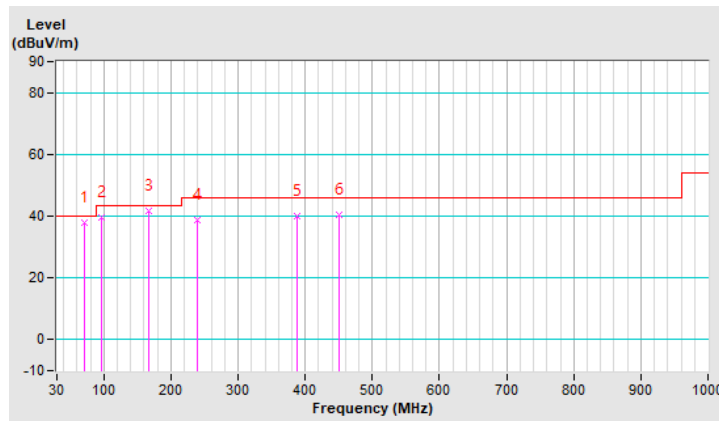

4.2 Conducted Emission Measurement

4.2.1 Limits of Conducted Emission Measurement

Frequency (MHz)	Conducted Limit (dBuV)	
	Quasi-peak	Average
0.15 - 0.5	66 - 56	56 - 46
0.50 - 5.0	56	46
5.0 - 30.0	60	50

- Note: 1. The lower limit shall apply at the transition frequencies.
 2. The limit decreases in line with the logarithm of the frequency in the range of 0.15 to 0.50MHz.

4.2.2 Test Instruments

Description & Manufacturer	Model No.	Serial No.	Cal. Date	Cal. Due
Test Receiver ROHDE & SCHWARZ	ESR3	102412	Feb. 17, 2020	Feb. 16, 2021
RF signal cable (with 10dB PAD) Woken	5D-FB	Cable-cond2-01	Sep. 05, 2019	Sep. 04, 2020
LISN ROHDE & SCHWARZ (EUT)	ESH2-Z5	100100	Jan. 20, 2020	Jan. 19, 2021
LISN ROHDE & SCHWARZ (Peripheral)	ESH3-Z5	100312	Aug. 13, 2019	Aug. 12, 2020
Software ADT	BV ADT_Cond_ V7.3.7.4	NA	NA	NA

- Note: 1. The calibration interval of the above test instruments is 12 months and the calibrations are traceable to NML/ROC and NIST/USA.
 2. The test was performed in HwaYa Shielded Room 2 (Conduction 2).
 3. The VCCI Site Registration No. is C-12047.

4.2.3 Test Procedures

- The EUT was placed 0.4 meters from the conducting wall of the shielded room with EUT being connected to the power mains through a line impedance stabilization network (LISN). Other support units were connected to the power mains through another LISN. The two LISNs provide 50 ohm/ 50uH of coupling impedance for the measuring instrument.
- Both lines of the power mains connected to the EUT were checked for maximum conducted interference.
- The frequency range from 150kHz to 30MHz was searched. Emission levels under (Limit - 20dB) was not recorded.

Note: The resolution bandwidth and video bandwidth of test receiver is 9kHz for quasi-peak detection (QP) and average detection (AV) at frequency 0.15MHz-30MHz.

4.2.4 Deviation from Test Standard

No deviation.

4.2.5 Test Setup

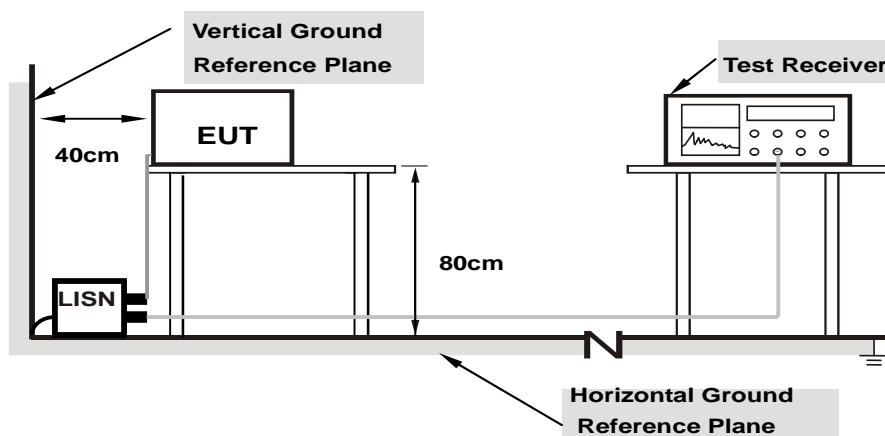

Note: 1.Support units were connected to second LISN.

For the actual test configuration, please refer to the attached file (Test Setup Photo).

4.2.6 EUT Operating Condition

Same as 4.1.6.

4.2.7 Test Results

Channel	TX Channel 1	Phase	Line (L)
Detector Function	Quasi-Peak (QP) / Average (AV)	Test Mode	A

No	Freq. [MHz]	Corr. Factor (dB)	Reading Value [dB (uV)]		Emission Level [dB (uV)]		Limit [dB (uV)]		Margin (dB)	
			Q.P.	AV.	Q.P.	AV.	Q.P.	AV.	Q.P.	AV.
			1	0.15000	10.24	36.66	22.07	46.90	32.31	66.00
2	0.17700	10.26	41.90	31.46	52.16	41.72	64.63	54.63	-12.47	-12.91
3	0.33885	10.30	34.88	29.15	45.18	39.45	59.23	49.23	-14.05	-9.78
4	1.01175	10.42	34.45	30.91	44.87	41.33	56.00	46.00	-11.13	-4.67
5	1.77000	10.47	31.23	27.60	41.70	38.07	56.00	46.00	-14.30	-7.93
6	2.27625	10.50	29.53	27.58	40.03	38.08	56.00	46.00	-15.97	-7.92

Remarks:

1. Q.P. and AV. are abbreviations of quasi-peak and average individually.
2. The emission levels of other frequencies were very low against the limit.
3. Margin value = Emission level - Limit value
4. Correction factor = Insertion loss + Cable loss
5. Emission Level = Correction Factor + Reading Value.

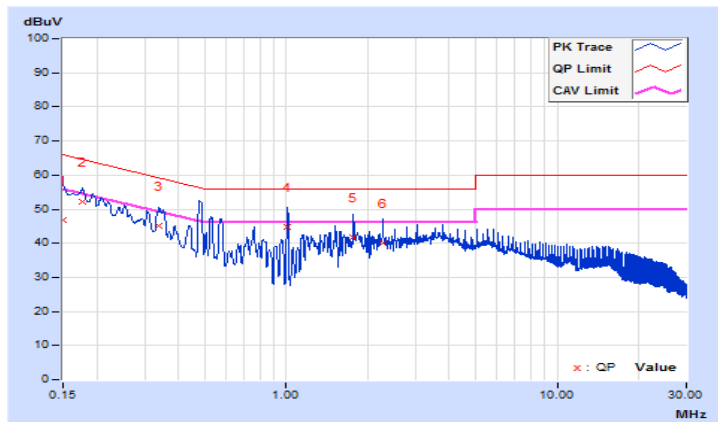

Channel	TX Channel 1	Phase	Neutral (N)
Detector Function	Quasi-Peak (QP) / Average (AV)	Test Mode	A

No	Freq. [MHz]	Corr. Factor (dB)	Reading Value [dB (uV)]		Emission Level [dB (uV)]		Limit [dB (uV)]		Margin (dB)	
			Q.P.	AV.	Q.P.	AV.	Q.P.	AV.	Q.P.	AV.
			1	0.15225	10.22	34.99	17.89	45.21	28.11	65.88
2	0.57280	10.33	33.50	31.92	43.83	42.25	56.00	46.00	-12.17	-3.75
3	1.01175	10.42	34.62	30.64	45.04	41.06	56.00	46.00	-10.96	-4.94
4	1.77000	10.46	31.82	27.65	42.28	38.11	56.00	46.00	-13.72	-7.89
5	2.27625	10.49	29.86	27.53	40.35	38.02	56.00	46.00	-15.65	-7.98
6	3.79500	10.60	27.80	24.29	38.40	34.89	56.00	46.00	-17.60	-11.11

Remarks:

1. Q.P. and AV. are abbreviations of quasi-peak and average individually.
2. The emission levels of other frequencies were very low against the limit.
3. Margin value = Emission level - Limit value
4. Correction factor = Insertion loss + Cable loss
5. Emission Level = Correction Factor + Reading Value.

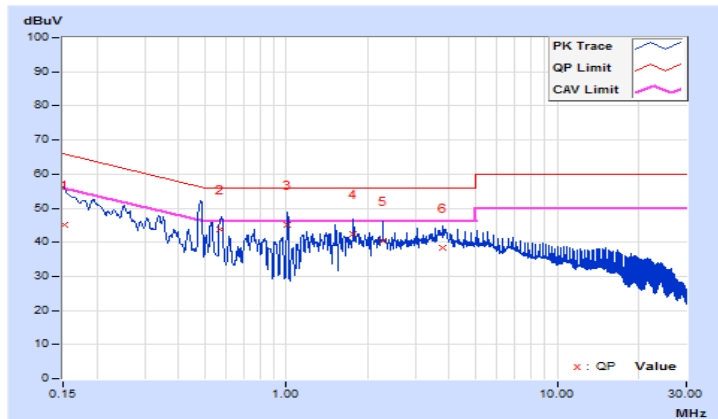

Channel	TX Channel 1	Phase	Line (L)
Detector Function	Quasi-Peak (QP) / Average (AV)	Test Mode	B

No	Freq. [MHz]	Corr. Factor (dB)	Reading Value [dB (uV)]		Emission Level [dB (uV)]		Limit [dB (uV)]		Margin (dB)	
			Q.P.	AV.	Q.P.	AV.	Q.P.	AV.	Q.P.	AV.
			1	0.15225	10.24	35.24	18.53	45.48	28.77	65.88
2	0.33885	10.30	35.16	31.78	45.46	42.08	59.23	49.23	-13.77	-7.15
3	0.52830	10.34	34.72	33.59	45.06	43.93	56.00	46.00	-10.94	-2.07
4	0.57154	10.35	35.68	34.04	46.03	44.39	56.00	46.00	-9.97	-1.61
5	3.78150	10.59	26.89	16.42	37.48	27.01	56.00	46.00	-18.52	-18.99
6	5.57025	10.63	23.42	11.91	34.05	22.54	60.00	50.00	-25.95	-27.46

Remarks:

1. Q.P. and AV. are abbreviations of quasi-peak and average individually.
2. The emission levels of other frequencies were very low against the limit.
3. Margin value = Emission level - Limit value
4. Correction factor = Insertion loss + Cable loss
5. Emission Level = Correction Factor + Reading Value.

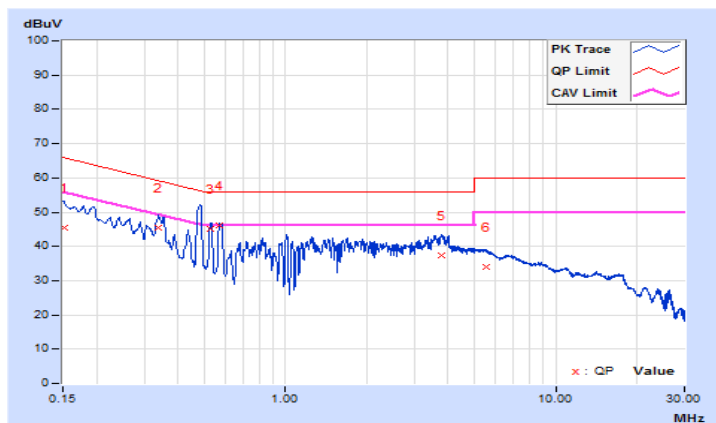

Channel	TX Channel 1	Phase	Neutral (N)
Detector Function	Quasi-Peak (QP) / Average (AV)	Test Mode	B

No	Freq. [MHz]	Corr. Factor (dB)	Reading Value [dB (uV)]		Emission Level [dB (uV)]		Limit [dB (uV)]		Margin (dB)	
			Q.P.	AV.	Q.P.	AV.	Q.P.	AV.	Q.P.	AV.
			1	0.19006	10.24	40.16	33.27	50.40	43.51	64.03
2	0.33706	10.28	36.52	30.53	46.80	40.81	59.28	49.28	-12.48	-8.47
3	0.52280	10.32	34.14	31.87	44.46	42.19	56.00	46.00	-11.54	-3.81
4	0.57250	10.33	34.77	33.15	45.10	43.48	56.00	46.00	-10.90	-2.52
5	3.78502	10.60	26.99	17.10	37.59	27.70	56.00	46.00	-18.41	-18.30
6	5.50275	10.67	24.75	13.52	35.42	24.19	60.00	50.00	-24.58	-25.81

Remarks:

1. Q.P. and AV. are abbreviations of quasi-peak and average individually.
2. The emission levels of other frequencies were very low against the limit.
3. Margin value = Emission level - Limit value
4. Correction factor = Insertion loss + Cable loss
5. Emission Level = Correction Factor + Reading Value.

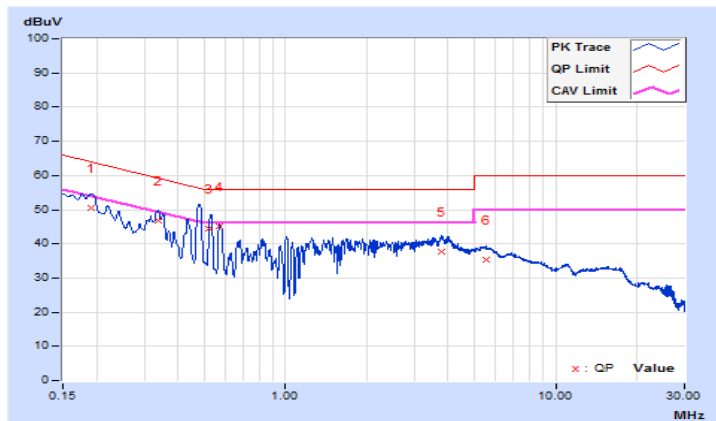

4.3 6dB Bandwidth Measurement

4.3.1 Limits of 6dB Bandwidth Measurement

The minimum of 6dB Bandwidth Measurement is 0.5 MHz.

4.3.2 Test Setup

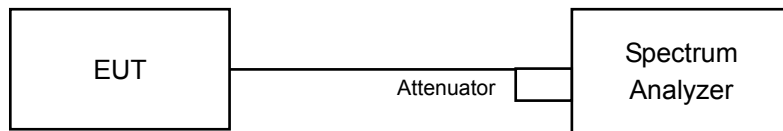

4.3.3 Test Instruments

Refer to section 4.1.2 to get information of above instrument.

4.3.4 Test Procedure

- Set resolution bandwidth (RBW) = 100kHz.
- Set the video bandwidth (VBW) $\geq 3 \times$ RBW, Detector = peak.
- Trace mode = max hold.
- Sweep = auto couple.
- Measure the maximum width of the emission that is constrained by the frequencies associated with the two amplitude points (upper and lower) that are attenuated by 6 dB relative to the maximum level measured in the fundamental emission.

4.3.5 Deviation from Test Standard

No deviation.

4.3.6 EUT Operating Conditions

The software provided by client to enable the EUT under transmission condition continuously at lowest, middle and highest channel frequencies individually.

4.3.7 Test Result

Channel	Frequency (MHz)	6dB Bandwidth (MHz)	Minimum Limit (MHz)	Pass / Fail
1	923.3	0.61	0.5	Pass
4	925.1	0.61	0.5	Pass
8	927.5	0.61	0.5	Pass

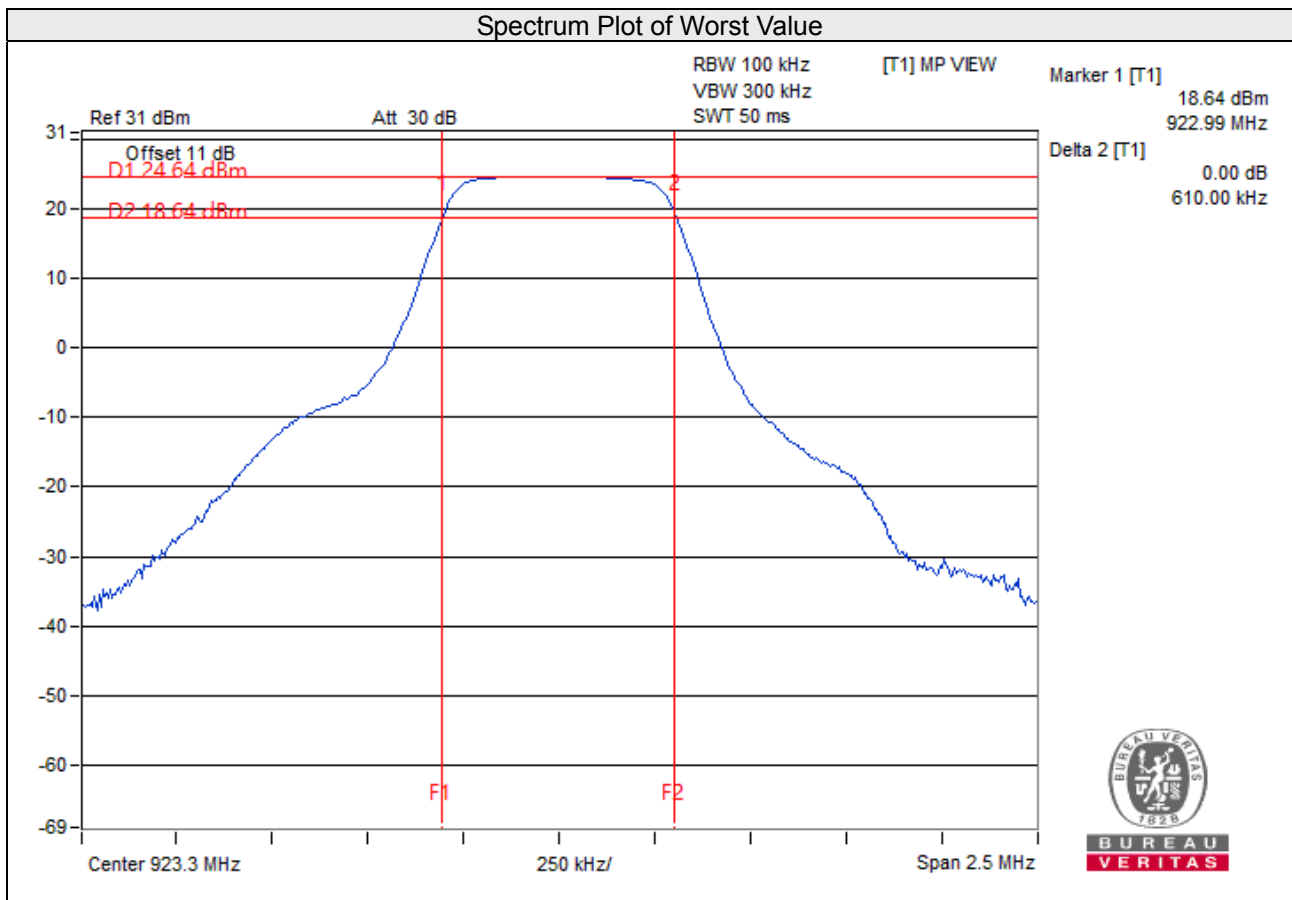

4.4 Conducted Output Power Measurement

4.4.1 Limits of Conducted Output Power Measurement

For systems using digital modulation in the 902-928 MHz bands: 1 Watt (30dBm)

4.4.2 Test Setup

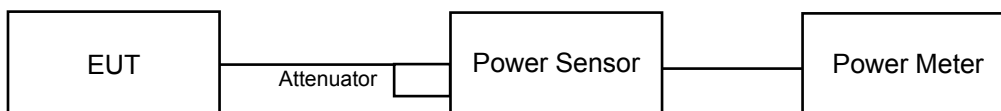

4.4.3 Test Instruments

Refer to section 4.1.2 to get information of above instrument.

4.4.4 Test Procedure

For peak power:

A peak power sensor was used on the output port of the EUT. A power meter was used to read the response of the peak power sensor. Record the power level.

For average power:

An average power sensor was used on the output port of the EUT. A power meter was used to read the response of the average power sensor. Record the power level.

4.4.5 Deviation from Test Standard

No deviation.

4.4.6 EUT Operating Condition

The software provided by client enabled the EUT to transmit and receive data at lowest, middle and highest channel frequencies individually.

4.4.7 Test Results

For peak power:

Channel	Frequency (MHz)	Peak Power (mW)	Peak Power (dBm)	Power Limit (dBm)	Pass / Fail
1	923.3	299.916	24.77	30	Pass
4	925.1	262.422	24.19	30	Pass
8	927.5	257.632	24.11	30	Pass

For average power:

Channel	Frequency (MHz)	Average Power (mW)	Average Power (dBm)
1	923.3	295.801	24.71
4	925.1	257.632	24.11
8	927.5	251.768	24.01

4.5 Power Spectral Density Measurement

4.5.1 Limits of Power Spectral Density Measurement

The Maximum of Power Spectral Density Measurement is 8dBm in any 3 kHz band during any time interval of continuous transmission.

4.5.2 Test Setup

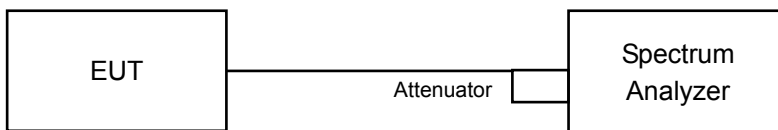

4.5.3 Test Instruments

Refer to section 4.1.2 to get information of above instrument.

4.5.4 Test Procedure

- a. Set instrument center frequency to DTS channel center frequency.
- b. Set span to at least 1.5 times the OBW.
- c. Set RBW to: $3 \text{ kHz} \leq \text{RBW} \leq 100 \text{ kHz}$.
- d. Set VBW $\geq 3 \times \text{RBW}$.
- e. Detector = peak.
- g. Sweep time = auto couple.
- h. Trace mode = max hold.
- i. Allow trace to fully stabilize.

4.5.5 Deviation from Test Standard

No deviation.

4.5.6 EUT Operating Condition

The software provided by client enabled the EUT to transmit and receive data at lowest, middle and highest channel frequencies individually.

4.5.7 Test Results

Channel	Freq. (MHz)	PSD (dBm/3kHz)	Limit (dBm/3kHz)	Pass / Fail
1	923.3	5.91	8	Pass
4	925.1	5.30	8	Pass
8	927.5	5.21	8	Pass

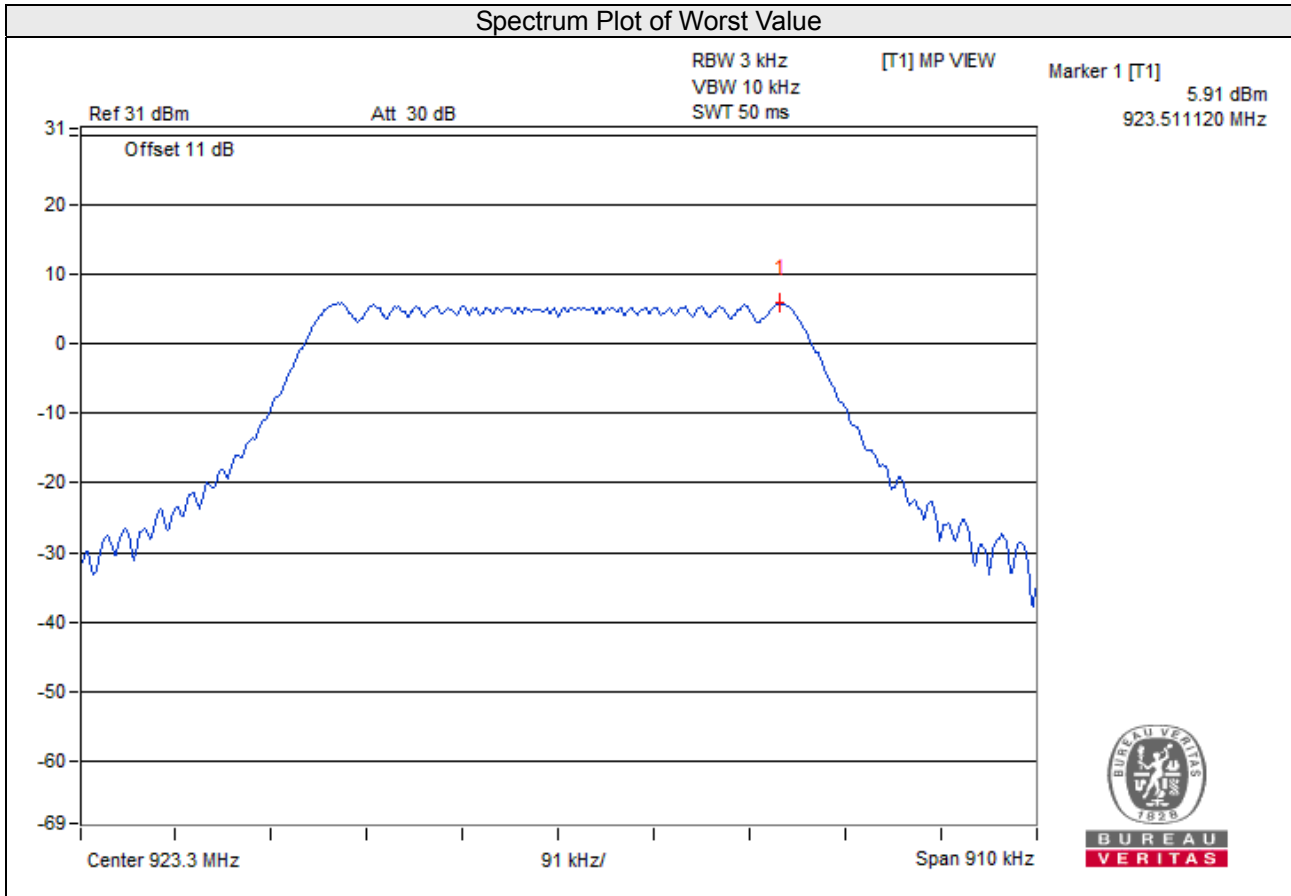

4.6 Conducted Out of Band Emission Measurement

4.6.1 Limits of Conducted Out Of Band Emission Measurement

Below -20dB of the highest emission level of operating band (in 100kHz Resolution Bandwidth).

4.6.2 Test Setup

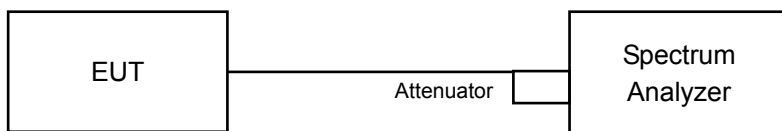

4.6.3 Test Instruments

Refer to section 4.1.2 to get information of above instrument.

4.6.4 Test Procedure

Measurement Procedure REF

- Set the RBW = 100 kHz.
- Set the VBW \geq 300 kHz.
- Detector = peak.
- Sweep time = auto couple.
- Trace mode = max hold.
- Allow trace to fully stabilize.
- Use the peak marker function to determine the maximum power level in any 100 kHz band segment within the fundamental EBW.

Measurement Procedure OOB

- Set RBW = 100 kHz.
- Set VBW \geq 300 kHz.
- Detector = peak.
- Sweep = auto couple.
- Trace Mode = max hold.
- Allow trace to fully stabilize.
- Use the peak marker function to determine the maximum amplitude level.

4.6.5 Deviation from Test Standard

No deviation.

4.6.6 EUT Operating Condition

The software provided by client enabled the EUT to transmit and receive data at lowest, middle and highest channel frequencies individually.

4.6.7 Test Results

The spectrum plots are attached on the following images. D1 line indicates the highest level, D2 line indicates the 20dB offset below D1. It shows compliance with the requirement.

CH 1

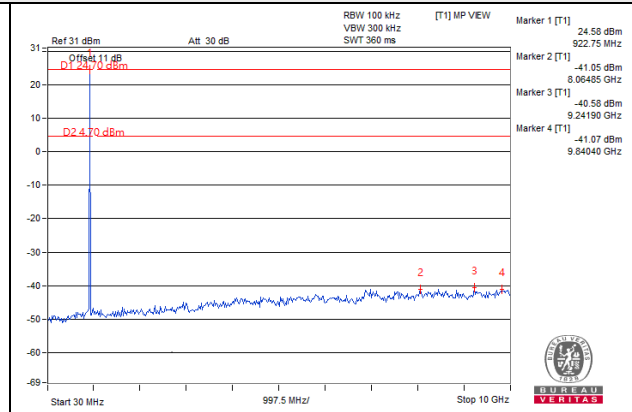
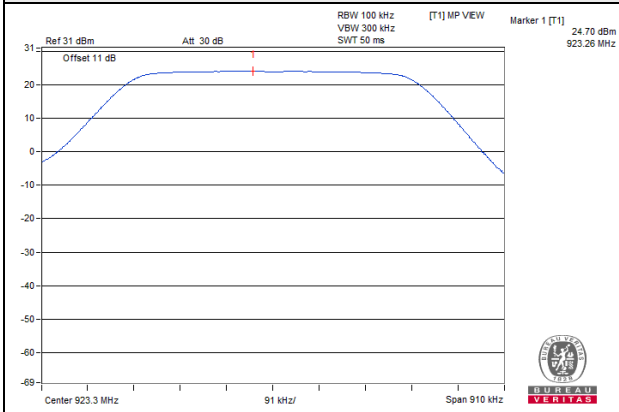

CH 8

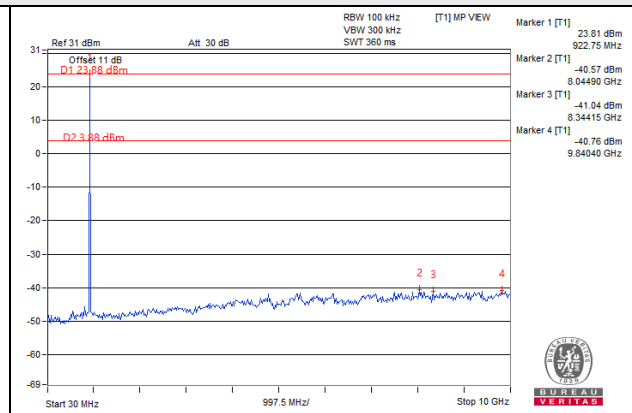
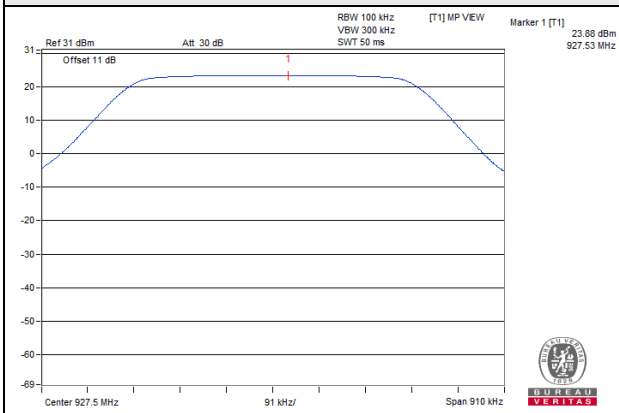

CH 1 Band edge

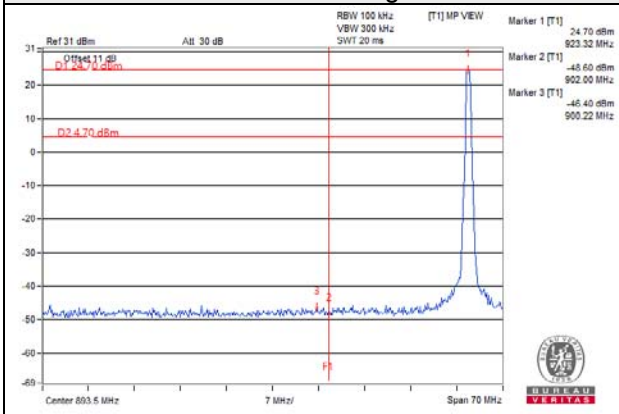

CH 8 Band edge

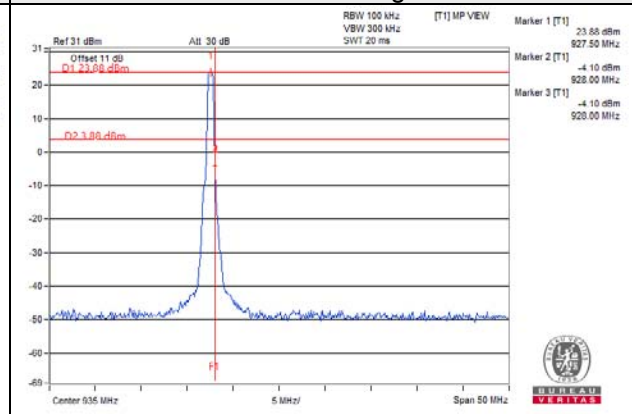

5 Pictures of Test Arrangements

Please refer to the attached file (Test Setup Photo).

Appendix – Information of the Testing Laboratories

We, Bureau Veritas Consumer Products Services (H.K.) Ltd., Taoyuan Branch, were founded in 1988 to provide our best service in EMC, Radio, Telecom and Safety consultation. Our laboratories are FCC recognized accredited test firms and accredited and approved according to ISO/IEC 17025.

If you have any comments, please feel free to contact us at the following:

Lin Kou EMC/RF Lab

Tel: 886-2-26052180

Fax: 886-2-26051924

Hsin Chu EMC/RF/Telecom Lab

Tel: 886-3-6668565

Fax: 886-3-6668323

Hwa Ya EMC/RF/Safety Lab

Tel: 886-3-3183232

Fax: 886-3-3270892

Email: service.adt@tw.bureauveritas.com

Web Site: www.bureauveritas-adt.com

The address and road map of all our labs can be found in our web site also.

--- END ---