

A

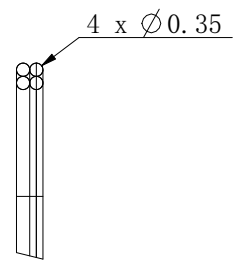

A
5:1

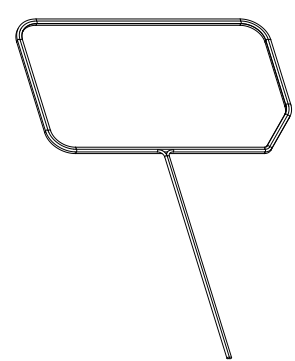

B

C

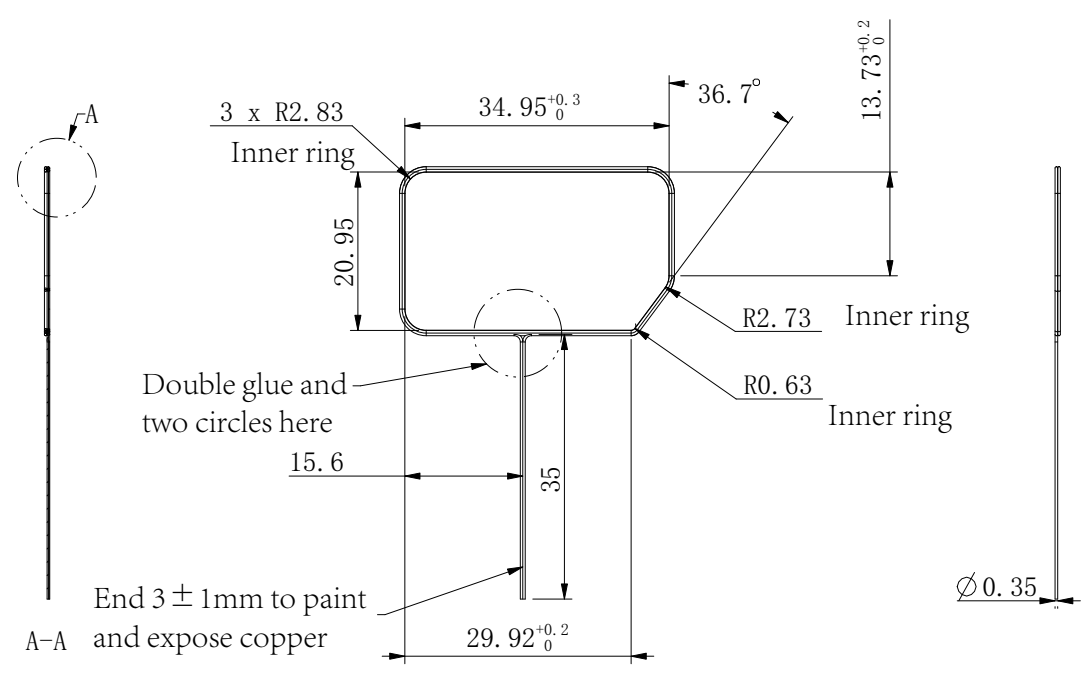

D

E

Skills requirement:

1. The material uses enameled wire, and the thickness of the enameled wire including the paint surface is 0.35mm;
2. The antenna is pasted with acetone between each circle, and the incoming material needs to be tightly wound, not loose;
3. The outgoing end of the antenna needs to be twisted twice as shown in the figure;
4. For unannotated tolerances, please refer to the B file of the mold core tolerance table.

F

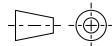
Dimensional tolerance not marked (angle $\pm 1^\circ$)				NIIMBOT精臣	
Size	A	B	C		
L ≤ 6	±0.05	±0.10	±0.20	1/1  V1.0	
6 < L ≤ 30	±0.10	±0.20	±0.30		
30 < L ≤ 80	±0.15	±0.30	±0.40		
80 < L ≤ 180	±0.20	±0.40	±0.50		
180 < L ≤ 315	±0.30	±0.50	±0.70		