

B21 Remembrance Printer User Manual

CONTENTS

1. Packing list
2. Component description
3. Charging issue
4. Indicator description
5. Settings
6. Consumables installation
7. Printing cleaning
8. Troubleshooting guide
9. Warnings
10. Notes
11. Software download
12. Warranties

Packing list

1. One printer
2. One USB TYPE-C cable
3. One user manual (including instructions, warranties and certificate)

02 Component description

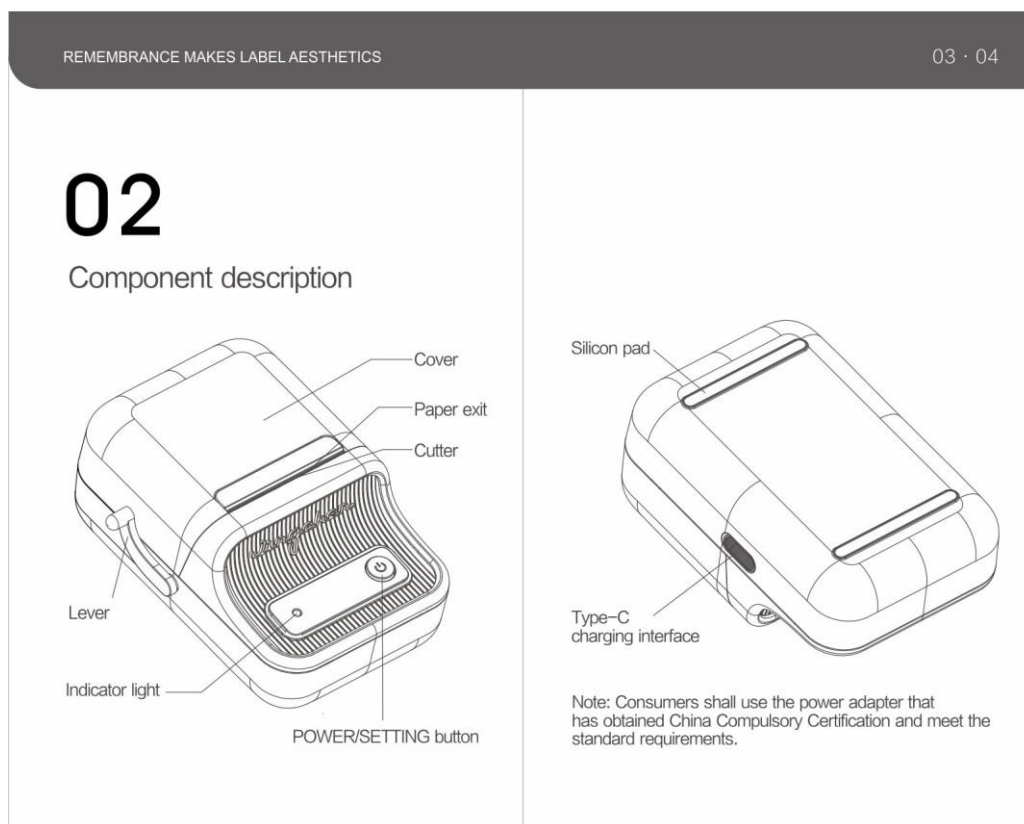

03 Charging Issue

Plug in the power adapter and USB TYPE-C cable. It is suggested to use 5V/2A power adapter

Consumers shall use the power adapter that has obtained China Compulsory Certification (CCC) and met the standard requirements.

04 Indicator description

Indicators	Status	Description
White light	Flashing	Firmware updating or other temporary status
White light	Steady light	Turning on the machine
Green light	Slow flashing	Charging finished
Green light	Flashing	Printing
Green light	Steady light	Bluetooth connected
Red light	Flashing	Malfunctions including but not limited to cover open, lack of paper, etc.
Red light	Steady light	Charging
Buzzer	Buzzing	It happens when turning on and off the printer.

05 Settings

1. Turn on the printer

Press and hold On/Off button for 2 seconds to turn on the printer.

2. Paper feed

Press On/Off button to feed the paper.

3 Self-test page printing

When the printer is on, press On/Off button to print self-test page

4 'Lack of paper' and 'Cover open' detection

'Lack of paper' and 'Cover open' status can be detected by the printer. In either situation, the printer does not response.

5. Low battery detection

The printer has low power detection and protection functions. When the printer is low on battery, it will shut down automatically.

6 Bluetooth connection

When the Bluetooth is connected, the mobile App will show corresponding indication.

7 When the USB is connected successfully, PC software will show corresponding indication.

8 Power indicator

When plugging in the power adaptor, the red light is on steadily.

9 Emergent stop

Stop the printing job by pressing On/Off button when printing.

06 Consumables installation

Step 1: Peel off the seal.

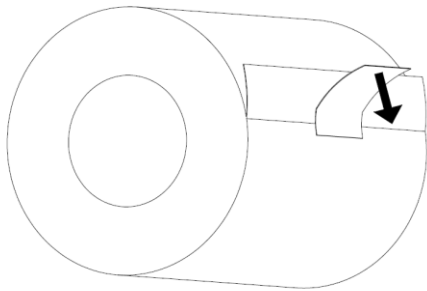

Step 2: Press down the lever to open the cover.

Step 3: Move apart the plates

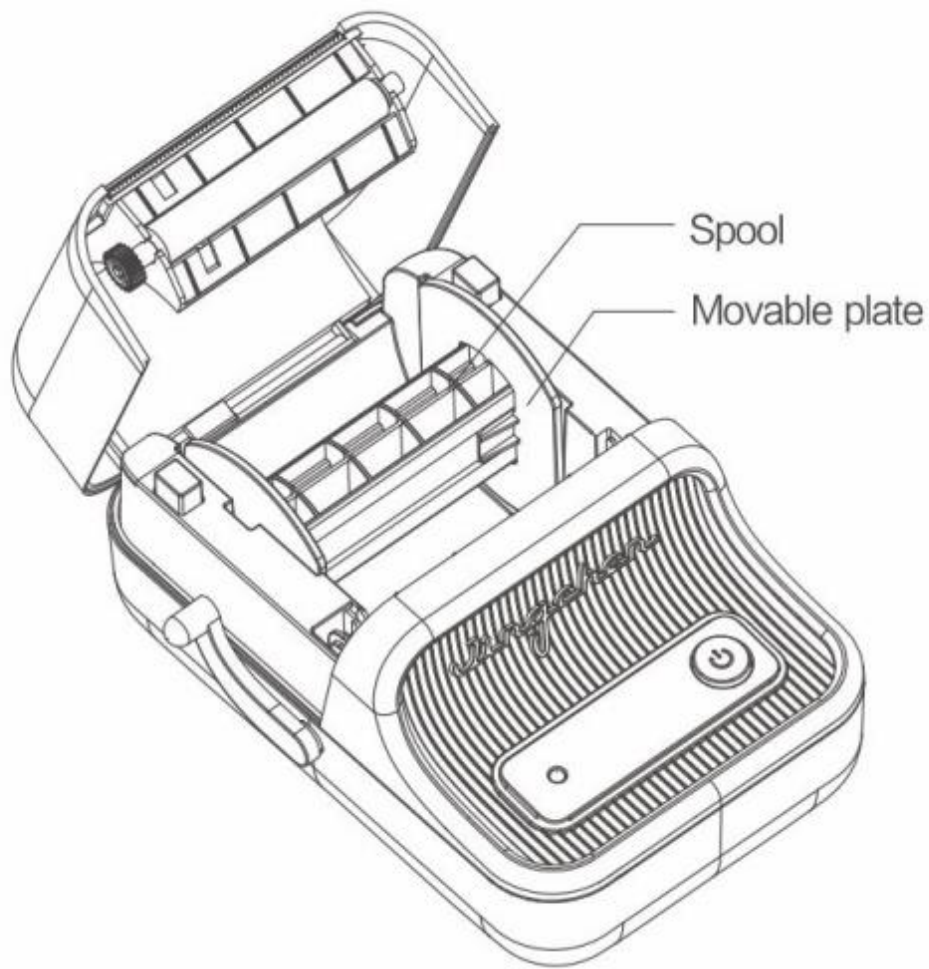

Step4: Load the paper and make the printing side face the print head.

Step5: After loading the paper, the plates must be fixed to avoid printing distortion. Close the cover with some paper left outside the cutter.

Note: If the paper is reversely laid, the printer will not response.

07 Cleaning issue

If any problem below arises, please clean some parts inside the printer:

1. Blurry printing
2. Loud noise when feeding and back feeding the paper
3. There is glue residue or dust sticking to the roll.

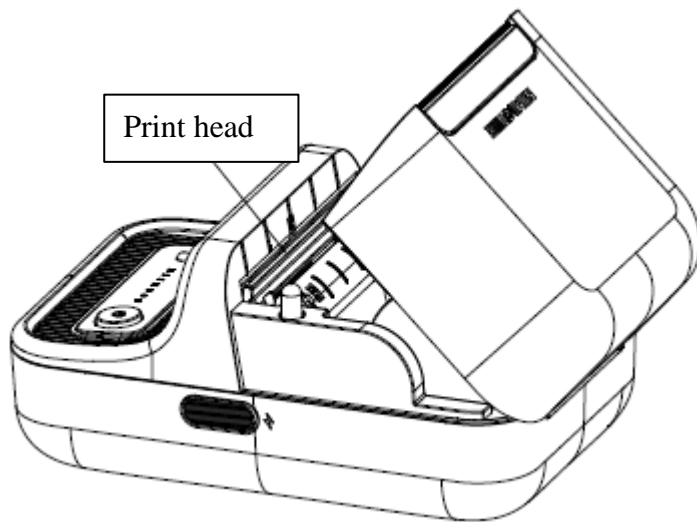

Cleaning procedures:

1. Turn off the printer
2. Wait the print head to cool off completely if printing job just finished. Open the cover to find the print head (see the picture);
3. Roll the platen and clean the dust or smudge on it with alcohol cotton ball (drained);
4. Clean the dust or smudge on the print head with alcohol cotton ball (drained) or an exclusive printer cleaning pen (needs to be purchased).
5. wait 5-10 minutes so that the alcohol has been volatilized before closing the cover.

Note:

- (1) Turn off the printer before cleaning.
- (2) Avoid touching the print head with hands or metal stuff. Do not scratch print head, platen or sensor surface with tweezers or similar stuff.
- (3) Do not clean print head or platen with organic solvent like petrol or acetone.
- (4) After alcohol has been volatilized, turn on the printer.

08 TROUBLE SHOOTING GUIDE

1. The printer only delivers paper without printing contents.

- (1) Check if the print paper is reversely laid. If not, double click “On/Off button” to print the self-test page.
- (2) If the self-test page cannot be printed, the printer is malfunctioning. If the self-test page is correct, check the paper or APP.

2. Blurry printing

- (1) Check the print density whose default value is 3 for the best printing effect.
- (2) If the prints have a horizontal line or only some of contents can be printed, check if the print head is clogged and clean it with alcohol.
- (3) If the print quality is poor, please use NiiMbot paper range.

3 Paper feeding or printing job cannot be stopped until 200mm paper is delivered with the failure of paper positioning.

If no paper gap is detected after 200 mm paper is delivered, there are three possibilities as follows:

Please confirm the correct type of label is chosen in the App. The printer supports “Crack label” “Black mark label” and “Continuous label”.

2)When the cracking noise arises, the printer paper is used up. Please refill.

1) If neither of the above situations above happens, open the cover and close it before restarting. If the problem persists, the printer is malfunctioning.

A ‘Lack of paper’ error prompts.

(1) Check if the printer paper has been used up.

(2) If not, make sure if the cover is properly locked. (Loose cover may result either shifted printouts or failed paper detection.)

5 Unexpected stop while printing

In order to ensure the reliability of the printer, multiple protection orders are designed. The printer will stop working because of ‘Lack of paper’ , ‘Cover open’ , ‘Wrong data’ , ‘High temperature’ or ‘Low battery’ . Please analyze the problems according to the tips on the APP.

6 Printer freezing

If the printer freezes and it does not respond or cannot be shut down, please prod the reset hole with a thin stripe-shaped item (eg.clip) to shut down the printer. The printer usually can work after rebooting.

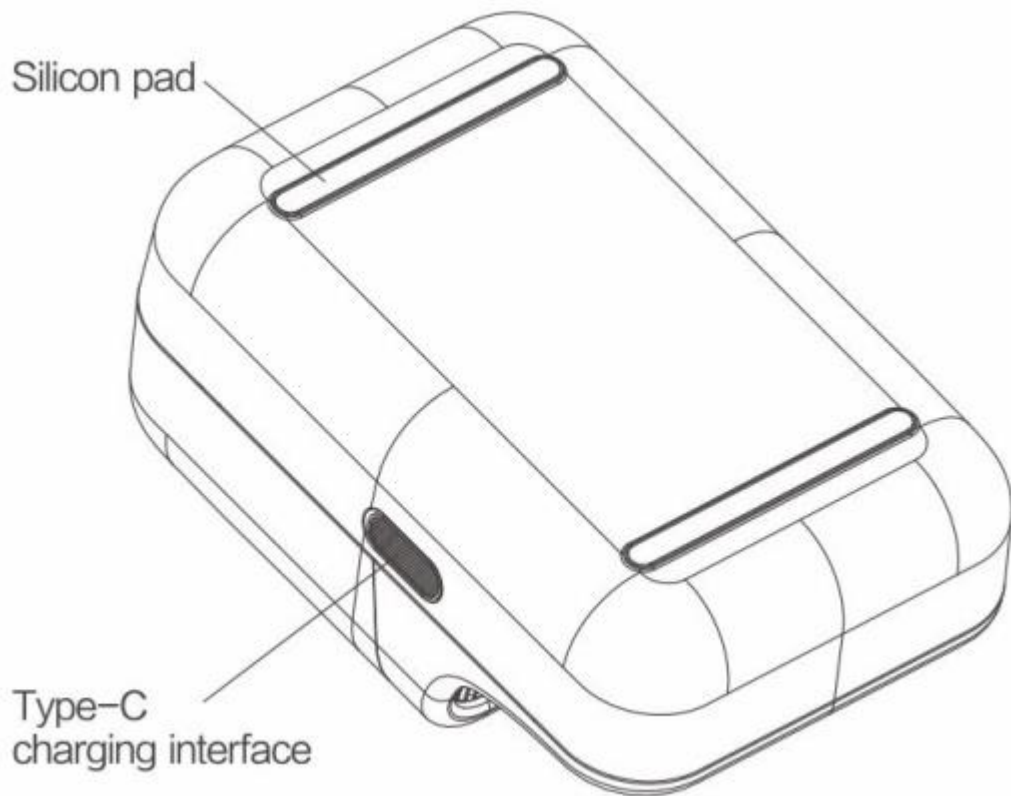

(1) Warnings

1. Power off the printer immediately when it malfunctions.
2. There are complex circuits and devices inside the printer, please do not disassemble it. Otherwise, short circuit or electrolyte penetration will be caused. If eyes contact with electrolyte accidentally, flush eye(s) with clean, flowing water and go to the hospital.
3. Charge the battery in a cool and airy place. Do not expose the printer and power adapter to high-temperature and high-humidity environments, or to water to avoid short circuits that can cause the battery to heat up, smoke, deform, damage, or even explode. If the power adapter comes into contact with water or other liquid, cut off the power immediately. When you notice smoke or an odor from the printer or power adapter, unplug the power adapter immediately to avoid burns.
4. Do not squeeze, mechanically vibrate, shake the printer or power adapter, remove or modify the power adapter. Moreover, do not use the power adapter in the event of damage to the power cable, as this may result in electric shock, fire and damage to the power adapter.

5. Do not use the printer where there are inflammable substances like gas stations and fuel warehouses.

Caution

1. Safely keep this product and its accessories away from children to prevent danger.
2. Do not disassemble the printer by yourself; do not open the cover during printing; after printing, the print head is still hot, do not touch it to avoid burns.
3. Charge the printer and power adapter in a well-ventilated place.
4. Please wipe the printer gently with a clean, soft cloth. Solutes, corrosive chemicals or detergents such as benzene or thinners are prohibited.
5. Both overtemperature and undertemperature environments can degrade the print quality.
6. Please charge the battery every three months if the printer is not used for long time. Otherwise, the battery will become useless and even cause battery leakage which results in the damage to the printer.
7. If the battery fails to meet the performance requirements, contact the after-sales service personnel.
8. Use NiiMbot original paper, otherwise, poor print quality or damage to the printer may happen.
9. The time of preservation of printouts is related to the quality of thermal paper. If long-term preservation of printouts is needed, please choose long-lasting thermal printer paper.

11Software download

Please download “Niimbot” App in App Store or Google Play to print the industrial labels.

(1) How to print

Open “Niimbot” app. Click “Unconnect” at the right top corner to connect the printer with phone via Bluetooth. You can either choose the industrial templates or customize your templates before clicking “printing”.

(2) Download through scanning the QR code.

Software download

Start a brand-new label printing experience in two steps

- 1.Download the APP
- 2.Open the lid and put in consumables

Method I: Download NIIMBOT APP by scanning the QR code

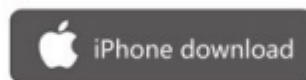

Method II: Search NIIMBOT in APP store/ Google Play



NiiMbot



(3)Please click “Tutorial” at the right top corner to watch the tutorial videos on printer functions.

Warranties

1. From the date of purchase, the print head of this printer is guaranteed for 3 months, other parts are guaranteed for 12 months.

2

3 Fees will apply outside the warranty period. In this case, if repair service is needed, please contact the after-sales service center for repair parts at additional costs.

4 Warranty services are not available during the warranty period if:

1.) Damage caused by accidents, overuse, misuse or use of other consumables instead of NiiMbot products.
2.) The printer has been disassembled, repaired or modified without authorization.
3.) Printing problems caused by scratches on the print head.
4.) The purchase record is inconsistent with the serial number of the printer under warranty.
5.) Damage caused by human or Force Majeure.

Manufacturer's Name: Wuhan Jingchen Intelligent Identification Technology Co., Ltd.

Sample Description: remembrance portable printer

Trade Mark: NIIMBOT

Model number: B21-C, B21-C2B, B21-C2W, B21-C2U, B21-D, B21-D2B, B21-D2W, B21-D2U, B21-A, B21-B

Operating Temperature: - 10° C to 40° C

This product is a fixed location. To comply with RF exposure requirements, a minimum separation distance of 20cm must be maintained between the user's

body and the device, including the antenna. Use only the supplied or an approved antenna.

This device in compliance with the essential requirements and other relevant provisions of Directive 2014/53/EU. All essential radio test suites have been carried out.

1. CAUTION : RISK OF EXPLOSION IF BATTERY IS REPLACED BY AN INCORRECT TYPE. DI
SPOSE OF

USED BATTERIES ACCORDING TO THE INSTRUCTIONS

2. The device complies with RF specifications when the device used at 20cm from your body

CE NB RF specification:

Function	Operation Frequency	Max RF Outputpower (dBm)	Limit (dBm)
BT	2402-2480MHz	6.00	20
BLE	2402-2480MHz	2.80	20
2.4G WiFi	2412-2472MHz	15.89	20
2.4G WiFi	2422-2462MHz	13.43	20

This device complies with part 15 of the FCC Rules. Operation is subject to the following two conditions: (1) this device may not cause harmful interference, and (2) this device must accept any interference received, including interference that may cause undesired operation.

Any changes or modifications not expressly approved by the party responsible for compliance could void the user's authority to operate the equipment.

NOTE: This equipment has been tested and found to comply with the limits for a Class B digital device, pursuant to Part 15 of the FCC Rules. These limits are designed to provide reasonable protection against harmful interference in a residential installation. This equipment generates, uses and can radiate radio frequency energy and, if not installed and used in accordance with the instructions, may cause harmful interference to radio communications. However, there is no guarantee that interference will not occur in a particular installation. If this equipment does cause harmful interference to radio or television reception, which can be determined by turning the equipment off and on, the user is encouraged to try to correct the interference by one or more of the following measures:

- Reorient or relocate the receiving antenna.
- Increase the separation between the equipment and receiver.
- Connect the equipment into an outlet on a circuit different from that to which the receiver is connected.
- Consult the dealer or an experienced radio/TV technician for help.

To maintain compliance with FCC's RF Exposure guidelines, This equipment should be installed and operated with minimum distance between 20cm the radiator your body: Use only the supplied antenna.

Warning: Changes or modifications to this unit not expressly approved by the part responsible for compliance could void the user's authority to operate the equipment

2. Any Changes or modifications not expressly approved by the party responsible for compliance could void the user's authority to operate the equipment

WARRANTY CARD
User name:
Telephone:
Purchase date:
Model:
Serial NO.:

Factory inspection:

Customer service: 400-991-8305