



TEST REPORT

For FCC Part15B

Report No.: **CHTEW22040207** Report verification: 

Project No.: **SHT2202009001EW**

FCC ID.....: **2ARTX-Z3**

Applicant's name.....: **LAVA International Limited**

Address.....: **A-56, Sector-64, Noida, Gautam Buddha Nagar, Uttar Pradesh, 201301**

Product Name: **Mobile phone**

Trade Mark: **LAVA**

Model No.: **Z3**

Listed Model(s): **-**

Standard: **47 CFR FCC Part 15 Subpart B**

Date of receipt of test sample.....: **Apr. 13, 2022**

Date of testing.....: **Apr. 14, 2022- May. 05, 2022**

Date of issue.....: **May. 06, 2022**

Result.....: **Pass**

Compiled by
 (position+printed name+signature)..: **File administrators Silvia Li**

Supervised by
 (position+printed name+signature)..: **Project Engineer Aaron Fang**

Approved by
 (position+printed name+signature)..: **RF Manager Hans Hu**

Silvia Li

Aaron.Fang

HansHu

Testing Laboratory Name: **Shenzhen Huatongwei International Inspection Co., Ltd.**

Address.....: **1/F, Bldg 3, Hongfa Hi-tech Industrial Park, Genyu Road, Tianliao, Gongming, Shenzhen, China**

Shenzhen Huatongwei International Inspection Co., Ltd. All rights reserved.

This publication may be reproduced in whole or in part for non-commercial purposes as long as the Shenzhen Huatongwei International Inspection Co., Ltd. is acknowledged as copyright owner and source of the material. Shenzhen Huatongwei International Inspection Co., Ltd. takes no responsibility for and will not assume liability for damages resulting from the reader's interpretation of the reproduced material due to its placement and context.

The test report merely corresponds to the test sample.

Contents

1.	<u>TEST STANDARDS AND REPORT VERSION</u>	<u>3</u>
1.1.	Test Standards	3
1.2.	Report version information	3
2.	<u>TEST DESCRIPTION</u>	<u>4</u>
3.	<u>SUMMARY.....</u>	<u>5</u>
3.1.	Client Information	5
3.2.	Product Description	5
3.3.	Testing Laboratory Information	5
4.	<u>TEST CONFIGURATION.....</u>	<u>6</u>
4.1.	Descriptions of test mode	6
4.2.	Configuration of Tested System	6
4.3.	Environmental conditions	6
4.4.	Statement of the measurement uncertainty	7
4.5.	Equipments Used during the Test	8
5.	<u>TEST CONDITIONS AND RESULTS</u>	<u>9</u>
5.1.	Conducted Emissions Test	9
5.2.	Radiated Emissions Test	12
6.	<u>TEST SETUP PHOTOS OF THE EUT</u>	<u>16</u>
7.	<u>EXTERNAL AND INTERNAL PHOTOS OF THE EUT</u>	<u>17</u>

1. TEST STANDARDS AND REPORT VERSION

1.1. Test Standards

The tests were performed according to following standards:

[47 CFR FCC Part 15 Subpart B](#) - Unintentional Radiators

[ANSI C63.4: 2014](#) – American National Standard for Methods of Measurement of Radio-Noise Emissions from Low-Voltage Electrical and Electronic Equipment in the Range of 9 kHz to 40GHz

1.2. Report version information

Revision No.	Date of issue	Description
N/A	2022-05-06	Original

2. TEST DESCRIPTION

Section	Test Item	Section in CFR 47	Result #1	Test Engineer
5.1	Conducted Emissions	15.107(a)	PASS	Pan Xie
5.2	Radiated Emissions	15.109(a)	PASS	Pan Xie

Note:

#1: The test result does not include measurement uncertainty value

3. SUMMARY

3.1. Client Information

Applicant:	LAVA International Limited
Address:	A-56, Sector-64, Noida, Gautam Buddha Nagar, Uttar Pradesh, 201301
Manufacturer:	LAVA INTERNATIONAL LIMITED
Address:	A-154 D, Sector-63, Noida, Gautam Buddha Nagar, Uttar Pradesh, 201301

3.2. Product Description

Main unit information:	
Product Name:	Mobile phone
Trade Mark:	LAVA
Model No.:	Z3
Listed Model(s):	-
Power supply:	DC 3.85V from Battery
Hardware version:	LAVA_LZG403_25L_V2.0
Software version:	LAVA_LZG403_25L_SW_V01
Accessory unit information:	
Battery information:	3.85Vdc, 4920mAh
Adapter information:	Model:TOP-804-050200 Input: AC100-240V, 50/60Hz, 0.3A Output: 5.0Vdc, 2000mA

3.3. Testing Laboratory Information

Laboratory Name	Shenzhen Huatongwei International Inspection Co., Ltd.	
Laboratory Location	1/F, Bldg 3, Hongfa Hi-tech Industrial Park, Genyu Road, Tianliao, Gongming, Shenzhen, China	
Connect information:	Tel: 86-755-26715499 E-mail: cs@szhtw.com.cn http://www.szhtw.com.cn	
Qualifications	Type	Accreditation Number
	FCC	762235

4. TEST CONFIGURATION

4.1. Descriptions of test mode

Test mode	Description
Camera recording	Keep the EUT in Camera recording status
Video Playing	Keep the EUT in Video Playing status
Data exchange	Keep the EUT in Data exchange with PC status

Pre-scan above all test mode, found below test mode which it was worse case mode, so only show the test data for worse case mode on the test report

Test Item	Test mode for worse case
Conducted Emissions	Camera recording
Radiated Emissions	Camera recording

4.2. Configuration of Tested System

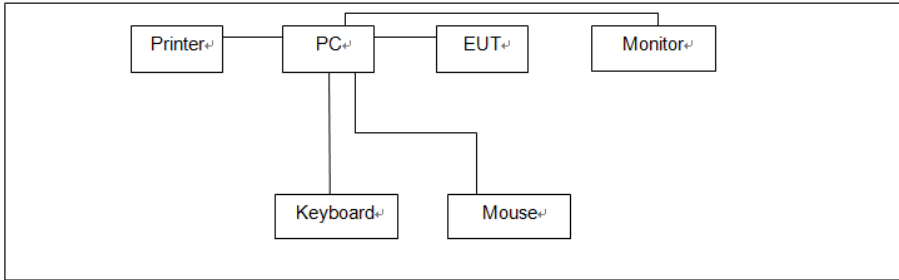
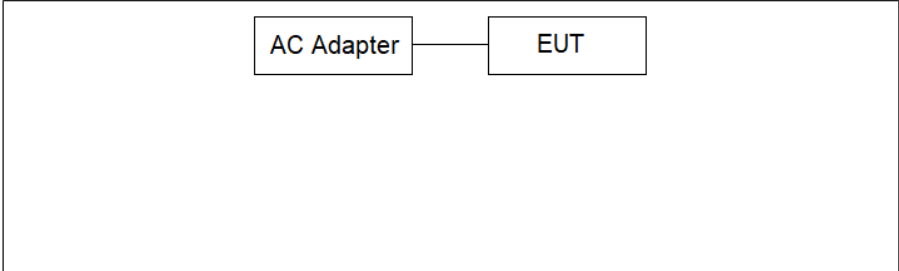
Test mode	Configuration
Data exchange mode	 <pre> graph TD PC[PC] --- Printer[Printer] PC --- EUT[EUT] PC --- Monitor[Monitor] PC --- Keyboard[Keyboard] PC --- Mouse[Mouse] </pre>
Other modes	 <pre> graph LR AC[AC Adapter] --- EUT[EUT] </pre>

4.3. Environmental conditions

During the measurement the environmental conditions were within the listed ranges:

Temperature:	15~35°C
Relative Humidity:	30~60 %
Air Pressure:	950~1050mba

4.4. Statement of the measurement uncertainty

Test Items	MeasurementUncertainty
Conducted emission	3.25dB
Radiated emission	<1GHz: 4.22dB >1GHz:5.06ppm

This uncertainty represents an expanded uncertainty expressed at approximately the 95% confidence level using a coverage factor of $k=1.96$.

4.5. Equipments Used during the Test

● Conducted Emission							
Used	Test Equipment	Manufacturer	Equipment No.	Model No.	Serial No.	Last Cal. Date (YY-MM-DD)	Next Cal. Date (YY-MM-DD)
●	Shielded Room	Albatross projects	HTWE0114	N/A	N/A	2018/09/28	2023/09/27
●	EMI Test Receiver	R&S	HTWE0111	ESCI	101247	2021/09/14	2022/09/13
●	Artificial Mains	SCHWARZBECK	HTWE0113	NNLK 8121	573	2021/09/17	2022/09/16
●	Pulse Limiter	R&S	HTWE0033	ESH3-Z2	100499	2021/09/16	2022/09/15
●	RF Connection Cable	HUBER+SUHNER	HTWE0113-02	ENVIROFLEX_142	EF-NM-BNCM-2M	2021/09/17	2022/09/16
●	Test Software	R&S	N/A	ES-K1	N/A	N/A	N/A

● Radiated Emission-6th test site							
Used	Test Equipment	Manufacturer	Equipment No.	Model No.	Serial No.	Last Cal. Date (YY-MM-DD)	Next Cal. Date (YY-MM-DD)
●	Semi-Anechoic Chamber	Albatross projects	HTWE0127	SAC-3m-02	C11121	2018/09/30	2022/09/29
●	EMI Test Receiver	R&S	HTWE0099	ESCI	100900	2021/09/14	2022/09/13
●	Ultra-Broadband Antenna	SCHWARZBECK	HTWE0119	VULB9163	546	2020/04/28	2023/04/27
●	Pre-Amplifier	SCHWARZBECK	HTWE0295	BBV 9742	N/A	2021/11/05	2022/11/04
●	RF Connection Cable	HUBER+SUHNER	HTWE0062-01	N/A	N/A	2022/02/25	2023/02/24
●	RF Connection Cable	HUBER+SUHNER	HTWE0062-02	SUCOFLEX104	501184/4	2022/02/25	2023/02/24
●	Test Software	R&S	N/A	ES-K1	N/A	N/A	N/A

● Radiated emission-7th test site							
Used	Test Equipment	Manufacturer	Equipment No.	Model No.	Serial No.	Last Cal. Date (YY-MM-DD)	Next Cal. Date (YY-MM-DD)
●	Semi-Anechoic Chamber	Albatross projects	HTWE0122	SAC-3m-01	N/A	2018/09/27	2022/09/26
●	Spectrum Analyzer	R&S	HTWE0098	FSP40	100597	2021/09/13	2022/09/12
●	Horn Antenna	SCHWARZBECK	HTWE0126	9120D	1011	2020/04/01	2023/03/31
●	Broadband Pre-amplifier	SCHWARZBECK	HTWE0201	BBV 9718	9718-248	2022/02/28	2023/02/27
●	RF Connection Cable	HUBER+SUHNER	HTWE0121-01	RE-7-FH	N/A	2022/03/04	2023/03/03
●	Test Software	Audix	N/A	E3	N/A	N/A	N/A

5. TEST CONDITIONS AND RESULTS

5.1. Conducted Emissions Test

LIMIT

FCC CFR Title 47 Part 15 Subpart B Section 15.107:

Frequency range (MHz)	Limit (dBuV)	
	Quasi-peak	Average
0.15-0.5	66 to 56*	56 to 46*
0.5-5	56	46
5-30	60	50

* Decreases with the logarithm of the frequency.

TEST CONFIGURATION

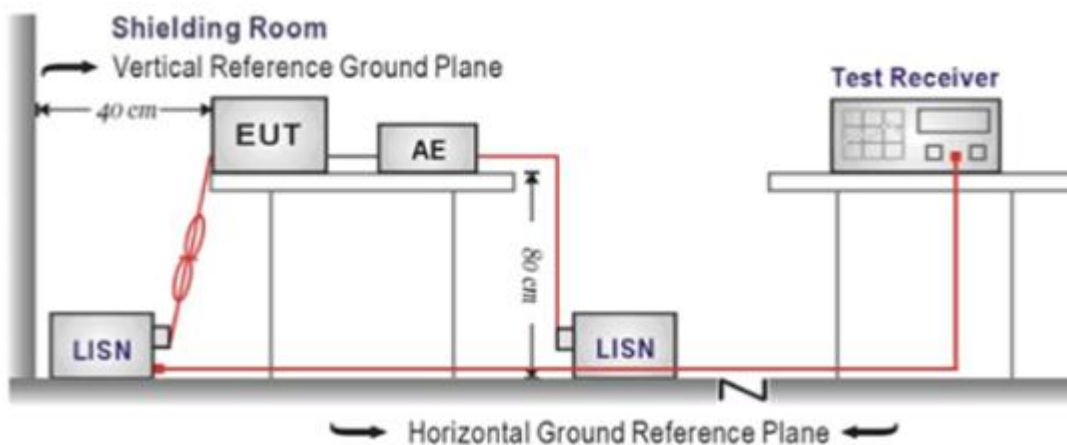

TEST PROCEDURE

1. The EUT was setup according to ANSI C63.4:2014
2. The EUT was placed on a platform of nominal size, 1 m by 1.5 m, raised 80 cm above the conducting ground plane. The vertical conducting plane was located 40 cm to the rear of the EUT. All other surfaces of EUT were at least 80 cm from any other grounded conducting surface.
3. The EUT and simulators are connected to the main power through a line impedance stabilization network (LISN). The LISN provides a 50ohm / 50uH coupling impedance for the measuring equipment.
4. The peripheral devices are also connected to the main power through a LISN. (Please refer to the block diagram of the test setup and photographs)
5. Each current-carrying conductor of the EUT power cord, except the ground (safety) conductor, was individually connected through a LISN to the input power source.
6. The excess length of the power cord between the EUT and the LISN receptacle were folded back and forth at the center of the lead to form a bundle not exceeding 40 cm in length.
7. Conducted emissions were investigated over the frequency range from 0.15MHz to 30MHz using a receiver bandwidth of 9 kHz.
8. During the above scans, the emissions were maximized by cable manipulation.

TEST MODE:

Please refer to the clause 3.3

TEST RESULTS

Passed Not Applicable

Test Line:

L

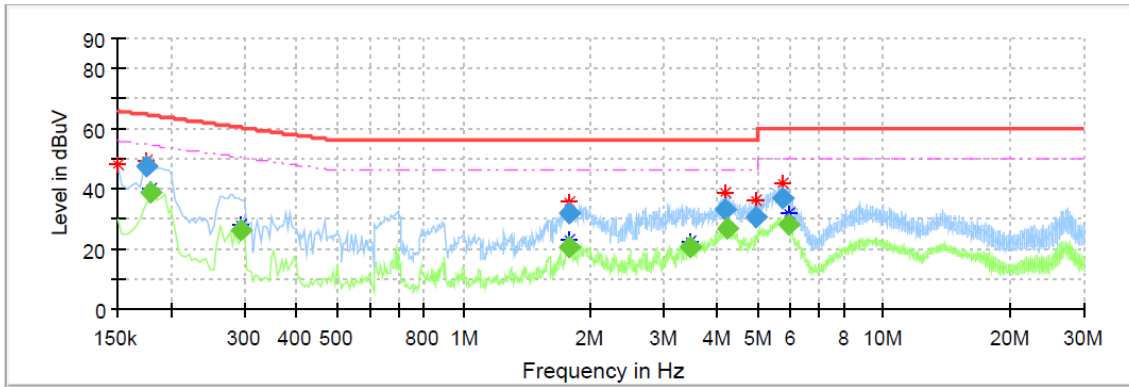

Frequency (MHz)	QuasiPeak (dBuV)	CAverage (dBuV)	Limit (dBuV)	Margin (dB)	Line	Corr. (dB)
0.175500	47.24	---	64.70	17.46	L1	10.1
0.179500	---	38.85	54.51	15.66	L1	10.1
0.295500	---	25.98	50.37	24.39	L1	10.1
1.791500	31.68	---	56.00	24.32	L1	10.1
1.791500	---	20.75	46.00	25.25	L1	10.1
3.459500	---	20.82	46.00	25.18	L1	10.3
4.199500	33.26	---	56.00	22.74	L1	10.3
4.243500	---	26.80	46.00	19.20	L1	10.3
4.975500	30.71	---	56.00	25.29	L1	10.3
5.711500	36.99	---	60.00	23.01	L1	10.3
5.967500	---	27.82	50.00	22.18	L1	10.3

Test Line:

N

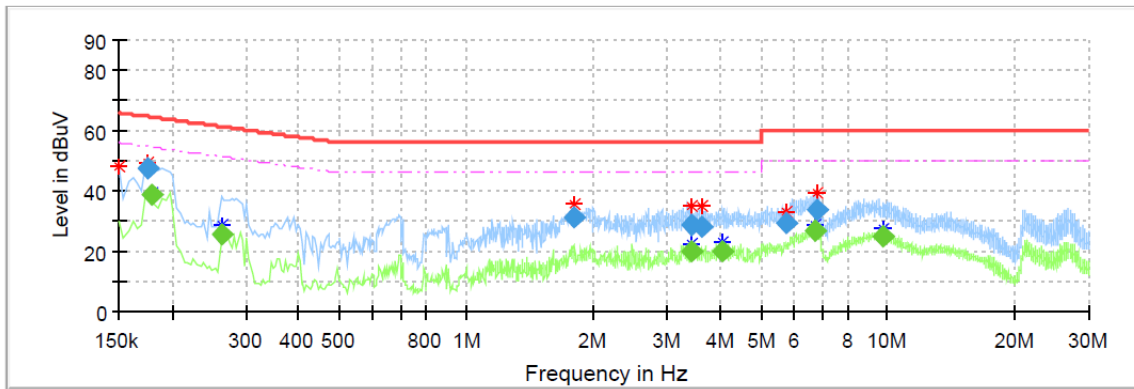

Frequency (MHz)	QuasiPeak (dBuV)	CAverage (dBuV)	Limit (dBuV)	Margin (dB)	Line	Corr. (dB)
0.175500	47.20	---	64.70	17.49	N1	10.1
0.179500	---	38.84	54.51	15.67	N1	10.1
0.263500	---	25.82	51.32	25.50	N1	10.1
1.795500	31.53	---	56.00	24.47	N1	10.1
3.403500	28.62	---	56.00	27.38	N1	10.3
3.411500	---	20.21	46.00	25.79	N1	10.3
3.615500	28.11	---	56.00	27.89	N1	10.3
4.063500	---	19.77	46.00	26.23	N1	10.3
5.759500	29.07	---	60.00	30.93	N1	10.3
6.691500	---	27.15	50.00	22.85	N1	10.4
6.759500	34.03	---	60.00	25.97	N1	10.4
9.719500	---	25.01	50.00	24.99	N1	10.5

5.2. Radiated Emissions Test

LIMIT

FCC CFR Title 47 Part 15 Subpart B Section 15.109

Frequency	Limit (dBuV/m @3m)	Value
30MHz-88MHz	40.00	Quasi-peak
88MHz-216MHz	43.50	Quasi-peak
216MHz-960MHz	46.00	Quasi-peak
960MHz-1GHz	54.00	Quasi-peak
Above 1GHz	54.00	Average
	74.00	Peak

TEST CONFIGURATION

➤ 30MHz ~ 1GHz

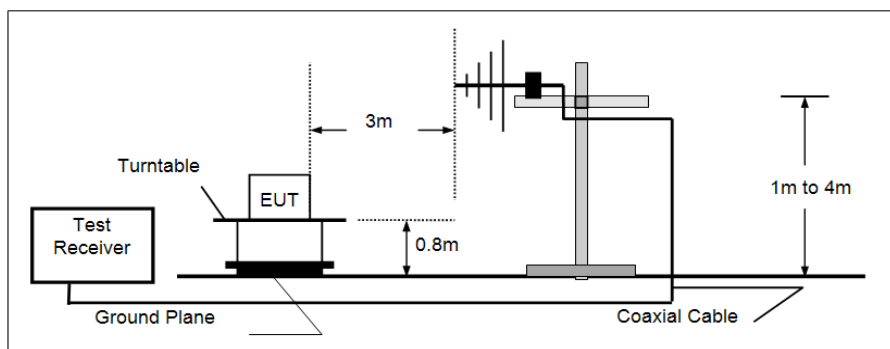

➤ Above 1GHz

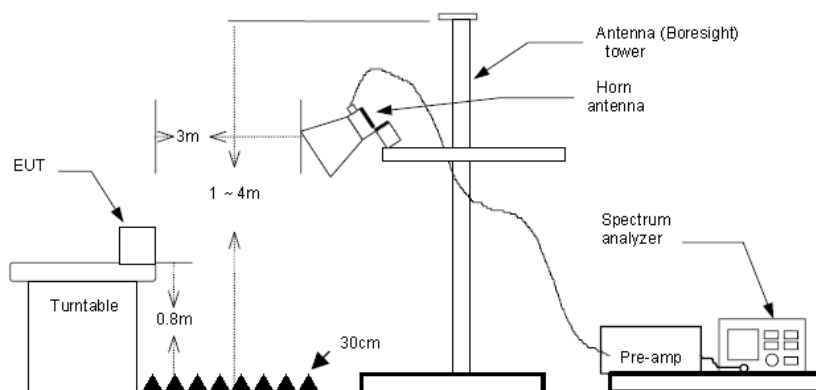

TEST PROCEDURE

1. The EUT was tested according to ANSI C63.4:2014.
2. The EUT is placed on a turn table which is 0.8 meter above ground.
3. The turn table is rotated 360 degrees to determine the position of the maximum emission level.
4. The EUT was positioned such that the distance from antenna to the EUT was 3 meters.
5. The antenna is scanned from 1 meter to 4 meters to find out the maximum emission level. This is repeated for both horizontal and vertical polarization of the antenna.
6. Use the following spectrum analyzer settings
 - (1) Span shall wide enough to fully capture the emission being measured;
 - (2) Below 1GHz,
RBW=120KHz, VBW=300KHz, Sweep=auto, Detector function=peak, Trace=max hold;
If the emission level of the EUT measured by the peak detector is 3 dB lower than the applicable limit, the peak emission level will be reported. Otherwise, the emission measurement will be repeated using the quasi-peak detector and reported.
 - (3) From 1GHz to 5th harmonic, RBW=1MHz, VBW=3MHz

TEST MODE:

Please refer to the clause 3.3

TEST RESULTS

Passed **Not Applicable**

Note: Final Level = Receiver Read level + Antenna Factor + Cable Loss – Preamplifier Factor
The emission levels of frequency above 6GHz are very lower than limit and not show in test report.

Polarization:

Horizontal

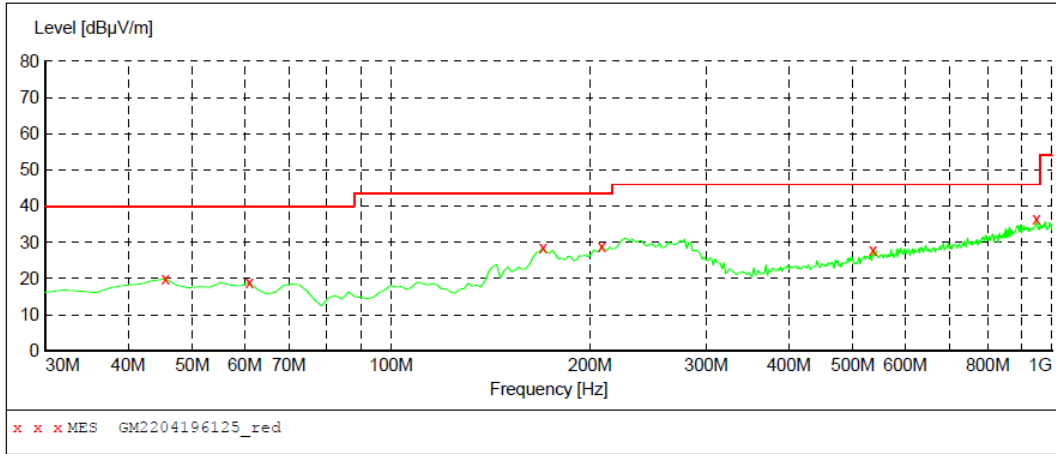

MEASUREMENT RESULT: "GM2204196125_red"

4/19/2022 11:57PM

Frequency MHz	Level dBuV/m	Transd dB	Limit dBuV/m	Margin dB	Det.	Height cm	Azimuth deg	Polarization
45.520000	19.90	-9.4	40.0	20.1	QP	100.0	63.00	HORIZONTAL
61.040000	18.90	-10.3	40.0	21.1	QP	100.0	145.00	HORIZONTAL
169.680000	28.40	-13.2	43.5	15.1	QP	100.0	84.00	HORIZONTAL
208.480000	29.00	-10.0	43.5	14.5	QP	100.0	84.00	HORIZONTAL
536.340000	27.90	-0.5	46.0	18.1	QP	100.0	271.00	HORIZONTAL
947.620000	36.60	7.6	46.0	9.4	QP	100.0	154.00	HORIZONTAL

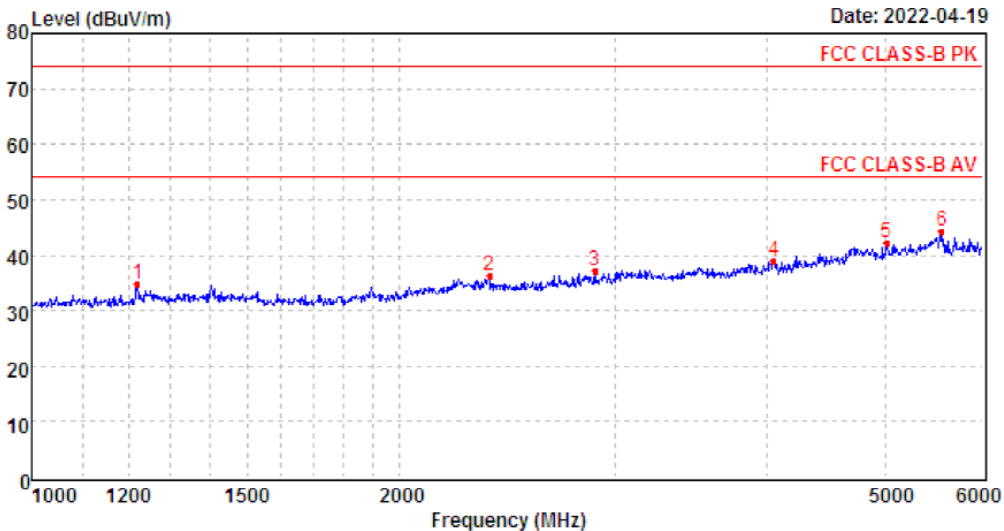

Mark	Frequency MHz	Reading dBuV/m	Antenna dB	Cable dB	Preamp dB	Level dBuV/m	Limit dBuV/m	Over limit	Remark
1	1220.04	41.84	25.72	3.90	36.78	34.68	74.00	-39.32	Peak
2	2367.50	40.16	27.76	5.50	37.25	36.17	74.00	-37.83	Peak
3	2888.46	39.90	28.60	6.12	37.47	37.15	74.00	-36.85	Peak
4	4045.37	38.11	29.99	7.42	36.48	39.04	74.00	-34.96	Peak
5	5006.77	36.19	31.94	8.82	34.83	42.12	74.00	-31.88	Peak
6	5555.09	35.90	31.81	9.39	32.81	44.29	74.00	-29.71	Peak

Polarization:

Vertical

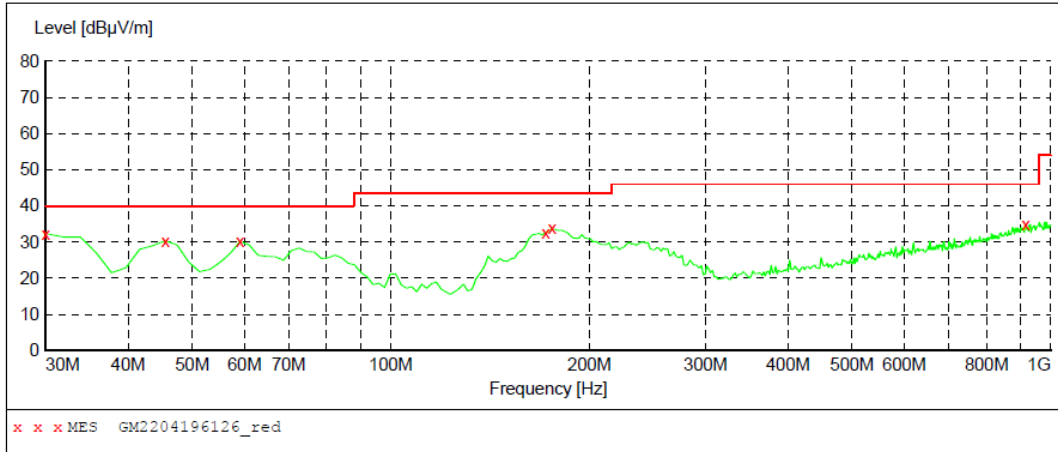

MEASUREMENT RESULT: "GM2204196126_red"

4/20/2022 12:00AM

Frequency MHz	Level dBuV/m	Transd dB	Limit dBuV/m	Margin dB	Det.	Height cm	Azimuth deg	Polarization
30.000000	32.30	-12.7	40.0	7.7	QP	100.0	211.00	VERTICAL
45.520000	30.30	-9.4	40.0	9.7	QP	100.0	271.00	VERTICAL
59.100000	30.10	-9.9	40.0	9.9	QP	100.0	293.00	VERTICAL
171.620000	32.60	-13.0	43.5	10.9	QP	100.0	84.00	VERTICAL
175.500000	33.70	-12.7	43.5	9.8	QP	100.0	84.00	VERTICAL
916.580000	34.80	7.1	46.0	11.2	QP	100.0	211.00	VERTICAL

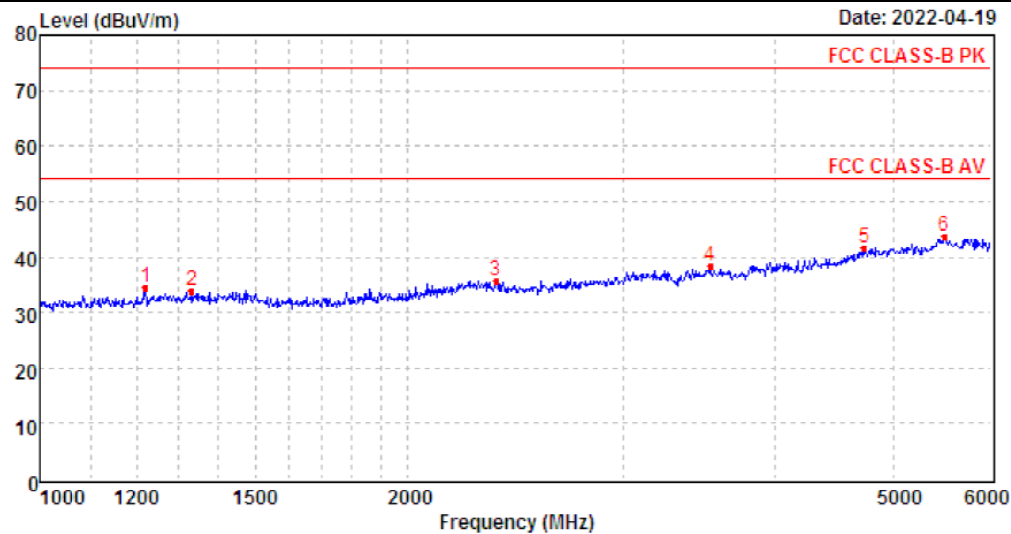

Mark	Frequency MHz	Reading dBuV/m	Antenna dB	Cable dB	Preamp dB	Level dBuV/m	Limit dBuV/m	Over limit	Remark
1	1220.04	41.71	25.72	3.90	36.78	34.55	74.00	-39.45	Peak
2	1332.00	40.10	26.19	4.08	36.34	34.03	74.00	-39.97	Peak
3	2363.27	39.81	27.77	5.49	37.27	35.80	74.00	-38.20	Peak
4	3536.69	39.46	29.25	6.83	37.03	38.51	74.00	-35.49	Peak
5	4727.78	36.52	31.40	8.26	34.42	41.76	74.00	-32.24	Peak
6	5495.69	34.85	31.88	9.34	32.40	43.67	74.00	-30.33	Peak

6. TEST SETUP PHOTOS OF THE EUT

Conducted Emissions (AC Mains)



Radiated Emissions (30MHz-1GHz)



Radiated Emissions (Above 1GHz)

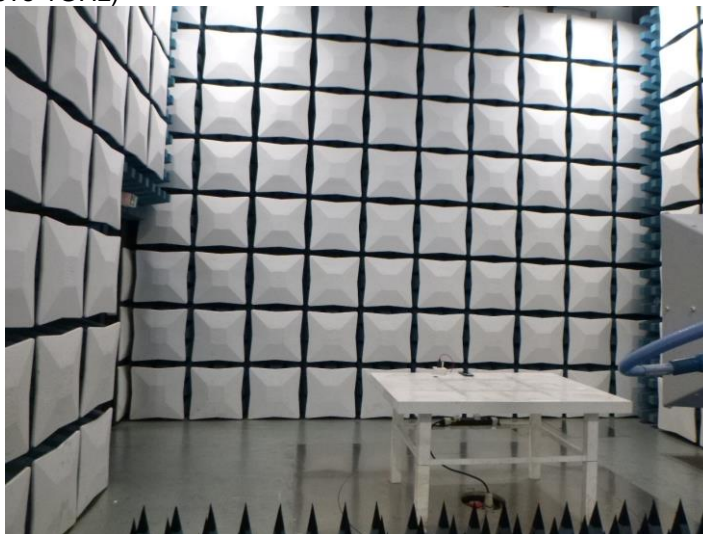

7. EXTERNAL AND INTERNAL PHOTOS OF THE EUT

Refer to the test report No.: CHTEW22040199

-----End of Report-----