

Delta Electronics, Inc.

TEST REPORT

REPORT NUMBER

190900036TWN-001

ISSUE DATE

Sep. 18, 2019

PAGES

50

DOCUMENT CONTROL NUMBER

© 2019 INTERTEK



Radio Spectrum TEST REPORT

Applicant:	Delta Electronics, Inc. No.39, Sec. 2, Huandong Rd., Shanhua Dist., Tainan City 741, Taiwan
Product:	Wi-Fi module
Model No.:	RS9113-N00-S1C
Brand Name:	REDPINE SIGNALS
FCC ID:	2ARTO-N00-S1C-1
Test Method/ Standard:	47 CFR FCC Part 15.247 & ANSI C63.10 2013 KDB 558074 D01 v04
Test By:	Intertek Testing Services Taiwan Ltd., Hsinchu Laboratory No. 11, Lane 275, Ko-Nan 1 Street, Chia-Tung Li, Shiang-Shan District, Hsinchu City, Taiwan



Prepared and Checked by:



John Cheng
Engineer

Approved by:



Durant Wei
Engineer

This report is for the exclusive use of Intertek's Client and is provided pursuant to the agreement between Intertek and its Client. Intertek's responsibility and liability are limited to the terms and conditions of the agreement. Intertek assumes no liability to any party, other than to the Client in accordance with the agreement, for any loss, expense or damage occasioned by the use of this report. Only the Client is authorized to permit copying or distribution of this report and then only in its entirety. Any use of the Intertek name or one of its marks for the sale or advertisement of the tested material, product or service must first be approved in writing by Intertek. The observations and test results in this report are relevant only to the sample tested. This report by itself does not imply that the material, product, or service is or has ever been under an Intertek certification program.

Revision History

Report No.	Issue Date	Revision Summary
190900036TWN-001	Sep. 18, 2019	Original report

Table of Contents

Summary of Test Data	5
1. General Information	6
1.1 Identification of the EUT	6
1.2 Antenna description	6
1.3 Operation mode	7
1.4 Power setting.....	8
1.5 Peripherals equipment	8
2. Minimum 6 dB Bandwidth	9
2.1 Instrument Setting.....	9
2.2 Test Procedure	9
2.3 Test Diagram	9
2.4 Limit	9
2.5 Operating Environment Condition	9
2.6 Test Results	10
3. Maximum Peak Conducted Output Power	14
3.1 Instrument Setting.....	14
3.2 Test Procedure	14
3.3 Test Diagram	14
3.4 Limit	14
3.5 Operating Environment Condition	14
3.6 Test Results	15
4. Power Spectral Density.....	16
4.1 Instrument Setting.....	16
4.2 Test Procedure	16
4.3 Test Diagram	16
4.4 Limit	16
4.5 Operating Environment Condition	16
4.6 Test Results	17
5. Emissions in Non-Restricted Frequency Bands	21
5.1 Instruments Setting	21
5.2 Test Procedure	21
5.3 Test Diagram	21
5.4 Limit	21
5.5 Operating Environment Condition	21
5.6 Test Results	22
6. Emissions in Restricted Frequency Bands (Radiated emission measurements)	28
6.1 Instrument Setting.....	28
6.2 Test Procedure	28
6.3 Test Diagram	29

6.3.1 Radiated emission from 9kHz to 30MHz uses Loop Antenna:	29
6.3.2 Radiated emission below 1GHz using Bilog Antenna	29
6.3.3 Radiated emission above 1GHz using Horn Antenna	30
6.4 Limit	30
6.5 Operating Environment Condition	30
6.6 Test Result.....	31
7. Emission on Band Edge.....	36
7.1 Instrument Setting.....	36
7.2 Test Procedure	36
7.3 Operating Environment Condition	36
7.4 Test Results	37
8. AC Power Line Conducted Emission	44
8.1 Measuring instrument setting.....	44
8.2 Test Procedure	44
8.3 Test Diagram	44
8.4 Limit.....	45
8.5 Operating Environment Condition	45
8.6 Test Results	46
Appendix A: Test equipment list.....	48
Appendix B: Measurement Uncertainty	50

Summary of Test Data

Test Requirement	Applicable Rule (Section 15.247)	Result
Minimum 6 dB Bandwidth	15.247(a)(2)	Pass
Maximum Peak Conducted Output Power	15.247(b)(3)	Pass
Power Spectral Density	15.247(e)	Pass
Emissions In Non-Restricted Frequency Bands	15.247(d)	Pass
Emissions In Restricted Frequency Bands (Radiated emission measurements)	15.247(d), 15.205, 15.209	Pass
Emission On The Band Edge	15.247(d), 15.205	Pass
AC Power Line Conducted Emission	15.207	Pass
Antenna Requirement	15.203	Pass

1. General Information

1.1 Identification of the EUT

Product:	Wi-Fi module
Model No.:	RS9113-N00-S1C
Operating Frequency:	2412 MHz ~ 2462 MHz for 802.11b, 802.11g, 802.11n HT20
Channel Number:	11 channels for 2412 MHz ~ 2462 MHz
Frequency of Each Channel:	2412+5 k, k=0 ~ 10 for 802.11b, 802.11g, 802.11n HT20
Access scheme:	DSSS, OFDM
Rated Power:	DC 3.3V
Power Cord:	N/A
Sample receiving date:	Aug. 23, 2019
Sample condition:	Workable
Test Date(s):	Aug. 28, 2019 ~ Sep. 09, 2019

1.2 Antenna description

Antenna Gain : 3.86 dBi
Antenna Type : Dipole antenna
Connector Type : R SMA

1.3 Operation mode

- (1) TX mode: EUT use 「 QCOM_V1.0 」 entering test mode , and Touchscreen to change different channel.
- (2) With individual verifying, the maximum output power were found out 1 Mbps data rate for 802.11b mode, 6 Mbps data rate for 802.11g mode, 13 Mbps data rate for 802.11n(HT20) mode, the final tests were executed under these conditions recorded in this report individually.

802.11b ch6 chain0		802.11g ch6 chain0		802.11n(HT20) ch6 chain0	
Data rate (Mbps)	AV (dBm)	Data rate (Mbps)	AV (dBm)	Data rate (Mbps)	AV (dBm)
1	13.09	6	6.66	6.5	8.24
2	13.02	9	6.61	13	8.20
5.5	12.97	12	6.55	19.5	8.14
11	12.93	18	6.50	26	8.11
		24	6.47	39	8.06
		36	6.43	52	8.02
		48	6.39	58.5	7.99
		54	6.32	65	7.95

The signal is maximized through rotation and placement in the three orthogonal axes.

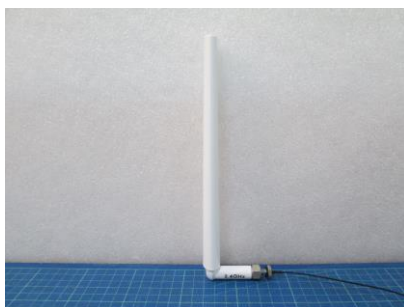

X axis



Y axis

After verifying three axes, we found the maximum electromagnetic field was occurred at X axis. The final test data was executed under this configuration.

1.4 Power setting

Mode	Channel	Frequency (MHz)	Power setting
802.11b	1	2412	18
	6	2437	18
	11	2462	18
802.11g	1	2412	11
	6	2437	11
	11	2462	11
802.11n (HT20)	1	2412	10
	6	2437	10
	11	2462	10

1.5 Peripherals equipment

Peripherals	Brand	Model No.	Serial No.	Data cable
Notebook PC	HP	HP Probook 440 G3	N/A	Other Mini USB 1 meter × 1
DC Power Supply	Twintex	TP-1603C	N/A	N/A

2. Minimum 6 dB Bandwidth

2.1 Instrument Setting

Spectrum Parameter	Setting
Detector	Peak
RBW	100kHz
VBW	$\geq 3 \times \text{RBW}$
Sweep	Auto couple
Trace	Allow the trace to stabilize.
Span	Between two times and five times the occupied bandwidth
Attenuation	Auto

2.2 Test Procedure

Step 1	The transmitter output was connected to the spectrum analyzer.
Step 2	Test was performed in accordance with clause 8.1 option1 of KDB 558074 D01.
Step 3	Measure the maximum width of the emission that is constrained by the frequencies associated with the two outermost amplitude points (upper and lower frequencies) that are attenuated by 6 dB relative to the maximum level measured in the fundamental emission

2.3 Test Diagram

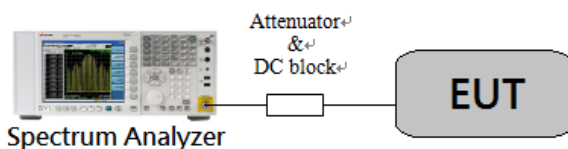

2.4 Limit

The minimum 6 dB bandwidth shall be at least 500 kHz.

2.5 Operating Environment Condition

Temperature (°C) :	26
Relative Humidity (%) :	56
Test Date :	2019/9/9

2.6 Test Results

Chain 0

Mode	Channel	Frequency (MHz)	6dB Bandwidth (MHz)	Limit (MHz)	Test Result
802.11b	1	2412	9.588	>0.5	Pass
	6	2437	10.011	>0.5	Pass
	11	2462	9.128	>0.5	Pass
802.11g	1	2412	16.538	>0.5	Pass
	6	2437	16.525	>0.5	Pass
	11	2462	16.553	>0.5	Pass
802.11n (HT20)	1	2412	17.749	>0.5	Pass
	6	2437	17.773	>0.5	Pass
	11	2462	17.744	>0.5	Pass

Chain0: 6dB Bandwidth @ 802.11b Mode Ch 1

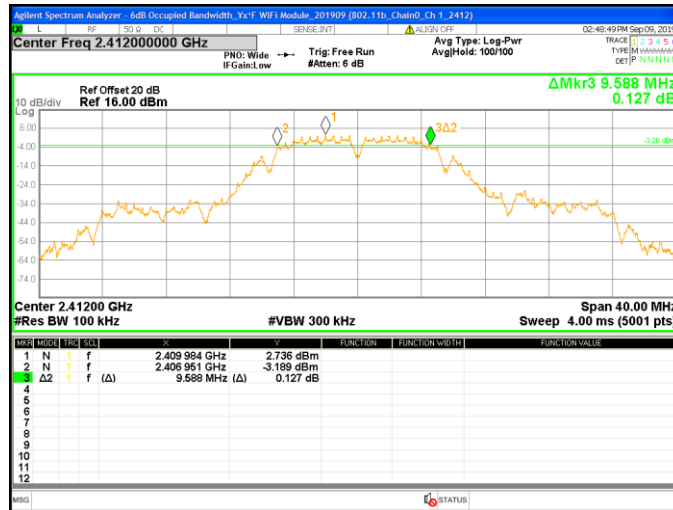

Chain0: 6dB Bandwidth @ 802.11b Mode Ch 6

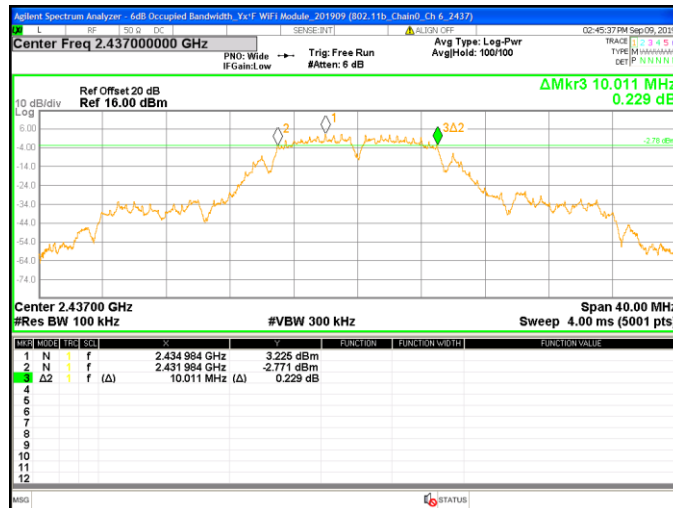

Chain0: 6dB Bandwidth @ 802.11b Mode Ch11

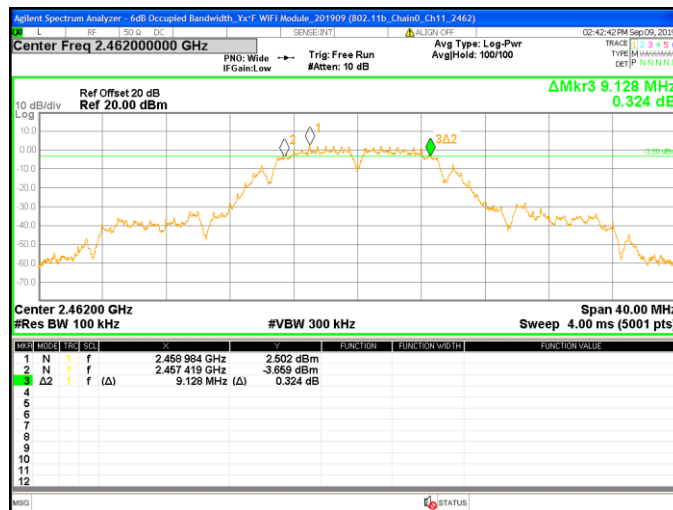

Chain0: 6dB Bandwidth @ 802.11g Mode Ch 1

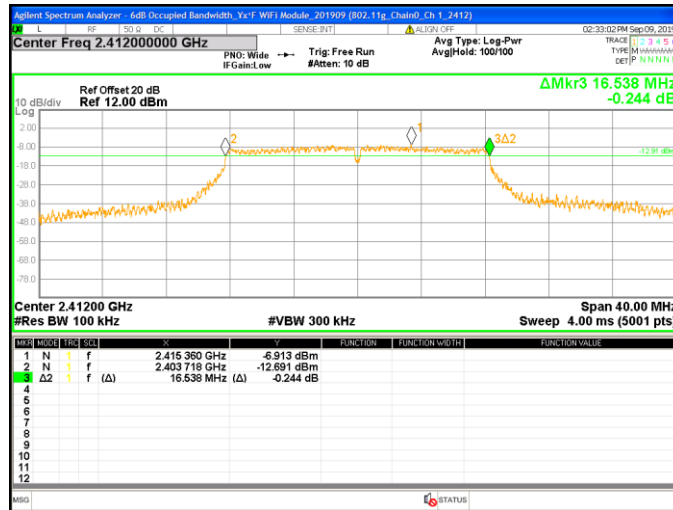

Chain0: 6dB Bandwidth @ 802.11g Mode Ch 6

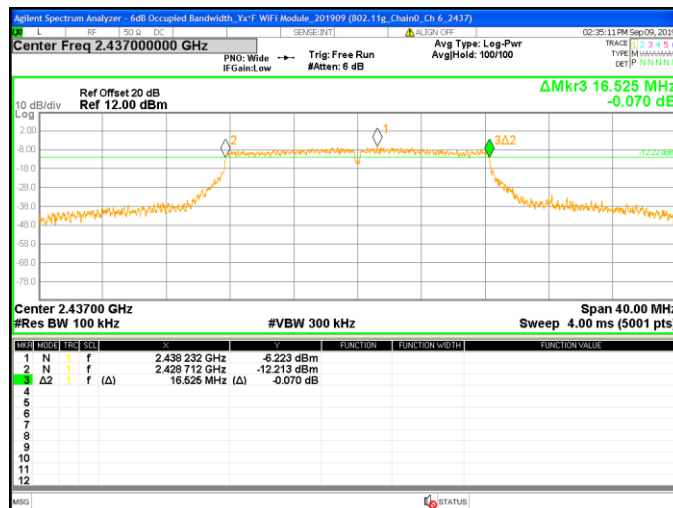

Chain0: 6dB Bandwidth @ 802.11g Mode Ch11

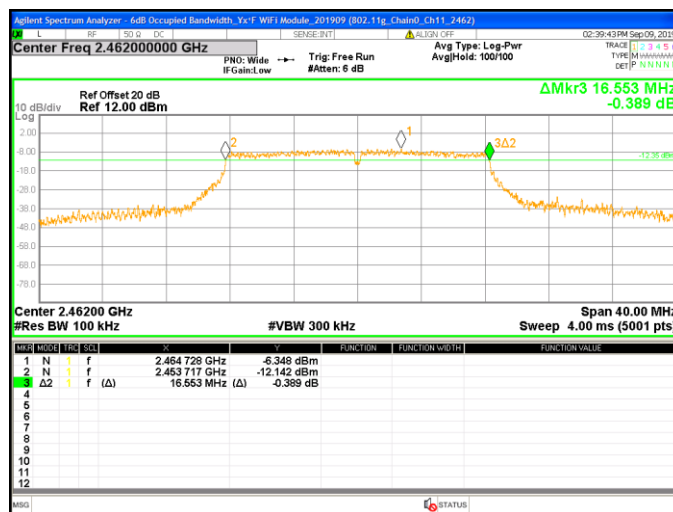

Chain0: 6dB Bandwidth @ 802.11n(HT20) Mode Ch 1

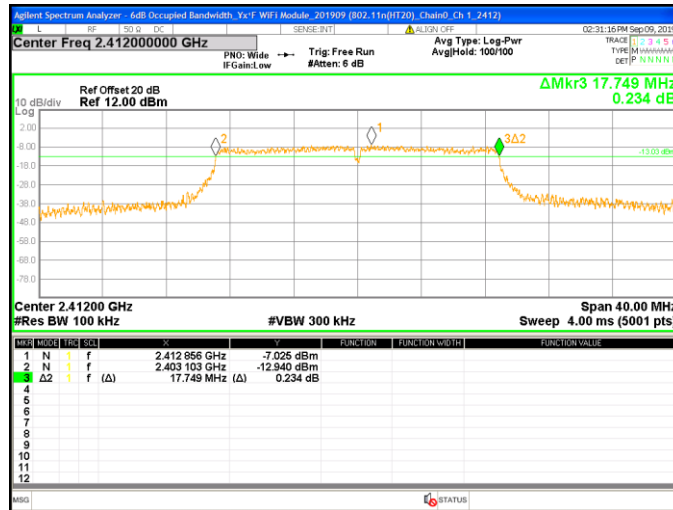

Chain0: 6dB Bandwidth @ 802.11n(HT20) Mode Ch 6

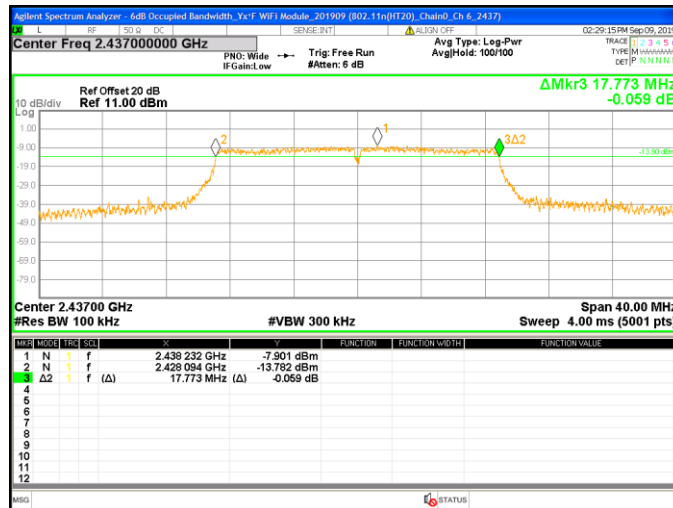

Chain0: 6dB Bandwidth @ 802.11n(HT20) Mode Ch11

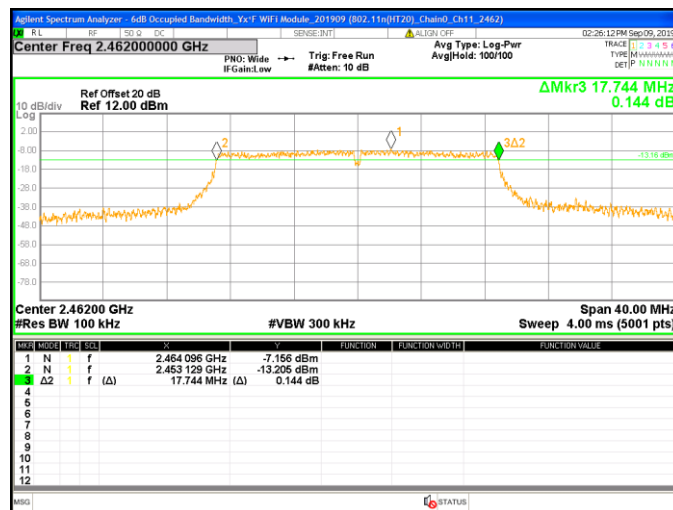

3. Maximum Peak Conducted Output Power

3.1 Instrument Setting

Power Meter Parameter	Setting
Bandwidth	65MHz bandwidth is greater than the EUT emission bandwidth
Detector	Peak & Average

3.2 Test Procedure

Test procedures refer to clause 9.1.3 peak power meter method and clause 9.2.3.2 measurement using a gated RF average power meter of KDB 558074 D01.

3.3 Test Diagram

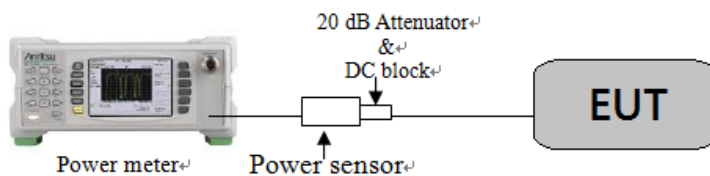

3.4 Limit

For systems using digital modulation in the 2400-2483.5 MHz: 1 Watt (30dBm)

3.5 Operating Environment Condition

Temperature (°C) :	26
Relative Humidity (%) :	56
Test Date :	2019/9/9

3.6 Test Results

Single Tx

Mode	Channel	Frequency (MHz)	Output Power (AV) (dBm)	Total Power (AV) (mW)	Maximum power (PK) (dBm)	Maximum power (PK) (mW)	Limit (dBm)	Margin (dB)
802.11b	1	2412	12.98	19.86	16.28	42.46	30	-13.72
	6	2437	13.09	20.37	16.44	44.06	30	-13.56
	11	2462	13.34	21.58	16.70	46.77	30	-13.30
802.11g	1	2412	6.47	4.44	15.86	38.55	30	-14.14
	6	2437	6.66	4.63	16.08	40.55	30	-13.92
	11	2462	6.89	4.89	16.23	41.98	30	-13.77
802.11n (HT20)	1	2412	7.96	6.25	17.02	50.35	30	-12.98
	6	2437	8.24	6.67	17.35	54.33	30	-12.65
	11	2462	8.50	7.08	17.67	58.48	30	-12.33

4. Power Spectral Density

4.1 Instrument Setting

Spectrum Function	Setting
Detector	Peak
RBW	≥ 3 kHz
VBW	$\geq 3 \times$ RBW
Sweep	Auto couple
Trace	Max hold
Span	1.5 times x 6dB bandwidth
Attenuation	Auto

4.2 Test Procedure

Step 1	Test procedure refer to clause 10.2 method PKPSD (peak PSD) of KDB 558074 D01.
Step 2	Using the maximum conducted output power in the fundamental emission demonstrates compliance. The EUT must be configured to transmit continuously at full power over the measurement duration.
Step 3	Use the peak marker function to determine the maximum amplitude level within the RBW.

4.3 Test Diagram

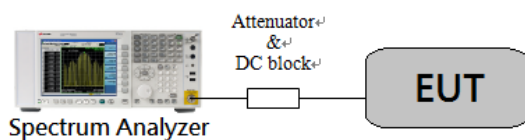

4.4 Limit

For digitally modulated systems, the power spectral density conducted from the intentional radiator to the antenna shall not be greater than 8 dBm in any 3 kHz band during any time interval of continuous transmission

4.5 Operating Environment Condition

Temperature (°C) :	26
Relative Humidity (%) :	56
Test Date :	2019/9/9

TEST REPORT

4.6 Test Results

Single TX

Mode	Channel	Frequency (MHz)	RBW factor	PSD in 10kHz	PSD in 3kHz		Limit (dBm)	Margin (dB)
					(dBm)	(mW)		
802.11b	1	2412	5.23	-6.11	-11.34	0.07	8	-19.34
	6	2437	5.23	-4.57	-9.80	0.10	8	-17.80
	11	2462	5.23	-5.59	-10.82	0.08	8	-18.82
802.11g	1	2412	5.23	-13.68	-18.91	0.01	8	-26.91
	6	2437	5.23	-12.14	-17.37	0.02	8	-25.37
	11	2462	5.23	-12.60	-17.83	0.02	8	-25.83
802.11n (HT20)	1	2412	5.23	-11.95	-17.18	0.02	8	-25.18
	6	2437	5.23	-12.21	-17.44	0.02	8	-25.44
	11	2462	5.23	-13.81	-19.04	0.01	8	-27.04

Note1: RBW Correction = $10 \cdot \log(10\text{kHz}/3\text{kHz}) = 5.229$

Note2: PSD in 3kHz = PSD in 10kHz – RBW Correction

Chain0: Power Spectral Density @ 802.11g Mode Ch 1

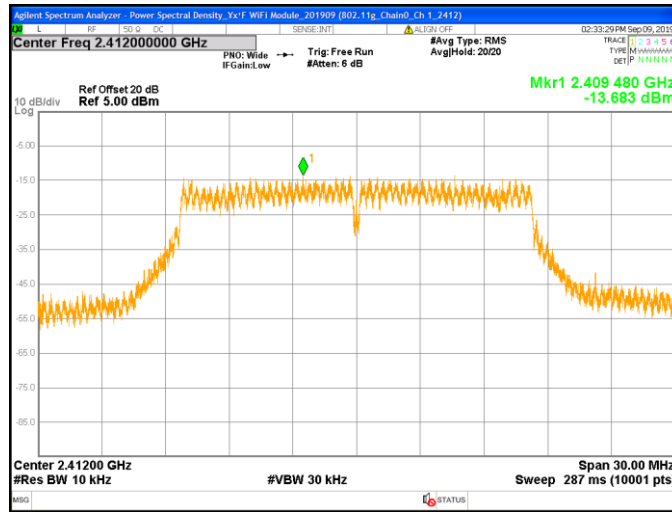

Chain0: Power Spectral Density @ 802.11g Mode Ch 6

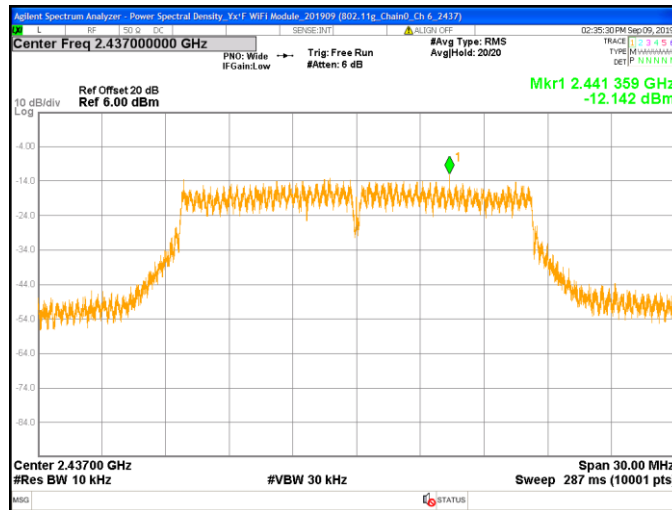

Chain0: Power Spectral Density @ 802.11g Mode Ch11

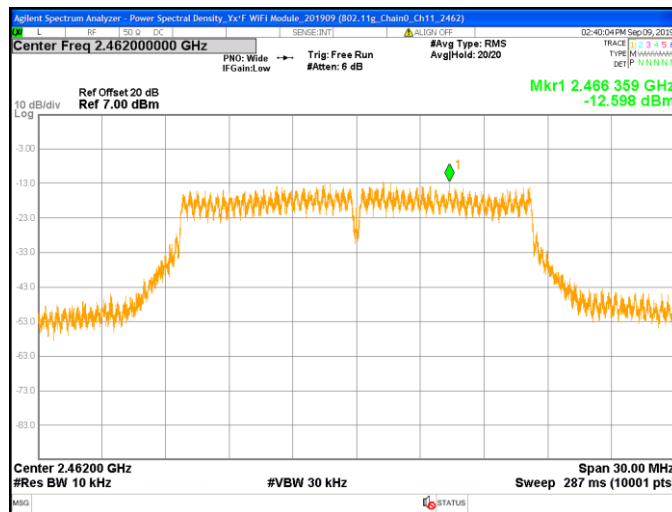

Chain0: Power Spectral Density @ 802.11n(HT20) Mode Ch 1

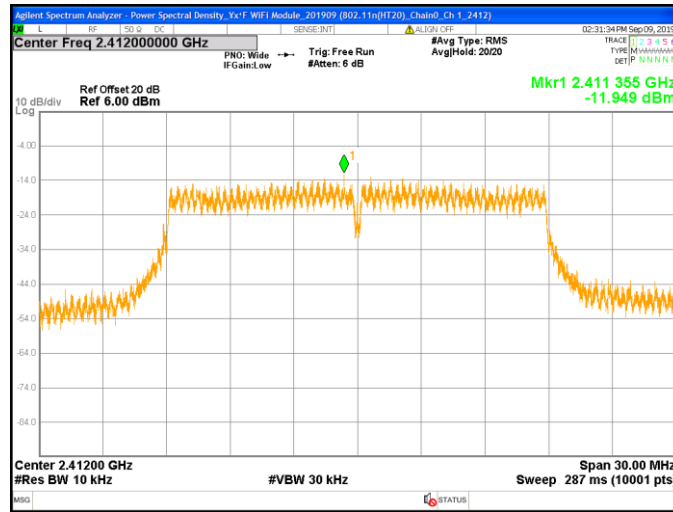

Chain0: Power Spectral Density @ 802.11n(HT20) Mode Ch 6

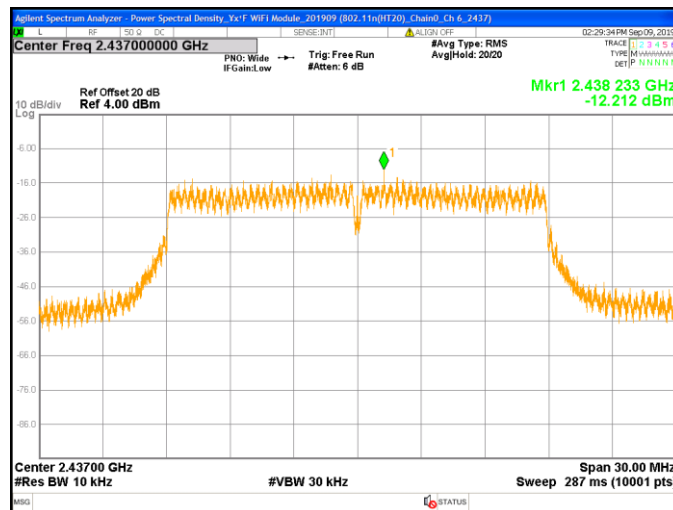

Chain0: Power Spectral Density @ 802.11n(HT20) Mode Ch11

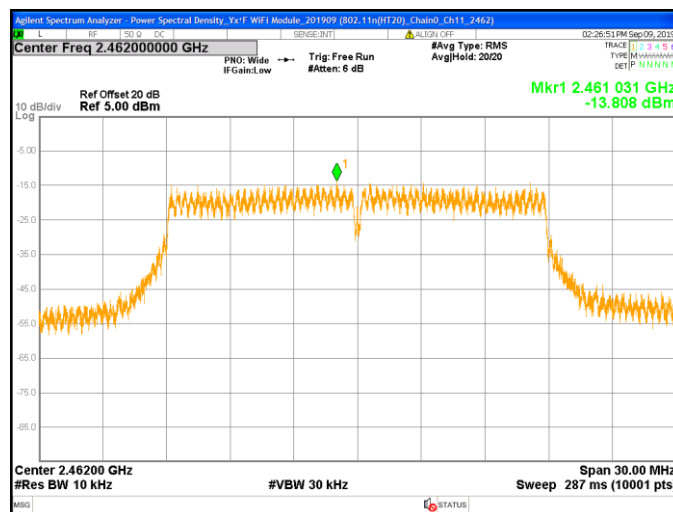

5. Emissions in Non-Restricted Frequency Bands

5.1 Instruments Setting

Spectrum Function	Setting (Reference Level)	Setting (Emission Level)
Detector	Peak	Peak
RBW	≥ 100 kHz	≥ 100 kHz
VBW	$\geq 3 \times$ RBW	$\geq 3 \times$ RBW
Sweep	Auto couple	Auto couple
Trace	Max hold	Max hold
Span	≥ 1.5 time 6dB bandwidth	
Attenuation	Auto	Auto

5.2 Test Procedure

- Step 1 The procedure was used in antenna-port conducted and connected to the spectrum analyzer.
- Step 2 Set instrument center frequency to center frequency.
- Step 3 Use the parameter configured in clause 5.1 to measure.
- Step 4 Use the peak marker function to determine the maximum amplitude level.

5.3 Test Diagram

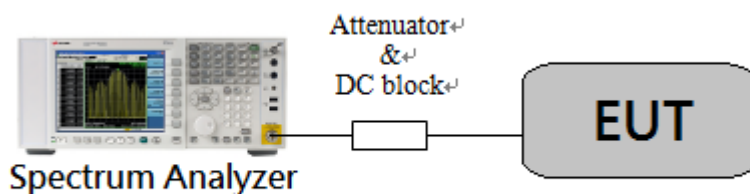

5.4 Limit

The peak output power measured in any 100 kHz bandwidth outside of the authorized frequency band shall be attenuated by at least 20 dB relative to the maximum in-band peak PSD level in 100 kHz

5.5 Operating Environment Condition

Temperature (°C) :	23
Relative Humidity (%) :	61
Test Date :	2019/9/9

5.6 Test Results

Chain0: Conducted Spurious @ 802.11b Mode Ch 1

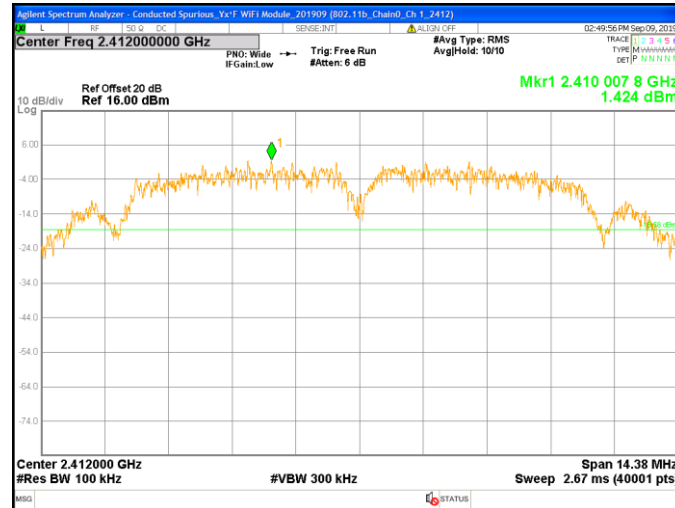

Chain0: Conducted Spurious @ 802.11b Mode Ch 1

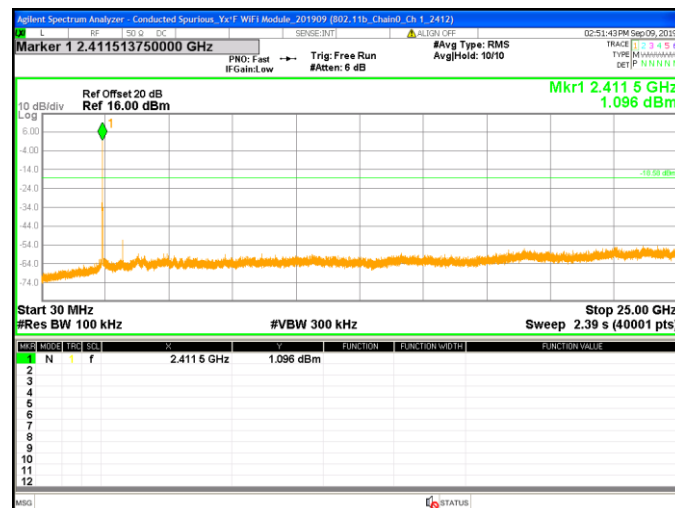

Chain0: Conducted Spurious @ 802.11b Mode Ch 6

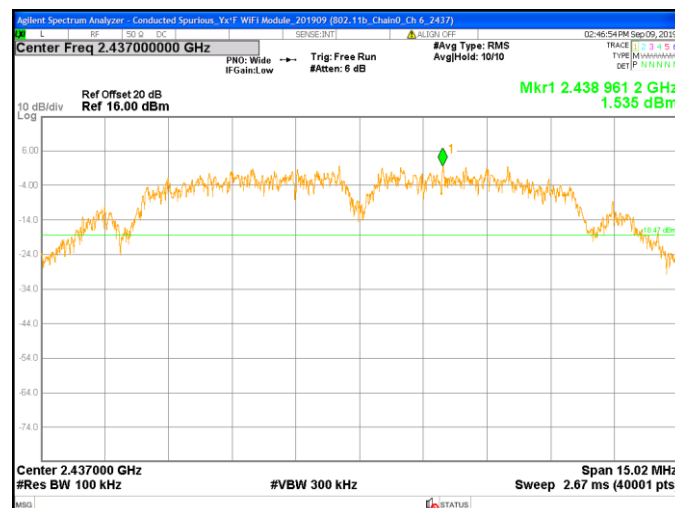

Chain0: Conducted Spurious @ 802.11g Mode Ch 1

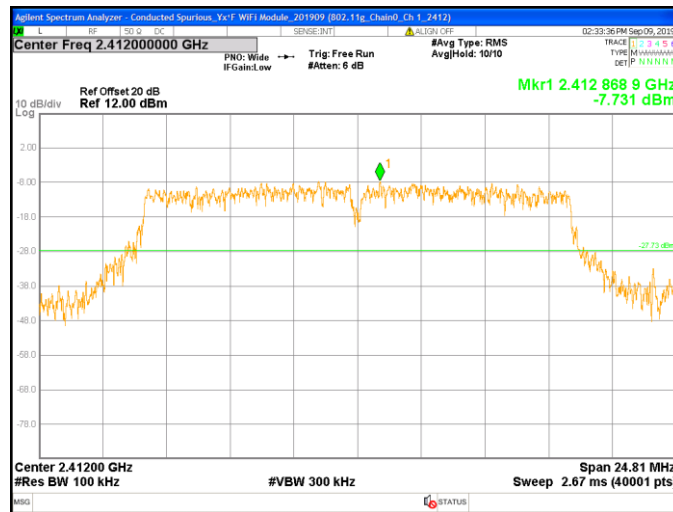

Chain0: Conducted Spurious @ 802.11g Mode Ch 1

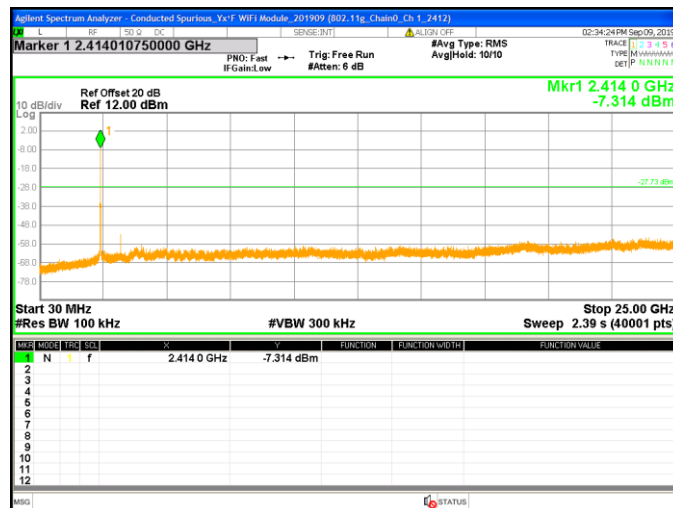

Chain0: Conducted Spurious @ 802.11g Mode Ch 6

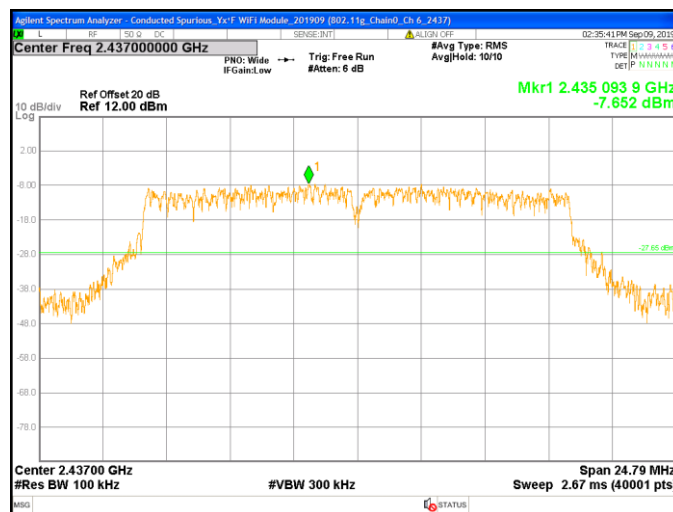

Chain0: Conducted Spurious @ 802.11n(HT20) Mode Ch 1

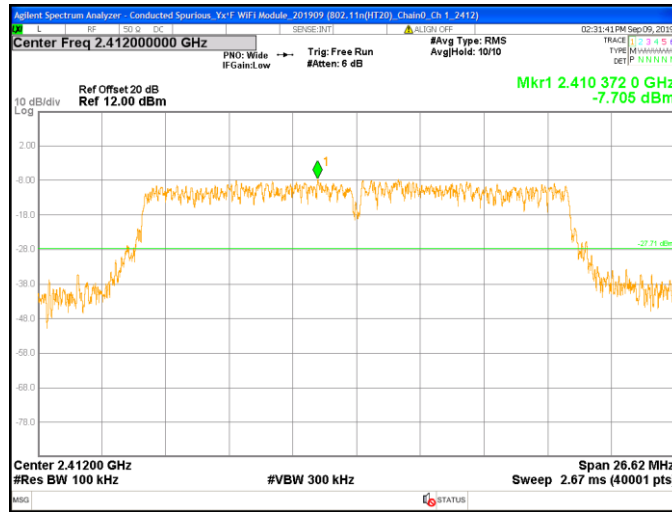

Chain0: Conducted Spurious @ 802.11n(HT20) Mode Ch 1

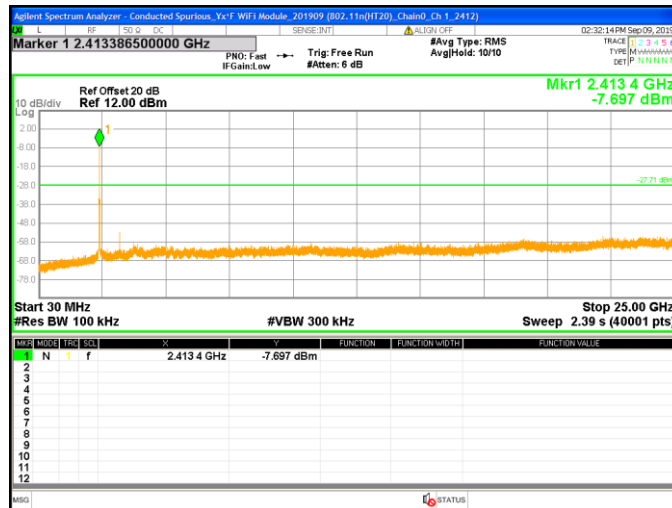

Chain0: Conducted Spurious @ 802.11n(HT20) Mode Ch 6

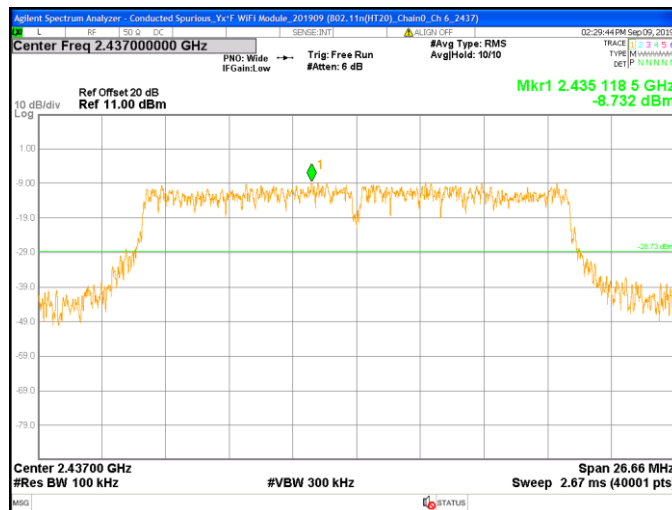

Chain0: Conducted Spurious @ 802.11n(HT20) Mode Ch 6

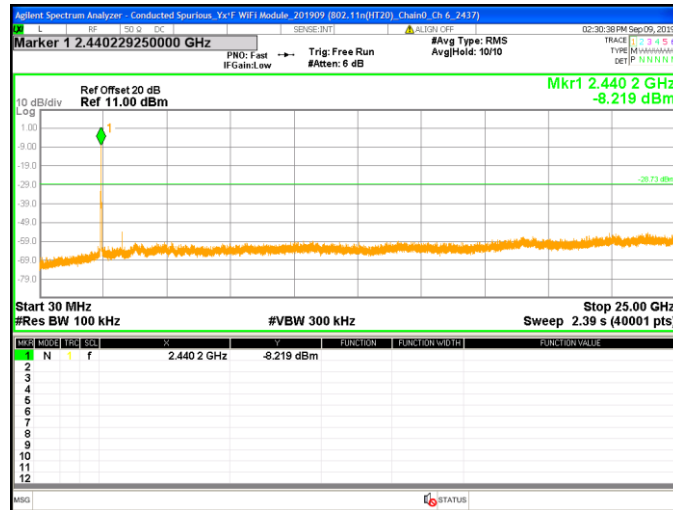

Chain0: Conducted Spurious @ 802.11n(HT20) Mode Ch11

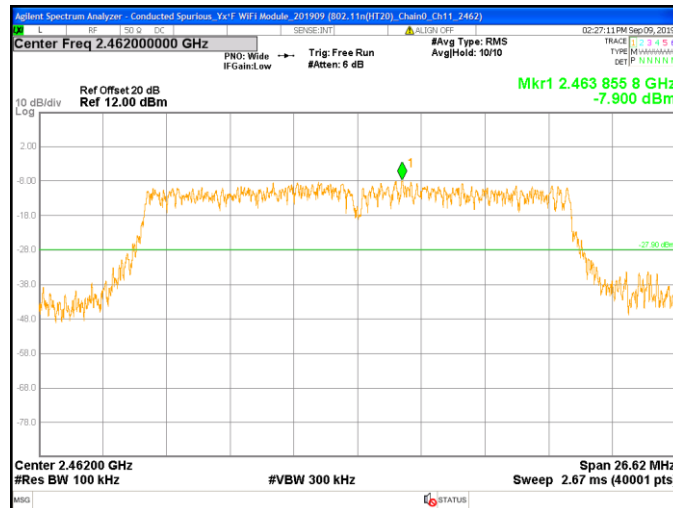

Chain0: Conducted Spurious @ 802.11n(HT20) Mode Ch11

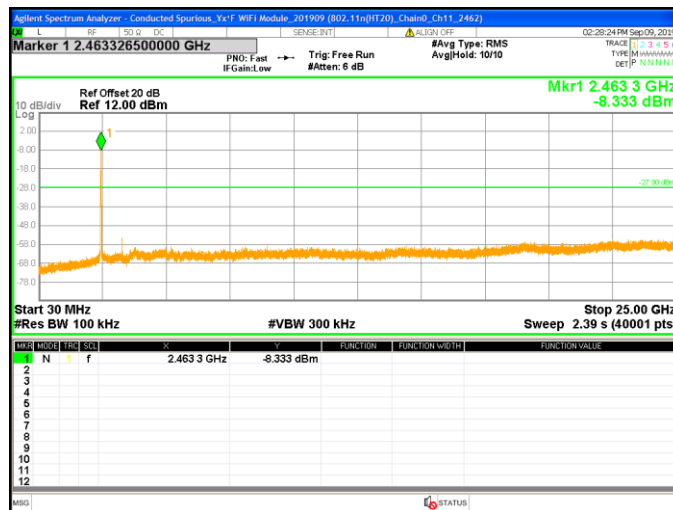

6. Emissions in Restricted Frequency Bands (Radiated emission measurements)

6.1 Instrument Setting

Receiver Function	Setting (Below 1GHz)	Setting (Above 1GHz)
Detector	QP	Peak and Average
RBW	9-150 kHz ; 200-300 Hz 0.15-30 MHz; 9-10 kHz 30-1000 MHz; 100-120 kHz	1MHz
VBW	$\geq 3 \times \text{RBW}$	3MHz
Sweep	Auto couple	Auto couple
Start Frequency	9 kHz	1GHz
Stop Frequency	1 GHz	Tenth harmonic
Attenuation	Auto	Auto

6.2 Test Procedure

Step 1	Configure the EUT according to ANSI C63.10:2013. The EUT was placed on the top of the turntable 0.8 meter (below 1GHz) and 1.5 meter (above 1GHz) above ground. The center of the receiving antenna mounted on the top of a height-variable antenna tower was placed 3 meters far away from the turntable.
Step 2	Power on the EUT and all the companion devices. The turntable was rotated by 360 degree to find the position of the maximum emission level.
Step 3	The height of the receiving antenna was varied between one meter and four meters above ground to find the maximum emission field strength of the both horizontal and vertical polarization.
Step 4	If find the frequencies above the limit or below within 3dB, the antenna tower was scan (from 1m to 4m) and then the turntable was rotated to find the maximum reading.
Step 5	Set the test-receiver system to peak or CISPR quasi-peak detector with specified bandwidth under maximum hold mode.
Step 6	For emissions above 1GHz, use 1MHz VBW and 3MHz RBW for reading in spectrum analyzer. Place the measurement antenna away from each area of the EUT determined to be a source of emissions at the specified measurement distance, while keeping the measurement antenna aimed at the source of emissions at each frequency of significant emissions, with polarization oriented for maximum response.
Step 7	If the emissions level of the EUT in peak mode was 3dB lower than the average limit specified then testing will be stopped and peak values of the EUT will be reported. Otherwise, the emissions which do not have 3dB margin will be measured using the quasi-peak method for below 1GHz.
Step 8	For testing above 1GHz, The emissions level of the EUT in peak mode was lower than average limit, then testing will be stopped and peak values of the EUT will be reported, otherwise, the emission will be measured in average mode again and reported.

TEST REPORT

Step 9	In case the emission is lower than 30MHz, loop antenna has to be used for measurement and the recorded data should be quasi-peak measured by receiver.
--------	--

6.3 Test Diagram

6.3.1 Radiated emission from 9kHz to 30MHz uses Loop Antenna:

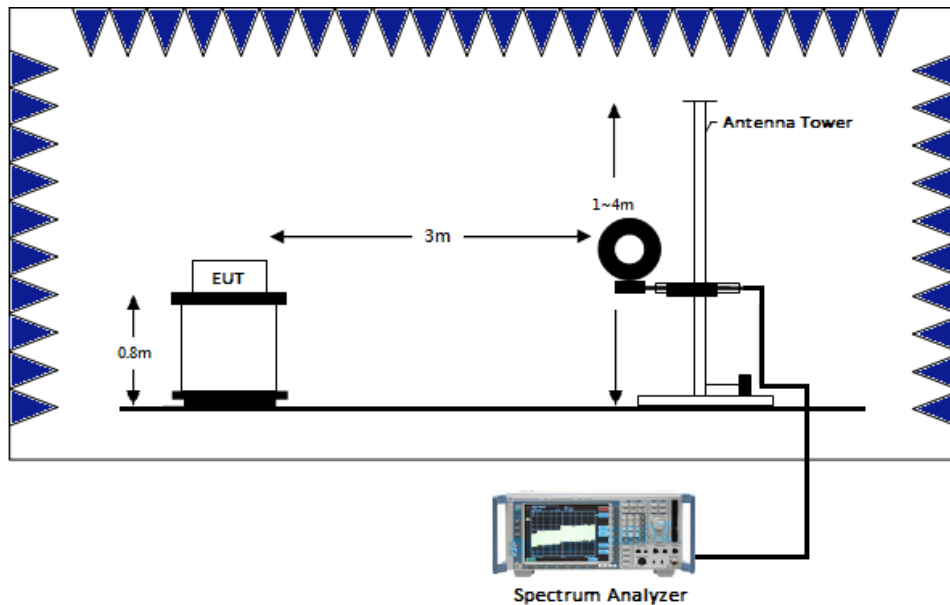

6.3.2 Radiated emission below 1GHz using Bilog Antenna

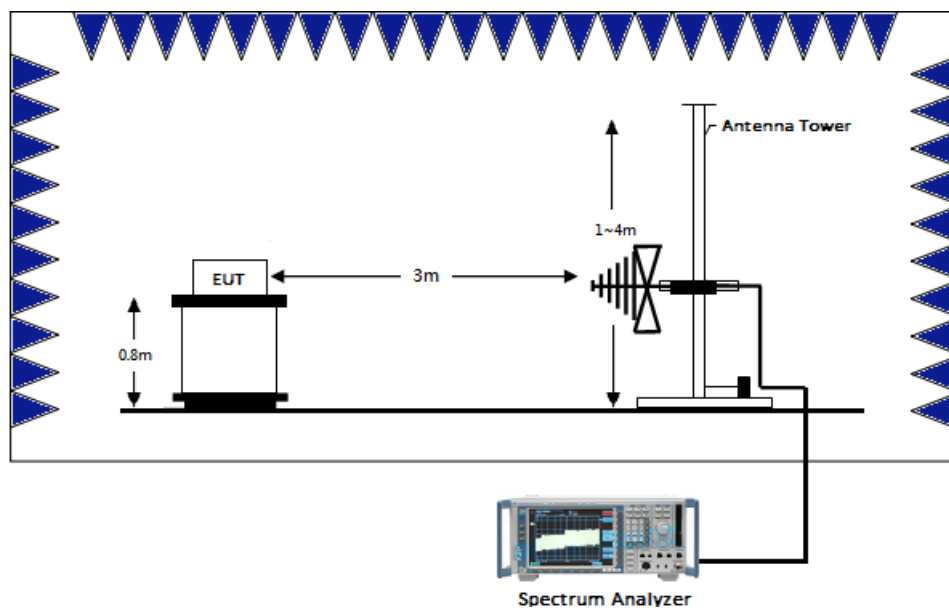

6.3.3 Radiated emission above 1GHz using Horn Antenna

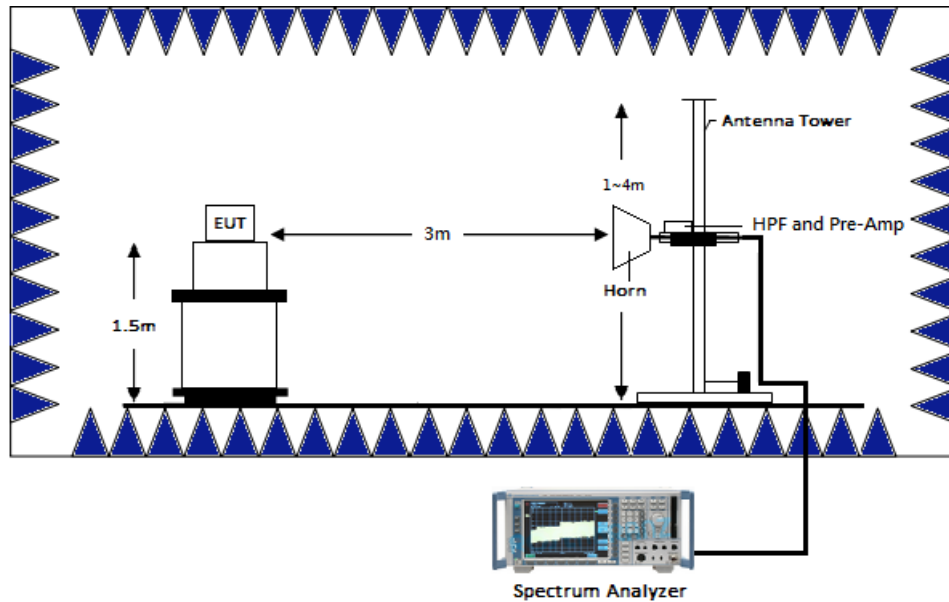

6.4 Limit

Frequency(MHz)	Field Strength(uV/m)	Measurement distance(m)
0.009~0.490	2400/F(kHz)	300
0.490~1.705	24000/F(kHz)	30
1.705~30	30	30
30-88	100	3
88-216	150	3
216-960	200	3
Above 960	500	3

Remark:

1. In the above table, the tighter limit applies at the band edges.
2. Distance refers to the distance in meters between the measuring instrument antenna and the closed point of any part of the device or system

6.5 Operating Environment Condition

Temperature (°C) :	25
Relative Humidity (%) :	63
Test Date :	2019/9/5

6.6 Test Result

6.6.1 Measurement results: frequencies 9kHz to 30MHz

The test was performed on EUT under 802.11b/g/n continuously transmitting mode. The worst case occurred at 802.11g Channel 6.

EUT: RS9113-N00-S1C

Frequency (MHz)	Detector	Correction Factor (dB/m)	Reading (dBμV)	Corrected Reading (dBμV/m)	Limit @ 3 m (dBμV/m)	Margin (dB)
0.02	PK	18.65	22.32	40.97	121.58	-80.61
0.04	PK	18.91	20.86	39.77	115.56	-75.79
0.06	PK	18.58	24.81	43.39	112.04	-68.65
0.09	QP	18.39	31.91	50.30	108.52	-58.22
0.12	PK	18.32	37.10	55.42	106.02	-50.60
0.14	PK	18.33	27.48	45.81	104.68	-58.87
0.15	PK	18.34	34.17	52.51	104.08	-51.57
0.21	PK	18.37	25.09	43.46	101.16	-57.70
0.45	PK	18.50	19.48	37.98	94.54	-56.56
0.87	QP	18.78	14.56	33.34	68.81	-35.47
1.28	QP	18.88	14.71	33.59	65.46	-31.87
1.82	QP	18.91	13.51	32.42	69.54	-37.12

Remark: Corr. Factor = Antenna Factor + Cable Loss

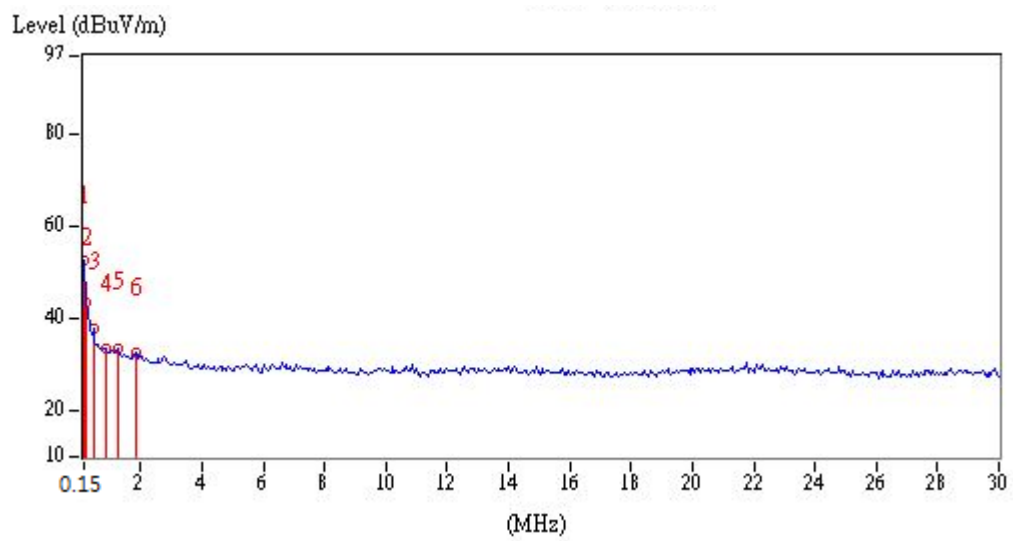
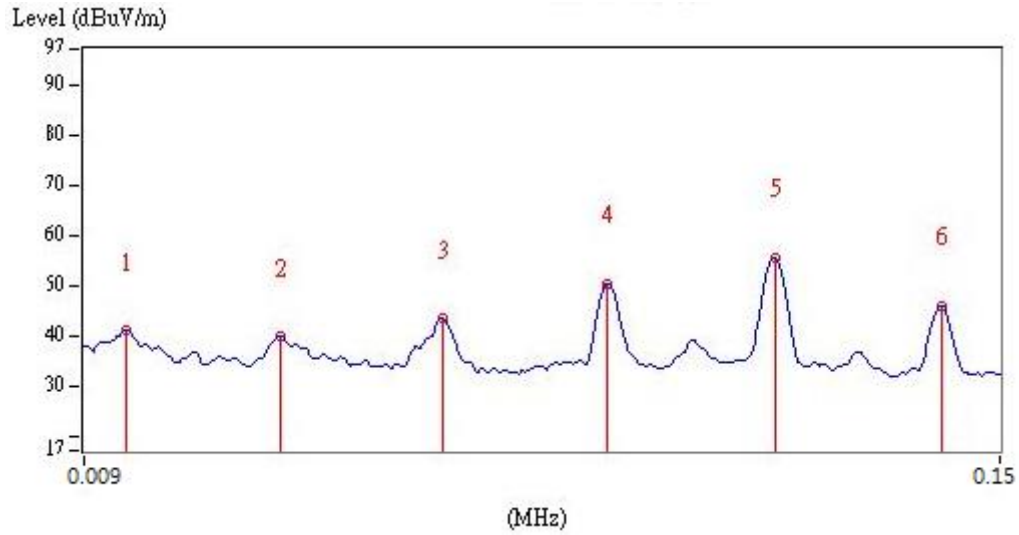

TEST REPORT

6.6.1 Measurement results: frequencies below 1 GHz

The test was performed on EUT under 802.11b/g/n continuously transmitting mode. The worst case occurred at 802.11g Channel 6.

EUT: RS9113-N00-S1C

Ant Polarity	Frequency (MHz)	Detector	Factor (dB/m)	Reading (dB μ V)	Corrected Reading (dB μ V/m)	Limit @ 3m (dB μ V/m)	Margin (dB)
Vertical	280.26	QP	21.24	2.51	23.75	46.00	-22.25
Vertical	359.80	QP	23.18	8.36	31.54	46.00	-14.46
Vertical	439.34	QP	25.30	4.94	30.24	46.00	-15.76
Vertical	520.82	QP	26.74	6.61	33.35	46.00	-12.65
Vertical	600.36	QP	28.63	6.48	35.11	46.00	-10.89
Vertical	732.28	QP	30.51	3.11	33.62	46.00	-12.38

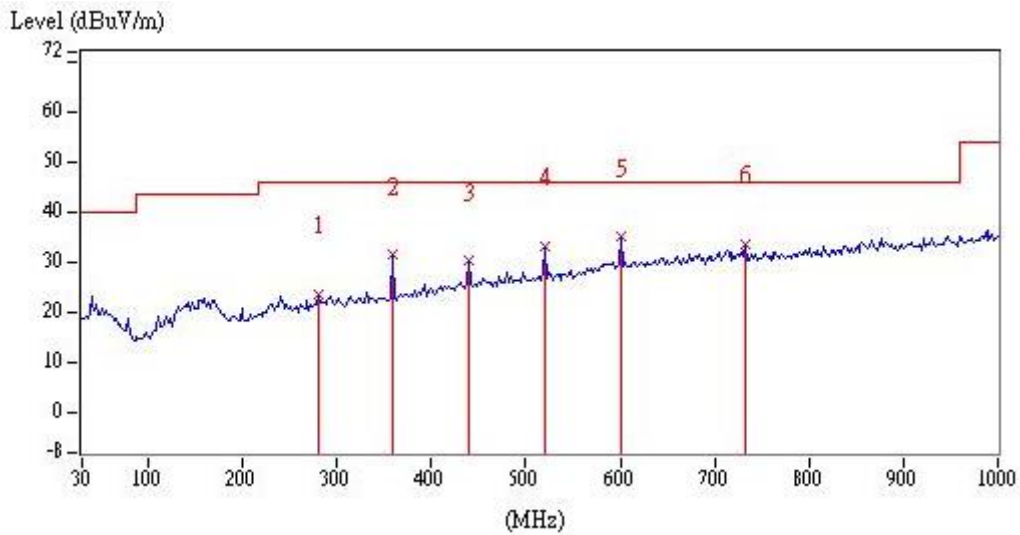

TEST REPORT

Ant Polarity	Frequency (MHz)	Detector	Factor (dB/m)	Reading (dB μ V)	Corrected Reading (dB μ V/m)	Limit @ 3m (dB μ V/m)	Margin (dB)
Horizontal	280.26	QP	21.24	5.17	26.41	46.00	-19.59
Horizontal	359.80	QP	23.18	8.20	31.38	46.00	-14.62
Horizontal	439.34	QP	25.30	10.11	35.41	46.00	-10.59
Horizontal	520.82	QP	26.74	6.87	33.61	46.00	-12.39
Horizontal	600.36	QP	28.63	4.28	32.91	46.00	-13.09
Horizontal	840.92	QP	32.02	5.49	37.51	46.00	-8.49

Remark: Corr. Factor = Antenna Factor + Cable Loss

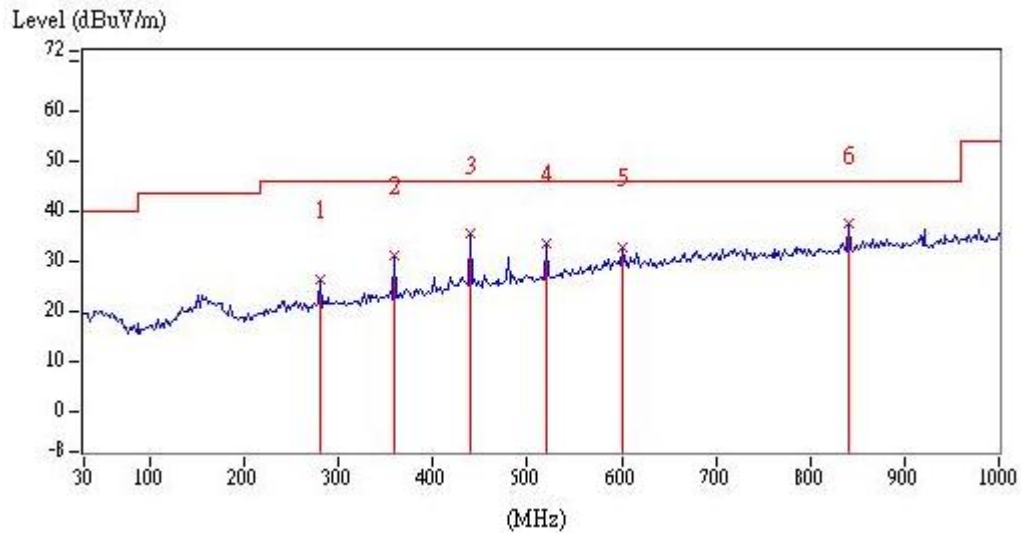

6.6.2 Measurement results: frequency above 1GHz to 25GHz

EUT: RS9113-N00-S1C

Chain0

Mode	Frequency (MHz)	Spectrum Analyzer Detector	Ant. Pol. (H/V)	Correction Factor (dB/m)	Reading (dBμV)	Corrected Reading (dBμV/m)	Limit @ 3 m (dBμV/m)	Margin (dB)
802.11b_Ch1	4824	PK	V	8.71	35.33	44.04	74.00	-29.96
	4824	PK	H	8.71	35.73	44.44	74.00	-29.56
802.11b_Ch6	4874	PK	V	8.95	35.43	44.38	74.00	-29.62
	7311	PK	V	16.59	32.67	49.26	74.00	-24.74
	4874	PK	H	8.95	35.25	44.20	74.00	-29.80
	7311	PK	H	16.59	30.40	46.99	74.00	-27.01
802.11b_Ch11	4924	PK	V	9.19	34.48	43.67	74.00	-30.33
	7386	PK	V	16.89	33.15	50.04	74.00	-23.96
	4924	PK	H	9.19	33.26	42.45	74.00	-31.55
	7386	PK	H	16.89	29.22	46.11	74.00	-27.89
802.11g_Ch1	4824	PK	V	8.71	34.80	43.51	74.00	-30.49
	4824	PK	H	8.71	33.99	42.70	74.00	-31.30
802.11g_Ch6	4874	PK	V	8.95	33.01	41.96	74.00	-32.04
	4874	PK	H	8.95	33.56	42.51	74.00	-31.49
802.11g_Ch11	4924	PK	V	9.19	33.22	42.41	74.00	-31.59
	4924	PK	H	9.19	33.92	43.11	74.00	-30.89
802.11n(HT20)_Ch1	4824	PK	V	8.71	33.94	42.65	74.00	-31.35
	4824	PK	H	8.71	33.24	41.95	74.00	-32.05
802.11n(HT20)_Ch6	4874	PK	V	8.95	32.61	41.56	74.00	-32.44
	4874	PK	H	8.95	33.42	42.37	74.00	-31.63
802.11n(HT20)_Ch11	4924	PK	V	9.19	32.43	41.62	74.00	-32.38
	4924	PK	H	9.19	32.56	41.75	74.00	-32.25

Remark: Correction Factor = Antenna Factor + Cable Loss + High Pass Filter Loss - Pre_Amplifier Gain

7. Emission on Band Edge**7.1 Instrument Setting**

Spectrum Function	Setting
Detector	Peak and Average
RBW	1MHz
VBW	3MHz
Sweep	Auto couple
Restrict bands	2310 MHz ~ 2390 MHz 2483.5 MHz ~ 2500 MHz
Attenuation	Auto

7.2 Test Procedure

The test procedure is the same as Emissions in Restricted Frequency Bands (Radiated emission measurements).

7.3 Operating Environment Condition

Temperature (°C) :	27
Relative Humidity (%) :	58
Test Date :	2019/8/29

7.4 Test Results

EUT: RS9113-N00-S1C

Mode	Frequency (MHz)	Spectrum Analyzer Detector	Ant. Pol. (H/V)	Correction Factor (dB/m)	Reading (dBμV)	Corrected Reading (dBμV/m)	Limit @ 3 m (dBμV/m)	Margin (dB)	Restricted band (MHz)
802.11b	2390.00	PK	H	34.56	24.13	58.69	74	-15.31	2310~2390
	2390.00	AV	H	34.56	15.69	50.25	54	-3.75	
	2483.98	PK	H	34.93	24.67	59.60	74	-14.40	2483.5~2500
	2483.50	AV	H	34.93	15.46	50.39	54	-3.61	
802.11g	2390.00	PK	H	34.56	31.81	66.37	74	-7.63	2310~2390
	2390.00	AV	H	34.56	14.26	48.82	54	-5.18	
	2483.50	PK	H	34.93	35.17	70.10	74	-3.90	2483.5~2500
	2483.50	AV	H	34.93	17.37	52.30	54	-1.70	
802.11n (HT20)	2390.00	PK	H	34.56	37.39	71.95	74	-2.05	2310~2390
	2390.00	AV	H	34.56	17.55	52.11	54	-1.89	
	2483.50	PK	H	34.93	37.93	72.86	74	-1.14	2483.5~2500
	2483.50	AV	H	34.93	18.81	53.74	54	-0.26	

Remark: Correction Factor = Antenna Factor + Cable Loss

Chain0: Restricted Band Bandedge @ 802.11b Mode Ch1 PK

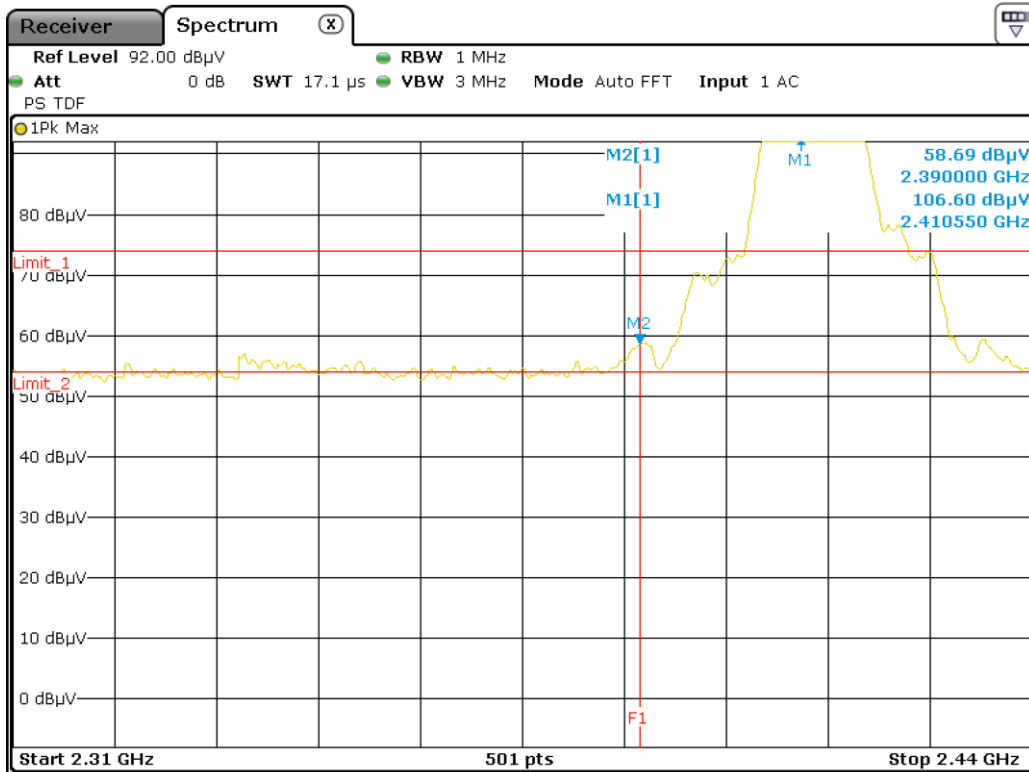

Date: 29.AUG.2019 12:38:42

Chain0: Restricted Band Bandedge @ 802.11b Mode Ch1 AV

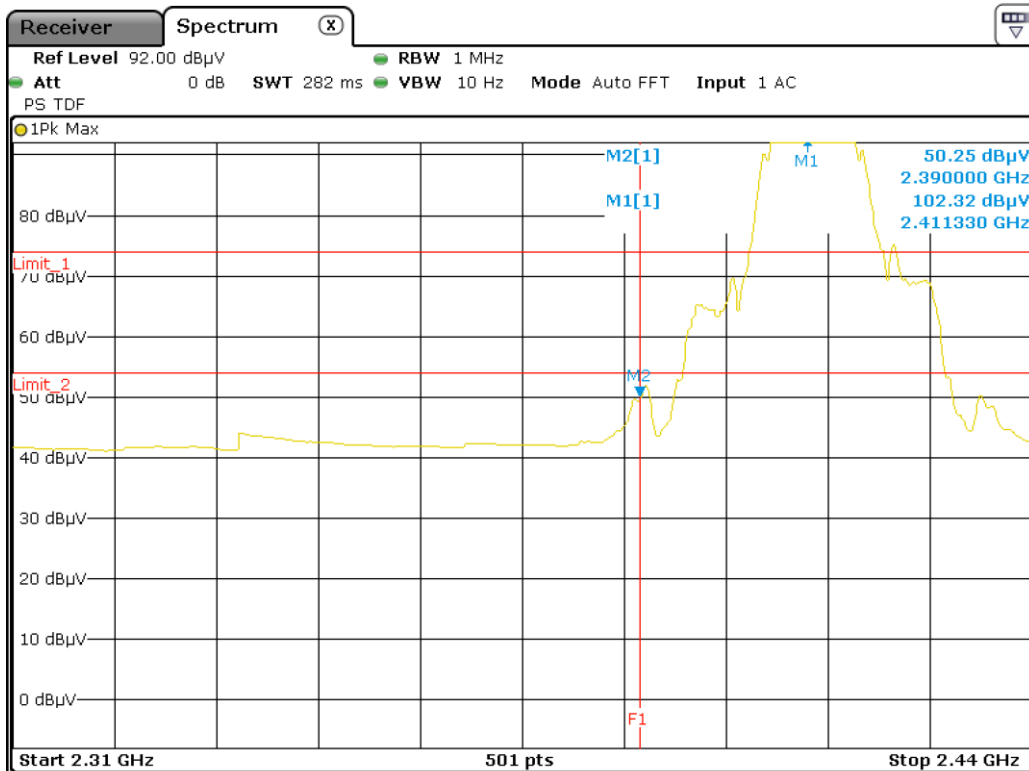

Date: 29.AUG.2019 12:40:48

Chain0: Restricted Band Bandedge @ 802.11b Mode Ch11 PK

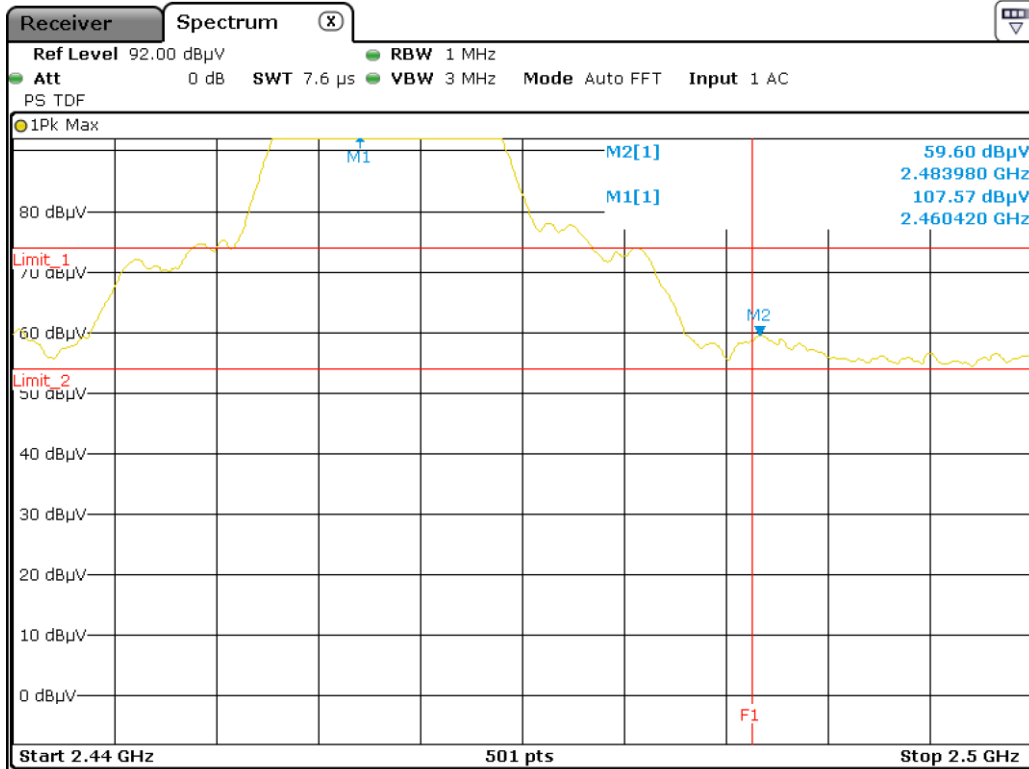

Date: 29.AUG.2019 12:36:29

Chain0: Restricted Band Bandedge @ 802.11b Mode Ch11 AV

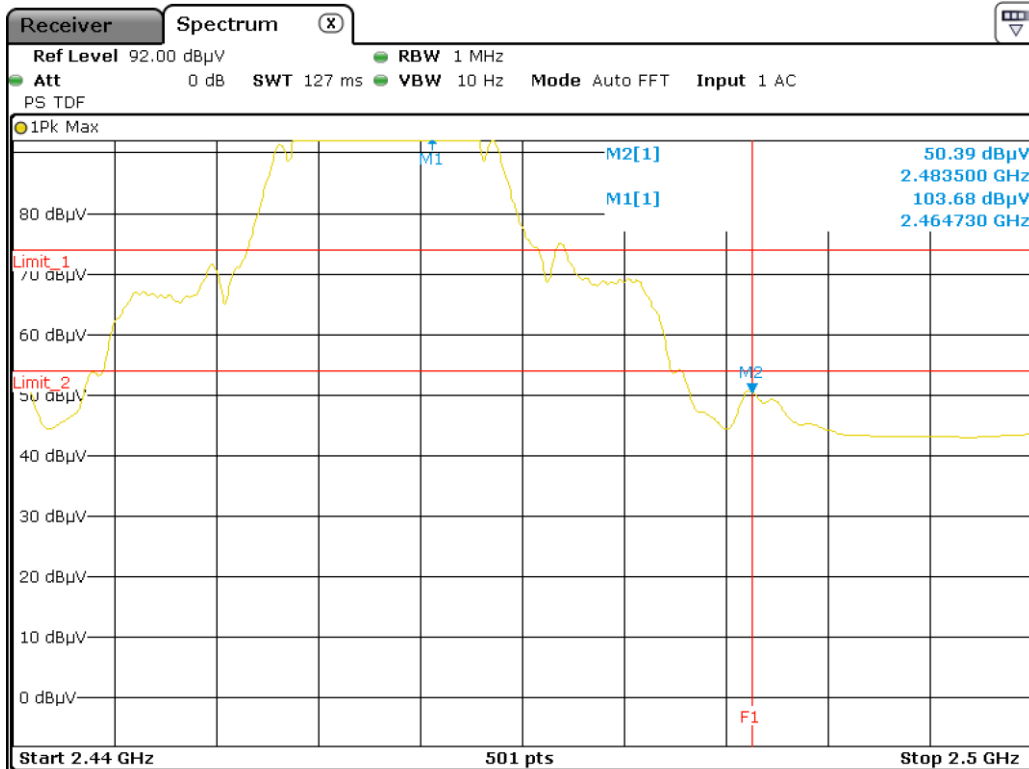

Date: 29.AUG.2019 12:33:53

Chain0: Restricted Band Bandedge @ 802.11g Mode Ch1 PK

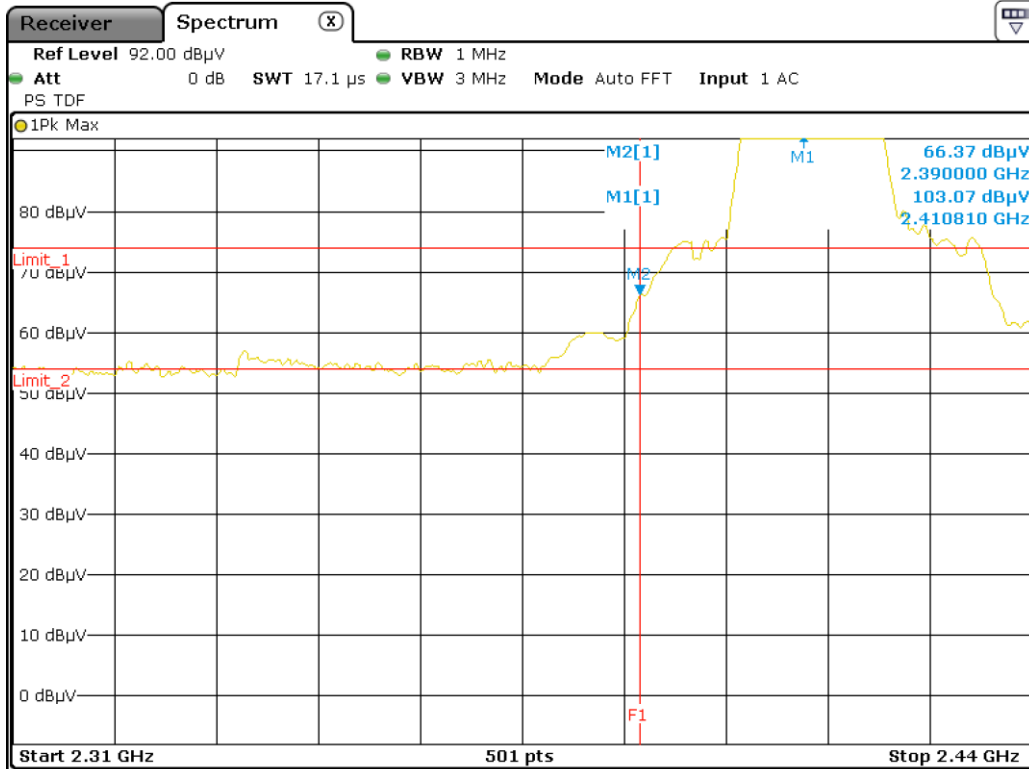

Date: 29.AUG.2019 12:44:25

Chain0: Restricted Band Bandedge @ 802.11g Mode Ch1 AV

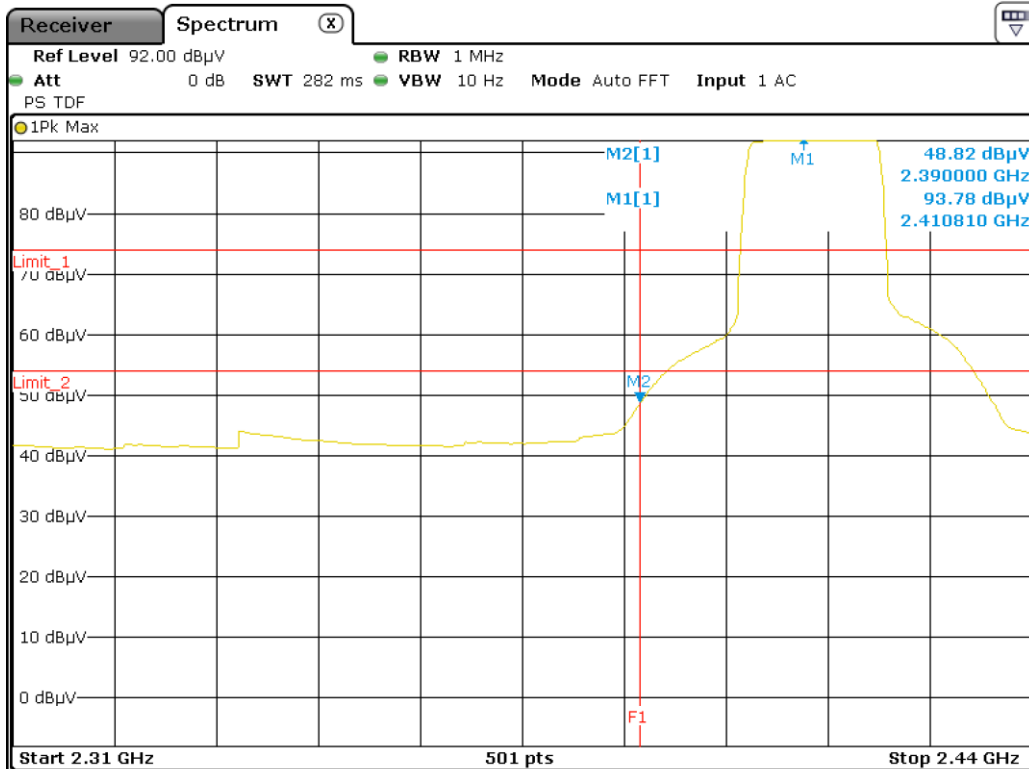

Date: 29.AUG.2019 12:48:36

Chain0: Restricted Band Bandedge @ 802.11g Mode Ch11 PK

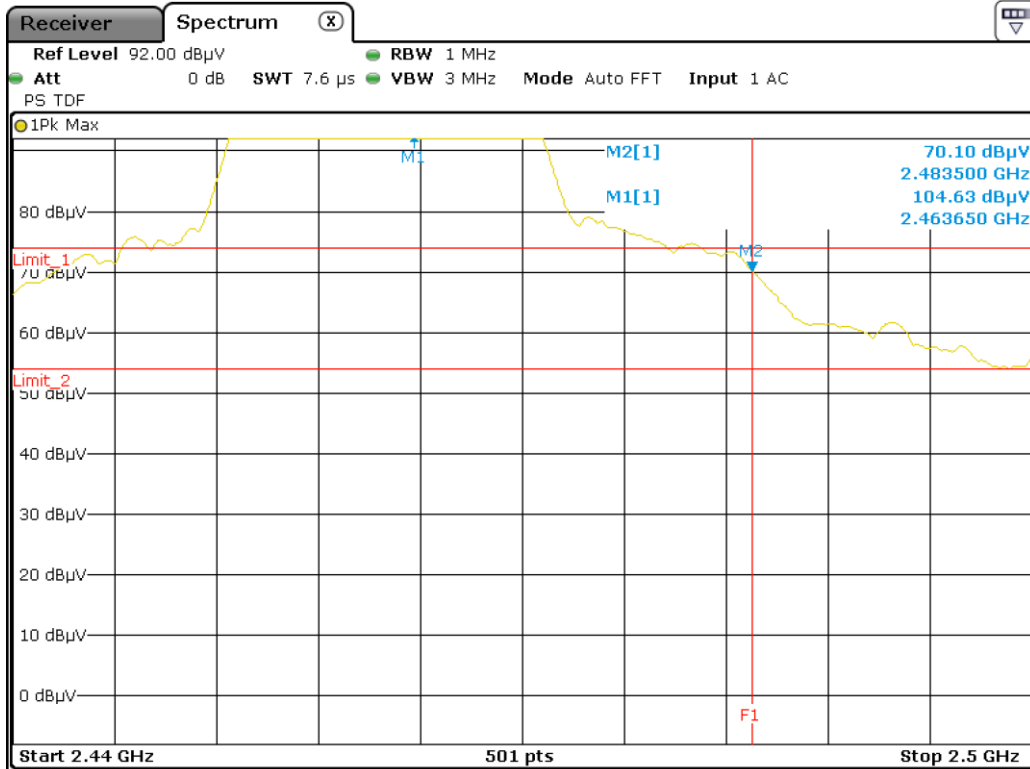

Date: 29.AUG.2019 12:31:17

Chain0: Restricted Band Bandedge @ 802.11g Mode Ch11 AV

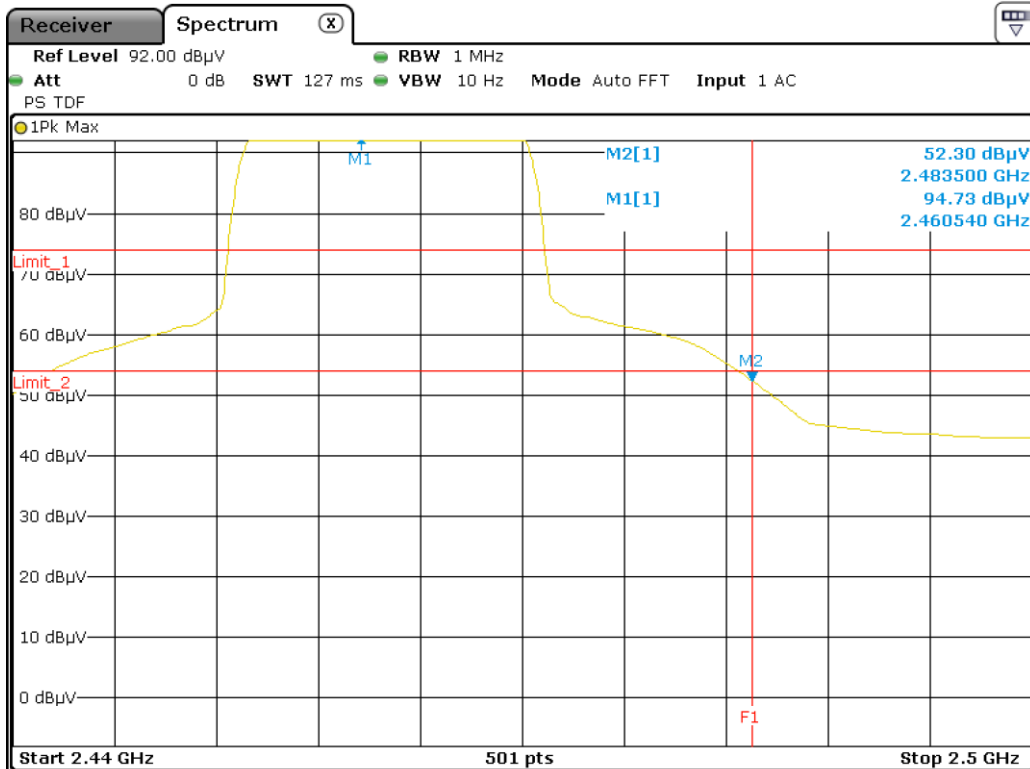

Date: 29.AUG.2019 12:30:08

Chain0: Restricted Band Bandedge @ 802.11n(HT20) Mode Ch1 PK

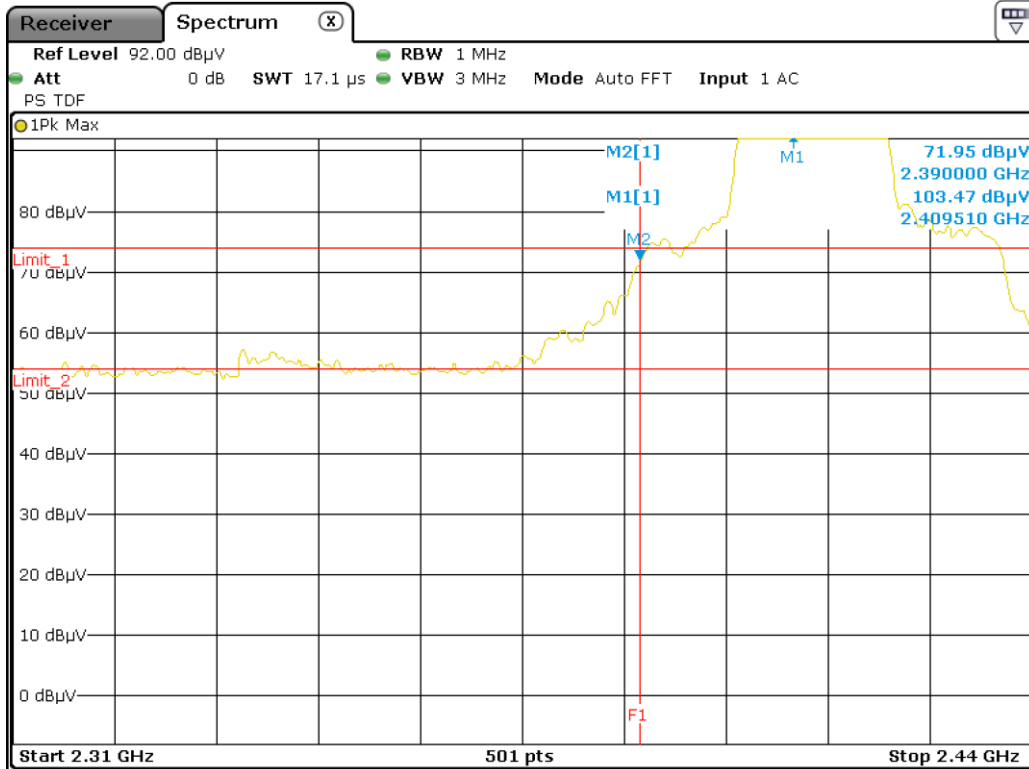

Date: 29.AUG.2019 12:51:33

Chain0: Restricted Band Bandedge @ 802.11n(HT20) Mode Ch1 AV

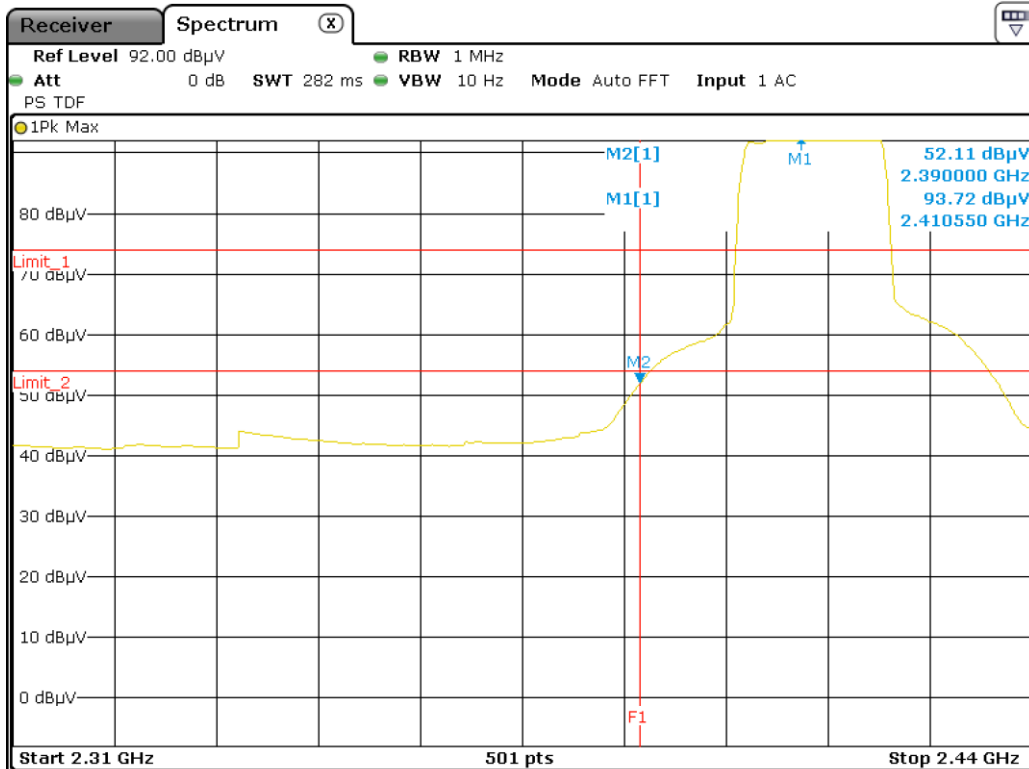

Date: 29.AUG.2019 12:56:15

Chain0: Restricted Band Bandedge @ 802.11n(HT20) Mode Ch11 PK

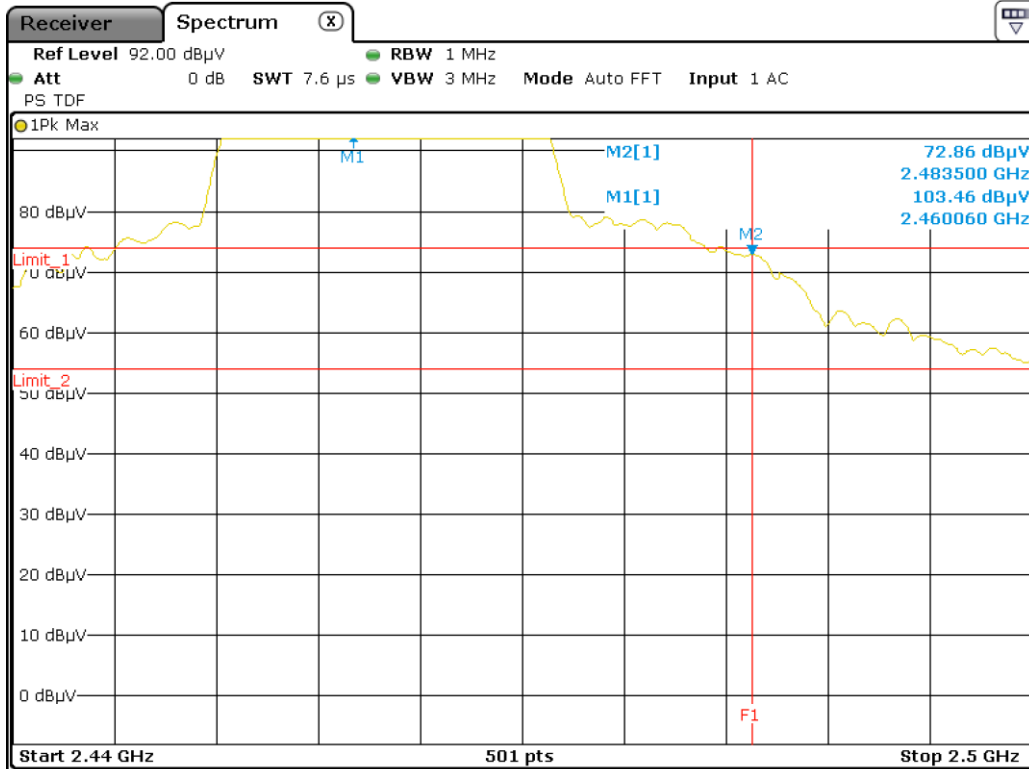

Date: 29.AUG.2019 12:26:06

Chain0: Restricted Band Bandedge @ 802.11n(HT20) Mode Ch11 AV

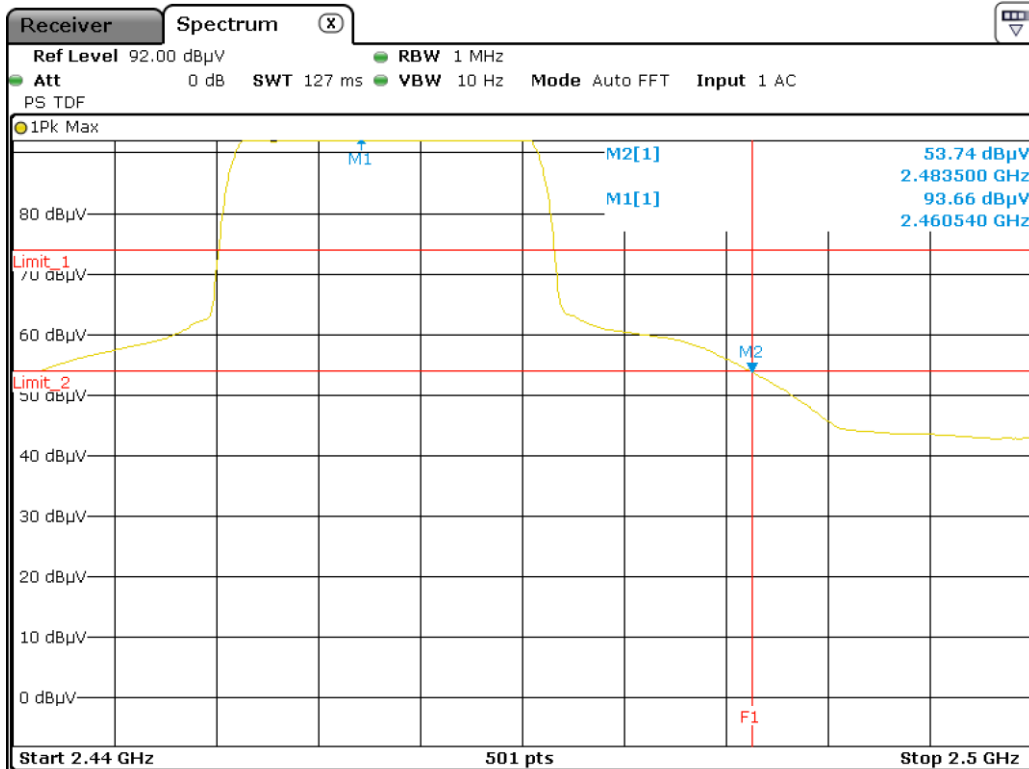

Date: 29.AUG.2019 12:18:49

8. AC Power Line Conducted Emission

8.1 Measuring instrument setting

Receiver Function	Setting
Detector	QP
Start frequency	0.15MHz
Stop frequency	30MHz
IF bandwidth	9 kHz
Attenuation	10dB

8.2 Test Procedure

Step 1	Configure the EUT according to ANSI C63.10:2013. The EUT or host of EHT has to be placed 0.4 meter far from the conducting wall of the shielding room and at least 80 centimeters from any other grounded conducting surface.
Step 2	Connect EUT or host of EUT to the power mains through a line impedance stabilization network.
Step 3	All the companion devices are connected to the other LISN. The LISN should provide 50Uh/50ohms coupling impedance.
Step 4	The frequency range from 150 kHz to 30MHz was searched.
Step 5	Set the test-receiver system to peak detector and specified bandwidth with maximum hold mode.
Step 6	The measurement has to be done between each power line and ground at the power terminal.

8.3 Test Diagram

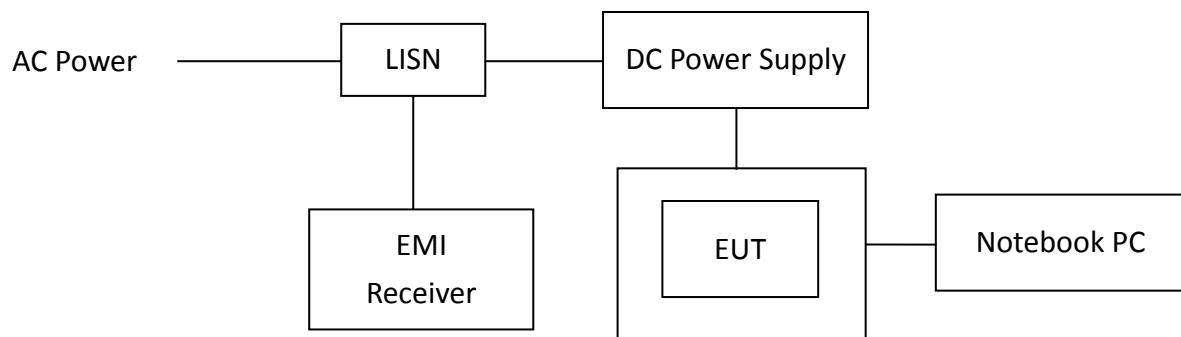

8.4 Limit

Frequency (MHz)	Conducted Limit (dBuV)	
	Q.P.	Ave.
0.15~0.50	66 – 56	56 – 46
0.50~5.00	56	46
5.00~30.0	60	50

8.5 Operating Environment Condition

Temperature (°C) :	24
Relative Humidity (%) :	63
Test Date :	2019/9/9

TEST REPORT

8.6 Test Results

Phase: Live Line
 Model No.: RS9113-N00-S1C
 Test Condition: Tx mode

Frequency (MHz)	Corr. Factor (dB)	Reading QP (dBuV)	Level QP (dBuV)	Limit QP (dBuV)	Reading AV (dBuV)	Level AV (dBuV)	Limit AV (dBuV)	Margin (dB)	
								QP	AV
0.189	9.69	15.69	25.38	64.06	1.55	11.25	54.06	-38.68	-42.82
0.213	9.69	14.24	23.93	63.10	1.32	11.01	53.10	-39.16	-42.09
0.361	9.70	8.90	18.59	58.69	0.62	10.31	48.69	-40.10	-38.38
0.527	9.70	4.38	14.09	56.00	0.32	10.03	46.00	-41.91	-35.97
12.001	9.82	38.56	48.38	60.00	38.03	47.85	50.00	-11.62	-2.15
24.001	9.80	28.22	38.02	60.00	25.10	34.90	50.00	-21.98	-15.10

Remark:

1. Corr. Factor (dB) = LISN Factor (dB) + Cable Loss (dB)
2. Level (dBuV) = Corr. Factor (dB) + Reading (dBuV)
3. Margin (dB) = Level (dBuV) – Limit (dBuV)

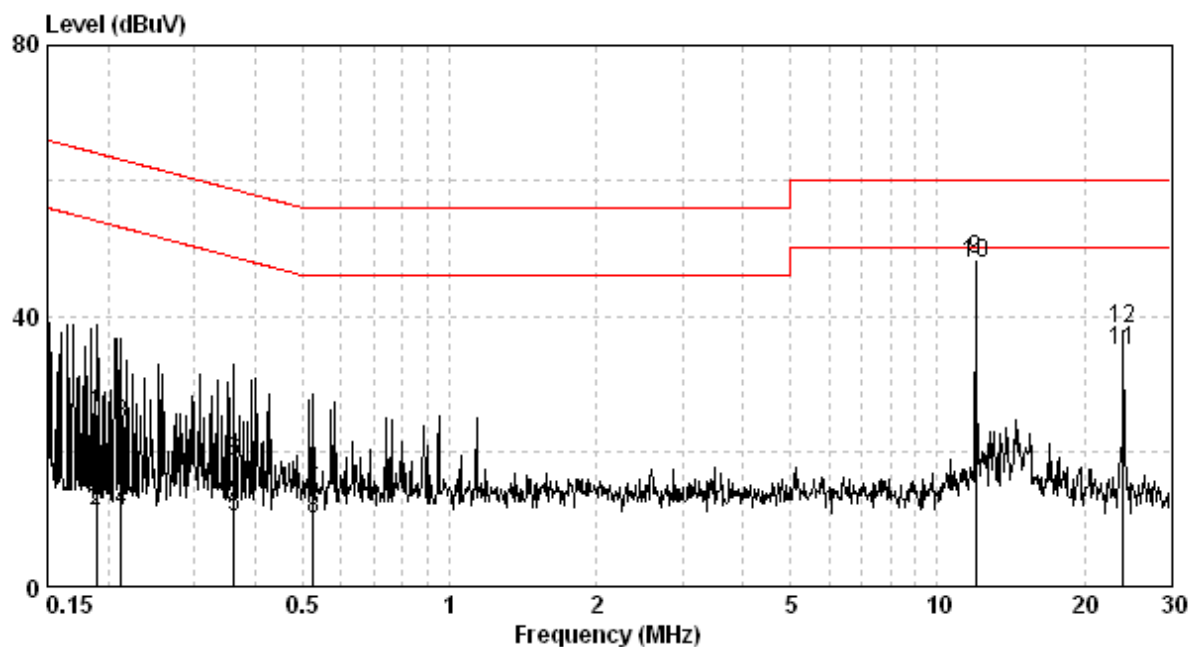

TEST REPORT

Phase: Neutral Line
 Model No.: RS9113-N00-S1C
 Test Condition: Tx mode

Frequency (MHz)	Corr. Factor (dB)	Reading QP (dBuV)	Level QP (dBuV)	Limit QP (dBuV)	Reading AV (dBuV)	Level AV (dBuV)	Limit AV (dBuV)	Margin (dB)	
								QP	AV
0.170	9.71	16.41	26.12	64.94	1.34	11.05	54.94	-38.82	-43.89
0.190	9.71	15.89	25.60	64.02	1.74	11.45	54.02	-38.42	-42.57
0.334	9.71	9.41	19.12	59.35	1.38	11.09	49.35	-40.23	-38.27
0.576	9.72	4.38	14.10	56.00	1.26	10.98	46.00	-41.90	-35.02
12.001	9.87	38.34	48.21	60.00	37.87	47.74	50.00	-11.79	-2.26
24.001	9.92	30.20	40.12	60.00	27.05	36.97	50.00	-19.88	-13.03

Remark:

1. Corr. Factor (dB) = LISN Factor (dB) + Cable Loss (dB)
2. Level (dBuV) = Corr. Factor (dB) + Reading (dBuV)
3. Margin (dB) = Level (dBuV) – Limit (dBuV)

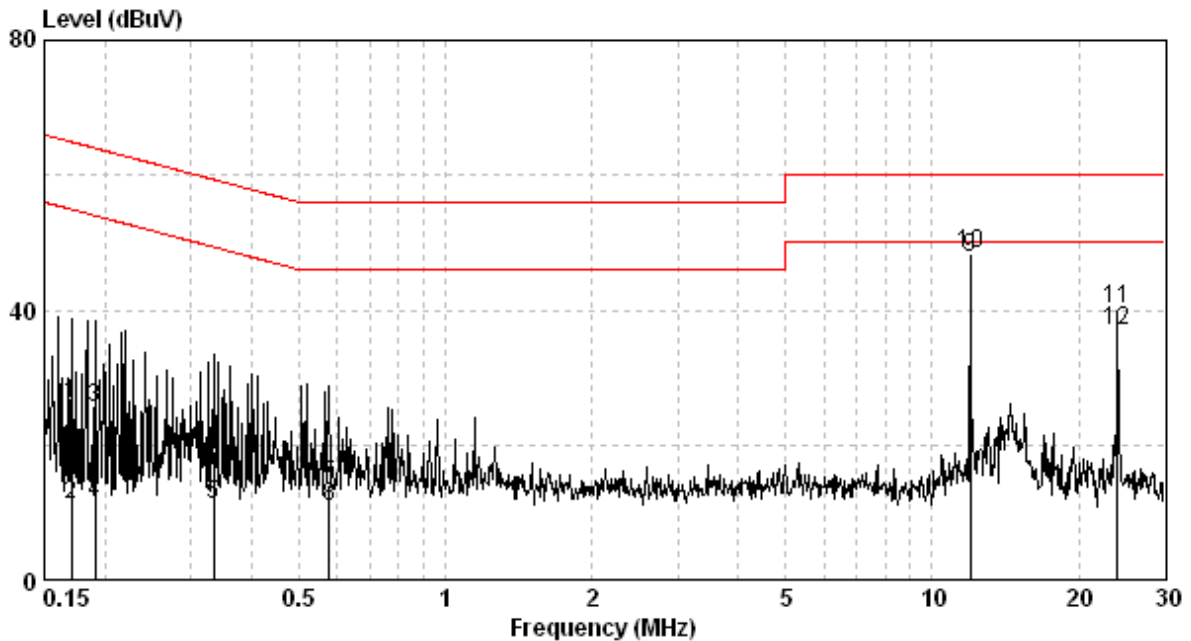

Appendix A: Test equipment list

Test Equipment/ Test site	Brand	Model No.	Serial No.	Calibration Date	Next Calibration Date
ESCI EMI Test Receiver	Rohde & Schwarz	ESCI	100018	2018/11/14	2019/11/13
Spectrum Analyzer	Rohde & Schwarz	FSP30	100137	2019/08/29	2020/08/27
Signal Analyzer	Agilent	N9030A	MY51380492	2019/08/21	2020/08/19
Active Loop Antenna	SCHWARZBECK MESS-ELEKTRONIC	FMZB1519	1519-067	2019/04/19	2020/04/17
Broadband Antenna	SHWARZBECK	VULB 9168	9168-172	2019/06/05	2020/06/03
Horn Antenna (1-18G)	SHWARZBECK	BBHA 9120 D	9120D-456	2019/02/01	2020/01/31
Power Meter	Anritsu	ML2495A	0844001	2018/10/29	2019/10/28
Power Sensor	Anritsu	MA2411B	0738452	2018/10/29	2019/10/28
966-2(A) Cable 9kHz~26.5GHz	SUHNER	SMA / EX 100	N/A	2019/08/19	2020/08/17
966-2(B) Cable 9kHz~26.5GHz	SUHNER	SUCOFLEX 104P	CB0005	2019/08/19	2020/08/17
RF Cable 9kHz~26.5GHz	SUHNER	SUCOFLEX 102	CB0006	2019/05/02	2020/04/30
Hight Pass Filter	Wainwright	WHKX3.0/18G-12 SS	N/A	2019/05/30	2020/05/28
966-2_3m Semi-Anechoic Chamber	966_2	CEM-966_2	N/A	2019/02/23	2020/02/22

Note: No Calibration Required (NCR)

Test Equipment/ Test site	Brand	Model No.	Serial No.	Calibration Date	Next Calibration Date
EMI Receiver	R&S	ESCI	100059	2018/11/07	2019/11/06
Two-Line V-Network	R&S	ENV216	101159	2019/06/12	2020/06/10
Two-Line -V-Network	R&S	ESH3-Z5	825562/003	2019/08/27	2020/08/25
CON-1 Shielded Room	N/A	N/A	N/A	NCR	NCR
CON-1 Cable	SUHNER	SUCOFLEX-104	26438414	2019/05/02	2020/04/30
Test software	Audix	e3	4.20040112L	NCR	NCR

Note: No Calibration Required (NCR).

Appendix B: Measurement Uncertainty

This uncertainty represents an expanded uncertainty expressed at approximately the 95 % confidence level using a coverage factor of k=2.

Item	Uncertainty
Vertically polarized radiated disturbances from 30MHz~1GHz in a semi-anechoic chamber at a distance of 3m	5.2 dB
Horizontally polarized radiated disturbances from 30MHz~1GHz in a semi-anechoic chamber at a distance of 3m	5.28 dB
Vertically polarized Radiated disturbances from 1GHz~18GHz in a semi-anechoic chamber at a distance of 3m	4.29 dB
Horizontally polarized Radiated disturbances from 1GHz~18GHz in a semi-anechoic chamber at a distance of 3m	4.29 dB
Vertically polarized Radiated disturbances from 18GHz~26.5GHz in a semi-anechoic chamber at a distance of 1m	2.45 dB
Horizontally polarized Radiated disturbances from 18GHz~26.5GHz in a semi-anechoic chamber at a distance of 1m	2.45 dB
Radiated disturbances from 9kHz~30MHz in a semi-anechoic chamber at a distance of 3m	2.99 dB
Emission on the Band Edge Test	4.29 dB
Minimum 6 dB Bandwidth	7.69 %
Maximum Peak Conducted Output Power	0.37 dB
Power Spectral Density	1.15 dB
Emissions In Non-Restricted Frequency Bands	1.15 dB
AC Power Line Conducted Emission	2.59 dB