



Manual

NÜO FLUX
41762 | 42039

GENERAL FEATURES

NÜO FLUX (ref. no.: 42039 and 41762)

- Maximum security proximity reader for 13.56 MHz contactless MIFARE® Plus, MIFARE® DESFire EV1, MIFARE® Classic and MIFARE Ultralight® cards.
- Reader status indicated via acoustic-light display.
- Communication encrypted with AES AND 3DES encryption algorithms.
- IP65 protection.
- Operating temperature from -20 °C to 50 °C for indoor and outdoor installations.
- References according to black and white model:
 - White: 42039
 - Black: 41762



NÜO FLUX
41762
42039

REGULATIONS

ISO/IEC 14443 A and B.

AES128 NIST FIPS PUB 197 MIFARE Plus EAL4+ Common Criteria certification.

NFC MIFARE emulation compliant.

EN 60950-1 2001 and A1: 2004.

EN 300 330-2 v1.3.1.





TECHNICAL SPECIFICATIONS

NÜO FLUX:

| | |
|-----------------------|---|
| INPUT VOLTAGE | 24VDC (11 - 28 VDC) |
| POWER | 1.8 W |
| CPU | 32-bit ARM Microprocessor |
| READING DISTANCE | 5 - 8 cm |
| MAXIMUM POWER | 250 mA |
| COMMUNICATIONS | 2 twisted pairs. Baud rate: 38400 Protocol: High security communications |
| CONNECTION | 60 cm of 5 mm diameter cable with 6 wires is provided |
| INPUTS | 1 Door sensor input (Detection resistance: <20 Ω) |
| OUTPUTS | 1 lock control output with 24 VDC power supply (250 mA maximum) |
| ALARM | 2 sound levels incorporated for granted access and denied access |
| ILLUMINATION | Automatically regulated according to environmental conditions. Colours according to status: <ul style="list-style-type: none"> - Red/White: Terminal offline. - Degraded Red/Pink: Terminal in card enrolment mode. - Flashing blue: Terminal in firmware update mode. - Blue: Terminal on standby. - Green: Access granted. - Red: Access denied. - White: Card writing operation. |
| MATERIALS | Manufactured with the highest quality polycarbonate with scratch-resistant unbreakable glass polycarbonate facing |
| INSTALLATION | Flush installation for indoor or outdoor use |
| PROTECTION LEVEL | IP65 |
| OPERATING TEMPERATURE | -20 °C to 50 °C |

| TECHNICAL SPECIFICATIONS | |
|--------------------------------------|---|
| READER DIMENSIONS | 92 x 92 x 30 mm (height x width x depth) |
| READER DIMENSIONS WITH EMBEDDED CASE | 92 x 92 x 57 mm (height x width x depth) |
| EMBEDDED CASE DIMENSIONS | 82 x 82 x 52 mm (height x width x depth) |
| ACCESSORIES | <ul style="list-style-type: none"> - Embedded case - Suction cup to remove front glass panel - Bag with accessories: <ul style="list-style-type: none"> - Screws to fasten reader to the embedded case. - Screws, washers and nuts for surface mounting. - 3 metres of piped cable with 4 wires (2 twisted pairs) and a female connector |

Installation >> NÜO FLUX >

TYPE OF WIRING AND WIRING DISTANCE:

The NÜO FLUX readers incorporates a 4-pin male overhead connector and the corresponding female connector which joins 3 metres of piped cable with 4 wires (2 twisted pairs). This means that the installation and wiring to then connect the reader to a single door controller or to the corresponding Wili are both very simple.

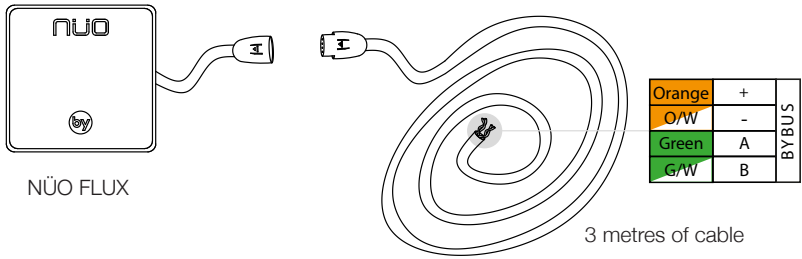

The wiring distance from the reader and the single door controller or Wili should not exceed 15 metres in length.

WIRING SPECIFICATIONS:

The built-in piped cable used to connect the reader has the following technical characteristics:

- Gauge: 0.22 mm
- Arrangement: 2 twisted pairs
- Resistance: <2 Ohms

DISTANCE BETWEEN READERS:

A minimum distance of 12 cm must be maintained if installations are made with doors with 2 input/output readers or with 2 readers that are very close together.



The NÜO FLUX reader can be flush mounted in various environments. The various installation methods are described below, covering built walls, plasterboard walls, and integration into other equipment such as turnstiles or gates:

1. Installation on working surfaces:

1) Using a level, make a hole in the wall for the rear case measuring 82 x 82 mm and 52 mm deep. Do not forget to pass the reader cable through.

Grout the hole with plaster and place the rear case in the hole.

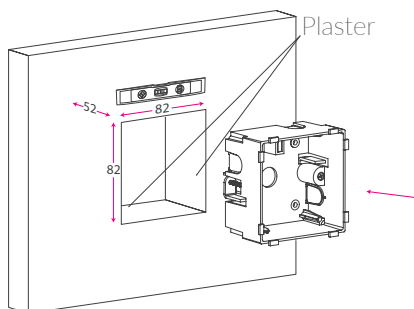

**Place the magnet at the top. This magnet will work as a tamper.
Recommended height for installation is between 1.2 and 1.5 m.**

2) Remove the NÜO FLUX reader front glass panel using the suction cup supplied. Place the suction cup in a corner for ease of operation.

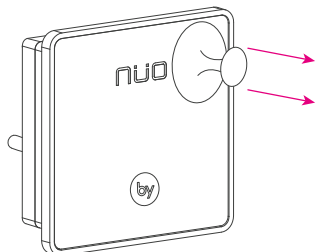

3) Pass the cable through the opening made and attach the reader to the rear case using the screws supplied as shown in the drawing. Finally, replace the front glass panel.

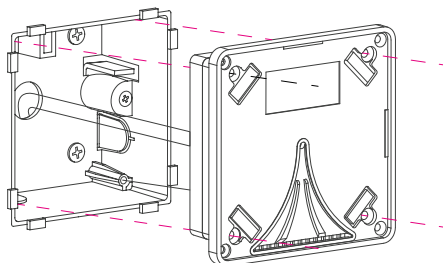

2. Installation on plasterboard walls 10 to 22 mm thick:

1) Using a level, make a hole in the wall for the rear case measuring 82 x 82 mm. Do not forget to pass the power and communication cables through.

2) Place the case in the hole and screw the pressure tabs to fix the case to the wall. These tabs apply pressure against the wall as the screws are turned.

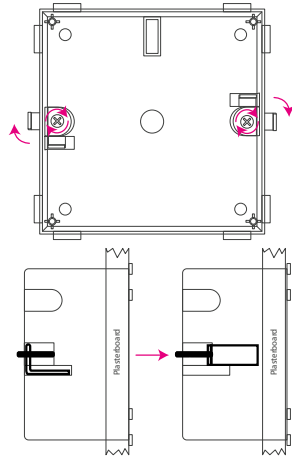
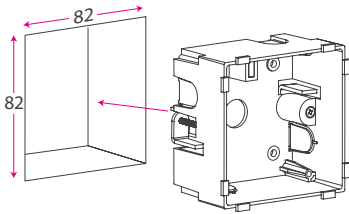

Place the magnet at the top. This magnet will work as a tamper. Recommended height for installation is between 1.2 and 1.5 m.

3) Remove the NÜO FLUX reader front glass panel using the suction cup supplied. Place the suction cup in a corner for ease of operation.

4) Pass the cable through the opening made and attach the reader to the rear case using the screws supplied as shown in the drawing. Finally, replace the front glass panel.:

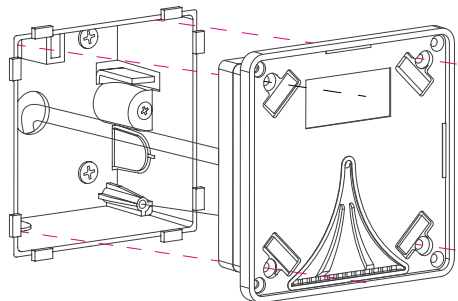
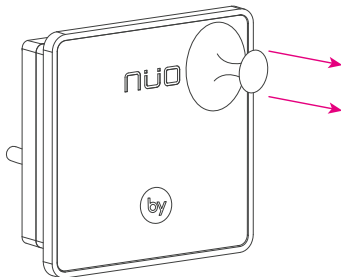

3. Installation in other environments:

1) Using a level, create a niche on the surface where the reader is to be placed measuring 78 x 78 x 30 mm. Create 4 holes forming a square measuring 80 x 80 mm for M3 screws. You can use tapped holes in order to avoid having to use nuts.

2) Remove the NÜO FLUX reader front glass panel using the suction cup supplied. Place the suction cup in a corner for ease of operation.

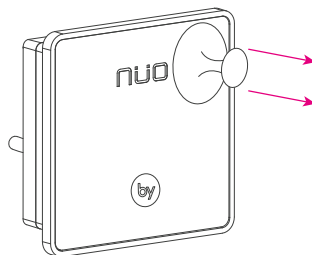
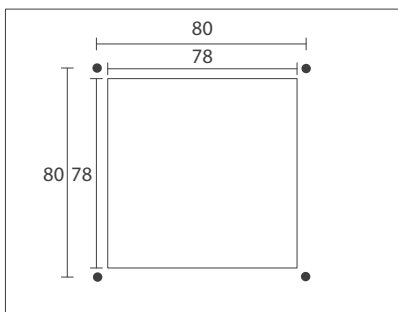

3) Place the reader in the hole and insert the screws in the holes located in the corners of the reader.

4) The equipment can be installed with the screws, nuts and washers supplied, or if tapped holes have been used then only the screws are required. Once secure, place the front glass panel to complete the installation.

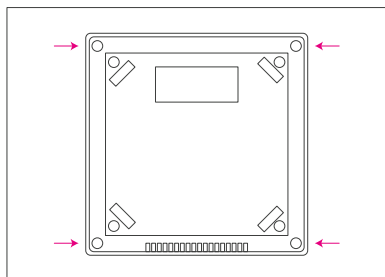

Assembly the equipment on outdoor or indoor surfaces that are free from vibrations. The wiring shall be suitably protected.

Installation >> Wiring

NÜO FLUX readers can be directly connected to two types of devices depending on facility architecture:

- Connection to a Willi.
- Connection to a single door controller.

The connection to be made for both types of devices is exactly the same. The colour code must be followed. For more detailed information, consult the equipment manuals referenced earlier.



Respect the specified input voltage.

READER WIRING:

| COLOUR | SIGNAL | BYBUS |
|--------------|----------|-------|
| Orange | + 24VDC | |
| Orange/White | 0V / GND | |
| Green | RS-485-A | |
| Green/White | RS-485-B | |



Install the reader using voltage-free power cables.



NÜO readers support an input voltage ranging from 11 to 28 VDC. 24 VDC is recommended in order to avoid possible voltage drops.



These signals must be perfectly isolated in order to prevent damaging the equipment or installation.

Changes or modifications not expressly approved by the party responsible for compliance could void the user's authority to operate the equipment.

Note: This equipment has been tested and found to comply with the limits for a Class B digital device, pursuant to part 15 of the FCC Rules. These limits are designed to provide reasonable protection against harmful interference in a residential installation. This equipment generates, uses and can radiate radio frequency energy and, if not installed and used in accordance with the instructions, may cause harmful interference to radio communications. However, there is no guarantee that interference will not occur in a particular installation. If this equipment does cause harmful interference to radio or television reception, which can be determined by turning the equipment off and on, the user is encouraged to try to correct the interference by one or more of the following measures:

- Reorient or relocate the receiving antenna.
- Increase the separation between the equipment and receiver.
- Connect the equipment into an outlet on a circuit different from that to which the receiver is connected.
- Consult the dealer or an experienced radio/TV technician for help.