



TEST REPORT

APPLICANT : Shenzhen Jaguar Wave Technology LTD
PRODUCT NAME : Wireless Gigabit Mobile Hotspot
MODEL NAME : JW-MRD-6001
BRAND NAME : JAGUAR WAVE
FCC ID : 2ARPAJW-MRD-6001
STANDARD(S) : 47CFR 2.1093
: IEEE 1528-2013
RECEIPT DATE : 2019-08-02
TEST DATE : 2019-08-17 to 2019-08-24
ISSUE DATE : 2019-08-31

Edited by: Liang Yumei
Liang Yumei (Rapporteur)

Approved by: Peng Huarui
Peng Huarui (Supervisor)

NOTE: This document is issued by MORLAB, the test report shall not be reproduced except in full without prior written permission of the company. The test results apply only to the particular sample(s) tested and to the specific tests carried out which is available on request for validation and information confirmed at our website.





DIRECTORY

1	SAR Results Summary	5
2	Technical Information	6
2.1	Applicant and Manufacturer Information	6
2.2	Equipment Under Test (EUT) Description.....	6
2.3	Environment of Test Site.....	7
3	Introduction.....	8
3.1	Introduction	8
3.2	SAR Definition	8
4	RF Exposure Limits	9
5	Applied Reference Documents.....	9
6	SAR Measurement System	10
6.1	E-Field Probe	11
6.2	Data Acquisition Electronics (DAE).....	12
6.3	Robot.....	13
6.4	Measurement Server	13
6.5	Light Beam Unit.....	13
6.6	Phantom.....	14
6.7	Device Holder	14
6.8	Data storage and Evaluation	16
6.9	Test Equipment List.....	18
6.10	Tissue Simulating Liquids.....	19
7	SAR System Verification	22
8	EUT Testing Position.....	25
8.1	SAR Evaluations near the Mouth/Jaw Regions of the SAM Phantom	25
8.2	Body Worn Accessory Configurations	25
8.3	Hotspot Mode Exposure Position Conditions	27



9	Measurement Procedures	28
9.1	Spatial Peak SAR Evaluation	29
9.2	Power Reference Measurement	29
9.3	Area Scan Procedures	29
9.4	Zoom Scan Procedures	30
9.5	SAR Averaged Methods	30
9.6	Power Drift Monitoring	30
10	Conducted RF Output Power	31
11	LTE Carrier Aggregation	54
12	Exposure Positions Consideration	56
12.1	EUT Antenna Location	56
12.2	Test Positions Consideration	56
13	Block diagram of the tests to be performed	57
13.1	Head	57
13.2	Body	58
14	Test Guidance	59
15	SAR Test Results Summary	60
15.1	Standalone Body SAR	60
16	Multi-Band Simultaneous Transmission Considerations	64
16.1	SAR Simultaneous Transmission Analysis	65
17	Measurement Uncertainty	69
18	Measurement Conclusion	71
	Annex A General Information	
	Annex B Test Setup Photos	
	Annex C Plots of System Performance Check	
	Annex D Plots of Maximum SAR Test Results	
	Annex E DASY Calibration Certificate	



Change History		
Version	Date	Description
1.0	2019-08-31	Original



1 SAR Results Summary

The maximum results of Specific Absorption Rate (SAR) found during test as bellows:

<Highest Reported standalone SAR Summary>

Frequency Band		Highest SAR Summary
		1g SAR (W/kg) Body (Separation 10mm)
WCDMA	GSM850	0.805
	GSM1900	0.691
LTE	LTE Band 5	0.778
	LTE Band 7	0.865
	LTE Band 38	0.438
	LTE Band 40	0.641
	LTE Band 41	0.520
WLAN	2.4GHz WLAN	0.100
	5GHz WLAN	0.898

Max Scaled SAR _{1g} (W/Kg):	Body:	0.898 W/kg	Limit(W/kg): 1.6 W/kg
--------------------------------------	-------	------------	-----------------------

Highest Simultaneous Transmission SAR _{1g} (W/Kg):	1.585 W/kg	Limit(W/kg): 1.6 W/kg
---	------------	-----------------------

Note:

1. The highest simultaneous transmission is scalar summation of Reported standalone SAR per FCC KDB 690783 D01 v01r03, and scalar SAR summation of all possible simultaneous transmission scenarios are < 1.6W/kg.
2. This device is compliance with Specific Absorption Rate (SAR) for general population/uncontrolled exposure limits (1.6 W/kg) specified in FCC 47 CFR part 2 (2.1093) and ANSI/IEEE C95.1-2005, and had been tested in accordance with the measurement methods and procedures specified in IEEE 1528-2013.



2 Technical Information

Note: Provide by Applicant.

2.1 Applicant and Manufacturer Information

Applicant:	Shenzhen Jaguar Wave Technology LTD
Applicant Address:	Unit 1002/1003, Block 2A, Tongtai Times Center, No.6259 Baoan Road, Fuhai Street, Baoan District, Shenzhen City, P.R.China
Manufacturer:	Shenzhen Jaguar Wave Technology LTD
Manufacturer Address:	Unit 1002/1003, Block 2A, Tongtai Times Center, No.6259 Baoan Road, Fuhai Street, Baoan District, Shenzhen City, P.R.China

2.2 Equipment Under Test (EUT) Description

EUT Name:	Wireless Gigabit Mobile Hotspot
Hardware Version:	P1
Software Version:	1.0.201810120116
Frequency Bands:	WCDMA Band II: 1850 MHz ~1910 MHz WCDMA Band V: 824 MHz ~ 849 MHz LTE Band 5: 824MHz ~ 849MHz LTE Band 7: 2500 MHz ~ 2570 MHz LTE Band 38: 2570 MHz ~ 2620MHz LTE Band 40A: 2305 MHz ~ 2315 MHz LTE Band 40B: 2350 MHz ~ 2360 MHz LTE Band 41: 2535 MHz ~ 2655 MHz WLAN 2.4GHz: 2412 MHz ~ 2462 MHz WLAN 5.2GHz: 5180 MHz ~ 5240 MHz WLAN 5.8GHz: 5745 MHz ~ 5825 MHz
Modulation Mode:	WCDMA: QPSK/16QAM LTE: QPSK/16QAM/64QAM 802.11b: DSSS 802.11a/g/n-HT20/HT40/ac-VHT20/ac-VHT40:OFDM
Hotspot Mode:	Support
Antenna Type:	PIFA Antenna
SIM cards description:	Only single SIM cards
LTE Carrier Aggregation Combinations	CA Downlink only: 7A, 7C, 38C, 41C

Note: For a more detailed description, please refer to specification or user's manual supplied by the applicant and/or manufacturer.



2.3 Environment of Test Site

Temperature:	20 ... 25 ° C
Humidity:	30 ... 75 %
Atmospheric Pressure:	980 ... 1020 hPa
Test frequency:	WCDMA Band II/V; FDD-LTE Band 5/7; TDD-LTE Band 38/40/41; WLAN 2.4GHz; WLAN 5GHz;
Operation mode:	Call established
Power Level:	WCDMA Band II/V(All Up Bits) FDD-LTE Band 5/7 (Maximum output power) TDD-LTE Band 38/40/41 (Maximum output power); WLAN 2.4GHz (Maximum output power); WLAN 5GHz (Maximum output power)

During SAR test, EUT is in Traffic Mode (Channel Allocated) at Normal Voltage Condition. A communication link is set up with a System Simulator (SS) by air link, and a call is established.

The EUT shall use its internal transmitter. The antenna(s), battery and accessories shall be those specified by the Factory. The EUT battery must be fully charged and checked periodically during the test to ascertain uniform power output. If a wireless link is used, the antenna connected to the output of the base station simulator shall be placed at least 50 cm away from the handset.

The signal transmitted by the simulator to the antenna feeding point shall be lower than the output power level of the handset by at least 35 dB.



3 Introduction

3.1 Introduction

SAR is related to the rate at which energy is absorbed per unit mass in an object exposed to a radio field. The SAR distribution in a biological body is complicated and is usually carried out by experimental techniques or numerical modeling. The standard recommends limits for two tiers of groups, occupational/controlled and general population/uncontrolled, based on a person's awareness and ability to exercise control over his or her exposure. In general, occupational/controlled exposure limits are higher than the limits for general population/uncontrolled.

3.2 SAR Definition

The SAR definition is the time derivative (rate) of the incremental energy (dW) absorbed by (dissipated in) an incremental mass (dm) contained in a volume element (dv) of a given density (ρ). The equation description is as below:

$$\text{SAR} = \frac{d}{dt} \left(\frac{dU}{dm} \right) = \frac{d}{dt} \left(\frac{dU}{\rho dv} \right)$$

SAR is expressed in units of Watts per kilogram (W/kg)

SAR measurement can be either related to the temperature elevation in tissue by

$$\text{SAR} = C \left(\frac{\delta T}{\delta t} \right)$$

Where: C is the specific heat capacity, δT is the temperature rise and δt is the exposure duration, or related to the electrical field in the tissue by

$$\text{SAR} = \frac{\sigma \cdot E^2}{\rho}$$

Where: σ is the conductivity of the tissue, ρ is the mass density of the tissue and E is the RMS electrical field strength. However for evaluating SAR of low power transmitter, electrical field measurement is typically applied.



4 RF Exposure Limits

Limits for General Population/Uncontrolled Exposure (W/kg)

Type Exposure	Uncontrolled Environment Limit
Spatial Peak SAR (1g cube tissue for head and trunk)	1.60W/kg
Spatial Peak SAR (10g cube tissue for limbs)	4.00W/kg
Spatial Peak SAR (1g cube tissue for whole body)	0.08W/kg

Note:

1. This limit is according to recommendation 1999/519/EC, Annex II (Basic Restrictions)
2. Occupational/Uncontrolled Environments are defined as locations where there is exposure that may be incurred by people who are aware of the potential for exposure, (i.e. as a result of employment or occupation)

5 Applied Reference Documents

Leading reference documents for testing:

No.	Identity	Document Title	Method determination /Remark
1	47 CFR§2.1093	Radio Frequency Radiation Exposure Evaluation: Portable Devices	No deviation
2	IEEE 1528-2013	IEEE Recommended Practice for Determining the Peak Spatial-Average Specific Absorption Rate (SAR) in the Human Head from Wireless Communications Devices: Measurement Techniques	No deviation
3	KDB 447498 D01v06	General RF Exposure Guidance	No deviation
4	KDB 248227 D01v02r02	SAR Measurement Procedures for 802.11 Transmitters	No deviation
5	KDB 865664 D01v01r04	SAR Measurement 100 MHz to 6 GHz	No deviation
6	KDB 865664 D02v01r02	RF Exposure Reporting	No deviation
7	KDB 648474 D04v01r03	Handset SAR	No deviation
8	KDB 941225 D01v03r01	3G SAR MEAUREMENT PROCEDURES	No deviation
9	KDB 941225 D05v02r05	SAR Evaluation Consideration for LTE Devices	No deviation
10	KDB 941225 D06v02r01	SAR Evaluation Procedures For Portable Devices With Wireless Router Capabilities	No deviation

6 SAR Measurement System

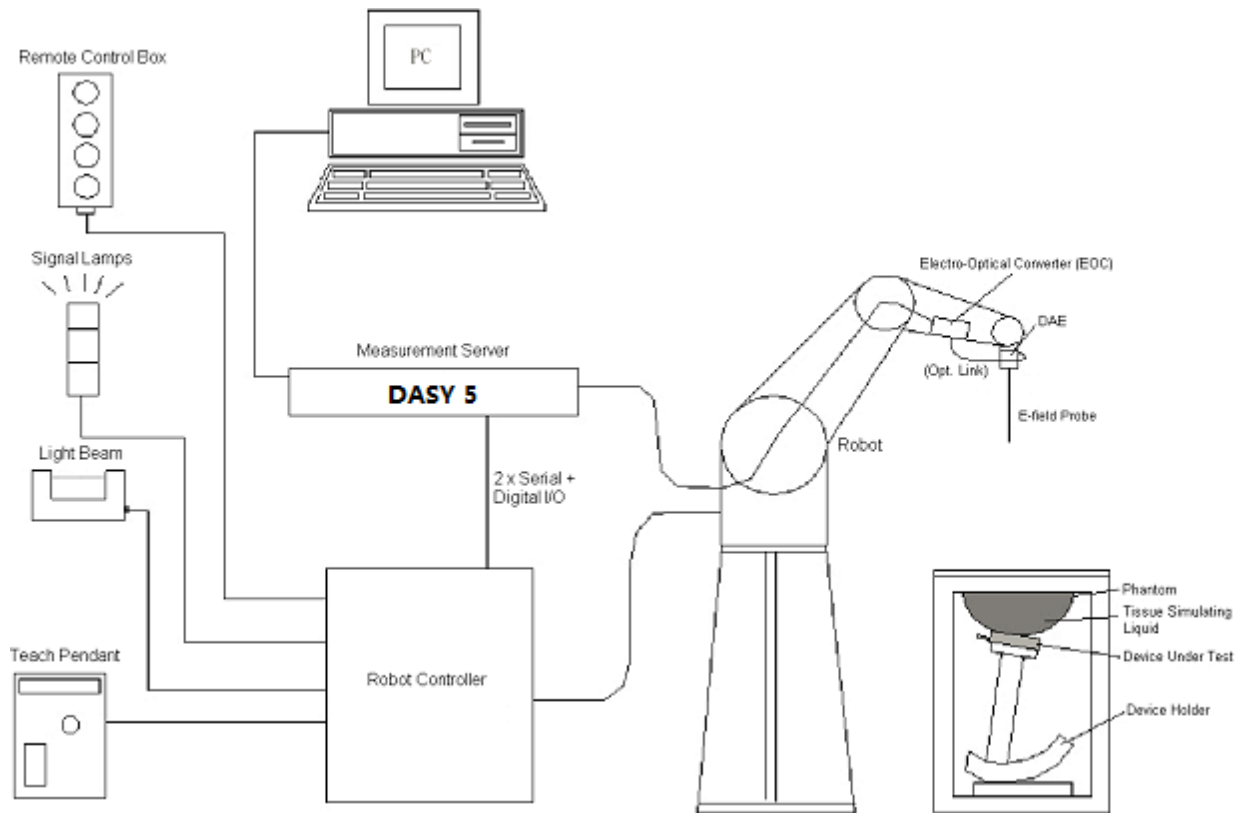

Fig.6.1 SPEAG DASY System Configurations

The DASY system for performance compliance tests is illustrated above graphically. This system consists of the following items:

- A standard high precision 6-axis robot with controller, a teach pendant and software
- A data acquisition electronic (DAE) attached to the robot arm extension
- A dosimetric probe equipped with an optical surface detector system
- The electro-optical converter (EOC) performs the conversion between optical and electrical signals
- A measurement server performs the time critical tasks such as signal filtering, control of the robot operation and fast movement interrupts.
- A probe alignment unit which improves the accuracy of the probe positioning
- A computer operating Windows XP
- DASY software
- Remote control with teach pendant and additional circuitry for robot safety such as warning lamps, etc.
- The SAM twin phantom

- A device holder
- Tissue simulating liquid
- Dipole for evaluating the proper functioning of the system

Component details are described in the following sub-sections.

6.1 E-Field Probe

The SAR measurement is conducted with the dosimetric probe (manufactured by SPEAG). The probe is specially designed and calibrated for use in liquid with high permittivity. The dosimetric probe has special calibration in liquid at different frequency. This probe has a built in optical surface detection system to prevent from collision with phantom.

➤ E-Field Probe Specification

<EX3DV4 Probe>

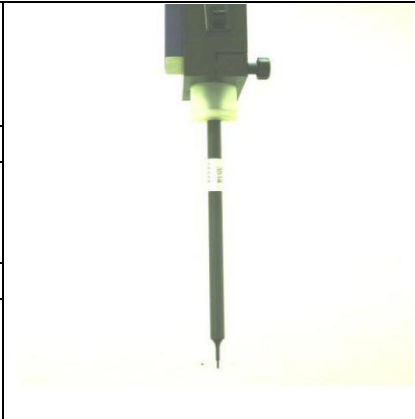
Construction	Symmetrical design with triangular core Built-in shielding against static charges PEEK enclosure material (resistant to organic solvents, e.g., DGBE)	
Frequency	10 MHz to 6 GHz; Linearity: ± 0.2 dB	
Directivity	± 0.3 dB in HSL (rotation around probe axis) ± 0.5 dB in tissue material (rotation normal to probe axis)	
Dynamic Range	10 μ W/g to 100 mW/g; Linearity: ± 0.2 dB	
Dimensions	Overall length: 330 mm (Tip: 20 mm) Tip diameter: 2.5 mm (Body: 12 mm) Typical distance from probe tip to dipole centers: 1 mm	

➤ E-Field Probe Calibration

Each probe needs to be calibrated according to a dosimetric assessment procedure with accuracy better than $\pm 10\%$. The spherical isotropy shall be evaluated and within ± 0.25 dB. The sensitivity parameters (Norm X, Norm Y and Norm Z), the diode compression parameter (DCP) and the conversion factor (ConvF) of the probe are tested. The calibration data can be referred to appendix E of this report.

6.2 Data Acquisition Electronics (DAE)

The Data acquisition electronics (DAE) consists of a highly sensitive electrometer-grade preamplifier with auto-zeroing, a channel and gain-switching multiplexer, a fast 16 bit AD-converter and a command decoder and control logic unit. Transmission to the measurement server is accomplished through an optical downlink for data and status information as well as an optical uplink for commands and the clock. The input impedance of the DAE is 200 MOhm; the inputs are symmetrical and floating. Common mode rejection is above 80 dB.

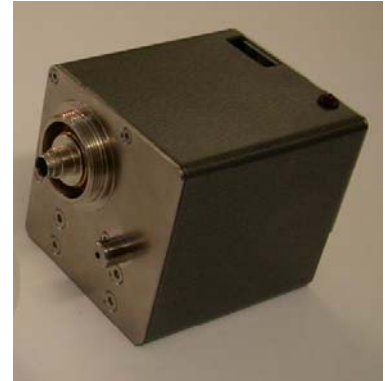

Fig. 6.2 Photo of DAE

6.3 Robot

The SPEAG DASY system uses the high precision robots (DASY5: TX60XL) type from Stäubli SA (France). For the 6-axis controller system, the robot controller version (DASY5: CS8c) from Stäubli is used. The Stäubli robot series have many features that are important for our application:

- High precision (repeat ability 0.02 mm)
- High reliability (industrial design)
- Low maintenance costs (virtually maintenance free due to direct drive gears; no belt drives)
- Jerk-free straight movements
- Low ELF interference (motor control fields shielded via the closed metallic construction shields)

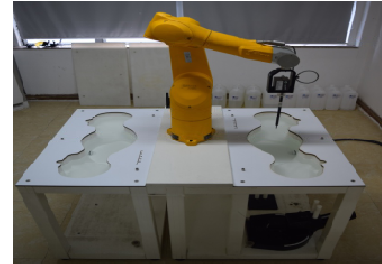

Fig. 6.3 Photo of Robot

6.4 Measurement Server

The measurement server is based on a PC/104 CPU board with CPU (DASY 5: 400MHz, Intel Celeron), chip-disk (DASY5: 128 MB), RAM (DASY5: 128 MB). The necessary circuits for communication with the DAE electronic box, as well as the 16 bit AD converter system for optical detection and digital I/O interface are contained on the DASY I/O board, which is directly connected to the PC/104 bus of the CPU board.

The measurement server performs all the real-time data evaluation for field measurements and surface detection, controls robot movements and handles safety operations.



Fig. 6.4 Photo of Server for DASY5

6.5 Light Beam Unit

The light beam switch allows automatic "tooling" of the probe. During the process, the actual position of the probe tip with respect to the robot arm is measured, as well as the probe length and the horizontal probe offset. The software then corrects all movements, such that the robot coordinates are valid for the probe tip.

The repeat ability of this process is better than 0.1 mm. If a position has been taught with an aligned probe, the same position will be reached with another aligned probe within 0.1 mm, even if the other probe has different dimensions. During probe rotations, the probe tip will keep its actual position.



Fig. 6.5 Photo of Light Beam

6.6 Phantom

<SAM Twin Phantom>

Shell Thickness	2 ± 0.2 mm (sagging: <1%) Center ear point: 6 ± 0.2 mm
Filling Volume Dimensions	Approx. 25 liters Length: 1000 mm; Width: 500 mm; Height: adjustable feet
Measurement Areas	Left Head, Right Head, Flat phantom

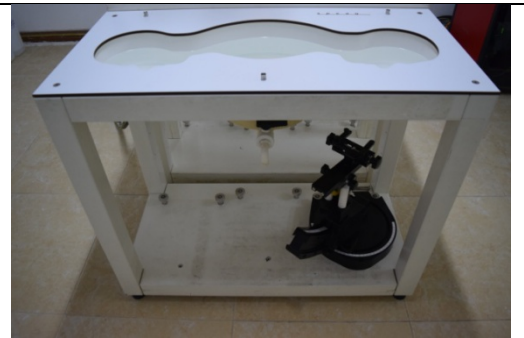

Fig. 6.6Photo of SAM Phantom

The bottom plate contains three pair of bolts for locking the device holder. The device holder positions are adjusted to the standard measurement positions in the three sections. A white cover is provided to tap the phantom during off-periods to prevent water evaporation and changes in the liquid parameters. On the phantom top, three reference markers are provided to identify the phantom position with respect to the robot.

6.7 Device Holder

<Device Holder for SAM Twin Phantom>

The SAR in the phantom is approximately inversely proportional to the square of the distance between the source and the liquid surface. For a source at 5 mm distance, a positioning uncertainty of ±0.5 mm would produce a SAR uncertainty of ± 20 %. Accurate device positioning is therefore crucial for accurate and repeatable measurements. The positions in which the devices must be measured are defined by the standards.

The DASY device holder is designed to cope with different positions given in the standard. It has two scales for the device rotation (with respect to the body axis) and the device inclination (with respect to the line between the ear reference points). The rotation center for both scales is the ear reference point (ERP).

Thus the device needs no repositioning when changing the angles.

The DASY device holder is constructed of low-loss POM material having the following dielectric parameters: relative permittivity $\epsilon = 3$ and loss tangent $\delta = 0.02$. The amount of dielectric material has been reduced in the closest vicinity of the device, since measurements have suggested that the influence of the clamp on the test results could thus be lowered.



Fig. 6.7 Photo of Device Holder

<Laptop Extension Kit>

The extension is lightweight and made of POM, acrylic glass and foam. It fits easily on the upper part of the mounting device in place of the phone positioned. The extension is fully compatible with the SAM Twin and ELI phantoms.

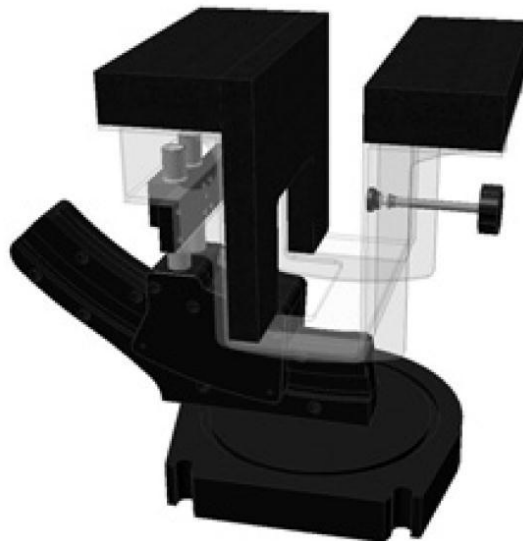

Fig 6.8 Laptop Extension Kit



6.8 Data storage and Evaluation

➤ Data Storage

The DASY software stores the assessed data from the data acquisition electronics as raw data (in microvolt readings from the probe sensors), together with all the necessary software parameters for the data evaluation (probe calibration data, liquid parameters and device frequency and modulation data) in measurement files. The post-processing software evaluates the desired unit and format for output each time the data is visualized or exported. This allows verifications of the complete software setup even after the measurement and allows correction of erroneous parameter settings. For example, if a measurement has been performed with an incorrect crest factor parameter in the device setup, the parameter can be corrected afterwards and the data can be reevaluated.

The measured data can be visualized or exported in different units or formats, depending on the selected probe type (e.g., [V/m], [mW/g]). Some of these units are not available in certain situations or give meaningless results, e.g., a SAR-output in a non-loss media, will always be zero. Raw data can also be exported to perform the evaluation with other software packages.

➤ Data Evaluation

The DASY post-processing software (SEMCAD) automatically executes the following procedures to calculate the field units from the microvolt readings at the probe connector. The parameters used in the evaluation are stored in the configuration modules of the software:

Probe Parameters:	- Sensitivity	Norm _i , a _{i0} , a _{i1} , a _{i2}
	- Conversion	ConvF _i
	- Diode compression point	dcp _i
Device Parameters:	- Frequency	f
	- Crest	cf
Media Parameters:	- Conductivity	σ
	- Density	ρ

These parameters must be set correctly in the software. They can be found in the component documents or they can be imported into the software from the configuration files issued for the DASY components. In the direct measuring mode of the multi-meter option, the parameters of the actual system setup are used. In the scan visualization and export modes, the parameters stored in the corresponding document files are used.

The first step of the evaluation is a linearization of the filtered input signal to account for the compression characteristics of the detector diode. The compensation depends on the input signal, the diode type and the DC-transmission factor from the diode to the evaluation electronics. If the exciting field is pulsed, the crest factor of the signal must be known to correctly compensate for peak power.



The formula for each channel can be given as:

$$V_i = U_i + U_i^2 \cdot \frac{cf}{dcp_i}$$

With V_i = compensated signal of channel i, (i = x, y, z)

U_i = input signal of channel i, (i = x, y, z)

cf = crest factor of exciting field (DASY parameter)

dcp_i = diode compression point (DASY parameter)

From the compensated input signals, the primary field data for each channel can be evaluated:

$$\text{E- Field Probes: } E_i = \sqrt{\frac{v_i}{\text{Norm}_i \cdot \text{ConvF}}}$$

$$\text{H-Field Probes: } H_i = \sqrt{V_i} \cdot \frac{a_{i0} + a_{i1}f + a_{i2}f^2}{f}$$

With V_i = compensated signal of channel i, (i = x, y, z)

Norm_i = sensor sensitivity of channel i, (i = x, y, z), $\mu V / (V/m)^2$

ConvF = sensitivity enhancement in solution

a_{ij} = sensor sensitivity factors for H-field probes

f = carrier frequency (GHz)

E_i = electric field strength of channel i in V/m

H_i = magnetic field strength of channel i in A/m

The RSS value of the field components gives the total field strength (Hermitian magnitude):

$$E_{\text{tot}} = \sqrt{E_x^2 + E_y^2 + E_z^2}$$

The primary field data are used to calculate the derived field units.

$$\text{SAR} = E_{\text{tot}}^2 \cdot \frac{\sigma}{\rho \cdot 1000}$$

With SAR = local specific absorption rate in mW/g

E_{tot} = total field strength in V/m

σ = conductivity in (mho/m) or (Siemens/m)

ρ = equipment tissue density in g/cm^3

Note that the density is set to 1, to account for actual head tissue density rather than the density of the tissue simulating liquid.



6.9 Test Equipment List

Manufacturer	Name of Equipment	Type/Model	Serial Number	Calibration	
				Last Cal.	Due Date
SPEAG	835MHz System Validation Kit	D835V2	4d227	2019.06.22	2020.06.21
SPEAG	1900MHz System Validation Kit	D1900V2	5d221	2019.06.22	2020.06.21
SPEAG	2300MHz System Validation Kit	D2300V2	1056	2018.09.18	2019.09.17
SPEAG	2450MHz System Validation Kit	D2450V2	805	2018.10.26	2019.10.25
SPEAG	2600MHz System Validation Kit	D2600V2	1139	2019.06.25	2020.06.24
SPEAG	Dosimetric E-Field Probe	EX3DV4	3823	2018.11.12	2019.11.11
SPEAG	Data Acquisition Electronics	DAE4	480	2019.04.11	2020.04.10
SPEAG	Dielectric Assessment KIT	DAK-3.5	1279	2018.11.03	2019.11.02
SPEAG	SAM Twin Phantom 1	QD 000 P40 CB	TP-1471	NCR	NCR
SPEAG	SAM Twin Phantom 2	QD 000 P40 CB	TP-1464	NCR	NCR
SPEAG	Phone Positioner	N/A	N/A	NCR	NCR
R&S	Network Emulator	CMW500	124534	2019.04.17	2020.04.16
Agilent	Network Analyzer	E5071B	MY42404762	2019.04.15	2020.04.14
mini-circuits	Amplifier	ZHL-42W+	608501717	NCR	NCR
mini-circuits	Amplifier	ZVE-8G+	754401735	NCR	NCR
Agilent	Signal Generator	N5182B	MY53050509	2019.04.17	2020.04.16
Agilent	Power Sensor	N8482A	MY41090849	2018.11.23	2019.11.22
Agilent	Power Meter	E4416A	MY45102093	2018.11.23	2019.11.22
Anritsu	Power Sensor	MA2411B	N/A	2018.11.23	2019.11.22
Anritsu	Power Meter	NRVD	101066	2018.11.23	2019.11.22
MCL	Attenuation1	351-218-010	N/A	NA	NA
Agilent	Dual Directional Coupler	778D	50422	NA	NA
THERMOMETER	Thermo meter	DC-803	N/A	2018.11.22	2019.11.21
N/A	Tissue Simulating Liquids	800-6000MHz	N/A	24H	

Note:

1. The calibration certificate of DASY can be referred to appendix E of this report.
2. The Insertion Loss calibration of Dual Directional Coupler and Attenuator were characterized via the network analyzer and compensated during system check.
3. The dielectric probe kit was calibrated via the network analyzer, with the specified procedure (calibrated in pure water) and calibration kit (standard) short circuit, before the dielectric measurement. The specific procedure and calibration kit are provided by Speag.
4. In system check we need to monitor the level on the power meter, and adjust the power amplifier level

to have precise power level to the dipole; the measured SAR will be normalized to 1W input power according to the ratio of 1W to the input power to the dipole. For system check, the calibration of the power amplifier is deemed not critically required for correct measurement; the power meter is critical and we do have calibration for it

5. Attenuator insertion loss is calibrated by the network Analyzer, which the calibration is valid, before system check.
6. N.C.R means No Calibration Requirement.

6.10 Tissue Simulating Liquids

For the measurement of the field distribution inside the SAM phantom with DASY, the phantom must be filled with around 25 liters of homogeneous body tissue simulating liquid. For head SAR testing, the liquid height from the ear reference point (ERP) of the phantom to the liquid top surface is larger than 15 cm, which is shown in Fig. 6.11, for body SAR testing, the liquid height from the center of the flat phantom to liquid top surface is larger than 15 cm, which is shown in Fig. 6.12.



Fig 6.10 Photo of Liquid Height for Head SAR

Fig 6.11 Photo of Liquid Height for Body SAR

The following table gives the recipes for tissue simulating liquids

Frequency (MHz)	Water (%)	Sugar (%)	Cellulose (%)	Salt (%)	Preventol (%)	DGBE (%)	Conductivity (σ)	Permittivity (ϵ_r)
Head								
750	41.1	57.0	0.2	1.4	0.2	0	0.89	41.9
835	40.3	57.9	0.2	1.4	0.2	0	0.90	41.5
1800, 1900, 2000	55.2	0	0	0.3	0	44.5	1.40	40.0
2450	55.0	0	0	0	0	45.0	1.80	39.2
2600	54.8	0	0	0.1	0	45.1	1.96	39.0
Body								
750	51.7	47.2	0	0.9	0.1	0	0.96	55.5
835	50.8	48.2	0	0.9	0.1	0	0.97	55.2
1800, 1900, 2000	70.2	0	0	0.4	0	29.4	1.52	53.3
2450	68.6	0	0	0	0	31.4	1.96	52.7
2600	68.1	0	0	0.1	0	31.8	2.16	52.5



Simulating Liquid for 5GHz, Manufactured by SPEAG

Ingredients	(% by weight)
Water	64~78%
Mineral oil	11~18%
Emulsifiers	9~15%
Additives and Salt	2~3%

The relative permittivity and conductivity of the tissue material should be within±5% of the values given in the table below recommended by the FCC OET 65supplement C and RSS 102 Issue 5.

Target Frequency (MHz)	Head		Body	
	ϵ_r	σ (S/m)	ϵ_r	σ (S/m)
150	52.3	0.76	61.9	0.80
300	45.3	0.87	58.2	0.92
450	43.5	0.87	56.7	0.94
835	41.5	0.90	55.2	0.97
900	41.5	0.97	55.0	1.05
915	41.5	0.98	55.0	1.06
1450	40.5	1.20	54.0	1.30
1610	40.3	1.29	53.8	1.40
1800-2000	40.0	1.40	53.3	1.52
2450	39.2	1.80	52.7	1.95
3000	38.5	2.40	52.0	2.73
5800	35.3	5.27	48.2	6.00

(ϵ_r = relative permittivity, σ = conductivity and $\rho = 1000 \text{ kg/m}^3$)



The dielectric parameters of liquids were verified prior to the SAR evaluation using a Speag Dielectric Probe Kit and an Agilent Network Analyzer.

The following table shows the measuring results for simulating liquid.

Frequency (MHz)	Tissue Type	Liquid Temp. (°C)	Conductivity (σ)	Conductivity Target (σ)	Delta (σ) (%)	Limit (%)	Date
835	HSL	22.2	0.903	0.90	0.33	±5	2019.08.20
1900	HSL	22.6	1.375	1.40	-1.79	±5	2019.08.24
2300	HSL	22.3	1.680	1.67	0.60	±5	2019.08.18
2450	HSL	22.3	1.858	1.80	3.22	±5	2019.08.18
2600	HSL	22.1	2.036	1.96	3.88	±5	2019.08.17
5250	HSL	22.8	4.757	4.71	1.00	±5	2019.08.19
5750	HSL	22.8	5.374	5.22	2.95	±5	2019.08.19

Frequency (MHz)	Tissue Type	Liquid Temp. (°C)	Permittivity (ϵ_r)	Permittivity Target (ϵ_r)	Delta (ϵ_r) (%)	Limit (%)	Date
835	HSL	22.2	41.135	41.50	-0.88	±5	2019.08.20
1900	HSL	22.6	39.998	40.00	-0.01	±5	2019.08.24
2300	HSL	22.3	40.616	39.50	2.83	±5	2019.08.18
2450	HSL	22.3	39.975	39.20	1.98	±5	2019.08.18
2600	HSL	22.1	39.303	39.00	0.78	±5	2019.08.17
5250	HSL	22.8	36.931	35.95	2.73	±5	2019.08.19
5750	HSL	22.8	35.896	35.35	1.54	±5	2019.08.19

Note: Effective February 19, 2019, FCC has permitted the use of single head-tissue simulating liquid specified in IEC 62209-1 for all SAR tests.

7 SAR System Verification

Each DASY system is equipped with one or more system validation kits. These units, together with the predefined measurement procedures within the DASY software, enable the user to conduct the system performance check and system validation. System validation kit includes a dipole, tripod holder to fix it underneath the flat phantom and a corresponding distance holder.

➤ Purpose of System Performance check

The system performance check verifies that the system operates within its specifications. System and operator errors can be detected and corrected. It is recommended that the system performance check be performed prior to any usage of the system in order to guarantee reproducible results. The system performance check uses normal SAR measurements in a simplified setup with a well characterized source. This setup was selected to give a high sensitivity to all parameters that might fail or vary over time. The system check does not intend to replace the calibration of the components, but indicates situations where the system uncertainty is exceeded due to drift or failure.

➤ System Setup

In the simplified setup for system evaluation, the EUT is replaced by a calibrated dipole and the power source is replaced by a continuous wave that comes from a signal generator. The calibrated dipole must be placed beneath the flat phantom section of the SAM twin phantom with the correct distance holder. The distance holder should touch the phantom surface with a light pressure at the reference marking and be oriented parallel to the long side of the phantom. The equipment setup is shown below:



Fig 7.1 Photo of Dipole Setup

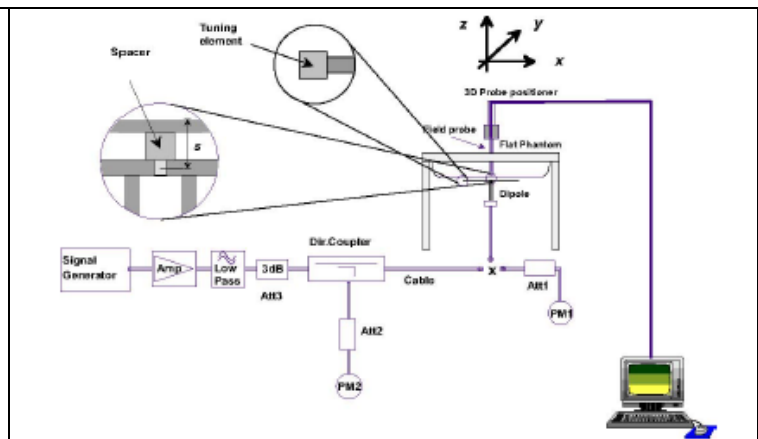

Fig 7.2 System Setup for System Evaluation



➤ **System Verification Results**

Comparing to the original SAR value provided by SPEAG, the verification data should be within its specification of 10%. Below table shows the target SAR and measured SAR after normalized to 1W input power. The table as below indicates the system performance check can meet the variation criterion and the plots can be referred to Appendix C of this report.

Dipole S/N	Probe S/N	DAE S/N
D835V2-4d227	3823	480
D1900V2_5d221	3823	480
D2300V2-1056	3823	480
D2450V2-805	3823	480
D2600V2-1139	3823	480
D5GHzV2-1176-5250	3823	480
D5GHzV2-1176-5750	3823	480

<1g SAR>

Date	Freq. (MHz)	Tissue Type	Input Power (mW)	Measured 1g SAR (W/kg)	Targeted 1g SAR (W/kg)	Normalized 1g SAR (W/kg)	Deviation (%)
2019.08.20	835	HSL	250	2.31	9.34	9.24	-1.07
2019.08.24	1900	HSL	250	9.57	39.50	38.28	-3.09
2019.08.18	2300	HSL	250	12.50	47.70	50	4.82
2019.08.18	2450	HSL	250	13.30	52.00	53.2	2.31
2019.08.17	2600	HSL	250	14.30	54.00	57.2	5.93
2019.08.19	5250	HSL	100	8.05	78.90	80.5	2.03
2019.08.19	5750	HSL	100	7.87	80.00	78.7	-1.63
2019.08.20	835	MSL	250	2.46	9.61	9.84	2.39
2019.08.24	1900	MSL	250	9.94	39.90	39.76	-0.35
2019.08.19	2300	MSL	250	12.13	47.90	48.52	1.29
2019.08.18	2450	MSL	250	12.70	50.50	50.8	0.59
2019.08.17	2600	MSL	250	13.40	54.00	53.6	-0.74
2019.08.19	5250	MSL	100	7.60	72.70	76	4.54
2019.08.19	5750	MSL	100	7.77	75.30	77.7	3.19



<10g SAR>

Date	Freq. (MHz)	Tissue Type	Input Power (mW)	Measured 10g SAR (W/kg)	Targeted 10g SAR (W/kg)	Normalized 10g SAR (W/kg)	Deviation (%)
2019.08.20	835	HSL	250	1.56	6.07	6.24	2.80
2019.08.24	1900	HSL	250	4.94	20.60	19.76	-4.08
2019.08.18	2300	HSL	250	5.96	23.10	23.84	3.20
2019.08.18	2450	HSL	250	6.14	24.10	24.56	1.91
2019.08.17	2600	HSL	250	6.35	24.50	25.40	3.67
2019.08.19	5250	HSL	100	2.29	22.50	22.90	1.78
2019.08.19	5750	HSL	100	2.23	22.60	22.3	-1.33
2019.08.20	835	MSL	250	1.65	6.31	6.6	4.60
2019.08.24	1900	MSL	250	5.16	20.70	20.64	-0.29
2019.08.19	2300	MSL	250	6.02	23.00	24.08	4.70
2019.08.18	2450	MSL	250	5.74	23.50	22.96	-2.30
2019.08.17	2600	MSL	250	6.26	24.20	25.04	3.47
2019.08.19	5250	MSL	100	2.10	20.60	21.00	1.94
2019.08.19	5750	MSL	100	2.15	21.10	21.5	1.90

Note: System checks the specific test data please see Annex C

8 EUT Testing Position

This EUT was tested in ten different positions. They are Front/Back/Right Side/Top Side/Bottom Side of the EUT with phantom 10 mm gap, as illustrated below, please refer to Appendix B for the test setup photos.

8.1 SAR Evaluations near the Mouth/Jaw Regions of the SAM Phantom

Antennas located near the bottom of a phone may require SAR measurements around the mouth and jaw regions of the SAM head phantom. This typically applies to clam-shell style phones that are generally longer in the unfolded normal use positions or to certain older style long rectangular phones.

Under these circumstances, the following procedures apply, adopted from the FCC guidance on SAR handsets document FCC KDB Publication 648474 D04v01r03. The SAR required in these regions of SAM should be measured using a flat phantom. The phone should be positioned with a separation distance of 4 mm between the ear reference point (ERP) and the outer surface of the flat phantom shell. While maintaining this distance at the ERP location, the low (bottom) edge of the phone should be lowered from the phantom to establish the same separation distance between the peak SAR locations identified by the truncated partial SAR distribution measured with the SAM phantom. The distance from the peak SAR location to the phone is determined by the straight line passing perpendicularly through the phantom surface. When it is not feasible to maintain 4 mm separation at the ERP while also establishing the required separation at the peak SAR location, the top edge of the phone will be allowed to touch the phantom with a separation < 4 mm at the ERP. The phone should not be tilted to the left or right while placed in this inclined position to the flat phantom.

8.2 Body Worn Accessory Configurations

- To position the device parallel to the phantom surface with either keypad up or down.
- To adjust the device parallel to the flat phantom.
- To adjust the distance between the device surface and the flat phantom to 10 mm or holster surface and the flat phantom to 0 mm.

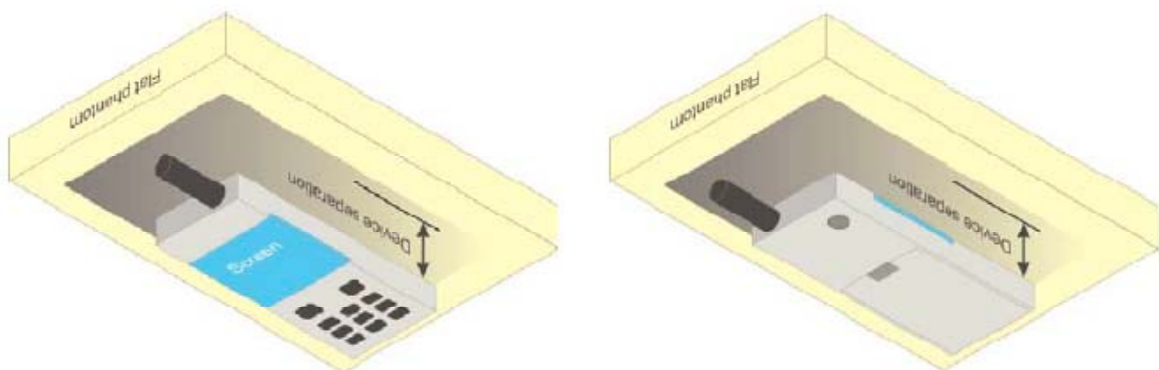



REPORT No.: SZ19070448S01

Fig.8.5 Illustration for Body Worn Position

8.3 Hotspot Mode Exposure Position Conditions

For handsets that support hotspot mode operations, with wireless router capabilities and various web browsing functions, the relevant hand and body exposure conditions are tested according to the hotspot SAR procedures in KDB 941225. A test separation distance of 10 mm is required between the phantom and all surfaces and edges with a transmitting antenna located within 25 mm from that surface or edge. When the form factor of a handset is smaller than 9 cm x 5 cm, a test separation distance of 5 mm (instead of 10 mm) is required for testing hotspot mode. When the separation distance required for body-worn accessory testing is larger than or equal to that tested for hotspot mode, in the same wireless mode and for the same surface of the phone, the hotspot mode SAR data may be used to support body-worn accessory SAR compliance for that particular configuration (surface).

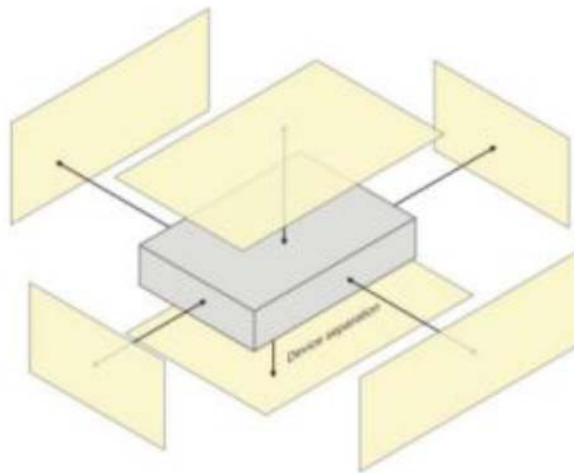

Fig 8.6 Illustration for Hotspot Position



9 Measurement Procedures

The measurement procedures are as follows:

<Conducted power measurement>

- For WWAN power measurement, use base station simulator to configure EUT WWAN transition in conducted connection with RF cable, at maximum power in each supported wireless interface and frequency band.
- Read the WWAN RF power level from the base station simulator.
- For WLAN/BT power measurement, use engineering software to configure EUT WLAN/BT continuously transmission, at maximum RF power in each supported wireless interface and frequency band.
- Connect EUT RF port through RF cable to the power meter or spectrum analyzer, and measure WLAN/BT output power.

<Conducted power measurement>

- Use base station simulator to configure EUT WWAN transmission in radiated connection, and engineering software to configure EUT WLAN/BT continuously transmission, at maximum RF power, in the highest power channel.
- Place the EUT in positions as Appendix B demonstrates.
- Set scan area, grid size and other setting on the DASY software.
- Measure SAR results for the highest power channel on each testing position.
- Find out the largest SAR result on these testing positions of each band.
- Measure SAR results for other channels in worst SAR testing position if the Reported SAR or highest power channel is larger than 0.8 W/kg.

According to the test standard, the recommended procedure for assessing the peak spatial-average SAR value consists of the following steps:

- Power reference measurement
- Area scan
- Zoom scan
- Power drift measurement



9.1 Spatial Peak SAR Evaluation

The procedure for spatial peak SAR evaluation has been implemented according to the test standard. It can be conducted for 1g and 10g, as well as for user-specific masses. The DASY software includes all numerical procedures necessary to evaluate the spatial peak SAR value.

The base for the evaluation is a “cube” measurement. The measured volume must include the 1g and 10 g cubes with the highest averaged SAR values. For that purpose, the center of the measured volume is aligned to the interpolated peak SAR value of a previously performed area scan.

The entire evaluation of the spatial peak values is performed within the post-processing engine (SEMCAD). The system always gives the maximum values for 1g and 10g cubes. The algorithm to find the cube with highest averaged SAR is divided into the following stages:

- Extraction of the measured data (grid and values) from the Zoom Scan.
- Calculation of the SAR value at every measurement point based on all stored data (A/D values and measurement parameters).
- Generation of a high-resolution mesh within the measured volume.
- Interpolation of all measured values from the measurement grid to the high-resolution grid
- Extrapolation of the entire 3-D field distribution to the phantom surface over the distance from sensor to surface
- Calculation of the averaged SAR within masses of 1g and 10g.

9.2 Power Reference Measurement

The Power Reference Measurement and Power Drift Measurement are for monitoring the power drift of the device under test in the batch process. The minimum distance of probe sensors to surface determines the closest measurement point to phantom surface. This distance cannot be smaller than the distance of sensor calibration points to probe tip as defined in the probe properties.

9.3 Area Scan Procedures

Area scans are defined prior to the measurement process being executed with a user defined variable spacing between each measurement point (integral) allowing low uncertainty measurements to be conducted. Scans defined for FCC applications utilize a 10mm² step integral, with 1mm interpolation used to locate the peak SAR area used for zoom scan assessments.

When an Area Scan has measured all reachable points, it computes the field maxima found in the scanned area, within a range of the global maximum. The range (in dB) is specified in the standards for compliance testing. For example, a 2 dB range is required in IEEE1528-2003, EN 50361 and IEC 62209 standards, whereby 3 dB is a requirement when compliance is assessed in accordance with the ARIB standard (Japan).



9.4 Zoom Scan Procedures

Zoom Scans are used to assess the peak spatial SAR values within a cubic averaging volume containing 1 g and 10 g of simulated tissue. A density of 1000 kg/m^3 is used to represent the head and body tissue density and not the phantom liquid density, in order to be consistent with the definition of the liquid dielectric properties, i.e. the side length of the 1g cube is 10mm, with the side length of the 10 g cube 21,5mm. The zoom scan integer steps can be user defined so as to reduce uncertainty, but normal practice for typical test applications utilize a physical step of 5x5x7 (8mmx8mmx5mm) providing a volume of 32mm in the X & Y axis, and 30mm in the Z axis.

9.5 SAR Averaged Methods

In DASYS, the interpolation and extrapolation are both based on the modified Quadratic Sheppard's method. The interpolation scheme combines a least-square fitted function method and a weighted average method which are the two basic types of computational interpolation and approximation.

Extrapolation routines are used to obtain SAR values between the lowest measurement points and the inner phantom surface. The extrapolation distance is determined by the surface detection distance and the probe sensor offset. The uncertainty increases with the extrapolation distance. To keep the uncertainty within 1% for the 1g and 10g cubes, the extrapolation distance should not be larger than 5 mm.

9.6 Power Drift Monitoring

All SAR testing is under the EUT install full charged battery and transmit maximum output power. In DASYS measurement software, the power reference measurement and power drift measurement procedures are used for monitoring the power drift of EUT during SAR test. Both these procedures measure the field at a specified reference position before and after the SAR testing. The software will calculate the field difference in dB. If the power drifts more than 5%, the SAR will be retested.



10 Conducted RF Output Power

➤ WCDMA Conducted Power

Summary of UMTS conducted power measurement:

1. The 3G SAR test reduction procedure is applied, when the maximum output power and tune-up tolerance specified for production units in a secondary mode is $\leq \frac{1}{4}$ dB higher than the primary mode, SAR measurement is not required for the secondary mode.
2. The following tests were conducted according to the test requirements outlines in 3GPP TS 34.121 specification.
3. The procedures in KDB 941225 D01v03r01 are applied for 3GPP Rel. 6 HSPA to configure the device in the required sub-test mode(s) to determine SAR test exclusion.
4. For HSPA+ devices supporting 16 QAM in the uplink, power measurements procedure is according to the configurations in Table C.11.1.4 of 3GPP TS 34.121-1.
5. Per KDB 941225 D01v03r01, RMC 12.2kbps setting is used to evaluate SAR. The maximum output power and tune-up tolerance specified for production units in HSDPA / HSUPA / DC-HSDPA / HSPA+ is $\leq \frac{1}{4}$ dB higher than RMC 12.2Kbps or when the highest reported SAR of the RMC12.2Kbps is scaled by the ratio of specified maximum output power and tune-up tolerance of HSDPA / HSUPA / DC-HSDPA / HSPA+ to RMC12.2Kbps and the adjusted SAR is ≤ 1.2 W/kg, SAR measurement is not required for HSDPA / HSUPA / DC-HSDPA / HSPA+, and according to the following RF output power, the output power results of the secondary modes (HSDPA / HSUPA / DC-HSDPA / HSPA+) are less than $\frac{1}{4}$ dB higher than the primary modes; therefore, SAR measurement is not required for HSDPA / HSUPA / DC-HSDPA / HSPA+.

HSDPA Setup Configuration:

Sub-test	β_c	β_d	β_d (SF)	β_c/β_d	$\beta_{hs}^{(j)}$	CM (dB) ⁽²⁾
1	2/15	15/15	64	2/15	4/15	0.0
2	12/15 ⁽³⁾	15/15 ⁽³⁾	64	12/15 ⁽³⁾	24/15	1.0
3	15/15	8/15	64	15/8	30/15	1.5
4	15/15	4/15	64	15/4	30/15	1.5

Note 1: $\Delta_{ACK}, \Delta_{NACK}$ and $\Delta_{CQI} = 8 \Leftrightarrow A_{hs} = \beta_{hs}/\beta_c = 30/15 \Leftrightarrow \beta_{hs} = 30/15 * \beta_c$
 Note 2: CM = 1 for $\beta_c/\beta_d = 12/15, \beta_{hs}/\beta_c = 24/15$.
 Note 3: For subtest 2 the β_c/β_d ratio of 12/15 for the TFC during the measurement period (TF1, TF0) is achieved by setting the signaled gain factors for the reference TFC (TF1, TF1) to $\beta_c = 11/15$ and $\beta_d = 15/15$.

HSUPA Setup Configuration:

Sub-test	β_c	β_d	β_d (SF)	β_c/β_d	$\beta_{hs}^{(1)}$	β_{ec}	β_{ed}	β_{ed} (SF)	β_{ed} (codes)	CM ⁽²⁾ (dB)	MPR (dB)	AG ⁽⁴⁾ Index	E-TFCI
1	11/15 ⁽³⁾	15/15 ⁽³⁾	64	11/15 ⁽³⁾	22/15	209/225	1039/225	4	1	1.0	0.0	20	75
2	6/15	15/15	64	6/15	12/15	12/15	94/75	4	1	3.0	2.0	12	67
3	15/15	9/15	64	15/9	30/15	30/15	β_{ed1} : 47/15 β_{ed2} : 47/15	4	2	2.0	1.0	15	92
4	2/15	15/15	64	2/15	4/15	2/15	56/75	4	1	3.0	2.0	17	71
5	15/15 ⁽⁴⁾	15/15 ⁽⁴⁾	64	15/15 ⁽⁴⁾	30/15	24/15	134/15	4	1	1.0	0.0	21	81

Note 1: Δ_{ACK} , Δ_{NACK} and $\Delta_{CQI} = 8 \Leftrightarrow A_{hs} = \beta_{hs}/\beta_c = 30/15 \Leftrightarrow \beta_{hs} = 30/15 * \beta_c$.

Note 2: CM = 1 for $\beta_c/\beta_d = 12/15$, $\beta_{hs}/\beta_c = 24/15$. For all other combinations of DPDCH, DPCCH, HS-DPCCH, E-DPDCH and E-DPCCH the MPR is based on the relative CM difference.

Note 3: For subtest 1 the β_c/β_d ratio of 11/15 for the TFC during the measurement period (TF1, TF0) is achieved by setting the signaled gain factors for the reference TFC (TF1, TF1) to $\beta_c = 10/15$ and $\beta_d = 15/15$.

Note 4: For subtest 5 the β_c/β_d ratio of 15/15 for the TFC during the measurement period (TF1, TF0) is achieved by setting the signaled gain factors for the reference TFC (TF1, TF1) to $\beta_c = 14/15$ and $\beta_d = 15/15$.

Note 5: Testing UE using E-DPDCH Physical Layer category 1 Sub-test 3 is not required according to TS 25.306 Table 5.1g.

Note 6: β_{ed} cannot be set directly; it is set by Absolute Grant Value.

HSPA+ 3GPP release 7 (uplink category 7) 16QAM, Setup Configuration:
Table C.11.1.4: β values for transmitter characteristics tests with HS-DPCCH and E-DCH with 16QAM

Sub-test	β_c (Note 3)	β_d	β_{hs} (Note 1)	β_{ec}	β_{ed} (2xSF2) (Note 4)	β_{ed} (2xSF4) (Note 4)	CM (dB) (Note 2)	MPR (dB) (Note 2)	AG Index (Note 4)	E-TFCI (Note 5)	E-TFCI (boost)
1	1	0	30/15	30/15	β_{ed1} : 30/15 β_{ed2} : 30/15	β_{ed3} : 24/15 β_{ed4} : 24/15	3.5	2.5	14	105	105

Note 1: Δ_{ACK} , Δ_{NACK} and $\Delta_{CQI} = 30/15$ with $\beta_{hs} = 30/15 * \beta_c$.

Note 2: CM = 3.5 and the MPR is based on the relative CM difference, MPR = MAX(CM-1,0).

Note 3: DPDCH is not configured, therefore the β_c is set to 1 and $\beta_d = 0$ by default.

Note 4: β_{ed} can not be set directly; it is set by Absolute Grant Value.

Note 5: All the sub-tests require the UE to transmit 2SF2+2SF4 16QAM EDCH and they apply for UE using E-DPDCH category 7. E-DCH TTI is set to 2ms TTI and E-DCH table index = 2. To support these E-DCH configurations DPDCH is not allocated. The UE is signaled to use the extrapolation algorithm.



Band		WCDMA II			Tune-up Limit (dBm)
TX Channel		9262	9400	9538	
Rx Channel		9662	9800	9938	
Frequency (MHz)		1852.4	1880	1907.6	
3GPP Rel 99	RMC 12.2Kbps	19.84	19.88	19.81	21.00
3GPP Rel 6	HSDPA Subtest-1	18.72	18.73	18.66	19.00
3GPP Rel 6	HSDPA Subtest-2	18.68	18.81	18.79	19.00
3GPP Rel 6	HSDPA Subtest-3	18.62	18.74	18.58	19.00
3GPP Rel 6	HSDPA Subtest-4	18.67	18.78	18.64	19.00
3GPP Rel 6	HSUPA Subtest-1	18.30	18.30	18.24	19.00
3GPP Rel 6	HSUPA Subtest-2	18.22	18.35	18.24	19.00
3GPP Rel 6	HSUPA Subtest-3	18.31	18.32	18.71	19.00
3GPP Rel 6	HSUPA Subtest-4	18.78	18.77	18.71	19.00
3GPP Rel 6	HSUPA Subtest-5	18.77	18.87	18.73	19.00
3GPP Rel 7	HSPA+ (16QAM) Subtest-1	18.52	18.57	18.59	19.00

Band		WCDMA V			Tune-up Limit (dBm)
TX Channel		4132	4183	4233	
Rx Channel		4357	4408	4458	
Frequency (MHz)		826.4	836.6	846.6	
3GPP Rel 99	RMC 12.2Kbps	22.65	22.90	22.63	23.50
3GPP Rel 6	HSDPA Subtest-1	21.66	21.83	21.63	22.00
3GPP Rel 6	HSDPA Subtest-2	21.71	21.85	21.74	22.00
3GPP Rel 6	HSDPA Subtest-3	21.81	21.85	21.71	22.00
3GPP Rel 6	HSDPA Subtest-4	21.64	21.70	21.60	22.00
3GPP Rel 6	HSUPA Subtest-1	21.20	21.41	21.31	22.00
3GPP Rel 6	HSUPA Subtest-2	21.20	21.18	21.15	22.00
3GPP Rel 6	HSUPA Subtest-3	21.30	21.49	21.21	22.00
3GPP Rel 6	HSUPA Subtest-4	21.76	21.98	21.72	22.00
3GPP Rel 6	HSUPA Subtest-5	21.74	21.98	21.70	22.00
3GPP Rel 7	HSPA+ (16QAM) Subtest-1	21.46	21.43	21.40	22.00

➤ **LTE Conducted Power**

Largest channel bandwidth standalone SAR test requirements

QPSK with 1 RB allocation

Start with the largest channel bandwidth and measure SAR for QPSK with 1 RB allocation, using the RB offset and required test channel combination with the highest maximum output power among RB offsets at the upper edge, middle and lower edge of each required test channel. When the reported SAR is ≤ 0.8 W/kg, testing of the remaining RB offset configurations and required test channels is not required for 1 RB allocation; otherwise, SAR is required for the remaining required test channels and only for the RB offset configuration with the highest output power for that channel.8 When the reported SAR of a required test channel is > 1.45 W/kg, SAR is required for all three RB offset configurations for that required test channel.

**QPSK with 50% RB allocation**

The procedures required for 1 RB allocation in section 4.2.1 are applied to measure the SAR for QPSK with 50% RB allocation.9

QPSK with 100% RB allocation

For QPSK with 100% RB allocation, SAR is not required when the highest maximum output power for 100 % RB allocation is less than the highest maximum output power in 50% and 1 RB allocations and the highest reported SAR for 1 RB and 50% RB allocation in sections 4.2.1 and 4.2.2 are ≤ 0.8 W/kg. Otherwise, SAR is measured for the highest output power channel; and if the reported SAR is > 1.45 W/kg, the remaining required test channels must also be tested.

Higher order modulations

For each modulation besides QPSK; e.g., 16-QAM, 64-QAM, apply the QPSK procedures in sections 4.2.1, 5.2.2 and 4.2.3 to determine the QAM configurations that may need SAR measurement. For each configuration identified as required for testing, SAR is required only when the highest maximum output power for the configuration in the higher order modulation is $> \frac{1}{2}$ dB higher than the same configuration in QPSK or when the reported SAR for the QPSK configuration is > 1.45 W/kg.

Other channel bandwidth standalone SAR test requirements

For the other channel bandwidths used by the device in a frequency band, apply all the procedures required for the largest channel bandwidth in section 4.2 to determine the channels and RB configurations that need SAR testing and only measure SAR when the highest maximum output power of a configuration requiring testing in the smaller channel bandwidth is $> \frac{1}{2}$ dB higher than the equivalent channel configurations in the largest channel bandwidth configuration or the reported SAR of a configuration for the largest channel bandwidth is > 1.45 W/kg. The equivalent channel configuration for the RB allocation, RB offset and modulation etc. is determined for the smaller channel bandwidth according to the same number of RB allocated in the largest channel bandwidth. For example, 50 RB in 10 MHz channel bandwidth does not apply to 5 MHz channel bandwidth; therefore, this cannot be tested in the smaller channel bandwidth. However, 50% RB allocation in 10 MHz channel bandwidth is equivalent to 100% RB allocation in 5 MHz channel bandwidth; therefore, these are the equivalent configurations to be compared to determine the specific channel and configuration in the smaller channel bandwidth that need SAR testing.

TDD LTE configuration setup for SAR measurement

SAR was tested with a fixed periodic duty factor according to the highest transmission duty factor implemented for the device and supported by 3GPP.

- a) 3GPP TS 36.211 section 4.2 for Type 2 Frame Structure and Table 4.2-2 for uplink-downlink configurations
- b) "special subframe S" contains both uplink and downlink transmissions. It has been taken into consideration to determine the transmission duty factor according to the worst case uplink and downlink cyclic prefix requirements for UpPTS

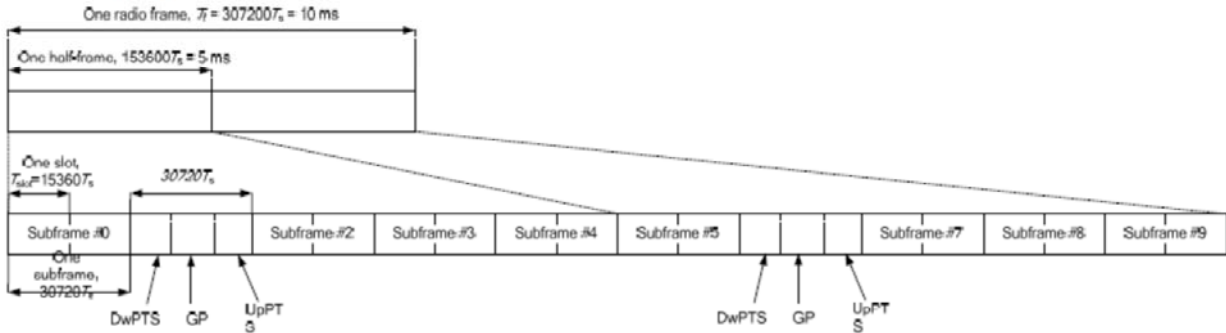

Uplink-downlink configuration	Downlink-to-Uplink Switch-point periodicity	Subframe number									
		0	1	2	3	4	5	6	7	8	9
0	5 ms	D	S	U	U	U	D	S	U	U	U
1	5 ms	D	S	U	U	D	D	S	U	U	D
2	5 ms	D	S	U	D	D	D	S	U	D	D
3	10 ms	D	S	U	U	U	D	D	D	D	D
4	10 ms	D	S	U	U	D	D	D	D	D	D
5	10 ms	D	S	U	D	D	D	D	D	D	D
6	5 ms	D	S	U	U	U	D	S	U	U	D

Special subframe configuration	Normal cyclic prefix in downlink			Extended cyclic prefix in downlink		
	DwPTS	UpPTS		DwPTS	UpPTS	
		Normal cyclic prefix in uplink	Extended cyclic prefix in uplink		Normal cyclic prefix in uplink	Extended cyclic prefix in uplink
0	$6592 \cdot T_s$	$2192 \cdot T_s$	$2560 \cdot T_s$	$7680 \cdot T_s$	$2192 \cdot T_s$	$2560 \cdot T_s$
1	$19760 \cdot T_s$			$20480 \cdot T_s$		
2	$21952 \cdot T_s$			$23040 \cdot T_s$		
3	$24144 \cdot T_s$			$25600 \cdot T_s$		
4	$26336 \cdot T_s$	$4384 \cdot T_s$	$5120 \cdot T_s$	$7680 \cdot T_s$	$4384 \cdot T_s$	$5120 \cdot T_s$
5	$6592 \cdot T_s$			$20480 \cdot T_s$		
6	$19760 \cdot T_s$			$23040 \cdot T_s$		
7	$21952 \cdot T_s$			$12800 \cdot T_s$		
8	$24144 \cdot T_s$			-		
9	$13168 \cdot T_s$	-	-	-	-	-



<FDD LTE Band 5>

BW [MHz]	Modulation	RB Size	RB Offset	Power Low Ch. / Freq.	Power Middle Ch. / Freq.	Power High Ch. / Freq.	Tune-up limit (dBm)
Channel				20450	20525	20600	
Frequency (MHz)				829	836.5	844	
10	QPSK	1	0	22.07	22.32	22.02	23.00
10	QPSK	1	25	21.96	22.19	22.31	
10	QPSK	1	49	21.82	21.88	21.88	
10	QPSK	25	0	21.02	21.11	21.12	22.00
10	QPSK	25	12	20.99	21.17	21.16	
10	QPSK	25	25	21.03	21.03	21.03	
10	QPSK	50	0	21.01	21.14	21.05	22.00
10	16QAM	1	0	21.36	21.54	21.16	
10	16QAM	1	25	21.14	21.18	21.19	
10	16QAM	1	49	21.20	20.77	20.83	21.00
10	16QAM	25	0	20.00	20.01	20.14	
10	16QAM	25	12	19.94	20.22	20.21	
10	16QAM	25	25	20.01	20.06	20.09	21.00
10	16QAM	50	0	19.99	20.06	19.96	
10	64QAM	1	0	20.74	20.90	20.98	
10	64QAM	1	25	20.96	20.91	20.93	21.00
10	64QAM	1	49	20.93	20.93	20.96	
10	64QAM	25	0	19.89	19.95	19.91	
10	64QAM	25	12	19.91	19.95	19.94	20.00
10	64QAM	25	25	19.96	19.96	19.99	
10	64QAM	50	0	19.94	19.93	19.96	
Channel				20425	20525	20625	Tune-up limit (dBm)
Frequency (MHz)				826.5	836.5	846.5	
5	QPSK	1	0	21.77	22.09	22.07	23.00
5	QPSK	1	12	21.74	22.00	21.95	
5	QPSK	1	24	21.72	21.66	21.82	
5	QPSK	12	0	20.72	20.84	20.88	22.00
5	QPSK	12	7	20.75	20.76	20.78	
5	QPSK	12	13	20.76	20.81	20.83	
5	QPSK	25	0	20.74	20.75	20.89	22.00
5	16QAM	1	0	21.22	20.87	21.39	
5	16QAM	1	12	21.34	20.86	21.25	
5	16QAM	1	24	21.17	21.30	21.35	21.00
5	16QAM	12	0	19.80	19.79	19.90	
5	16QAM	12	7	19.73	19.72	19.92	
5	16QAM	12	13	19.75	19.78	19.81	21.00
5	16QAM	25	0	19.84	19.74	19.96	
5	64QAM	1	0	20.95	20.94	20.73	21.00



5	64QAM	1	12	20.97	20.89	20.94	20.00
5	64QAM	1	24	20.69	20.87	20.68	
5	64QAM	12	0	19.75	19.80	19.79	
5	64QAM	12	7	19.79	19.73	19.87	
5	64QAM	12	13	19.71	19.80	19.71	
5	64QAM	25	0	19.83	19.83	19.89	
Channel				20415	20525	20635	Tune-up limit (dBm)
Frequency (MHz)				825.5	836.5	847.5	
3	QPSK	1	0	21.91	22.04	22.02	23.00
3	QPSK	1	8	21.83	22.06	22.08	
3	QPSK	1	14	21.77	21.69	21.84	
3	QPSK	8	0	20.85	20.79	20.85	22.00
3	QPSK	8	4	20.80	20.80	20.92	
3	QPSK	8	7	20.87	20.76	20.87	
3	QPSK	15	0	20.87	20.78	20.88	
3	16QAM	1	0	21.25	20.94	21.30	22.00
3	16QAM	1	8	21.32	21.39	21.08	
3	16QAM	1	14	21.20	21.04	21.01	
3	16QAM	8	0	19.89	19.88	19.99	21.00
3	16QAM	8	4	19.97	19.95	19.91	
3	16QAM	8	7	19.92	19.75	19.91	
3	16QAM	15	0	19.82	19.87	19.80	
3	64QAM	1	0	20.88	20.94	20.97	21.00
3	64QAM	1	8	20.98	20.93	20.93	
3	64QAM	1	14	20.91	20.94	20.96	
3	64QAM	8	0	19.78	19.81	19.94	20.00
3	64QAM	8	4	19.91	19.82	19.92	
3	64QAM	8	7	19.80	19.79	19.93	
3	64QAM	15	0	19.81	19.79	19.86	
Channel				20407	20525	20643	Tune-up limit (dBm)
Frequency (MHz)				824.7	836.5	848.3	
1.4	QPSK	1	0	21.85	22.06	22.04	23.00
1.4	QPSK	1	3	21.97	22.10	22.06	
1.4	QPSK	1	5	21.78	21.73	21.82	
1.4	QPSK	3	0	21.85	21.74	21.95	
1.4	QPSK	3	1	21.84	21.86	21.99	
1.4	QPSK	3	3	21.80	21.85	21.95	
1.4	QPSK	6	0	20.80	20.70	20.94	22.00
1.4	16QAM	1	0	21.15	21.05	20.94	22.00
1.4	16QAM	1	3	21.27	21.23	21.08	
1.4	16QAM	1	5	20.83	21.12	20.94	
1.4	16QAM	3	0	20.83	20.84	20.87	
1.4	16QAM	3	1	20.78	20.95	20.93	
1.4	16QAM	3	3	20.89	20.75	21.00	



1.4	16QAM	6	0	19.94	19.83	19.98	21.00
1.4	64QAM	1	0	20.94	20.86	20.95	21.00
1.4	64QAM	1	3	20.97	20.94	20.98	
1.4	64QAM	1	5	20.96	20.85	20.98	
1.4	64QAM	3	0	21.00	20.85	20.88	
1.4	64QAM	3	1	20.97	20.91	20.93	
1.4	64QAM	3	3	20.90	20.64	20.77	
1.4	64QAM	6	0	19.75	19.81	19.76	20.00

<FDD LTE Band 7>

BW [MHz]	Modulation	RB Size	RB Offset	Power Middle Ch. / Freq.	Power High Ch. / Freq.	Power Middle Ch. / Freq.	Tune-up limit (dBm)
Channel				20850	21100	21350	
Frequency (MHz)				2510	2535	2560	
20	QPSK	1	0	22.37	22.48	22.38	23.00
20	QPSK	1	49	22.31	22.14	22.42	
20	QPSK	1	99	22.37	22.36	22.40	
20	QPSK	50	0	21.37	21.45	21.09	22.00
20	QPSK	50	24	21.35	21.08	21.01	
20	QPSK	50	50	21.38	21.19	21.12	
20	QPSK	100	0	21.38	21.09	21.00	22.00
20	16QAM	1	0	21.34	21.30	21.64	
20	16QAM	1	49	21.72	21.61	21.51	
20	16QAM	1	99	21.55	21.70	21.62	21.00
20	16QAM	50	0	20.35	20.10	20.10	
20	16QAM	50	24	20.46	20.09	20.00	
20	16QAM	50	50	20.41	20.18	20.02	21.50
20	16QAM	100	0	20.44	20.16	20.03	
20	64QAM	1	0	21.35	21.43	21.42	
20	64QAM	1	49	21.40	21.13	21.02	20.50
20	64QAM	1	99	21.47	21.17	21.41	
20	64QAM	50	0	20.38	20.07	19.93	
20	64QAM	50	24	20.48	20.08	20.10	22.00
20	64QAM	50	50	20.41	20.20	20.00	
20	64QAM	100	0	20.39	20.15	19.96	
Channel				20825	21100	21375	Tune-up limit (dBm)
Frequency (MHz)				2507.5	2535	2562.5	
15	QPSK	1	0	22.08	21.90	21.93	23.00
15	QPSK	1	37	22.45	22.02	22.02	
15	QPSK	1	74	22.33	22.15	21.98	
15	QPSK	36	0	21.30	20.95	20.79	22.00
15	QPSK	36	20	21.34	21.14	20.88	
15	QPSK	36	39	21.35	21.10	20.93	



15	QPSK	75	0	21.37	21.08	20.85	
15	16QAM	1	0	21.38	20.97	21.25	22.00
15	16QAM	1	37	21.62	21.05	21.09	
15	16QAM	1	74	21.47	21.56	21.38	
15	16QAM	36	0	20.34	19.94	19.80	21.00
15	16QAM	36	20	20.43	20.14	20.02	
15	16QAM	36	39	20.26	20.10	19.77	
15	16QAM	75	0	20.34	20.07	19.98	21.50
15	64QAM	1	0	21.19	20.69	20.70	
15	64QAM	1	37	21.15	21.15	21.23	
15	64QAM	1	74	20.54	20.64	20.76	20.50
15	64QAM	36	0	20.45	20.11	19.83	
15	64QAM	36	20	20.38	20.09	19.82	
15	64QAM	36	39	20.33	20.11	19.92	Tune-up limit (dBm)
15	64QAM	75	0	20.12	20.15	20.22	
Channel				20800	21100	21400	
Frequency (MHz)				2505	2535	2565	
10	QPSK	1	0	22.29	22.27	22.33	23.00
10	QPSK	1	25	22.44	22.14	21.99	
10	QPSK	1	49	22.42	22.35	22.21	
10	QPSK	25	0	21.55	21.58	21.53	22.00
10	QPSK	25	12	21.59	21.53	21.99	
10	QPSK	25	25	21.63	21.59	21.51	
10	QPSK	50	0	21.62	21.19	21.53	22.00
10	16QAM	1	0	21.61	21.52	21.49	
10	16QAM	1	25	21.35	21.37	21.28	
10	16QAM	1	49	21.89	21.90	21.74	21.00
10	16QAM	25	0	20.51	20.14	20.22	
10	16QAM	25	12	20.51	20.11	20.03	
10	16QAM	25	25	20.58	20.21	20.02	21.50
10	16QAM	50	0	20.54	20.21	20.13	
10	64QAM	1	0	21.28	21.24	21.36	
10	64QAM	1	25	21.35	21.45	21	21.00
10	64QAM	1	49	21.49	21.34	21.41	
10	64QAM	25	0	20.47	20.08	20.05	
10	64QAM	25	12	20.53	20.15	20.15	Tune-up limit (dBm)
10	64QAM	25	25	20.57	20.16	20.16	
10	64QAM	50	0	20.56	20.17	20.13	
Channel				20775	21100	21425	
Frequency (MHz)				2502.5	2535	2567.5	
5	QPSK	1	0	22.29	22.05	22.07	23.00
5	QPSK	1	12	22.16	21.95	22.06	
5	QPSK	1	24	22.38	22.08	21.99	
5	QPSK	12	0	21.46	21.02	21.05	22.00



5	QPSK	12	7	21.43	21.14	21.08	
5	QPSK	12	13	21.36	21.13	21.06	
5	QPSK	25	0	21.34	21.13	21.06	
5	16QAM	1	0	21.97	21.31	21.59	22.00
5	16QAM	1	12	21.86	21.22	21.52	
5	16QAM	1	24	21.93	21.23	21.61	
5	16QAM	12	0	20.44	20.06	20.04	21.00
5	16QAM	12	7	20.41	20.18	20.10	
5	16QAM	12	13	20.37	20.08	20.11	
5	16QAM	25	0	20.41	20.12	20.15	21.50
5	64QAM	1	0	21.15	21.33	21.27	
5	64QAM	1	12	21.25	21.27	21.01	
5	64QAM	1	24	21.30	21.24	21.24	20.50
5	64QAM	12	0	20.33	20.03	20.04	
5	64QAM	12	7	20.52	20.11	20.12	
5	64QAM	12	13	20.40	20.00	20.12	20.50
5	64QAM	25	0	20.42	20.10	20.16	

<TDD LTE Band 38>

BW [MHz]	Modulation	RB Size	RB Offset	Power Low Ch. / Freq.	Power Middle Ch. / Freq.	Power High Ch. / Freq.	Tune-up limit (dBm)
Channel				37850	38000	38150	
Frequency (MHz)				2580	2595	2610	
20	QPSK	1	0	23.39	23.79	23.32	24.00
20	QPSK	1	49	23.40	22.92	23.04	
20	QPSK	1	99	23.36	22.83	22.73	
20	QPSK	50	0	22.51	22.61	22.36	23.00
20	QPSK	50	24	22.48	22.12	22.24	
20	QPSK	50	50	22.46	22.11	22.10	
20	QPSK	100	0	22.56	22.13	22.30	23.00
20	16QAM	1	0	22.98	22.86	22.70	
20	16QAM	1	49	22.53	22.20	22.34	
20	16QAM	1	99	22.53	21.92	22.03	22.00
20	16QAM	50	0	21.65	21.28	21.36	
20	16QAM	50	24	21.51	21.19	21.24	
20	16QAM	50	50	21.31	21.07	21.11	22.00
20	16QAM	100	0	21.61	21.21	21.15	
20	64QAM	1	0	22.95	22.62	22.77	
20	64QAM	1	49	22.48	21.91	22.22	23.00
20	64QAM	1	99	22.45	21.97	22.01	
20	64QAM	50	0	21.67	21.19	21.23	22.00
20	64QAM	50	24	21.44	21.01	21.19	
20	64QAM	50	50	21.34	21.12	21.14	



20	64QAM	100	0	21.63	21.04	21.35	
Channel				37825	38000	38175	Tune-up limit (dBm)
Frequency (MHz)				2577.5	2595	2612.5	
15	QPSK	1	0	23.68	23.25	23.03	24.00
15	QPSK	1	37	23.52	23.01	22.88	
15	QPSK	1	74	23.18	22.76	23.03	
15	QPSK	36	0	22.50	22.10	21.98	23.00
15	QPSK	36	20	22.38	22.10	22.20	
15	QPSK	36	39	22.35	21.85	22.09	
15	QPSK	75	0	22.25	22.20	22.11	
15	16QAM	1	0	22.82	22.57	22.55	23.00
15	16QAM	1	37	22.69	22.43	22.37	
15	16QAM	1	74	22.47	22.20	22.02	
15	16QAM	36	0	21.52	21.05	21.57	22.00
15	16QAM	36	20	21.30	21.05	21.19	
15	16QAM	36	39	21.27	20.99	21.08	
15	16QAM	75	0	21.40	21.17	21.21	
15	64QAM	1	0	22.68	22.20	22.45	23.00
15	64QAM	1	37	22.35	22.18	22.10	
15	64QAM	1	74	21.52	21.15	21.16	
15	64QAM	36	0	21.31	21.06	21.19	22.00
15	64QAM	36	20	21.28	21.01	21.18	
15	64QAM	36	39	21.38	21.16	21.19	
15	64QAM	75	0	21.20	21.02	21.12	
Channel				37800	38000	38200	Tune-up limit (dBm)
Frequency (MHz)				2575	2595	2615	
10	QPSK	1	0	23.53	22.92	22.96	24.00
10	QPSK	1	25	23.04	22.75	22.61	
10	QPSK	1	49	23.28	23.00	22.75	
10	QPSK	25	0	22.56	21.97	22.05	23.00
10	QPSK	25	12	22.34	22.11	22.01	
10	QPSK	25	25	22.25	21.90	21.89	
10	QPSK	50	0	22.43	21.93	21.98	
10	16QAM	1	0	22.69	22.30	22.38	23.00
10	16QAM	1	25	22.44	22.25	22.09	
10	16QAM	1	49	22.49	22.10	21.88	
10	16QAM	25	0	21.39	21.17	21.18	22.00
10	16QAM	25	12	21.39	20.92	21.05	
10	16QAM	25	25	21.22	21.08	20.93	
10	16QAM	50	0	21.30	21.03	21.09	
10	64QAM	1	0	22.69	22.37	22.18	23.00
10	64QAM	1	25	22.41	22.09	22.00	
10	64QAM	1	49	21.99	21.94	21.97	
10	64QAM	25	0	21.54	21.10	21.12	22.00



10	64QAM	25	12	21.32	21.06	21.07	
10	64QAM	25	25	21.24	20.83	20.88	
10	64QAM	50	0	21.30	21.04	20.96	
Channel				37775	38000	38225	Tune-up limit (dBm)
Frequency (MHz)				2572.5	2595	2617.5	
5	QPSK	1	0	23.61	22.90	22.94	24.00
5	QPSK	1	12	23.17	23.14	22.83	
5	QPSK	1	24	23.41	22.92	22.79	
5	QPSK	12	0	22.40	22.23	22.12	23.00
5	QPSK	12	7	22.53	22.22	21.99	
5	QPSK	12	13	22.54	22.09	21.99	
5	QPSK	25	0	22.47	22.17	22.00	23.00
5	16QAM	1	0	22.76	22.33	22.11	
5	16QAM	1	12	22.77	22.43	22.05	
5	16QAM	1	24	22.65	22.24	22.22	22.00
5	16QAM	12	0	21.59	21.22	21.21	
5	16QAM	12	7	21.57	21.20	21.17	
5	16QAM	12	13	21.60	21.16	21.09	22.00
5	16QAM	25	0	21.55	21.19	21.05	
5	64QAM	1	0	22.73	22.10	22.22	
5	64QAM	1	12	22.55	22.18	22.14	
5	64QAM	1	24	22.53	22.19	22.05	
5	64QAM	12	0	21.55	21.16	21.09	22.00
5	64QAM	12	7	21.64	20.95	20.96	
5	64QAM	12	13	21.53	21.11	20.88	
5	64QAM	25	0	21.59	21.00	20.99	

<TDD LTE Band 40A>

BW [MHz]	Modulation	RB Size	RB Offset	Power Low Ch. / Freq.	Power Middle Ch. / Freq.	Power High Ch. / Freq.	Tune-up limit (dBm)
Channel				38750			
Frequency (MHz)				2310			
10	QPSK	1	0		22.91		23.50
10	QPSK	1	25		22.63		
10	QPSK	1	49		22.40		
10	QPSK	25	0		21.70		22.50
10	QPSK	25	12		21.69		
10	QPSK	25	25		21.60		
10	QPSK	50	0		21.81		22.50
10	16QAM	1	0		22.10		
10	16QAM	1	25		21.83		
10	16QAM	1	49		21.59		21.50
10	16QAM	25	0		20.81		
10	16QAM	25	12		20.77		
10	16QAM	25	25		20.57		



10	16QAM	50	0	20.78			22.50
10	64QAM	1	0	21.99			
10	64QAM	1	25	21.83			
10	64QAM	1	49	21.58			
10	64QAM	25	0	20.84			21.00
10	64QAM	25	12	20.78			
10	64QAM	25	25	20.39			
10	64QAM	50	0	20.71			
Channel				38725	38750	38775	Tune-up limit (dBm)
Frequency (MHz)				2307.5	2310	2312.5	
5	QPSK	1	0	22.88	22.77	22.78	23.50
5	QPSK	1	12	22.85	22.90	22.74	
5	QPSK	1	24	22.62	22.69	22.70	
5	QPSK	12	0	21.84	21.66	21.70	22.50
5	QPSK	12	7	21.85	21.83	21.71	
5	QPSK	12	13	21.84	21.64	21.67	
5	QPSK	25	0	21.80	21.79	21.68	
5	16QAM	1	0	22.19	22.07	21.99	22.50
5	16QAM	1	12	21.89	21.92	22.00	
5	16QAM	1	24	22.00	21.97	21.85	
5	16QAM	12	0	20.87	20.91	20.84	21.50
5	16QAM	12	7	20.94	21.02	20.96	
5	16QAM	12	13	20.80	20.70	20.60	
5	16QAM	25	0	20.90	20.86	20.52	
5	64QAM	1	0	21.77	22.05	22.08	22.50
5	64QAM	1	12	21.89	21.66	21.50	
5	64QAM	1	24	21.46	21.69	21.48	
5	64QAM	12	0	20.78	20.86	20.67	21.00
5	64QAM	12	7	20.85	20.83	20.80	
5	64QAM	12	13	20.83	20.53	20.66	
5	64QAM	25	0	20.82	20.60	20.67	

<TDD LTE Band 40B>

BW [MHz]	Modulation	RB Size	RB Offset	Power Low Ch. / Freq.	Power Middle Ch. / Freq.	Power High Ch. / Freq.	Tune-up limit (dBm)
Channel				39200			
Frequency (MHz)				2355			
10	QPSK	1	0	22.90			23.50
10	QPSK	1	25	22.91			
10	QPSK	1	49	22.77			
10	QPSK	25	0	21.90			22.50
10	QPSK	25	12	21.79			
10	QPSK	25	25	21.83			



10	QPSK	50	0	21.80			
10	16QAM	1	0	22.17			22.50
10	16QAM	1	25	22.00			
10	16QAM	1	49	21.91			
10	16QAM	25	0	20.83			21.50
10	16QAM	25	12	20.84			
10	16QAM	25	25	20.79			
10	16QAM	50	0	20.85			
10	64QAM	1	0	22.02			22.50
10	64QAM	1	25	21.76			
10	64QAM	1	49	21.51			
10	64QAM	25	0	20.65			21.00
10	64QAM	25	12	20.77			
10	64QAM	25	25	20.72			
10	64QAM	50	0	20.77			
Channel				39175	39200	39225	Tune-up limit (dBm)
Frequency (MHz)				2352.5	2355	2357.5	
5	QPSK	1	0	22.91	22.85	22.78	23.50
5	QPSK	1	12	22.83	22.81	22.75	
5	QPSK	1	24	22.83	22.63	22.74	
5	QPSK	12	0	21.85	21.75	21.87	22.50
5	QPSK	12	7	21.75	21.64	21.66	
5	QPSK	12	13	21.65	21.75	21.83	
5	QPSK	25	0	21.70	21.79	21.86	
5	16QAM	1	0	21.95	22.07	21.99	22.50
5	16QAM	1	12	22.03	21.96	22.09	
5	16QAM	1	24	21.87	21.90	21.92	
5	16QAM	12	0	20.87	20.77	20.92	21.50
5	16QAM	12	7	20.77	20.87	20.70	
5	16QAM	12	13	20.69	20.68	20.87	
5	16QAM	25	0	20.82	20.85	20.69	
5	64QAM	1	0	21.69	21.92	21.74	22.50
5	64QAM	1	12	21.89	21.88	21.62	
5	64QAM	1	24	21.82	21.75	21.85	
5	64QAM	12	0	20.80	20.71	20.85	21.00
5	64QAM	12	7	20.78	20.82	20.86	
5	64QAM	12	13	20.50	20.72	20.71	
5	64QAM	25	0	20.67	20.77	20.73	



<TDD LTE Band 41>

BW [MHz]	Modulation	RB Size	RB Offset	Power Low Ch. / Freq.	Power Middle Low Ch. / Freq.	Power Middle High Ch. / Freq.	Power High Ch. / Freq.	Tune-up limit (dBm)
Channel				40340	40600	40870	41140	
Frequency (MHz)				2565	2591	2618	2645	
20	QPSK	1	0	23.98	23.92	23.43	23.27	24.00
20	QPSK	1	49	23.49	23.50	22.76	22.86	
20	QPSK	1	99	23.58	23.48	22.87	22.70	
20	QPSK	50	0	22.83	22.58	22.36	22.28	23.00
20	QPSK	50	24	22.77	22.30	22.00	21.91	
20	QPSK	50	50	22.71	22.49	22.11	21.70	
20	QPSK	100	0	22.77	22.66	22.18	21.83	23.00
20	16QAM	1	0	22.95	22.89	22.67	22.41	
20	16QAM	1	49	22.70	22.66	22.10	22.09	
20	16QAM	1	99	22.78	22.60	22.02	21.95	22.00
20	16QAM	50	0	21.73	21.68	21.37	21.06	
20	16QAM	50	24	21.76	21.39	21.09	20.92	
20	16QAM	50	50	21.60	21.39	20.92	20.87	22.00
20	16QAM	100	0	21.75	21.48	20.99	21.03	
20	64QAM	1	0	22.79	22.73	22.55	22.50	
20	64QAM	1	49	22.67	22.41	22.07	22.08	23.00
20	64QAM	1	99	22.72	22.12	21.90	21.54	
20	64QAM	50	0	21.84	21.70	21.21	21.08	
20	64QAM	50	24	21.78	21.32	21.03	20.77	22.00
20	64QAM	50	50	21.52	21.32	20.94	20.79	
20	64QAM	100	0	21.78	21.72	21.23	20.86	
Channel				40315	40595	40885	41165	Tune-up limit (dBm)
Frequency (MHz)				2562.5	2590.5	2619.5	2647.5	
15	QPSK	1	0	22.79	23.59	23.57	23.01	24.00
15	QPSK	1	37	23.45	23.37	23.09	22.65	
15	QPSK	1	74	23.69	23.27	23.05	22.47	
15	QPSK	36	0	22.89	22.60	22.33	21.90	23.00
15	QPSK	36	20	22.74	22.61	22.12	21.97	
15	QPSK	36	39	22.64	22.49	22.07	21.70	
15	QPSK	75	0	22.84	22.30	22.23	21.94	23.00
15	16QAM	1	0	22.91	22.98	22.67	22.37	
15	16QAM	1	37	22.88	22.84	22.26	22.16	
15	16QAM	1	74	22.95	22.54	22.02	21.94	22.00
15	16QAM	36	0	21.86	21.59	21.29	20.85	
15	16QAM	36	20	21.60	21.46	21.08	21.03	
15	16QAM	36	39	21.61	21.37	21.06	20.65	22.00
15	16QAM	75	0	21.64	21.29	21.15	20.94	



15	64QAM	1	0	22.89	22.87	22.56	22.38	23.00
15	64QAM	1	37	22.56	22.19	22.07	21.94	
15	64QAM	1	74	21.87	21.71	21.23	21.18	
15	64QAM	36	0	21.71	21.59	21.10	20.98	22.00
15	64QAM	36	20	21.62	21.39	21.07	20.87	
15	64QAM	36	39	21.84	21.57	21.05	20.92	
15	64QAM	75	0	21.56	21.36	21.40	21.50	
Channel				40290	40590	40890	41190	Tune-up limit (dBm)
Frequency (MHz)				2560	2590	2620	2650	
10	QPSK	1	0	23.73	23.60	22.84	22.72	24.00
10	QPSK	1	25	23.68	23.41	22.85	22.85	
10	QPSK	1	49	23.70	23.33	22.70	22.61	
10	QPSK	25	0	22.76	22.53	21.99	21.97	23.00
10	QPSK	25	12	22.76	22.56	21.95	21.83	
10	QPSK	25	25	22.72	22.29	21.96	21.64	
10	QPSK	50	0	22.70	22.50	22.00	21.72	
10	16QAM	1	0	22.95	22.69	22.15	22.27	23.00
10	16QAM	1	25	22.92	22.54	22.02	22.05	
10	16QAM	1	49	22.87	22.54	22.01	21.92	
10	16QAM	25	0	21.77	21.57	21.09	20.68	22.00
10	16QAM	25	12	21.77	21.58	21.07	20.97	
10	16QAM	25	25	21.69	21.28	20.96	20.84	
10	16QAM	50	0	21.68	21.52	21.03	20.85	
10	64QAM	1	0	22.64	22.55	22.05	22.16	22.00
10	64QAM	1	25	22.59	22.49	21.91	22.06	
10	64QAM	1	49	22.74	22.08	21.91	21.59	
10	64QAM	25	0	21.72	21.29	21.12	20.94	21.00
10	64QAM	25	12	21.81	21.51	20.91	20.90	
10	64QAM	25	25	21.72	21.44	20.90	20.58	
10	64QAM	50	0	21.70	21.34	20.97	20.77	
Channel				40265	40585	40905	41215	Tune-up limit (dBm)
Frequency (MHz)				2557.5	2589.5	2621.5	2652.5	
5	QPSK	1	0	23.65	23.52	22.94	22.91	24.00
5	QPSK	1	12	23.66	23.13	22.82	22.74	
5	QPSK	1	24	23.55	23.38	22.84	22.52	
5	QPSK	12	0	22.74	22.32	21.94	21.55	23.00
5	QPSK	12	7	22.68	22.46	21.84	21.72	
5	QPSK	12	13	22.67	22.39	21.92	21.47	
5	QPSK	25	0	22.67	22.26	21.94	21.78	
5	16QAM	1	0	22.85	22.43	22.23	21.96	23.00
5	16QAM	1	12	22.85	22.68	21.95	21.86	
5	16QAM	1	24	22.78	22.53	21.87	21.91	
5	16QAM	12	0	21.75	21.54	20.97	20.65	22.00
5	16QAM	12	7	21.77	21.56	20.94	20.86	
5	16QAM	12	13	21.74	21.31	20.91	20.65	



5	16QAM	25	0	21.76	21.46	20.95	20.54	
5	64QAM	1	0	22.83	22.63	21.96	21.99	23.00
5	64QAM	1	12	22.74	22.34	22.04	21.83	
5	64QAM	1	24	22.65	22.41	21.87	21.68	
5	64QAM	12	0	21.69	21.46	21.01	20.51	22.00
5	64QAM	12	7	21.73	21.51	20.82	20.82	
5	64QAM	12	13	21.59	21.15	20.87	20.59	
5	64QAM	25	0	21.61	21.22	20.90	20.66	



➤ **WLAN Conducted Power**
<2.4GHz WLAN ANT 0>

	Mode	Channel	Frequency (MHz)	Average power (dBm)	Tune-Up Limit	Power Setting	Duty Cycle %
2.4GHz WLAN ANT 0	802.11b 1Mbps	CH 1	2412	15.58	16.00	16.00	99.04
		CH 6	2437	15.51	16.00	16.00	
		CH 11	2462	15.59	16.00	16.00	
	802.11g 6Mbps	CH 1	2412	15.07	15.50	16.00	94.95
		CH 6	2437	14.93	15.50	16.00	
		CH 11	2462	15.04	15.50	16.00	
	802.11n- HT20 MCS0	CH 1	2412	12.94	12.50	14.00	95.07
		CH 6	2437	12.90	12.50	14.00	
		CH 11	2462	12.94	12.50	14.00	
	802.11n- HT40 MCS0	CH 3	2422	13.08	14.50	14.00	90.05
		CH 6	2437	13.07	14.50	14.00	
		CH 9	2452	13.39	13.50	14.00	

<2.4GHz WLAN ANT 1>

	Mode	Channel	Frequency (MHz)	Average power (dBm)	Tune-Up Limit	Power Setting	Duty Cycle %
2.4GHz WLAN ANT 1	802.11b 1Mbps	CH 1	2412	15.18	16.00	16.00	99.04
		CH 6	2437	15.05	16.00	16.00	
		CH 11	2462	15.28	16.00	16.00	
	802.11g 6Mbps	CH 1	2412	14.58	15.00	16.00	94.95
		CH 6	2437	14.47	15.00	16.00	
		CH 11	2462	14.73	15.00	16.00	
	802.11n- HT20 MCS0	CH 1	2412	12.52	13.00	14.00	95.07
		CH 6	2437	12.38	13.00	14.00	
		CH 11	2462	12.61	13.00	14.00	
	802.11n- HT40 MCS0	CH 3	2422	12.66	13.00	14.00	90.05
		CH 6	2437	12.55	13.00	14.00	
		CH 9	2452	12.50	13.00	14.00	



Note:

- Per KDB 447498 D01v06, the 1-g SAR test exclusion thresholds for 100 MHz to 6 GHz at *test separation distances* ≤ 50 mm are determined by:

$[(\text{max. power of channel, including tune-up tolerance, mW}) / (\text{min. test separation distance, mm})] \cdot [\sqrt{f(\text{GHz})}] \leq 3.0$ for 1-g SAR, where

- f(GHz) is the RF channel transmit frequency in GHz
- Power and distance are rounded to the nearest mW and mm before calculation
- The result is rounded to one decimal place for comparison

Antenna	Frequency (GHz)	Max. Tune-up Power (dBm)	Max. Power (mW)	Test distance (mm)	Result	exclusion thresholds for 1-g SAR
ANT 0	2.462	16.00	39.81	10	6.25	3.0
ANT 1	2.462	16.00	39.81	10	6.25	3.0

- Base on the result of note1, RF exposure evaluation of 802.11 b and g mode is required.
- Per KDB 248227 D01v02r02, choose the highest output power channel to test SAR and determine further SAR exclusion.
- Per KDB 248227 D01v02r02, In the 2.4 GHz band, separate SAR procedures are applied to DSSS and OFDM configurations to simplify DSSS test requirements. SAR is not required for the following 2.4 GHz OFDM conditions:
 - When KDB Publication 447498 SAR test exclusion applies to the OFDM configuration.
 - When the highest reported SAR for DSSS is adjusted by the ratio of OFDM to DSSS specified maximum output power and the adjusted SAR is ≤ 1.2 W/kg.
- The output power of all data rate were pre-scan, just the worst case (the lowest data rate) of all mode were shown in report.

<5.2GHz WLAN ANT 0>

5.2GHz WLAN ANT 0	Mode	Channel	Frequency (MHz)	Average power (dBm)	Tune-Up Limit	Power Setting	Duty Cycle %
	802.11a 6Mbps	CH 36	5180	11.48	12.00	13.00	94.93
CH 44		5220	11.39	12.00	13.00		
CH 48		5240	11.58	12.00	13.00		
802.11n-HT20 MCS0	CH 36	5180	12.29	13.00	13.00	94.58	
	CH 44	5220	12.15	13.00	13.00		
	CH 48	5240	12.28	13.00	13.00		
802.11n-HT40 MCS0	CH 38	5190	12.42	13.00	13.00	90.05	
	CH 46	5230	12.49	13.00	13.00		
802.11ac-VHT20	CH 36	5180	11.07	12.00	13.00	95.07	
	CH 44	5220	11.03	12.00	13.00		



	MCS0	CH 48	5240	11.16	12.00	13.00	90.05
	802.11ac-VHT40 MCS0	CH 38	5190	11.45	12.00	13.00	
		CH 46	5230	11.60	12.00	13.00	

<5.2GHz WLAN ANT 1>

5.2GHz WLAN ANT 1	Mode	Channel	Frequency (MHz)	Average power (dBm)	Tune-Up Limit	Power Setting	Duty Cycle %
	802.11a 6Mbps		CH 36	5180	10.99	11.50	13.00
CH 44			5220	10.93	11.50	13.00	
CH 48			5240	11.10	11.50	13.00	
802.11n-HT20 MCS0		CH 36	5180	12.08	12.50	13.00	94.58
		CH 44	5220	11.83	12.50	13.00	
		CH 48	5240	11.86	12.50	13.00	
802.11n-HT40 MCS0		CH 38	5190	12.25	12.50	13.00	90.05
		CH 46	5230	12.26	12.50	13.00	
802.11ac-VHT20 MCS0		CH 36	5180	10.96	12.50	13.00	95.07
		CH 44	5220	10.81	11.50	13.00	
		CH 48	5240	10.93	11.50	13.00	
802.11ac-VHT40 MCS0		CH 38	5190	11.19	11.50	13.00	90.05
		CH 46	5230	11.25	11.50	13.00	

Note:

- Per KDB 447498 D01v06, the 1-g SAR test exclusion thresholds for 100 MHz to 6 GHz at *test separation distances* ≤50 mm are determined by:

$$[(\text{max. power of channel, including tune-up tolerance, mW}) / (\text{min. test separation distance, mm})] \cdot [\sqrt{f(\text{GHz})}] \leq 3.0 \text{ for 1-g SAR, where}$$

- f(GHz) is the RF channel transmit frequency in GHz
- Power and distance are rounded to the nearest mW and mm before calculation
- The result is rounded to one decimal place for comparison

Antenna	Frequency (GHz)	Max. Tune-up Power (dBm)	Max. Power (mW)	Test distance (mm)	Result	exclusion thresholds for 1-g SAR
ANT 0	5.23	13.00	19.95	10	4.56	3.0
ANT 1	5.23	12.50	17.78	10	4.07	3.0

- Per KDB 248227 D01v02r02, choose the highest output power channel to test SAR and determine further SAR exclusion.
- The output power of all data rate were pre-scan, just the worst case (the lowest data rate) of all mode were shown in report.
- Per KDB 248227 D01V02r02 section 2.2, when the EUT in continuously transmitting mode, the actual duty cycle is 100%, so the duty cycle factor is 1.



<5.8GHz WLAN ANT 0>

	Mode	Channel	Frequency (MHz)	Average power (dBm)	Tune-Up Limit	Power Setting	Duty Cycle %
5.8GHz WLAN ANT 0	802.11a MCS0	CH 149	5745	10.97	11.50	13.00	94.93
		CH 157	5785	10.89	11.50	13.00	
		CH 165	5825	10.95	11.50	13.00	
	802.11n-HT20 MCS0	CH 149	5745	11.64	12.00	13.00	94.58
		CH 157	5785	11.53	12.00	13.00	
		CH 165	5825	11.57	12.00	13.00	
	802.11n-HT40 MCS0	CH 151	5755	11.94	12.50	13.00	90.05
		CH 159	5795	11.87	12.50	13.00	
	802.11ac-VHT20 MCS0	CH 149	5745	10.61	11.00	13.00	95.07
		CH 157	5785	10.56	11.00	13.00	
		CH 165	5825	10.56	11.00	13.00	
	802.11ac-VHT40 MCS0	CH 151	5755	10.99	11.50	13.00	90.05
CH 159		5795	11.01	11.50	13.00		

<5.8GHz WLAN ANT 1>

	Mode	Channel	Frequency (MHz)	Average power (dBm)	Tune-Up Limit	Power Setting	Duty Cycle %
5.8GHz WLAN ANT 1	802.11a MCS0	CH 149	5745	15.14	15.50	13.00	94.93
		CH 157	5785	15.02	15.50	13.00	
		CH 165	5825	9.88	10.50	13.00	
	802.11n-HT20 MCS0	CH 149	5745	15.97	16.50	13.00	94.58
		CH 157	5785	15.83	16.50	13.00	
		CH 165	5825	10.63	11.00	13.00	
	802.11n-HT40 MCS0	CH 151	5755	16.28	16.50	13.00	90.05
		CH 159	5795	10.87	11.50	13.00	
	802.11ac-VHT20 MCS0	CH 149	5745	15.01	15.50	13.00	95.07
		CH 157	5785	14.82	15.00	13.00	
		CH 165	5825	9.57	10.00	13.00	
	802.11ac-VHT40 MCS0	CH 151	5755	15.26	15.50	13.00	90.05
CH 159		5795	9.87	10.00	13.00		



Note:

- Per KDB 447498 D01v06, the 1-g SAR test exclusion thresholds for 100 MHz to 6 GHz at *test separation distances* ≤50 mm are determined by:

$[(\text{max. power of channel, including tune-up tolerance, mW}) / (\text{min. test separation distance, mm})] \cdot [\sqrt{f(\text{GHz})}] \leq 3.0$ for 1-g SAR, where

- $f(\text{GHz})$ is the RF channel transmit frequency in GHz
- Power and distance are rounded to the nearest mW and mm before calculation
- The result is rounded to one decimal place for comparison

Antenna	Frequency (GHz)	Max. Tune-up Power (dBm)	Max. Power (mW)	Test distance (mm)	Result	exclusion thresholds for 1-g SAR
ANT 0	5.755	12.50	17.78	10	4.27	3.0
ANT 1	5.755	16.50	44.67	10	10.72	3.0

- Per KDB 248227 D01v02r02, choose the highest output power channel to test SAR and determine further SAR exclusion.
- The output power of all data rate were pre-scan, just the worst case (the lowest data rate) of all mode were shown in report.
- Per KDB 248227 D01V02r02 section 2.2, when the EUT in continuously transmitting mode, the actual duty cycle is 100%, so the duty cycle factor is 1.

<2.4GHz WLAN ANT 0 + ANT 1>

	Mode	Channel	Frequency (MHz)	Duty Factor	Total Power with Duty Factor	Tune-Up Limit	Duty Cycle %
2.4GHz WLAN	802.11n-HT20 MCS0	CH 1	2412	0.22	15.77	16.00	95.07
		CH 6	2437	0.22	15.68	16.00	
		CH 11	2462	0.22	15.81	16.00	
	802.11n-HT40 MCS0	CH 3	2422	0.46	15.94	16.50	90.05
		CH 6	2437	0.46	15.88	16.50	
		CH 9	2452	0.46	16.03	16.50	



<5.2GHz WLAN ANT 0 + ANT 1>

	Mode	Channel	Frequency (MHz)	Duty Factor	Total Power with Duty Factor	Tune-Up Limit	Duty Cycle %
5.2GHz WLAN	802.11n- HT20 MCS0	CH 36	5180	0.24	15.23	15.50	94.58
		CH 44	5220	0.24	15.04	15.50	
		CH 48	5240	0.24	15.12	15.50	
	802.11n- HT40 MCS0	CH 38	5190	0.46	15.40	15.50	90.05
		CH 46	5230	0.46	15.44	15.50	
	802.11ac- VHT20 MCS0	CH 36	5180	0.22	14.06	14.50	95.07
		CH 44	5220	0.22	13.97	14.50	
		CH 48	5240	0.22	14.09	14.50	
	802.11ac- VHT40 MCS0	CH 38	5190	0.46	14.40	14.50	90.05
		CH 46	5230	0.46	14.51	14.50	

<5.8GHz WLAN ANT 0 + ANT 1>

	Mode	Channel	Frequency (MHz)	Duty Factor	Total Power with Duty Factor	Tune-Up Limit	Duty Cycle %
5.2GHz WLAN	802.11n- HT20 MCS0	CH 149	5745	0.24	17.35	17.50	94.58
		CH 157	5785	0.24	17.22	17.50	
		CH 165	5825	0.24	14.18	14.50	
	802.11n- HT40 MCS0	CH 151	5755	0.46	17.68	18.00	90.05
		CH 159	5795	0.46	14.48	15.00	
	802.11ac- VHT20 MCS0	CH 149	5745	0.22	16.38	16.50	95.07
		CH 157	5785	0.22	16.23	16.50	
		CH 165	5825	0.22	13.15	13.50	
	802.11ac- VHT40 MCS0	CH 151	5755	0.46	16.68	17.00	90.05
		CH 159	5795	0.46	13.58	14.00	

11 LTE Carrier Aggregation

This device supports Carrier Aggregation on downlink for inter. For the device supports bands and bandwidths and configurations are provided as follow table was according to 3GPP.

E-UTRA CA configuration	Downlink CA configurations (NOTE 3)	Component carriers in order of increasing carrier frequency			Maximum aggregated bandwidth [MHz]	Bandwidth combination set
		Channel bandwidths for carrier [MHz]	Channel bandwidths for carrier [MHz]	Channel bandwidths for carrier [MHz]		
CA_7C	CA_7C	15	15		40	0
		20	20			
		10	20		40	1
		15	15,20			
		20	10,15,20			
CA_7A-7A		5	15		40	0
		10	10,15			
		15	15,20			
		20	20			
CA_38C	CA_38C	15	15		40	0
		20	20			
CA_41C	CA_41C	10	20		40	0
		15	15, 20			
		20	10,15,20			
		5,10	20		40	1
		15	15, ,20			
		20	5,10,15,20			

Note:

1. According to KDB941225 D05A v01r02, Uplink maximum output power measurement with downlink carrier aggregation active should be measured, using the highest output channel measured without downlink carrier aggregation, to confirm that uplink maximum output power with downlink carrier aggregation active remains within the specified tune-up tolerance limits and not more than ¼ dB higher than the maximum output measured without downlink carrier aggregation active.
2. Uplink maximum output power with downlink carrier aggregation active does not show more than ¼ dB higher than the maximum output power without downlink carrier aggregation active,



therefore SAR evaluation with downlink carrier aggregation active can be excluded.

3. For power measurement were control and acknowledge data is sent on uplink channels that operate identical to specifications when downlink carrier aggregation is inactive.
4. Selected highest measured power when downlink carrier aggregation is inactive for conducted power comparison with downlink carrier aggregation is active, to confirm that when downlink carrier aggregation is active uplink maximum output power remains within the specified tune-up tolerance limits and not more than ¼ dB higher than the maximum output power measured when downlink carrier aggregation inactive.
5. For non-contiguous intra-band CA, the SCC selected to provide maximum separation from the PCC and must remain fully within the downlink transmission band.
6. For Intra-band, contiguous CA, the downlink channels selected to perform the uplink power measurement must satisfy
7. 3GPP channel spacing (5.4.1A of 3GPP TS 36.521 or equivalent) and channel bandwidth (5.4.2A) requirements.

$$\text{Nominal channel spacing} = \left\lceil \frac{BW_{\text{Channel}(1)} + BW_{\text{Channel}(2)} - 0.1|BW_{\text{Channel}(1)} - BW_{\text{Channel}(2)}|}{0.6} \right\rceil 0.3 \text{ [MHz]}$$

Two Carrier power verification:

PCC						SCC1					Power	
TDD-LTE Band	BW (MHz)	RB	Offset	UL Ch.	UL Freq. (MHz)	BW (MHz)	RB	Offset	DL Ch.	DL Freq. (MHz)	Tx Power With DL_CA	Releas Tx Power
intra-band CA (7C/38C/41C)												
Band 7	20	1	0	20850	2510	20	1	0	3048	2649.8	22.20	22.37
Band 7	20	1	0	21001	2525.1	20	1	0	3199	2664.9	21.94	22.48
Band 7	20	1	0	21152	2540.2	20	1	0	3350	2680	21.89	22.38
Band 38	20	1	0	37850	2580	20	1	0	38048	2599.8	23.55	23.39
Band 38	20	1	0	37901	2585.1	20	1	0	38099	2604.9	23.59	23.79
Band 38	20	1	0	37952	2590.2	20	1	0	38150	2610	23.44	23.32
Band 41	20	1	0	40340	2565	20	1	0	39948	2525.8	23.60	23.98
Band 41	20	1	0	40600	2591	20	1	0	40719	2602.9	23.54	23.92
Band 41	20	1	0	40870	23.43	20	1	0	41490	2680	23.05	23.43
intra-band CA (7A)												
Band 7	20	1	0	20850	2510	20	1	0	3350	2680	22.22	22.37
Band 7	20	1	0	21000	2525	20	1	0	3350	2680	21.96	22.48



12 Exposure Positions Consideration

12.1 EUT Antenna Location

Note: Please refer to Annex B

The main antenna 1 supports: WCDMA Band II/V, LTE Band 5;

The main antenna 2 supports: LTE Band 7/38/40/41;

12.2 Test Positions Consideration

Distance of Antennas to EUT edge/surface Test distance: 10mm						
Antennas	Back	Front	Top Side	Bottom Side	Right Side	Left Side
WCDMA/LTE	<25mm	<25mm	<25mm	<25mm	<25mm	<25mm
WLAN	<25mm	<25mm	<25mm	<25mm	<25mm	<25mm

Test Positions Test distance: 10mm						
Antennas	Back	Front	Top Side	Bottom Side	Right Side	Left Side
WCDMA/LTE	Yes	Yes	Yes	Yes	Yes	Yes
WLAN	Yes	Yes	Yes	Yes	Yes	Yes

Note:

1. Body mode SAR assessments are required.
2. Per KDB 447498 D01v06, for handsets the test separation distance is determined by the smallest distance between the outer surface of the device and the user, which is 10 mm for body SAR.

13 Block diagram of the tests to be performed

13.1 Head

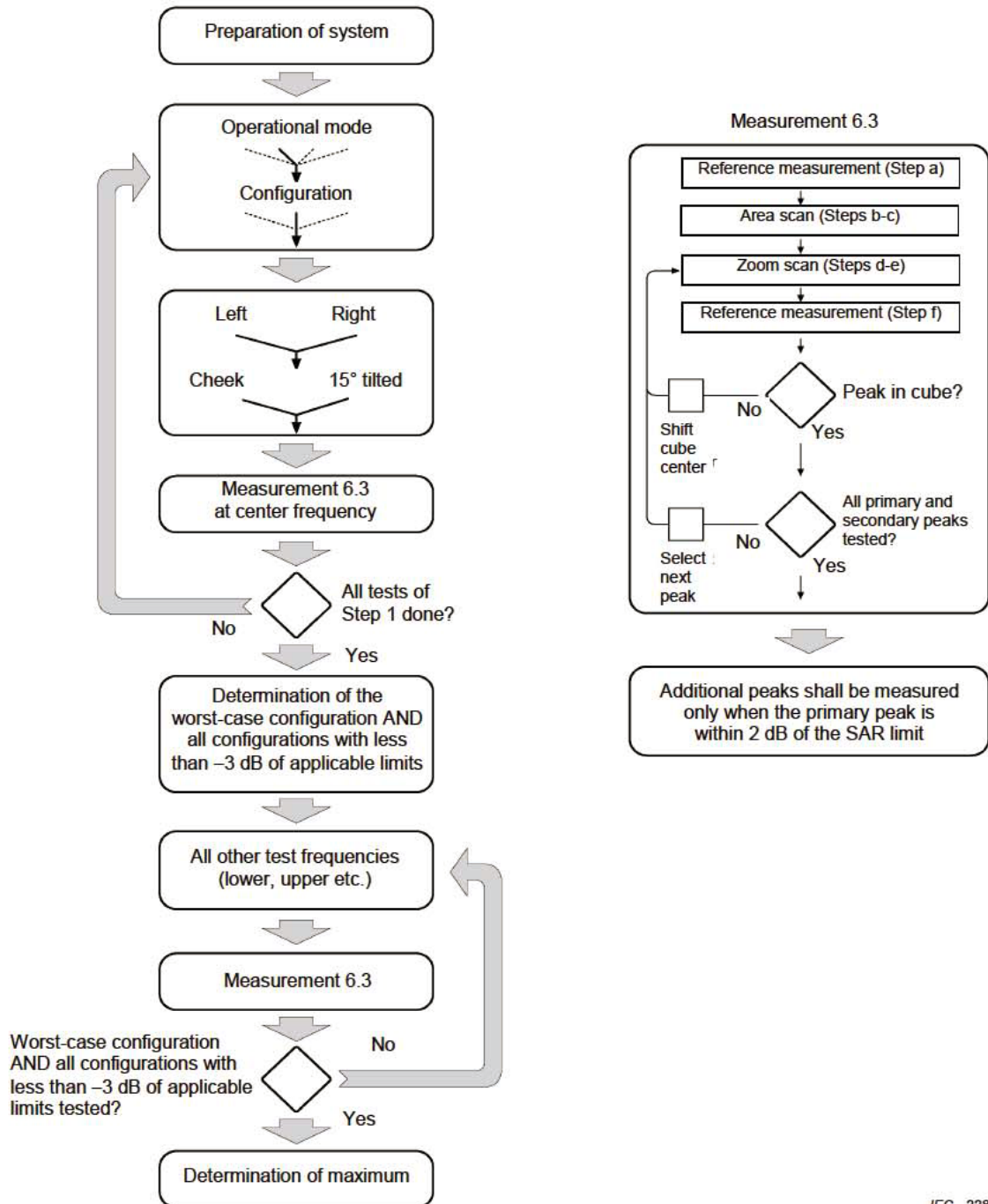

IEC 228/05

13.2 Body

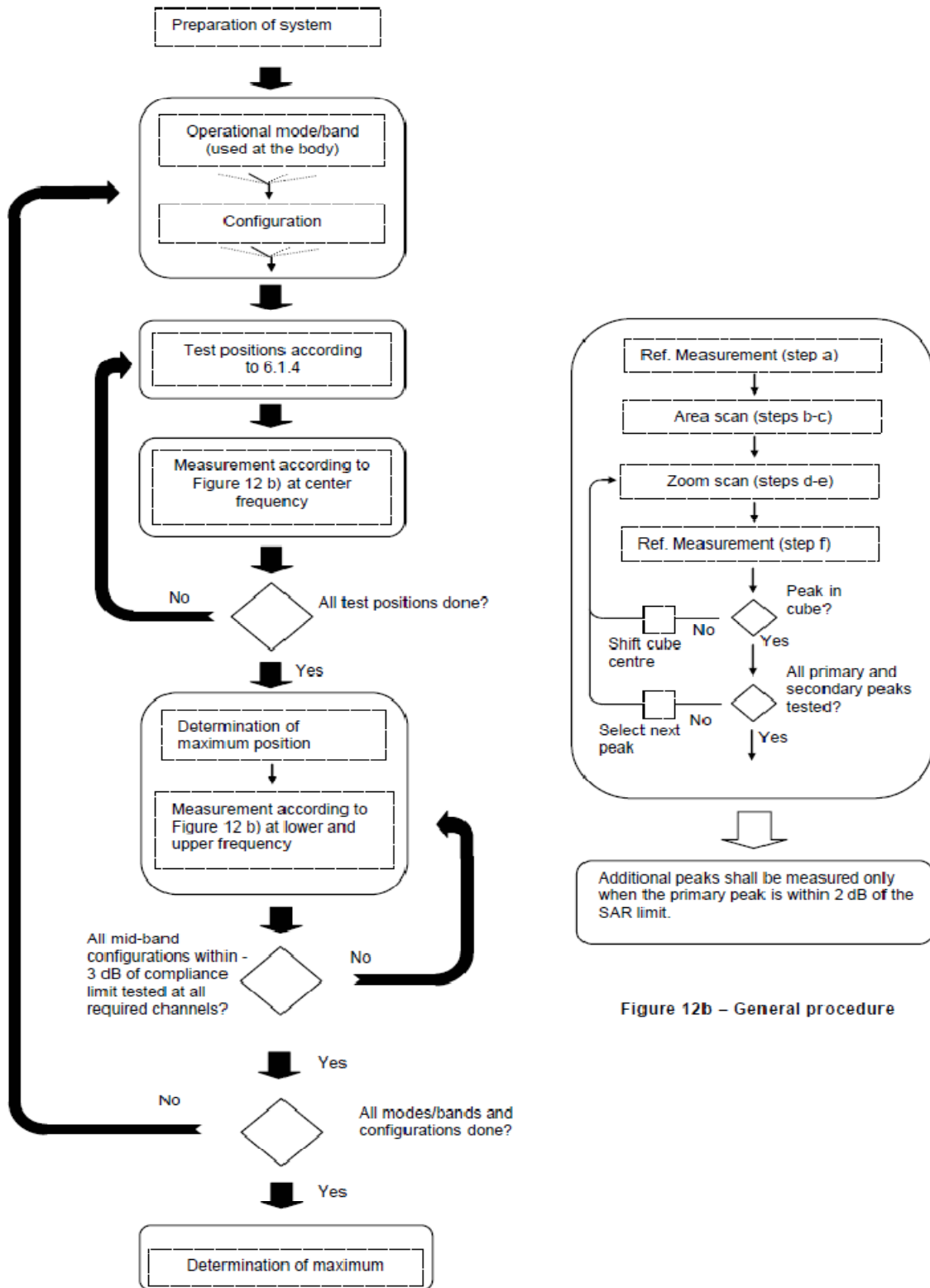

Figure 12b – General procedure



14 Test Guidance

1. The reported SAR is the measured SAR value adjusted for maximum tune-up tolerance.
 - a. Tune-up scaling Factor = tune-up limit power (mW) / EUT RF power (mW), where tune-up limit is the maximum rated power among all production units.
 - b. For SAR testing of WLAN signal with non-100% duty cycle, the measured SAR is scaled-up by the duty cycle scaling factor which is equal to "1/(duty cycle)"
 - c. For WWAN: Reported SAR(W/kg)= Measured SAR(W/kg)*Tune-up Scaling Factor
 - d. For WLAN/Bluetooth: Reported SAR(W/kg)= Measured SAR(W/kg)* Duty Cycle scaling factor * Tune-up scaling factor
2. Per KDB 447498 D01v06, for each exposure position, if the highest output power channel Reported SAR ≤ 0.8 W/kg, other channels SAR testing is not necessary.
3. Per KDB 865664 D01v01r04, for each frequency band, repeated SAR measurement is required when the measured SAR is ≥ 0.8 W/kg.
4. Per KDB 941225 D05v02r05, 100% RB allocation SAR measurement is not required when the highest reported SAR for 1 RB and 50% RB allocation are ≤ 0.8 W/kg.
5. Per KDB 248227 D01v02r02, for 802.11b DSSS , when the reported SAR of the highest measured maximum output power channel for the exposure configuration is ≤ 0.8 W/kg, no further SAR testing is required in that exposure configuration.
6. Per KDB 648474 D04v01r03, when the reported SAR for a body-worn accessory measured without a headset connected to the handset is ≤ 1.2 W/kg, SAR testing with a headset connected to the handset is not required.



15 SAR Test Results Summary

15.1 Standalone Body SAR

> WCDM Body SAR

Plot No.	Band/Mode	Test Position	CH.	Ave. Power (dBm)	Tune-up Limit (dBm)	Tune-up Scaling Factor	Meas. SAR _{1g} (W/kg)	Reported SAR _{1g} (W/kg)
1#	Band II/RMC	Front Side	9400	19.88	21.00	1.294	0.622	0.805
	Band II/RMC	Back Side	9400	19.88	21.00	1.294	0.385	0.498
	Band II/RMC	Left Side	9400	19.88	21.00	1.294	0.566	0.733
	Band II/RMC	Right Side	9400	19.88	21.00	1.294	0.043	0.056
	Band II/RMC	Top Side	9400	19.88	21.00	1.294	0.011	0.014
	Band II/RMC	Bottom Side	9400	19.88	21.00	1.294	0.214	0.277
	Band II/RMC	Front Side	9262	19.84	21.00	1.306	0.357	0.466
	Band II/RMC	Front Side	9538	19.81	21.00	1.315	0.557	0.733
2#	Band V/RMC	Front Side	4183	22.90	23.50	1.148	0.602	0.691
	Band V/RMC	Back Side	4183	22.90	23.50	1.148	0.284	0.326
	Band V/RMC	Left Side	4183	22.90	23.50	1.148	0.167	0.192
	Band V/RMC	Right Side	4183	22.90	23.50	1.148	0.101	0.116
	Band V/RMC	Top Side	4183	22.90	23.50	1.148	0.220	0.253
	Band V/RMC	Bottom Side	4183	22.90	23.50	1.148	0.183	0.210

> FDD-LTE QPSK Body SAR

Plot No.	Band/Mode	Test Position	CH.	Ave. Power (dBm)	Tune-up Limit (dBm)	Tune-up Scaling Factor	Meas. SAR _{1g} (W/kg)	Reported SAR _{1g} (W/kg)
3#	LTE Band 5/1RB#0 10M	Front Side	20525	22.32	23.00	1.169	0.665	0.778
	LTE Band 5/1RB#0 10M	Back Side	20525	22.32	23.00	1.169	0.381	0.446
	LTE Band 5/1RB#0 10M	Left Side	20525	22.32	23.00	1.169	0.054	0.063
	LTE Band 5/1RB#0 10M	Right Side	20525	22.32	23.00	1.169	0.226	0.264
	LTE Band 5/1RB#0 10M	Top Side	20525	22.32	23.00	1.169	0.176	0.206
	LTE Band 5/1RB#0 10M	Bottom Side	20525	22.32	23.00	1.169	0.345	0.403
	LTE Band 5/25RB#12 10M	Front Side	20525	21.17	22.00	1.211	0.545	0.660
	LTE Band 5/25RB#12 10M	Back Side	20525	21.17	22.00	1.211	0.306	0.370
	LTE Band 5/25RB#12 10M	Left Side	20525	21.17	22.00	1.211	0.133	0.161
	LTE Band 5/25RB#12 10M	Right Side	20525	21.17	22.00	1.211	0.031	0.038
	LTE Band 5/25RB#12 10M	Top Side	20525	21.17	22.00	1.211	0.100	0.120
	LTE Band 5/25RB#12 10M	Bottom Side	20525	21.17	22.00	1.211	0.208	0.252
	LTE Band 7/1RB#0 20M	Front Side	21100	22.48	23.00	1.127	0.733	0.826
	LTE Band 7/1RB#0 20M	Back Side	21100	22.48	23.00	1.127	0.214	0.241
	LTE Band 7/1RB#0 20M	Left Side	21100	22.48	23.00	1.127	0.161	0.181
	LTE Band 7/1RB#0 20M	Right Side	21100	22.48	23.00	1.127	0.080	0.090
	LTE Band 7/1RB#0 20M	Top Side	21100	22.48	23.00	1.127	0.518	0.584
	LTE Band 7/1RB#0 20M	Bottom Side	21100	22.48	23.00	1.127	0.063	0.071



4#	LTE Band 7/1RB#0 20M	Front Side	20850	22.37	23.00	1.156	0.748	0.865
	LTE Band 7/1RB#0 20M	Front Side	21350	22.38	23.00	1.153	0.681	0.786
	LTE Band 7/100RB#0 20M	Front Side	21100	21.09	22.00	1.233	0.532	0.656
	LTE Band 7/50RB#0 20M	Front Side	21100	21.45	22.00	1.135	0.554	0.629
	LTE Band 7/50RB#0 20M	Back Side	21100	21.45	22.00	1.135	0.171	0.194
	LTE Band 7/50RB#0 20M	Left Side	21100	21.45	22.00	1.135	0.282	0.320
	LTE Band 7/50RB#0 20M	Right Side	21100	21.45	22.00	1.135	0.041	0.047
	LTE Band 7/50RB#0 20M	Top Side	21100	21.45	22.00	1.135	0.227	0.258
	LTE Band 7/50RB#0 20M	Bottom Side	21100	21.45	22.00	1.135	0.029	0.033

➤ TDD-LTE QPSK Body SAR

Plot No.	Band/Mode	Test Position	CH.	Ave. Power (dBm)	Tune-up Limit (dBm)	Tune-up Scaling Factor	Meas. SAR _{1g} (W/kg)	Reported SAR _{1g} (W/kg)
5#	LTE Band 38/1RB#0 20M	Front Side	38000	23.79	24.00	1.050	0.415	0.438
	LTE Band 38/1RB#0 20M	Back Side	38000	23.79	24.00	1.050	0.084	0.089
	LTE Band 38/1RB#0 20M	Left Side	38000	23.79	24.00	1.050	0.196	0.207
	LTE Band 38/1RB#0 20M	Right Side	38000	23.79	24.00	1.050	0.011	0.012
	LTE Band 38/1RB#0 20M	Top Side	38000	23.79	24.00	1.050	0.171	0.181
	LTE Band 38/1RB#0 20M	Bottom Side	38000	23.79	24.00	1.050	0.020	0.021
	LTE Band 38/50RB#0 20M	Front Side	38000	22.61	23.00	1.094	0.350	0.385
	LTE Band 38/50RB#0 20M	Back Side	38000	22.61	23.00	1.094	0.117	0.129
	LTE Band 38/50RB#0 20M	Left Side	38000	22.61	23.00	1.094	0.189	0.208
	LTE Band 38/50RB#0 20M	Right Side	38000	22.61	23.00	1.094	0.012	0.013
	LTE Band 38/50RB#0 20M	Top Side	38000	22.61	23.00	1.094	0.120	0.132
	LTE Band 38/50RB#0 20M	Bottom Side	38000	22.61	23.00	1.094	0.019	0.021
6#	LTE Band 40A/1RB#0 10M	Front Side	38750	22.91	23.50	1.146	0.556	0.641
	LTE Band 40A/1RB#0 10M	Back Side	38750	22.91	23.50	1.146	0.125	0.144
	LTE Band 40A/1RB#0 10M	Left Side	38750	22.91	23.50	1.146	0.129	0.149
	LTE Band 40A/1RB#0 10M	Right Side	38750	22.91	23.50	1.146	0.027	0.031
	LTE Band 40A/1RB#0 10M	Top Side	38750	22.91	23.50	1.146	0.409	0.471
	LTE Band 40A/1RB#0 10M	Bottom Side	38750	22.91	23.50	1.146	0.029	0.033
	LTE Band 40A/25RB#0 10M	Front Side	38750	21.70	22.50	1.202	0.415	0.502
	LTE Band 40A/25RB#0 10M	Back Side	38750	21.70	22.50	1.202	0.135	0.163
	LTE Band 40A/25RB#0 10M	Left Side	38750	21.70	22.50	1.202	0.100	0.121
	LTE Band 40A/25RB#0 10M	Right Side	38750	21.70	22.50	1.202	0.024	0.028
	LTE Band 40A/25RB#0 10M	Top Side	38750	21.70	22.50	1.202	0.322	0.389
	LTE Band 40A/25RB#0 10M	Bottom Side	38750	21.70	22.50	1.202	0.024	0.029
7#	LTE Band 40B/1RB#25 10M	Front Side	39200	22.91	23.50	1.146	0.468	0.539
	LTE Band 40B/1RB#25 10M	Back Side	39200	22.91	23.50	1.146	0.178	0.205
	LTE Band 40B/1RB#25 10M	Left Side	39200	22.91	23.50	1.146	0.129	0.149
	LTE Band 40B/1RB#25 10M	Right Side	39200	22.91	23.50	1.146	0.018	0.021
	LTE Band 40B/1RB#25 10M	Top Side	39200	22.91	23.50	1.146	0.389	0.449
	LTE Band 40B/1RB#25 10M	Bottom Side	39200	22.91	23.50	1.146	0.038	0.044



	LTE Band 40B/25RB#0 10M	Front Side	39200	21.90	22.50	1.148	0.428	0.494
	LTE Band 40B/25RB#0 10M	Back Side	39200	21.90	22.50	1.148	0.150	0.173
	LTE Band 40B/25RB#0 10M	Left Side	39200	21.90	22.50	1.148	0.109	0.126
	LTE Band 40B/25RB#0 10M	Right Side	39200	21.90	22.50	1.148	0.016	0.019
	LTE Band 40B/25RB#0 10M	Top Side	39200	21.90	22.50	1.148	0.315	0.364
	LTE Band 40B/25RB#0 10M	Bottom Side	39200	21.90	22.50	1.148	0.032	0.037
8#	LTE Band 41/1RB#0 20M	Front Side	40340	23.98	24.00	1.005	0.515	0.520
	LTE Band 41/1RB#0 20M	Back Side	40340	23.98	24.00	1.005	0.077	0.078
	LTE Band 41/1RB#0 20M	Left Side	40340	23.98	24.00	1.005	0.232	0.234
	LTE Band 41/1RB#0 20M	Right Side	40340	23.98	24.00	1.005	0.011	0.011
	LTE Band 41/1RB#0 20M	Top Side	40340	23.98	24.00	1.005	0.168	0.170
	LTE Band 41/1RB#0 20M	Bottom Side	40340	23.98	24.00	1.005	0.022	0.022
	LTE Band 41/50RB#0 20M	Front Side	40340	22.83	23.00	1.040	0.381	0.399
	LTE Band 41/50RB#0 20M	Back Side	40340	22.83	23.00	1.040	0.101	0.106
	LTE Band 41/50RB#0 20M	Left Side	40340	22.83	23.00	1.040	0.169	0.177
	LTE Band 41/50RB#0 20M	Right Side	40340	22.83	23.00	1.040	0.015	0.016
	LTE Band 41/50RB#0 20M	Top Side	40340	22.83	23.00	1.040	0.115	0.120
	LTE Band 41/50RB#0 20M	Bottom Side	40340	22.83	23.00	1.040	0.018	0.019

Note: The LTE TDD Reported 1g SAR (W/kg) has been calculated together with the duty cycle scaling factor.

➤ **WLAN Body SAR**

Plot No.	Band/Mode	Test Position	CH.	Ave. Power (dBm)	Tune-up Limit (dBm)	Tune-up Scaling Factor	Meas. SAR _{1g} (W/kg)	Reported SAR _{1g} (W/kg)
Ant.0								
	WLAN2.4GHz/802.11b	Front Side	11	15.59	16.00	1.099	0.025	0.028
	WLAN2.4GHz/802.11b	Back Side	11	15.59	16.00	1.099	0.014	0.015
	WLAN2.4GHz/802.11b	Left Side	11	15.59	16.00	1.099	0.007	0.008
	WLAN2.4GHz/802.11b	Right Side	11	15.59	16.00	1.099	0.012	0.013
	WLAN2.4GHz/802.11b	Top Side	11	15.59	16.00	1.099	0.007	0.007
	WLAN2.4GHz/802.11b	Bottom Side	11	15.59	16.00	1.099	0.007	0.008
Ant.1								
	WLAN2.4GHz/802.11b	Front Side	11	15.28	16.00	1.180	0.065	0.077
9#	WLAN2.4GHz/802.11b	Back Side	11	15.28	16.00	1.180	0.084	0.100
	WLAN2.4GHz/802.11b	Left Side	11	15.28	16.00	1.180	0.050	0.060
	WLAN2.4GHz/802.11b	Right Side	11	15.28	16.00	1.180	0.079	0.095
	WLAN2.4GHz/802.11b	Top Side	11	15.28	16.00	1.180	0.025	0.030
	WLAN2.4GHz/802.11b	Bottom Side	11	15.28	16.00	1.180	0.020	0.024
Ant.0								
10#	WLAN5.2GHz/802.11n-40	Front Side	46	12.49	13.00	1.125	0.080	0.095
	WLAN5.2GHz/802.11n-40	Back Side	46	12.49	13.00	1.125	0.032	0.038
	WLAN5.2GHz/802.11n-40	Left Side	46	12.49	13.00	1.125	0.031	0.036
	WLAN5.2GHz/802.11n-40	Right Side	46	12.49	13.00	1.125	0.029	0.035
	WLAN5.2GHz/802.11n-40	Top Side	46	12.49	13.00	1.125	0.029	0.034
	WLAN5.2GHz/802.11n-40	Bottom Side	46	12.49	13.00	1.125	0.030	0.035
Ant.1								



	WLAN5.2GHz/802.11n-40	Front Side	46	12.26	12.50	1.057	0.015	0.016
	WLAN5.2GHz/802.11n-40	Back Side	46	12.26	12.50	1.057	0.033	0.037
	WLAN5.2GHz/802.11n-40	Left Side	46	12.26	12.50	1.057	0.031	0.034
	WLAN5.2GHz/802.11n-40	Right Side	46	12.26	12.50	1.057	0.030	0.034
	WLAN5.2GHz/802.11n-40	Top Side	46	12.26	12.50	1.057	0.028	0.031
	WLAN5.2GHz/802.11n-40	Bottom Side	46	12.26	12.50	1.057	0.027	0.030
Ant.0								
	WLAN5.8GHz/802.11n-40	Front Side	151	11.94	12.50	1.138	0.312	0.38
	WLAN5.8GHz/802.11n-40	Back Side	151	11.94	12.50	1.138	0.163	0.195
	WLAN5.8GHz/802.11n-40	Left Side	151	11.94	12.50	1.138	0.345	0.413
	WLAN5.8GHz/802.11n-40	Right Side	151	11.94	12.50	1.138	0.082	0.098
11#	WLAN5.8GHz/802.11n-40	Top Side	151	11.94	12.50	1.138	0.750	0.898
	WLAN5.8GHz/802.11n-40	Bottom Side	151	11.94	12.50	1.138	0.064	0.077
Ant.1								
	WLAN5.8GHz/802.11n-40	Front Side	151	16.28	16.50	1.052	0.281	0.311
	WLAN5.8GHz/802.11n-40	Back Side	151	16.28	16.50	1.052	0.049	0.055
	WLAN5.8GHz/802.11n-40	Left Side	151	16.28	16.50	1.052	0.323	0.358
	WLAN5.8GHz/802.11n-40	Right Side	151	16.28	16.50	1.052	0.043	0.047
	WLAN5.8GHz/802.11n-40	Top Side	151	16.28	16.50	1.052	0.093	0.103
	WLAN5.8GHz/802.11n-40	Bottom Side	151	16.28	16.50	1.052	0.045	0.050

Note:

1. Per KDB 447498 D01v06, for each exposure position, if the highest output power channel Reported SAR $\leq 0.8\text{W/kg}$, other channels SAR testing is not necessary.
2. Per KDB 865664 D01v01r04, for each frequency band, repeated SAR measurement is required when the measured SAR is $\geq 0.8\text{W/kg}$.
3. Per KDB 941225 D05v02r05, 100% RB allocation SAR measurement is not required when the highest reported SAR for 1 RB and 50% RB allocation are $\leq 0.8\text{ W/kg}$.
4. Per KDB 248227 D01v02r02, for 802.11b DSSS , when the reported SAR of the highest measured maximum output power channel for the exposure configuration is $\leq 0.8\text{ W/kg}$, no further SAR testing is required in that exposure configuration.
5. Per KDB 248227 D01v02r02, OFDM SAR is not required when the highest reported SAR for DSSS is adjusted by the ratio of OFDM to DSSS specified maximum output power and the adjusted SAR is $\leq 1.2\text{ W/kg}$. Cuz the maximum output power specified for OFDM and DSSS are 32.14mW(15.07dBm) and 36.22mW(15.59dBm), the scaled SAR would be $0.093 \times (32.14/36.22)=0.083\text{W/Kg}<1.2\text{W/kg}$, therefore, SAR is not required for OFDM.
6. According to KDB 865664 D02v01r02, SAR plot is required for the highest measured SAR in each exposure configuration, wireless mode and frequency band combination.
7. The WLAN 2.4GHz Reported 1g SAR (W/kg) has been calculated together with the duty cycle scaling factor 1.010.
8. The WLAN 5GHz Reported 1g SAR (W/kg) has been calculated together with the duty cycle scaling factor 1.053.

16 Multi-Band Simultaneous Transmission Considerations

➤ Simultaneous Transmission Capabilities

According to FCC KDB Publication 447498 D01v06, transmitters are considered to be transmitting simultaneously when there is overlapping transmission, with the exception of transmissions during network hand-offs with maximum hand-off duration less than 30 seconds. Possible transmission paths for the EUT are shown in below Figure and are color-coded to indicate communication modes which share the same path. Modes which share the same transmission path cannot transmit simultaneously with one another.

Fig.15.1 Simultaneous Transmission Paths

➤ Multi-Band simultaneous Transmission Consideration

Simultaneous Transmission Consideration	Position	Applicable Combination	
	Body		WWAN+WLAN 2.4GHz
			WWAN+WLAN 5GHz
			WLAN 2.4GHz Ant 0+WLAN 2.4GHz Ant 1
			WLAN 5GHz Ant 0+WLAN 5GHz Ant 1
			WWAN + 2.4GHz(MIMO)
			WWAN + 5GHz(MIMO)

Note:

1. WCDMA/LTE shares the same antenna, and cannot transmit simultaneously.
2. The Report SAR summation is calculated based on the same configuration and test position.
3. Per KDB 447498 D01v06, simultaneous transmission SAR is compliant if,
 - i. Scalar SAR summation < 1.6W/kg.
 - ii. $SPLSR = (SAR_1 + SAR_2)^{1.5} / (min. separation distance, mm)$, and the peak separation distance is determined from the square root of $[(x_1-x_2)^2 + (y_1-y_2)^2 + (z_1-z_2)^2]$, where (x_1, y_1, z_1) and (x_2, y_2, z_2) are the coordinates of the extrapolated peak SAR locations in the zoom scan If $SPLSR \leq 0.04$, simultaneously transmission SAR measurement is not necessary
 - iii. Simultaneously transmission SAR measurement, and the Reported multi-band SAR < 1.6W/kg



16.1 SAR Simultaneous Transmission Analysis

➤ **Body Simultaneous Transmission**

WWAN Band		Exposure Position	1	2	3	1+2 Summed 1g SAR (W/kg)	1+3 Summed 1g SAR (W/kg)
			WWAN 1g SAR (W/kg)	2.4GHz WLAN 1g SAR (W/kg)	5GHz WLAN 1g SAR (W/kg)		
WCDMA	WCDMA Band II	Front side	0.805	0.077	0.38	0.882	1.185
		Back side	0.498	0.100	0.195	0.598	0.693
		Left side	0.733	0.060	0.413	0.793	1.146
		Right side	0.056	0.095	0.098	0.151	0.154
		Top side	0.014	0.030	0.898	0.044	0.912
		Bottom side	0.277	0.024	0.077	0.301	0.354
	WCDMA Band V	Front side	0.691	0.077	0.38	0.768	1.071
		Back side	0.326	0.100	0.195	0.426	0.521
		Left side	0.192	0.060	0.413	0.252	0.605
		Right side	0.116	0.095	0.098	0.211	0.214
		Top side	0.253	0.030	0.898	0.283	1.151
		Bottom side	0.210	0.024	0.077	0.234	0.287
LTE	LTE Band 5	Front side	0.778	0.077	0.38	0.855	1.158
		Back side	0.446	0.100	0.195	0.546	0.641
		Left side	0.161	0.060	0.413	0.221	0.574
		Right side	0.264	0.095	0.098	0.359	0.362
		Top side	0.206	0.030	0.898	0.236	1.104
		Bottom side	0.403	0.024	0.077	0.427	0.480
	LTE Band 7	Front side	0.865	0.077	0.38	0.942	1.245
		Back side	0.241	0.100	0.195	0.341	0.436
		Left side	0.320	0.060	0.413	0.380	0.733
		Right side	0.090	0.095	0.098	0.185	0.188
		Top side	0.584	0.030	0.898	0.614	1.482
		Bottom side	0.071	0.024	0.077	0.095	0.148
	LTE Band 38	Front side	0.438	0.077	0.38	0.515	0.818
		Back side	0.129	0.100	0.195	0.229	0.324
		Left side	0.208	0.060	0.413	0.268	0.621
		Right side	0.013	0.095	0.098	0.108	0.111
		Top side	0.181	0.030	0.898	0.211	1.079
		Bottom side	0.021	0.024	0.077	0.045	0.098
	LTE Band 40	Front side	0.641	0.077	0.38	0.718	1.021
		Back side	0.205	0.100	0.195	0.305	0.400
		Left side	0.149	0.060	0.413	0.209	0.562
		Right side	0.031	0.095	0.098	0.126	0.129

		Top side	0.471	0.030	0.898	0.501	1.369
		Bottom side	0.044	0.024	0.077	0.068	0.121
	LTE Band 41	Front side	0.520	0.077	0.38	0.597	0.90
		Back side	0.106	0.100	0.195	0.206	0.301
		Left side	0.234	0.060	0.413	0.294	0.647
		Right side	0.016	0.095	0.098	0.111	0.114
		Top side	0.170	0.030	0.898	0.200	1.068
		Bottom side	0.022	0.024	0.077	0.046	0.099

➤ **WLAN MIMO Simultaneous Transmission**

WLAN Band		Exposure Position	1	2	1+2 Summed 10g SAR (W/kg)
			Ant 0 10g SAR (W/kg)	Ant 1 10g SAR (W/kg)	
2.4GHz	2.4GHz WLAN	Front side	0.028	0.077	0.105
		Back side	0.015	0.100	0.115
		Left side	0.008	0.060	0.068
		Right side	0.013	0.095	0.108
		Top side	0.007	0.030	0.037
		Bottom side	0.008	0.024	0.032
5GHz	5.2GHz WLAN	Front side	0.095	0.016	0.111
		Back side	0.038	0.037	0.075
		Left side	0.036	0.034	0.070
		Right side	0.035	0.034	0.069
		Top side	0.034	0.031	0.065
		Bottom side	0.035	0.030	0.065
	5.8GHz WLAN	Front side	0.679	0.311	0.990
		Back side	0.195	0.055	0.250
		Left side	0.413	0.358	0.771
		Right side	0.098	0.047	0.145
		Top side	0.898	0.103	1.001
		Bottom side	0.077	0.050	0.127

➤ **WWAN + WLAN MIMO Simultaneous Transmission**



WWAN Band	Exposure Position	1	2	3	4	5	1+2+3 Summed 1g SAR (W/kg)	1+4+5 Summed 1g SAR (W/kg)
		WWAN	2.4GHz WLAN Ant 0	2.4GHz WLAN Ant 1	5GHz WLAN Ant 0	5GHz WLAN Ant 1		
		1g SAR (W/kg)	1g SAR (W/kg)	1g SAR (W/kg)	1g SAR (W/kg)	1g SAR (W/kg)		
WCDMA Band II	Front	0.805	0.028	0.077	0.380	0.311	0.910	1.496
	Back	0.498	0.015	0.100	0.195	0.055	0.613	0.748
	Left side	0.733	0.008	0.060	0.413	0.358	0.801	1.504
	Right side	0.056	0.013	0.095	0.098	0.047	0.164	0.201
	Top side	0.014	0.007	0.030	0.898	0.103	0.051	1.015
	Bottom side	0.277	0.008	0.024	0.077	0.050	0.309	0.404
WCDMA Band V	Front	0.691	0.028	0.077	0.380	0.311	0.796	1.382
	Back	0.326	0.015	0.100	0.195	0.055	0.441	0.576
	Left side	0.192	0.008	0.060	0.413	0.358	0.260	0.963
	Right side	0.116	0.013	0.095	0.098	0.047	0.224	0.261
	Top side	0.253	0.007	0.030	0.898	0.103	0.290	1.254
	Bottom side	0.210	0.008	0.024	0.077	0.050	0.242	0.337
LTE Band 5	Front	0.778	0.028	0.077	0.380	0.311	0.883	1.469
	Back	0.446	0.015	0.100	0.195	0.055	0.561	0.696
	Left side	0.161	0.008	0.060	0.413	0.358	0.229	0.932
	Right side	0.264	0.013	0.095	0.098	0.047	0.372	0.409
	Top side	0.206	0.007	0.030	0.898	0.103	0.243	1.207
	Bottom side	0.403	0.008	0.024	0.077	0.050	0.435	0.530
LTE Band 7	Front	0.865	0.028	0.077	0.380	0.311	0.970	1.556
	Back	0.241	0.015	0.100	0.195	0.055	0.356	0.491
	Left side	0.320	0.008	0.060	0.413	0.358	0.388	1.091
	Right side	0.090	0.013	0.095	0.098	0.047	0.198	0.235
	Top side	0.584	0.007	0.030	0.898	0.103	0.621	1.585
	Bottom side	0.071	0.008	0.024	0.077	0.050	0.103	0.198
LTE Band 38	Front	0.438	0.028	0.077	0.380	0.311	0.543	1.129
	Back	0.129	0.015	0.100	0.195	0.055	0.244	0.379
	Left side	0.208	0.008	0.060	0.413	0.358	0.276	0.979
	Right side	0.013	0.013	0.095	0.098	0.047	0.121	0.158
	Top side	0.181	0.007	0.030	0.898	0.103	0.218	1.182
	Bottom side	0.021	0.008	0.024	0.077	0.050	0.053	0.148
LTE Band 40	Front	0.641	0.028	0.077	0.380	0.311	0.746	1.332
	Back	0.205	0.015	0.100	0.195	0.055	0.320	0.455
	Left side	0.149	0.008	0.060	0.413	0.358	0.217	0.920
	Right side	0.031	0.013	0.095	0.098	0.047	0.139	0.176
	Top side	0.471	0.007	0.030	0.898	0.103	0.508	1.472
	Bottom side	0.044	0.008	0.024	0.077	0.050	0.076	0.171



WWAN Band	Exposure Position	1	2	3	4	5	1+2+3 Summed 1g SAR (W/kg)	1+4+5 Summed 1g SAR (W/kg)
		WWAN	2.4GHz WLAN Ant 0	2.4GHz WLAN Ant 1	5GHz WLAN Ant 0	5GHz WLAN Ant 1		
		1g SAR (W/kg)	1g SAR (W/kg)	1g SAR (W/kg)	1g SAR (W/kg)	1g SAR (W/kg)		
LTE Band 41	Front	0.520	0.028	0.077	0.380	0.311	0.625	1.211
	Back	0.106	0.015	0.100	0.195	0.055	0.221	0.356
	Left side	0.234	0.008	0.060	0.413	0.358	0.302	1.005
	Right side	0.016	0.013	0.095	0.098	0.047	0.124	0.161
	Top side	0.170	0.007	0.030	0.898	0.103	0.207	1.171
	Bottom side	0.022	0.008	0.024	0.077	0.050	0.054	0.149



17 Measurement Uncertainty

The component of uncertainty may generally be categorized according to the methods used to evaluate them. The evaluation of uncertainty by the statistical analysis of a series of observations is termed a Type A evaluation of uncertainty. The evaluation of uncertainty by means other than the statistical analysis of a series of observation is termed a Type B evaluation of uncertainty. Each component of uncertainty, however evaluated, is represented by an estimated standard deviation, termed standard uncertainty, which is determined by the positive square root of the estimated variance.

A Type A evaluation of standard uncertainty may be based on any valid statistical method for treating data. This includes calculating the standard deviation of the mean of a series of independent observations; using the method of least squares to fit a curve to the data in order to estimate the parameter of the curve and their standard deviations; or carrying out an analysis of variance in order to identify and quantify random effects in certain kinds of measurement.

A Type B evaluation of standard uncertainty is typically based on scientific judgment using all of the relevant information available. These may include previous measurement data, experience, and knowledge of the behavior and properties of relevant materials and instruments, manufacture’s specification, data provided in calibration reports and uncertainties assigned to reference data taken from handbooks. Broadly speaking, the uncertainty is either obtained from an outdoor source or obtained from an assumed distribution, such as the normal distribution, rectangular or triangular distributions indicated in below Table.

Uncertainty Distributions	Normal	Rectangular	Triangular	U-Shape
Multi-plying Factor	1/k(b)	$1/\sqrt{3}$	$1/\sqrt{6}$	$1/\sqrt{2}$

Standard Uncertainty for Assumed Distribution

The combined standard uncertainty of the measurement result represents the estimated standard deviation of the result. It is obtained by combining the individual standard uncertainties of both Type A and Type B evaluation using the usual “root-sum-squares” (RSS) methods of combining standard deviations by taking the positive square root of the estimated variances.

Expanded uncertainty is a measure of uncertainty that defines an interval about the measurement result within which the measured value is confidently believed to lie. It is obtained by multiplying the combined standard uncertainty by a coverage factor. Typically, the coverage factor ranges from 2 to 3. Using a coverage factor allows the true value of a measured quantity to be specified with a defined probability within the specified uncertainty range. For purpose of this document, a coverage factor two is used, which corresponds to confidence interval of about 95 %. The DASY uncertainty Budget is shown in the following tables.



a	b	c	d	e= f(d,k)	f	g	h= c*f/e	i= c*g/e	k
Uncertainty Component	Sec.	Tol (+-%)	Prob. Dist.	Div.	Ci (1g)	Ci (10g)	1g Ui (+-%)	10g Ui (+-%)	Vi
Measurement System									
Probe calibration	E.2.1	5.83	N	1	1	1	5.83	5.83	∞
Axial Isotropy	E.2.2	3.5	R	$\sqrt{3}$	1	1	2.02	2.02	∞
Hemispherical Isotropy	E.2.2	5.9	R	$\sqrt{3}$	1	1	3.41	3.41	∞
Boundary effect	E.2.3	1.0	R	$\sqrt{3}$	1	1	0.58	0.58	∞
Linearity	E.2.4	4.7	R	$\sqrt{3}$	1	1	2.71	2.71	∞
System detection limits	E.2.5	1.0	R	$\sqrt{3}$	1	1	0.58	0.58	∞
Readout Electronics	E.2.6	0.5	N	1	1	1	0.5	0.5	∞
Reponse Time	E.2.7	3.0	R	$\sqrt{3}$	1	1	3.0	3.0	∞
Integration Time	E.2.8	1.4	R	$\sqrt{3}$	1	1	0.81	0.81	∞
RF ambient Conditions	E.6.1	3.0	R	$\sqrt{3}$	1	1	1.73	1.73	∞
Probe positioner Mechanical Tolerance	E.6.2	1.4	R	$\sqrt{3}$	1	1	0.81	0.81	∞
Probe positioning with respect to Phantom Shell	E.6.3	1.4	R	$\sqrt{3}$	1	1	0.81	0.81	∞
Extrapolation, interpolation and integration Algorithms for Max. SAR Evaluation	E.5.2	2.3	R	$\sqrt{3}$	1	1	1.33	1.33	∞
Test sample Related									
Test sample positioning	E.4.2. 1	2.6	N	1	1	1	2.6	2.6	N-1
Device Holder Uncertainty	E.4.1. 1	3.0	N	1	1	1	5.11	5.11	∞
Output power Power drift - SAR drift measurement	6.6.2	5.0	R	$\sqrt{3}$	1	1	2.89	2.89	∞
Phantom and Tissue Parameters									
Phantom Uncertainty (Shape and thickness tolerances)	E.3.1	4.0	R	$\sqrt{3}$	1	1	2.31	2.31	∞
Liquid conductivity - deviation from target value	E.3.2	2.0	R	$\sqrt{3}$	0.6 4	0.43	1.69	1.13	∞
Liquid conductivity - measurement uncertainty	E.3.3	2.5	N	1	0.6 4	0.43	3.20	2.15	M
Liquid permittivity - deviation from target value	E.3.2	2.5	R	$\sqrt{3}$	0.6	0.49	1.28	1.04	∞
Liquid permittivity - measurement uncertainty	E.3.3	5.0	N	1	0.6	0.49	6.00	4.90	M
Liquid conductivity – temperature uncertainty	E.3.4		R	$\sqrt{3}$	0.7 8	0.41			∞
Liquid permittivity – temperature uncertainty	E.3.4		R	$\sqrt{3}$	0.2 3	0.26			∞
Combined Standard Uncertainty			RSS				11.55	12.07	



Expanded Uncertainty (95% Confidence interval)			K=2				±23.20	±24.17	
---	--	--	-----	--	--	--	--------	--------	--

18 Measurement Conclusion

The SAR evaluation indicates that the EUT complies with the RF radiation exposure limits of the India, with respect to all parameters subject to this test. These measurements were taken to simulate the RF effects of RF exposure under worst-case conditions. Precise laboratory measures were taken to assure repeatability of the tests. The results and statements relate only to the item(s) tested. Please note that the absorption and distribution of electromagnetic energy in the body are very complex phenomena that depend on the mass, shape, and size of the body, the orientation of the body with respect to the field vectors, and the electrical properties of both the body and the environment. Other variables that may play a substantial role in possible biological effects are those that characterize the environment (e.g. ambient temperature, air velocity, relative humidity, and body insulation) and those that characterize the individual (e.g. age, gender, activity level, debilitation, or disease). Because various factors may interact with one another to vary the specific biological outcome of an exposure to electromagnetic fields, any protection guide should consider maximal amplification of biological effects as a result of field-body interactions, environmental conditions, and physiological variables.



Annex A General Information

1. Identification of the Responsible Testing Laboratory

Laboratory Name:	Shenzhen Morlab Communications Technology Co., Ltd. Morlab Laboratory
Laboratory Address:	FL.3, Building A, FeiYang Science Park, No.8 LongChang Road, Block 67, BaoAn District, ShenZhen, GuangDong Province, P. R. China
Telephone:	+86 755 36698555
Facsimile:	+86 755 36698525

2. Identification of the Responsible Testing Location

Name:	Shenzhen Morlab Communications Technology Co., Ltd. Morlab Laboratory
Address:	FL.3, Building A, FeiYang Science Park, No.8 LongChang Road, Block 67, BaoAn District, ShenZhen, GuangDong Province, P. R. China

Annex B Test Setup Photos

Dimensions (L*W*H): 90mm (L) × 90mm (W) × 18mm (H)

Antenna map

The main antenna 1 supports: WCDMA Band II/V, LTE Band 5;

The main antenna 2 supports: LTE Band 7/38/40/41;

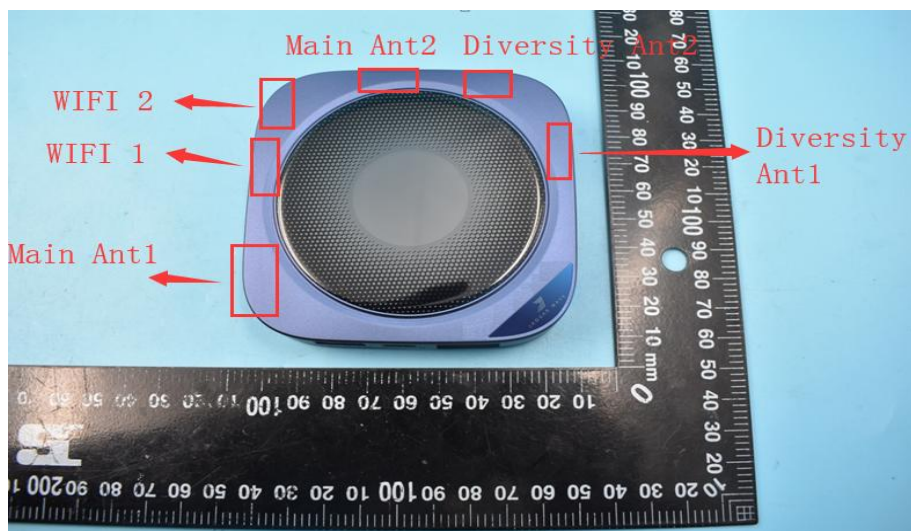
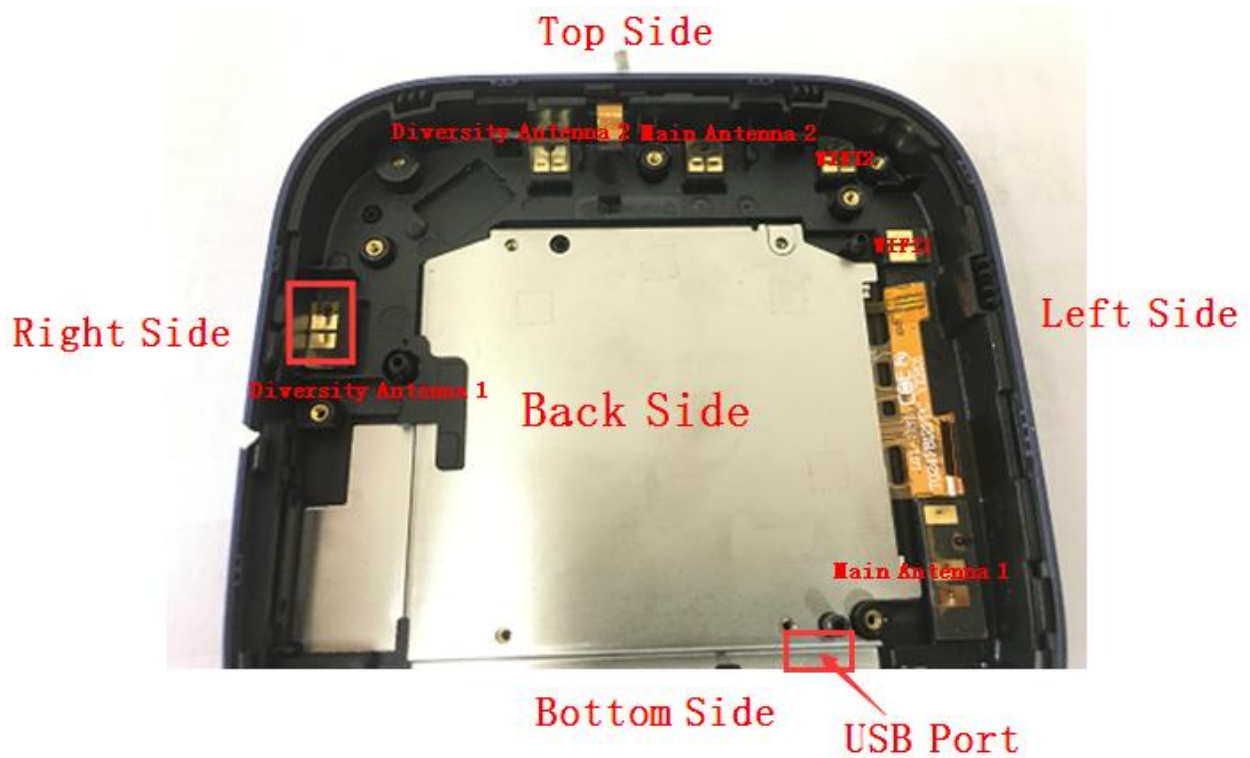

Body

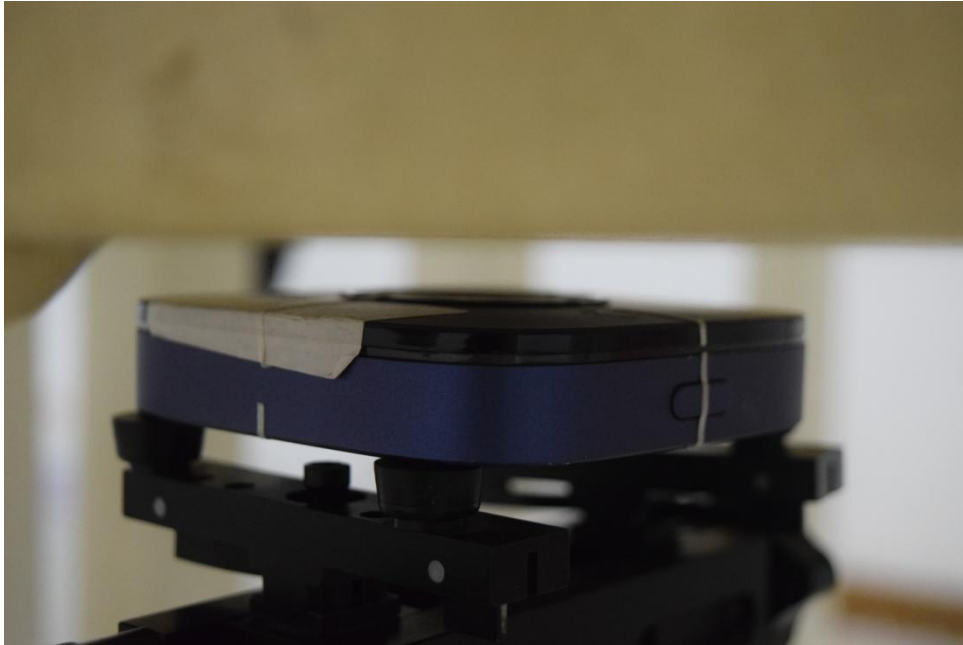

Front Side

(Test distance: 10mm, Thickness of EUT: 18mm)

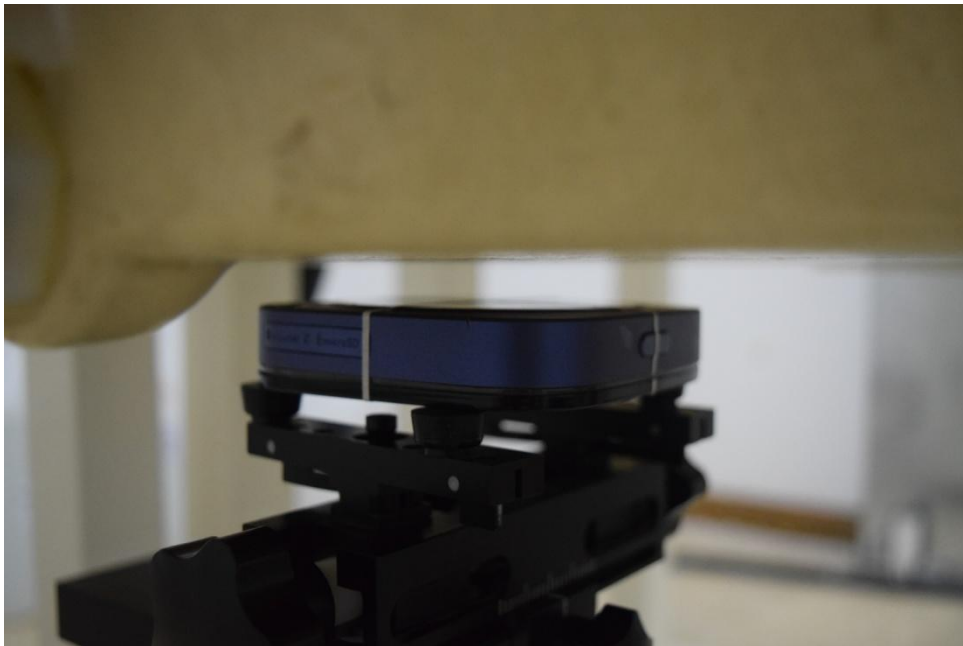

Back Side

(Test distance: 10mm, Thickness of EUT: 18mm)

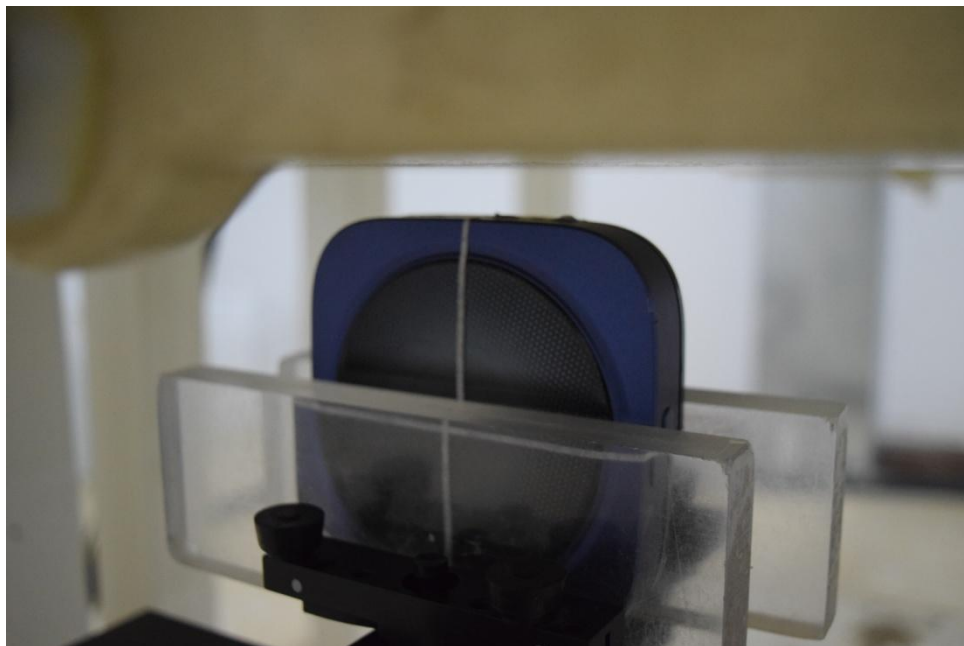

Left Side

(Test distance: 10mm, Thickness of EUT: 18mm)

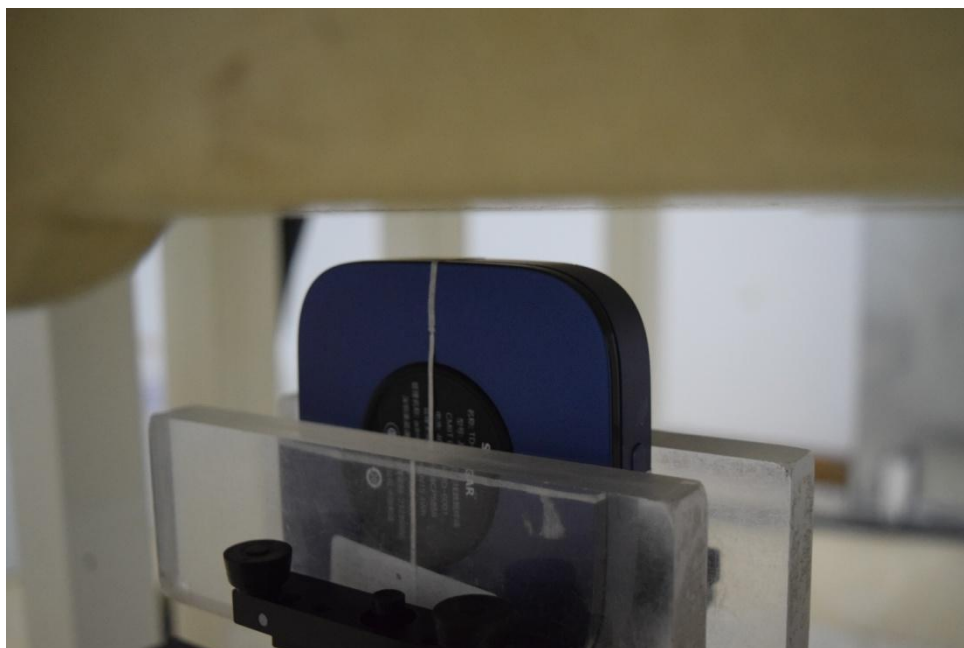

Right Side

(Test distance: 10mm, Thickness of EUT: 18mm)

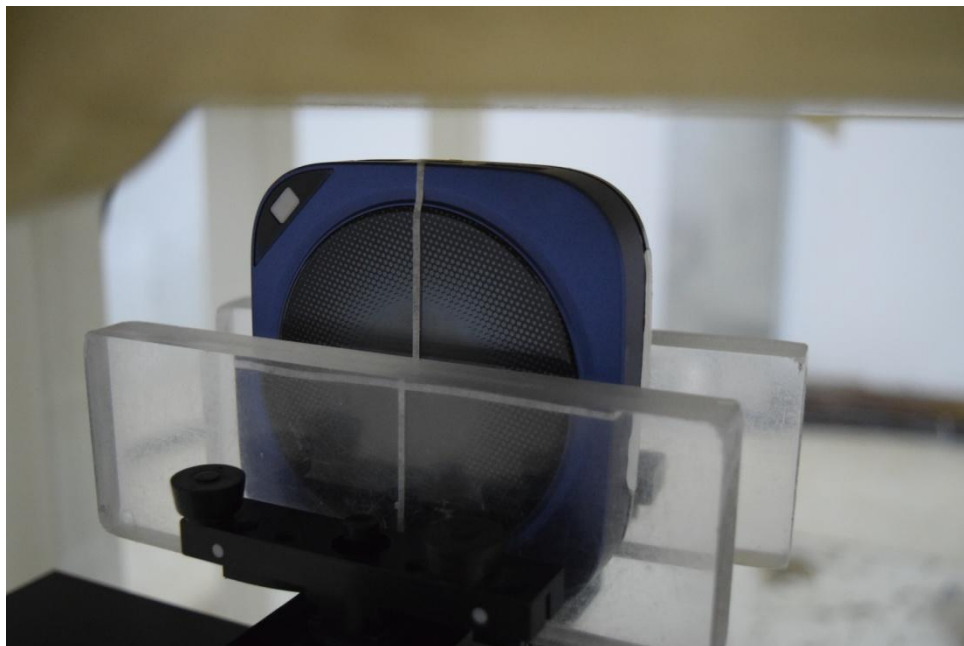

Bottom Side

(Test distance: 10mm, Thickness of EUT: 18mm)

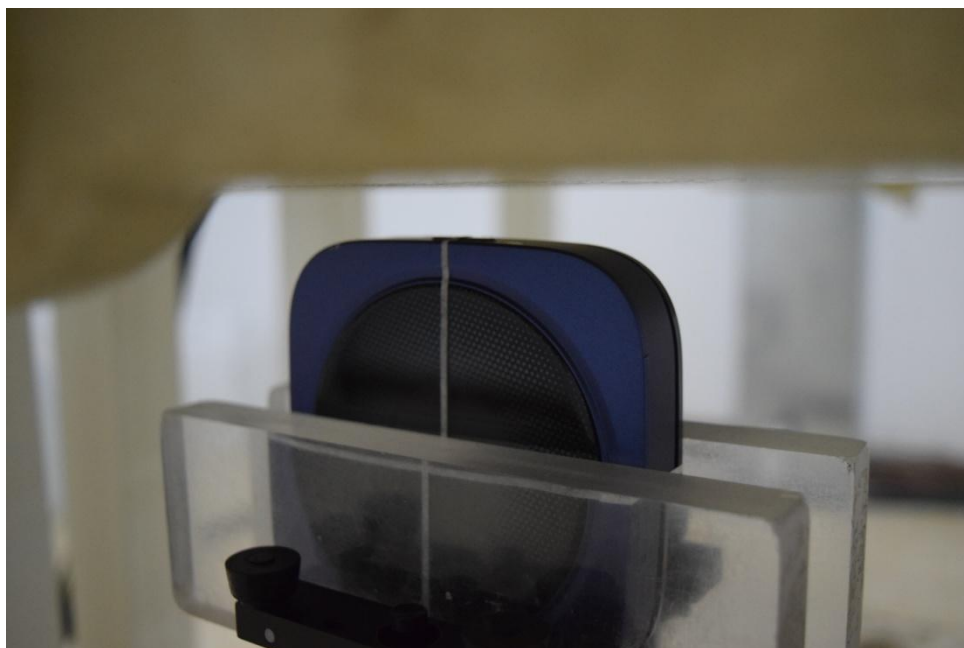

Top Side

(Test distance: 10mm, Thickness of EUT: 18mm)



REPORT No. : SZ19070448S01

Annex C Plots of System Performance Check

System Check_835MHz_Head

Communication System: UID 0, CW (0); Frequency: 835 MHz; Duty Cycle: 1:1

Medium: HSL_835 Medium parameters used: $f = 835 \text{ MHz}$; $\sigma = 0.904 \text{ S/m}$; $\epsilon_r = 41.134$; $\rho = 1000 \text{ kg/m}^3$

Ambient Temperature : $23.2 \text{ }^\circ\text{C}$; Liquid Temperature : $22.2 \text{ }^\circ\text{C}$

DASY5 Configuration:

- Probe: EX3DV4 - SN3823; ConvF(9.32, 9.32, 9.32); Calibrated: 2018.11.12;
- Sensor-Surface: 4mm (Mechanical Surface Detection)
- Electronics: DAE4 Sn480; Calibrated: 2019.04.11
- Phantom: SAM 2; Type: QD000P40CC; Serial: TP:1464
- Measurement SW: DASY52, Version 52.8 (8); SEMCAD X Version 14.6.10 (7331)

CW835/Area Scan (81x81x1): Interpolated grid: $dx=1.500 \text{ mm}$, $dy=1.500 \text{ mm}$

Maximum value of SAR (interpolated) = 2.40 W/kg

CW835/Zoom Scan (5x5x7)/Cube 0: Measurement grid: $dx=8\text{mm}$, $dy=8\text{mm}$, $dz=5\text{mm}$

Reference Value = 53.72 V/m ; Power Drift = -0.04 dB

Peak SAR (extrapolated) = 3.21 W/kg

SAR(1 g) = 2.31 W/kg ; SAR(10 g) = 1.56 W/kg

Maximum value of SAR (measured) = 2.38 W/kg

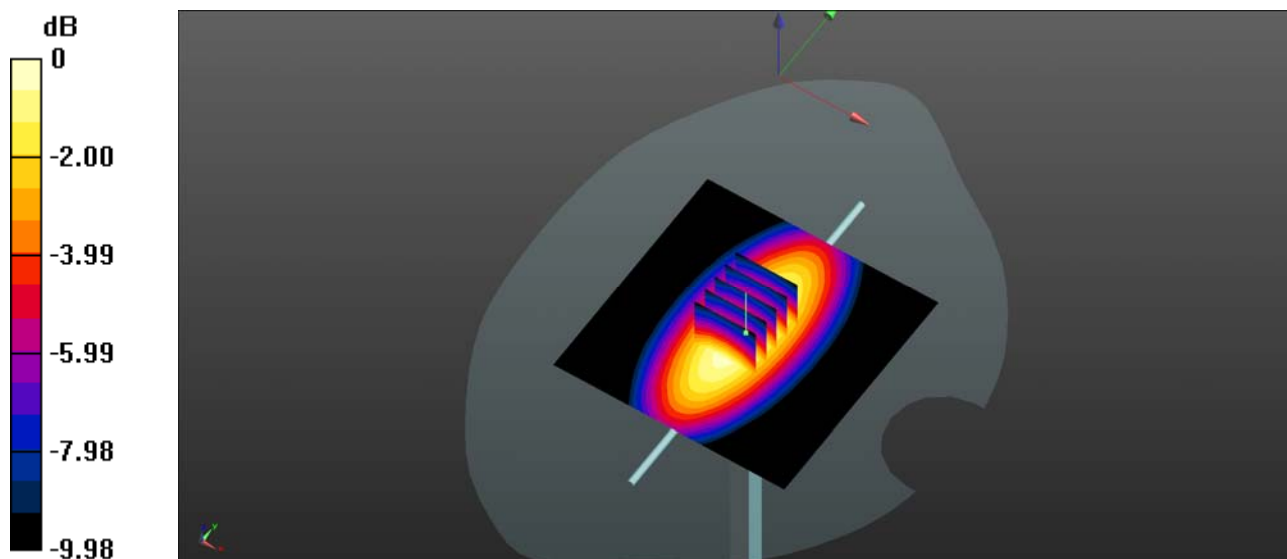

0 dB = 2.40 W/kg

System Check_1900MHz_Head

Communication System: UID 0, CW (0); Frequency: 1900 MHz; Duty Cycle: 1:1

Medium: HSL_1900 Medium parameters used: $f = 1900$ MHz; $\sigma = 1.375$ S/m; $\epsilon_r = 39.998$; $\rho = 1000$ kg/m³

Ambient Temperature : 23.1 °C; Liquid Temperature : 22.6 °C

DASY5 Configuration:

- Probe: EX3DV4 - SN3823; ConvF(7.68, 7.68, 7.68); Calibrated: 2018.11.12;
- Sensor-Surface: 4mm (Mechanical Surface Detection)
- Electronics: DAE4 Sn480; Calibrated: 2019.04.11
- Phantom: SAM 2; Type: QD000P40CC; Serial: TP:1464
- Measurement SW: DASY52, Version 52.8 (8); SEMCAD X Version 14.6.10 (7331)

CW 1900/Area Scan (81x81x1): Interpolated grid: dx=1.500 mm, dy=1.500 mm

Maximum value of SAR (interpolated) = 10.9 W/kg

CW 1900/Zoom Scan (5x5x7)/Cube 0: Measurement grid: dx=8mm, dy=8mm, dz=5mm

Reference Value = 86.62 V/m; Power Drift = 0.17 dB

Peak SAR (extrapolated) = 18.0 W/kg

SAR(1 g) = 9.57 W/kg; SAR(10 g) = 4.94 W/kg

Maximum value of SAR (measured) = 10.7 W/kg

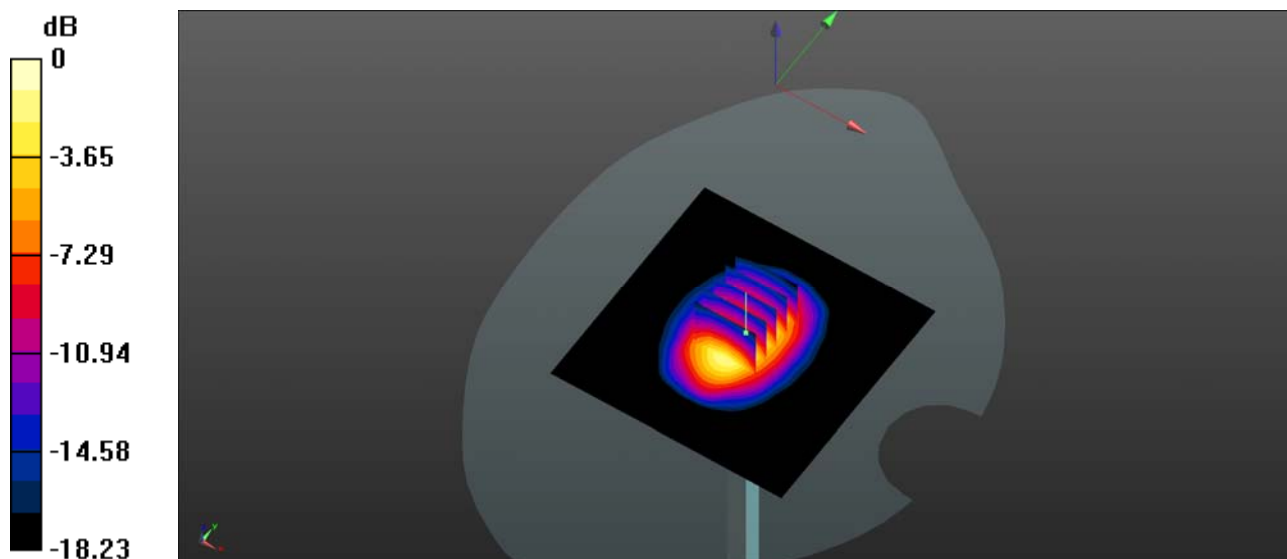

0 dB = 10.9 W/kg

System Check_2300MHz_Head

Communication System: UID 0, CW (0); Frequency: 2300 MHz; Duty Cycle: 1:1

Medium: HSL_2300 Medium parameters used: $f = 2300$ MHz; $\sigma = 1.68$ S/m; $\epsilon_r = 40.616$; $\rho = 1000$ kg/m³

Ambient Temperature : 23.3 °C; Liquid Temperature : 22.3 °C

DASY5 Configuration:

- Probe: EX3DV4 - SN3823; ConvF(7.55, 7.55, 7.55); Calibrated: 2018.11.12;
- Sensor-Surface: 2mm (Mechanical Surface Detection)
- Electronics: DAE4 Sn480; Calibrated: 2019.04.11
- Phantom: SAM 1; Type: QD000P40CC; Serial: TP:1471
- Measurement SW: DASY52, Version 52.8 (8); SEMCAD X Version 14.6.10 (7331)

CW2300/Area Scan (61x61x1): Interpolated grid: dx=1.200 mm, dy=1.200 mm

Maximum value of SAR (interpolated) = 19.2 W/kg

CW2300/Zoom Scan (5x5x7)/Cube 0: Measurement grid: dx=5mm, dy=5mm, dz=5mm

Reference Value = 101.9 V/m; Power Drift = 0.12 dB

Peak SAR (extrapolated) = 26.8 W/kg

SAR(1 g) = 12.5 W/kg; SAR(10 g) = 5.96 W/kg

Maximum value of SAR (measured) = 19.7 W/kg

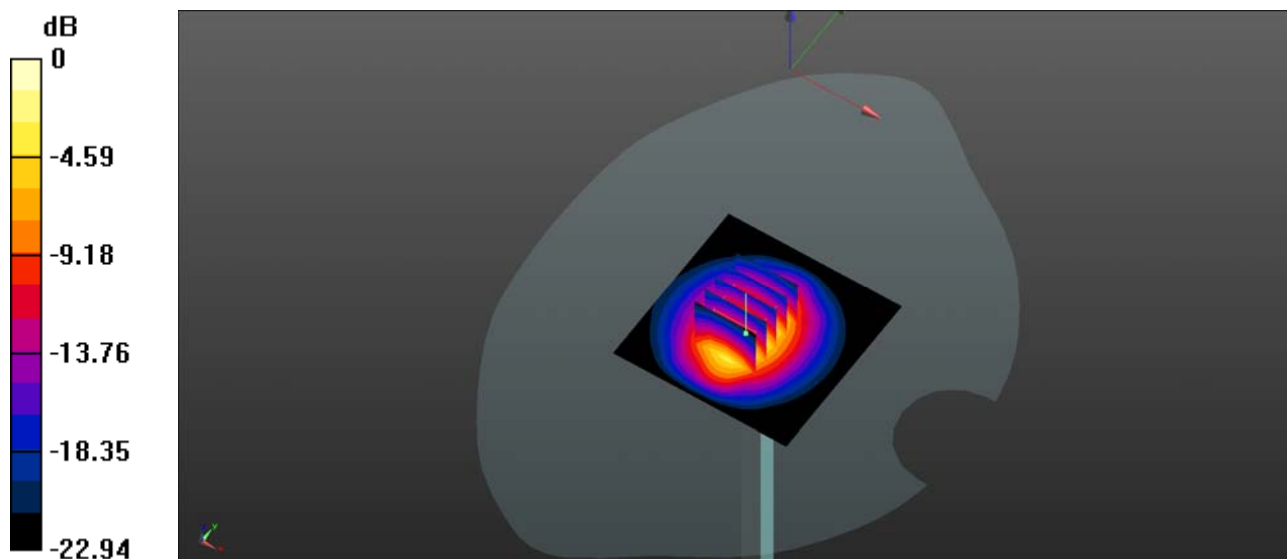

0 dB = 19.2 W/kg

System Check_2450MHz_Head

Communication System: UID 0, CW (0); Frequency: 2450 MHz; Duty Cycle: 1:1

Medium: HSL_2450 Medium parameters used: $f = 2450$ MHz; $\sigma = 1.858$ S/m; $\epsilon_r = 39.975$; $\rho = 1000$ kg/m³

Ambient Temperature : 23.2 °C; Liquid Temperature : 22.3 °C

DASY5 Configuration:

- Probe: EX3DV4 - SN3823; ConvF(7.34, 7.34, 7.34); Calibrated: 2018.11.12;
- Sensor-Surface: 4mm (Mechanical Surface Detection)
- Electronics: DAE4 Sn480; Calibrated: 2019.04.11
- Phantom: SAM 1; Type: QD000P40CC; Serial: TP:1471
- Measurement SW: DASY52, Version 52.8 (8); SEMCAD X Version 14.6.10 (7331)

CW2450/Area Scan (71x81x1): Interpolated grid: dx=1.200 mm, dy=1.200 mm

Maximum value of SAR (interpolated) = 17.0 W/kg

CW2450/Zoom Scan (5x5x7)/Cube 0: Measurement grid: dx=5mm, dy=5mm, dz=5mm

Reference Value = 90.63 V/m; Power Drift = 0.06 dB

Peak SAR (extrapolated) = 28.3 W/kg

SAR(1 g) = 13.3 W/kg; SAR(10 g) = 6.14 W/kg

Maximum value of SAR (measured) = 15.0 W/kg

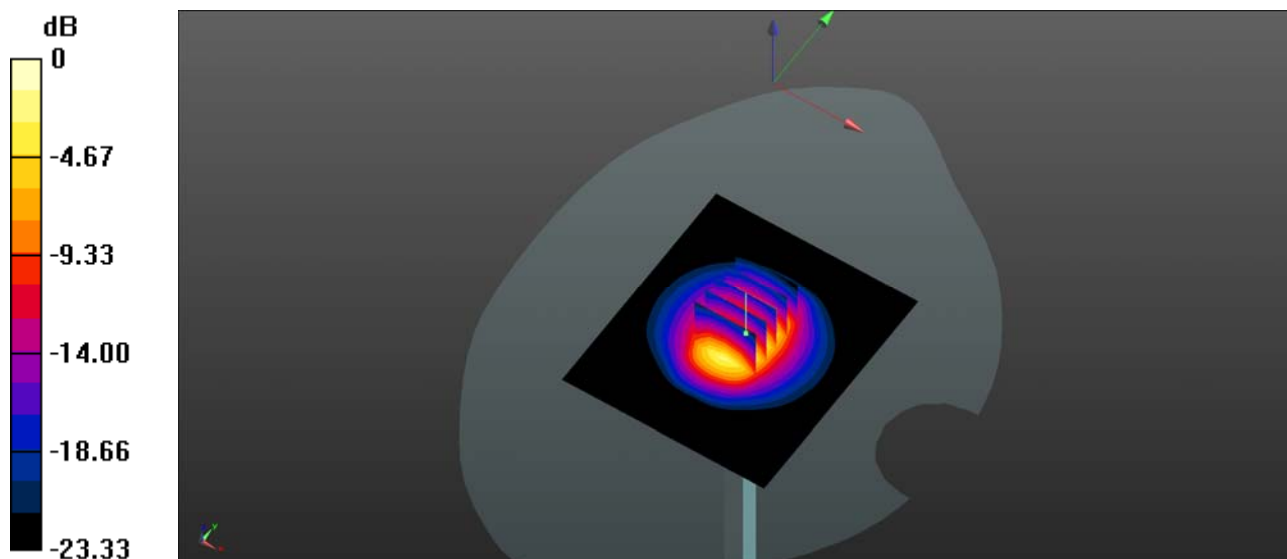

0 dB = 17.0 W/kg

System Check_2600MHz_Head

Communication System: UID 0, CW (0); Frequency: 2600 MHz; Duty Cycle: 1:1

Medium: HSL_2600 Medium parameters used: $f = 2600$ MHz; $\sigma = 2.036$ S/m; $\epsilon_r = 39.303$; $\rho = 1000$ kg/m³

Ambient Temperature : 23.2 °C; Liquid Temperature : 22.1 °C

DASY5 Configuration:

- Probe: EX3DV4 - SN3823; ConvF(6.98, 6.98, 6.98); Calibrated: 2018.11.12;
- Sensor-Surface: 4mm (Mechanical Surface Detection)
- Electronics: DAE4 Sn480; Calibrated: 2019.04.11
- Phantom: SAM 1; Type: QD000P40CC; Serial: TP:1471
- Measurement SW: DASY52, Version 52.8 (8); SEMCAD X Version 14.6.10 (7331)

CW 2600/Area Scan (101x101x1): Interpolated grid: dx=1.200 mm, dy=1.200 mm
 Maximum value of SAR (interpolated) = 17.0 W/kg

CW 2600/Zoom Scan (7x7x7)/Cube 0: Measurement grid: dx=5mm, dy=5mm, dz=5mm

Reference Value = 87.06 V/m; Power Drift = 0.03 dB

Peak SAR (extrapolated) = 32.4 W/kg

SAR(1 g) = 14.3 W/kg; SAR(10 g) = 6.35 W/kg

Maximum value of SAR (measured) = 16.5 W/kg

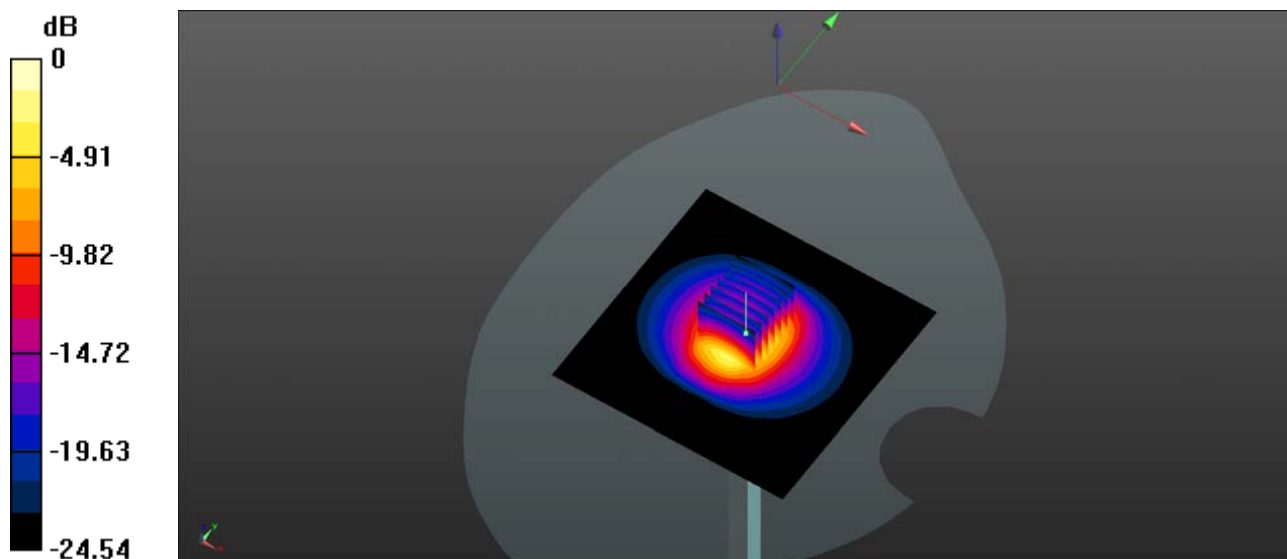

0 dB = 17.0 W/kg

System Check_5250MHz_Head

Communication System: UID 0, CW (0); Frequency: 5250 MHz; Duty Cycle: 1:1

Medium: HSL_5250 Medium parameters used: $f = 5250$ MHz; $\sigma = 4.757$ S/m; $\epsilon_r = 36.931$; $\rho = 1000$ kg/m³

Ambient Temperature : 23.2 °C; Liquid Temperature : 22.8 °C

DASY5 Configuration:

- Probe: EX3DV4 - SN3823; ConvF(5.28, 5.28, 5.28); Calibrated: 2018.11.12;
- Sensor-Surface: 2mm (Mechanical Surface Detection)
- Electronics: DAE4 Sn480; Calibrated: 2019.04.11
- Phantom: SAM 2; Type: QD000P40CC; Serial: TP:1464
- Measurement SW: DASY52, Version 52.8 (8); SEMCAD X Version 14.6.10 (7331)

CW 5250/Area Scan (201x201x1): Interpolated grid: dx=1.000 mm, dy=1.000 mm
Maximum value of SAR (interpolated) = 8.71 W/kg

CW 5250/Zoom Scan (7x7x7)/Cube 0: Measurement grid: dx=4mm, dy=4mm, dz=2mm

Reference Value = 35.32 V/m; Power Drift = 0.04 dB

Peak SAR (extrapolated) = 46.6 W/kg

SAR(1 g) = 8.05 W/kg; SAR(10 g) = 2.29 W/kg

Maximum value of SAR (measured) = 8.31 W/kg

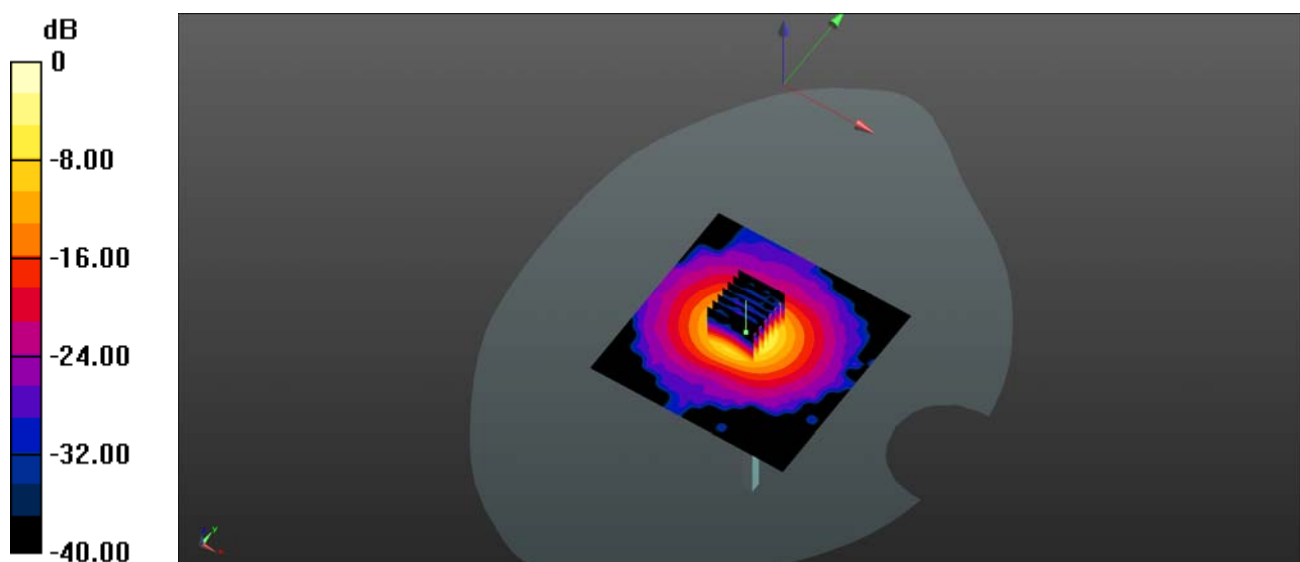

0 dB = 8.71 W/kg

System Check_5750MHz_Head

Communication System: UID 0, CW (0); Frequency: 5750 MHz; Duty Cycle: 1:1

Medium: HSL_5750 Medium parameters used: $f = 5750$ MHz; $\sigma = 5.374$ S/m; $\epsilon_r = 35.896$; $\rho = 1000$ kg/m³

Ambient Temperature : 23.2 °C; Liquid Temperature : 22.8 °C

DASY5 Configuration:

- Probe: EX3DV4 - SN3823; ConvF(4.6, 4.6, 4.6); Calibrated: 2018.11.12;
- Sensor-Surface: 2mm (Mechanical Surface Detection)
- Electronics: DAE4 Sn480; Calibrated: 2019.04.11
- Phantom: SAM 2; Type: QD000P40CC; Serial: TP:1464
- Measurement SW: DASY52, Version 52.8 (8); SEMCAD X Version 14.6.10 (7331)

CW 5750/Area Scan (101x101x1): Interpolated grid: dx=1.000 mm, dy=1.000 mm
Maximum value of SAR (interpolated) = 16.8 W/kg

CW 5750/Zoom Scan (7x7x13)/Cube 0: Measurement grid: dx=4mm, dy=4mm, dz=2mm

Reference Value = 37.69 V/m; Power Drift = 0.10 dB

Peak SAR (extrapolated) = 41.8 W/kg

SAR(1 g) = 7.87 W/kg; SAR(10 g) = 2.23 W/kg

Maximum value of SAR (measured) = 16.8 W/kg

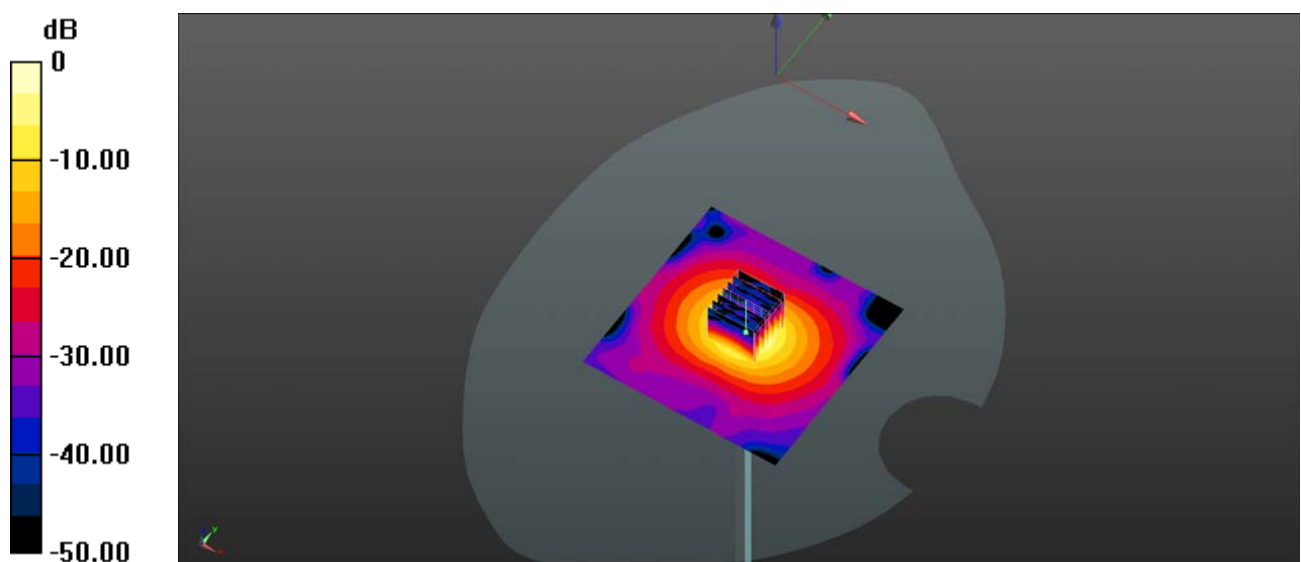

0 dB = 16.8 W/kg

System Check_835MHz_Body

Communication System: UID 0, CW (0); Frequency: 835 MHz; Duty Cycle: 1:1
 Medium: MSL_835 Medium parameters used: $f = 835 \text{ MHz}$; $\sigma = 0.981 \text{ S/m}$; $\epsilon_r = 55.747$; $\rho = 1000 \text{ kg/m}^3$
 Ambient Temperature : $23.2 \text{ }^\circ\text{C}$; Liquid Temperature : $22.3 \text{ }^\circ\text{C}$

DASY5 Configuration:

- Probe: EX3DV4 - SN3823; ConvF(9.24, 9.24, 9.24); Calibrated: 2018.11.12;
- Sensor-Surface: 4mm (Mechanical Surface Detection)
- Electronics: DAE4 Sn480; Calibrated: 2019.04.11
- Phantom: SAM 1; Type: QD000P40CC; Serial: TP:1471
- Measurement SW: DASY52, Version 52.8 (8); SEMCAD X Version 14.6.10 (7331)

CW 835/Area Scan (81x81x1): Interpolated grid: $dx=1.500 \text{ mm}$, $dy=1.500 \text{ mm}$
 Maximum value of SAR (interpolated) = 2.65 W/kg

CW 835/Zoom Scan (5x5x7)/Cube 0: Measurement grid: $dx=8\text{mm}$, $dy=8\text{mm}$, $dz=5\text{mm}$
 Reference Value = 51.05 V/m ; Power Drift = 0.04 dB
 Peak SAR (extrapolated) = 3.56 W/kg
SAR(1 g) = 2.46 W/kg ; SAR(10 g) = 1.65 W/kg
 Maximum value of SAR (measured) = 2.65 W/kg

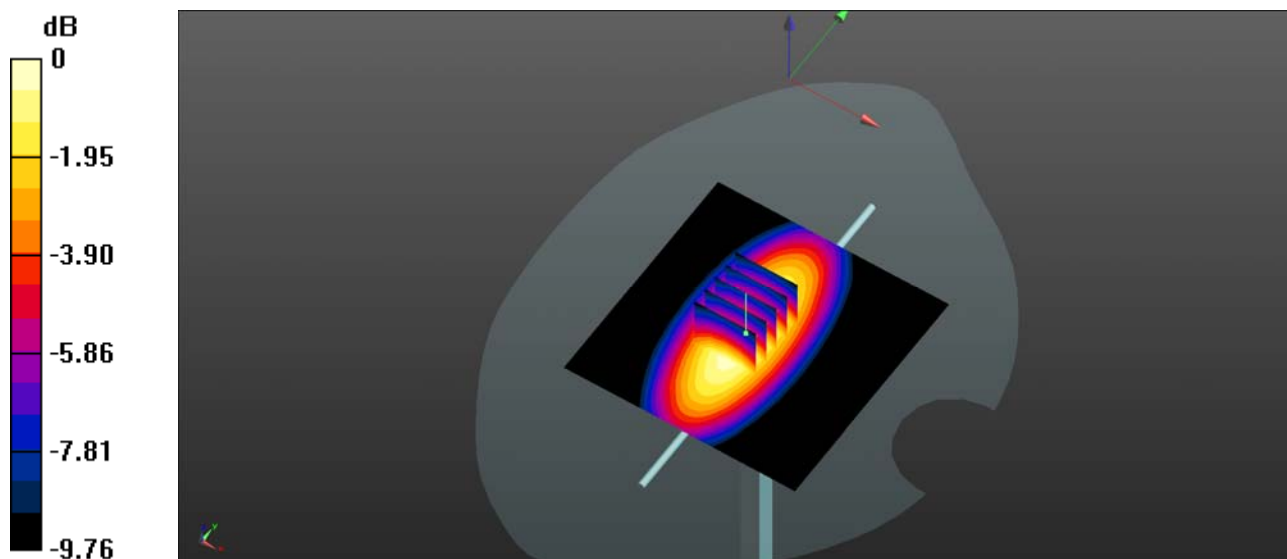

0 dB = 2.65 W/kg

System Check_1900MHz_Body

Communication System: UID 0, CW (0); Frequency: 1900 MHz; Duty Cycle: 1:1
 Medium: MSL_1900 Medium parameters used: $f = 1900$ MHz; $\sigma = 1.519$ S/m; $\epsilon_r = 54.557$; $\rho = 1000$ kg/m³
 Ambient Temperature : 23.5 °C; Liquid Temperature : 22.7 °C

DASY5 Configuration:

- Probe: EX3DV4 - SN3823; ConvF(7.4, 7.4, 7.4); Calibrated: 2018.11.12;
- Sensor-Surface: 4mm (Mechanical Surface Detection)
- Electronics: DAE4 Sn480; Calibrated: 2019.04.11
- Phantom: SAM 2; Type: QD000P40CC; Serial: TP:1464
- Measurement SW: DASY52, Version 52.8 (8); SEMCAD X Version 14.6.10 (7331)

CW 1900/Area Scan (81x81x1): Interpolated grid: dx=1.500 mm, dy=1.500 mm
 Maximum value of SAR (interpolated) = 11.0 W/kg

CW 1900/Zoom Scan (5x5x7)/Cube 0: Measurement grid: dx=8mm, dy=8mm, dz=5mm
 Reference Value = 79.21 V/m; Power Drift = 0.09 dB
 Peak SAR (extrapolated) = 17.8 W/kg
SAR(1 g) = 9.94 W/kg; SAR(10 g) = 5.16 W/kg
 Maximum value of SAR (measured) = 11.2 W/kg

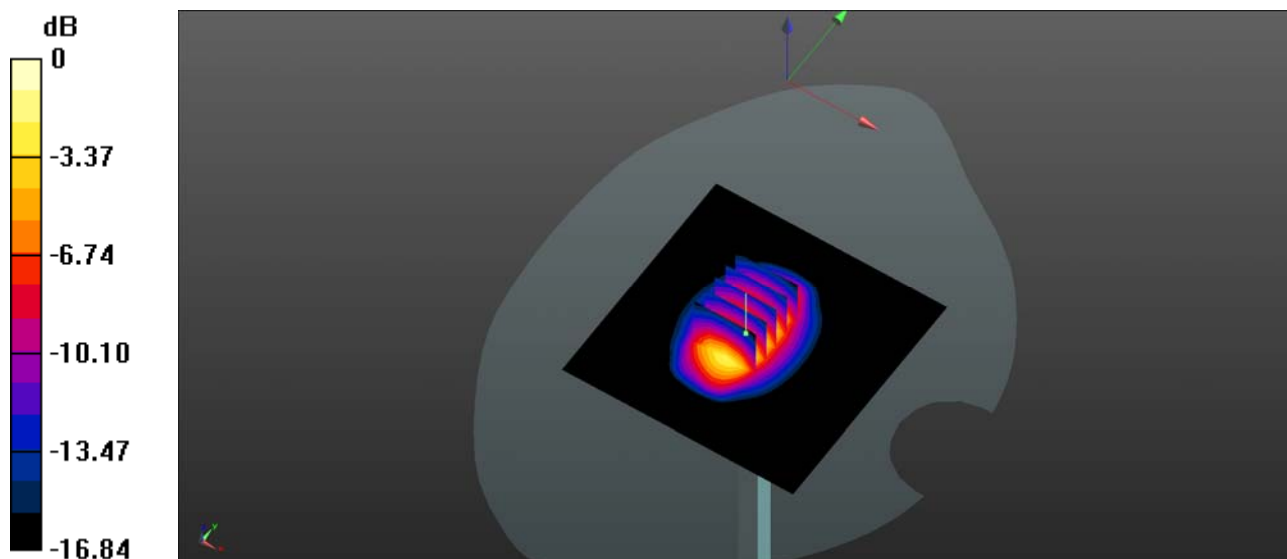

0 dB = 11.0 W/kg

System Check_2300MHz_Body

Communication System: UID 0, CW (0); Frequency: 2300 MHz; Duty Cycle: 1:1
Medium: MSL_2300 Medium parameters used: $f = 2300$ MHz; $\sigma = 1.858$ S/m; $\epsilon_r = 51.484$; $\rho = 1000$ kg/m³
Ambient Temperature : 23.1 °C; Liquid Temperature : 22.3 °C

DASY5 Configuration:

- Probe: EX3DV4 - SN3823; ConvF(7.55, 7.55, 7.55); Calibrated: 2018.11.12;
- Sensor-Surface: 4mm (Mechanical Surface Detection)
- Electronics: DAE4 Sn480; Calibrated: 2019.04.11
- Phantom: SAM 1; Type: QD000P40CC; Serial: TP:1471
- Measurement SW: DASY52, Version 52.8 (8); SEMCAD X Version 14.6.10 (7331)

CW 2300/Area Scan (101x101x1): Interpolated grid: dx=1.200 mm, dy=1.200 mm
Maximum value of SAR (interpolated) = 13.7 W/kg

CW 2300/Zoom Scan (7x7x7)/Cube 0: Measurement grid: dx=5mm, dy=5mm, dz=5mm
Reference Value = 85.48 V/m; Power Drift = 0.10 dB
Peak SAR (extrapolated) = 25.2 W/kg
SAR(1 g) = 12.13 W/kg; SAR(10 g) = 6.02 W/kg
Maximum value of SAR (measured) = 13.7 W/kg

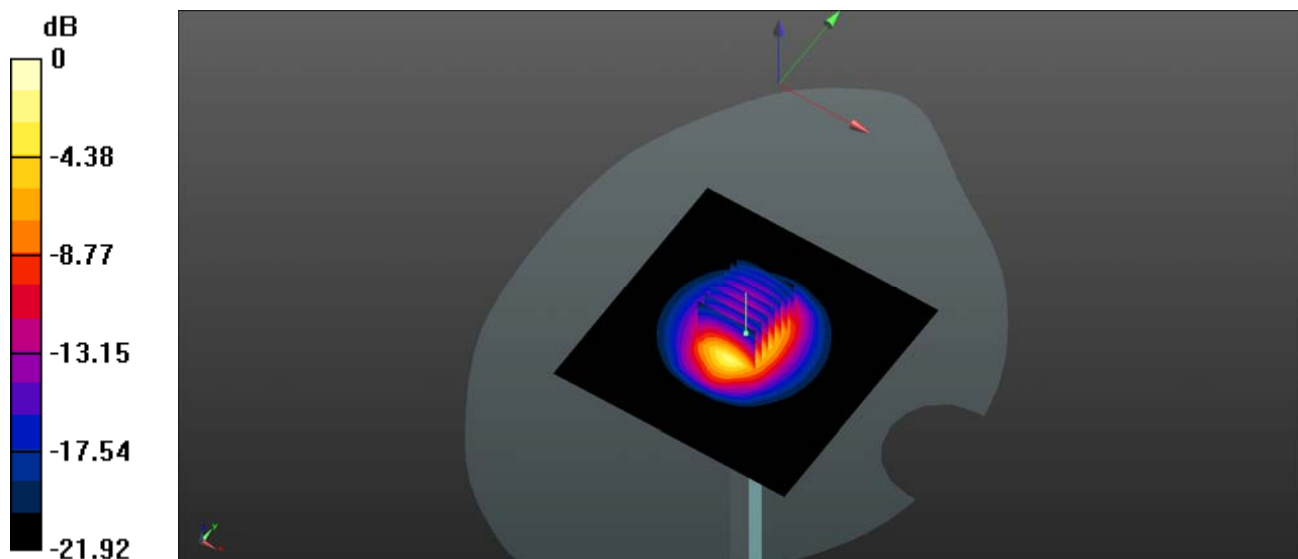

0 dB = 13.7 W/kg

System Check_2450MHz_Body

Communication System: UID 0, CW (0); Frequency: 2450 MHz; Duty Cycle: 1:1

Medium: MSL_2450 Medium parameters used: $f = 2450$ MHz; $\sigma = 1.897$ S/m; $\epsilon_r = 53.47$; $\rho = 1000$ kg/m³

Ambient Temperature : 23.2 °C; Liquid Temperature : 22.4 °C

DASY5 Configuration:

- Probe: EX3DV4 - SN3823; ConvF(7.15, 7.15, 7.15); Calibrated: 2018.11.12;
- Sensor-Surface: 4mm (Mechanical Surface Detection)
- Electronics: DAE4 Sn480; Calibrated: 2019.04.11
- Phantom: SAM 1; Type: QD000P40CC; Serial: TP:1471
- Measurement SW: DASY52, Version 52.8 (8); SEMCAD X Version 14.6.10 (7331)

CW 2450/Area Scan (101x101x1): Interpolated grid: dx=1.200 mm, dy=1.200 mm
 Maximum value of SAR (interpolated) = 14.3 W/kg

CW 2450/Zoom Scan (7x7x7)/Cube 0: Measurement grid: dx=5mm, dy=5mm, dz=5mm
 Reference Value = 87.03 V/m; Power Drift = 0.02 dB
 Peak SAR (extrapolated) = 24.5 W/kg
SAR(1 g) = 12.7 W/kg; SAR(10 g) = 5.74 W/kg
 Maximum value of SAR (measured) = 14.2 W/kg

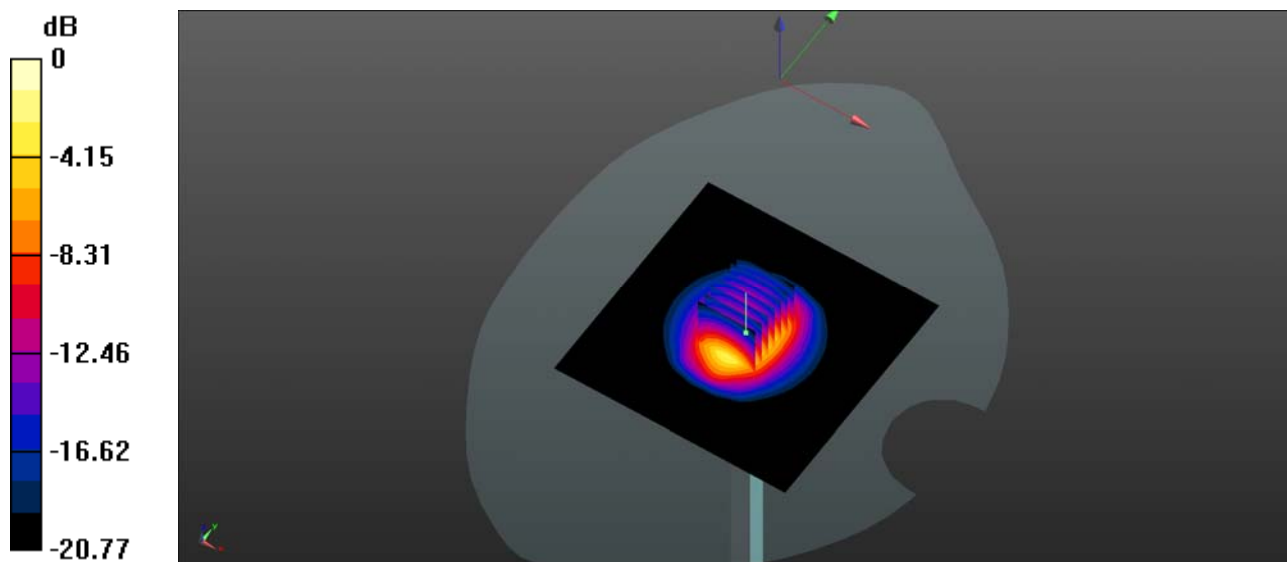

0 dB = 14.3 W/kg

System Check_2600MHz_Body_190425

Communication System: UID 0, CW (0); Frequency: 2600 MHz; Duty Cycle: 1:1

Medium: MSL_2600 Medium parameters used: $f = 2600$ MHz; $\sigma = 2.08$ S/m; $\epsilon_r = 52.502$; $\rho = 1000$ kg/m³

Ambient Temperature : 23.4 °C; Liquid Temperature : 22.4 °C

DASY5 Configuration:

- Probe: EX3DV4 - SN3823; ConvF(6.98, 6.98, 6.98); Calibrated: 2018.11.12;
- Sensor-Surface: 4mm (Mechanical Surface Detection)
- Electronics: DAE4 Sn480; Calibrated: 2019.04.11
- Phantom: SAM 2; Type: QD000P40CC; Serial: TP:1464
- Measurement SW: DASY52, Version 52.8 (8); SEMCAD X Version 14.6.10 (7331)

CW 2600/Area Scan (101x101x1): Interpolated grid: dx=1.200 mm, dy=1.200 mm

Maximum value of SAR (interpolated) = 14.2 W/kg

CW 2600/Zoom Scan (7x7x7)/Cube 0: Measurement grid: dx=5mm, dy=5mm, dz=5mm

Reference Value = 82.94 V/m; Power Drift = -0.01 dB

Peak SAR (extrapolated) = 26.2 W/kg

SAR(1 g) = 13.4 W/kg; SAR(10 g) = 6.26 W/kg

Maximum value of SAR (measured) = 14.1 W/kg

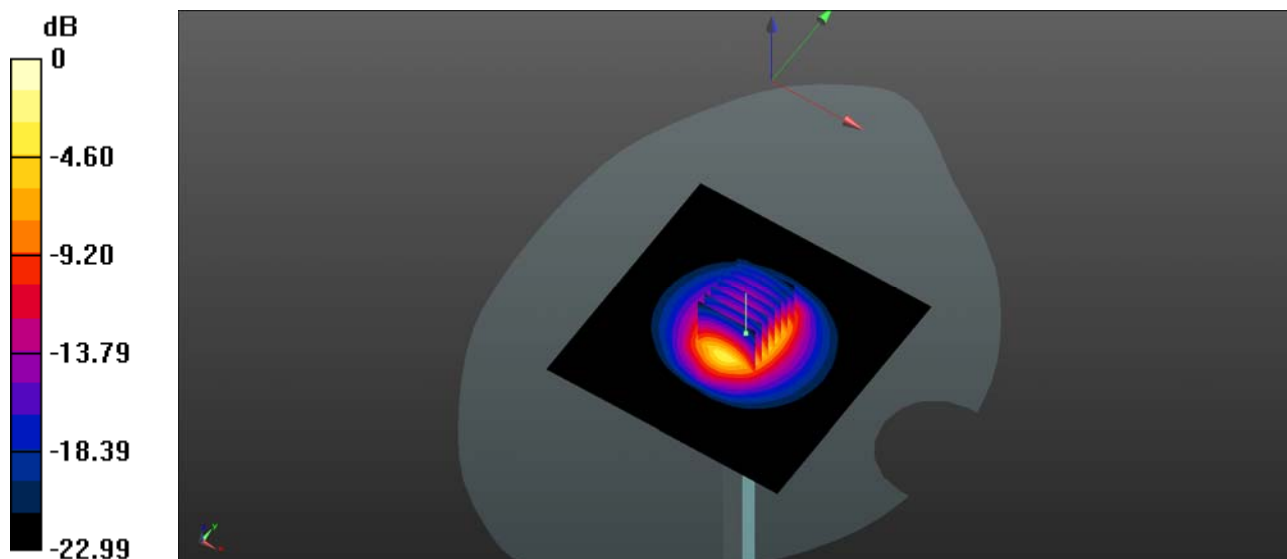

0 dB = 14.2 W/kg

System Check_5250MHz_Body

Communication System: UID 0, CW (0); Frequency: 5250 MHz; Duty Cycle: 1:1

Medium: MSL_5250 Medium parameters used: $f = 5250$ MHz; $\sigma = 5.42$ S/m; $\epsilon_r = 48.367$; $\rho = 1000$ kg/m³

Ambient Temperature : 23.2 °C; Liquid Temperature : 22.2 °C

DASY5 Configuration:

- Probe: EX3DV4 - SN3823; ConvF(4.73, 4.73, 4.73); Calibrated: 2018.11.12;
- Sensor-Surface: 2mm (Mechanical Surface Detection)
- Electronics: DAE4 Sn480; Calibrated: 2019.04.11
- Phantom: SAM 1; Type: QD000P40CC; Serial: TP:1471
- Measurement SW: DASY52, Version 52.8 (8); SEMCAD X Version 14.6.10 (7331)

CW 5250/Area Scan (201x201x1): Interpolated grid: dx=1.000 mm, dy=1.000 mm

Maximum value of SAR (interpolated) = 11.0 W/kg

CW 5250/Zoom Scan (7x7x7)/Cube 0: Measurement grid: dx=4mm, dy=4mm, dz=4mm

Reference Value = 37.26 V/m; Power Drift = 0.04 dB

Peak SAR (extrapolated) = 58.8 W/kg

SAR(1 g) = 7.6 W/kg; SAR(10 g) = 2.1 W/kg

Maximum value of SAR (measured) = 10.6 W/kg

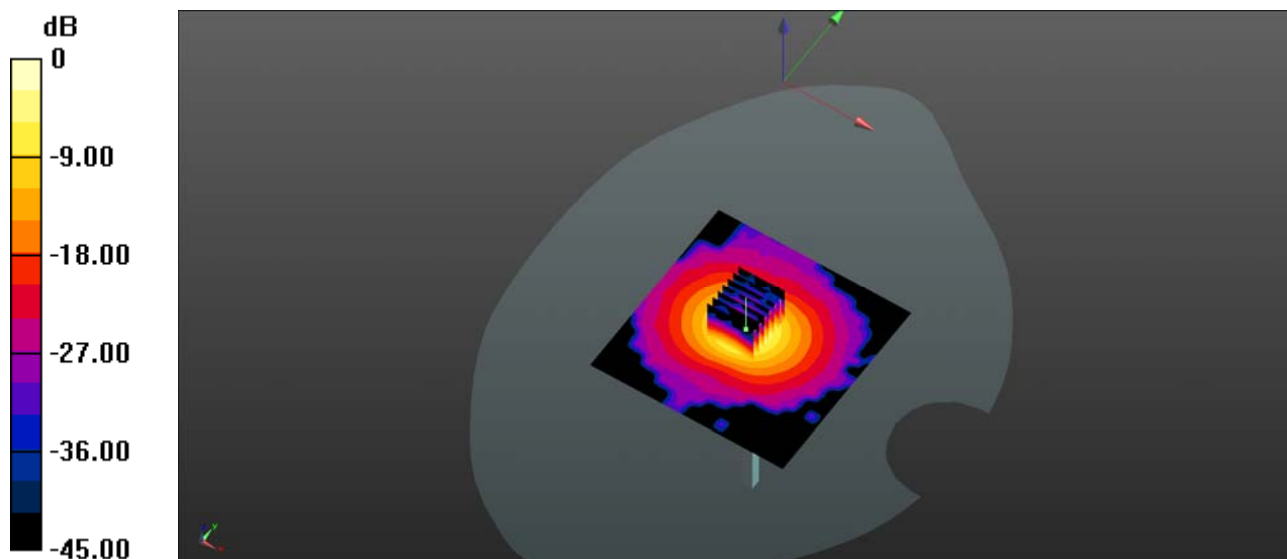

0 dB = 11.0 W/kg = 10.41 dBW/kg

System Check_5750MHz_Body

Communication System: UID 0, CW (0); Frequency: 5750 MHz; Duty Cycle: 1:1

Medium: HSL_5750 Medium parameters used: $f = 5750$ MHz; $\sigma = 6.06$ S/m; $\epsilon_r = 47.472$; $\rho = 1000$ kg/m³

Ambient Temperature : 23.2 °C; Liquid Temperature : 22.2 °C

DASY5 Configuration:

- Probe: EX3DV4 - SN3823; ConvF(3.98, 3.98, 3.98); Calibrated: 2018.11.12;
- Sensor-Surface: 2mm (Mechanical Surface Detection)
- Electronics: DAE4 Sn480; Calibrated: 2019.04.11
- Phantom: SAM 1; Type: QD000P40CC; Serial: TP:1471
- Measurement SW: DASY52, Version 52.8 (8); SEMCAD X Version 14.6.10 (7331)

CW 5750/Area Scan (101x101x1): Interpolated grid: dx=1.000 mm, dy=1.000 mm
Maximum value of SAR (interpolated) = 10.8 W/kg

CW 5750/Zoom Scan (7x7x13)/Cube 0: Measurement grid: dx=4mm, dy=4mm, dz=2mm

Reference Value = 37.15 V/m; Power Drift = 0.12 dB

Peak SAR (extrapolated) = 47.2 W/kg

SAR(1 g) = 7.77 W/kg; SAR(10 g) = 2.15 W/kg

Maximum value of SAR (measured) = 10.8 W/kg

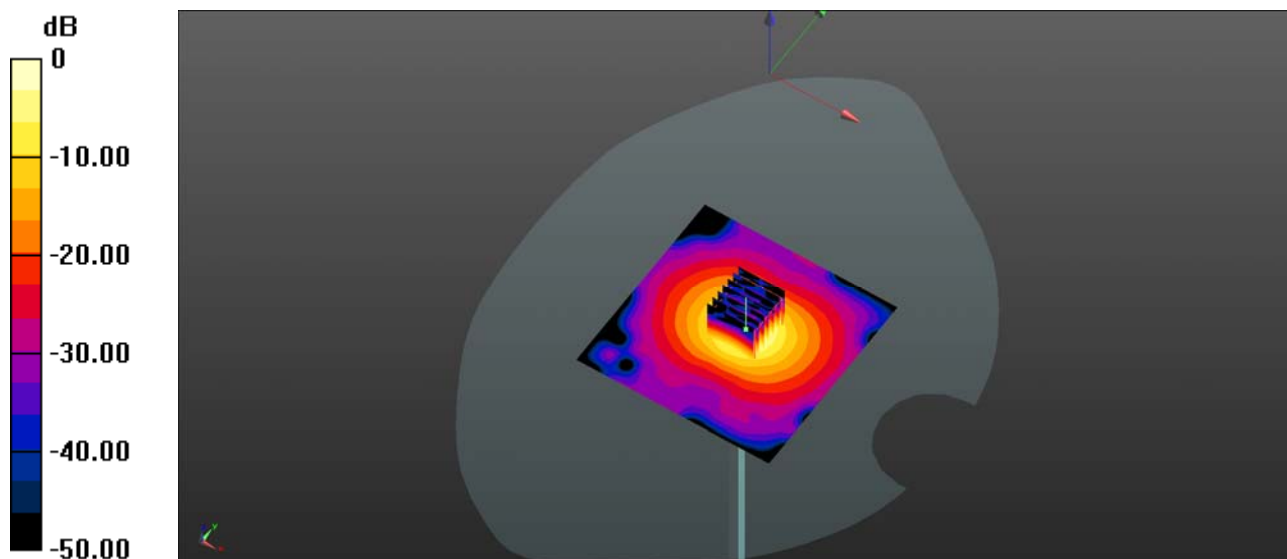

0 dB = 10.8 W/kg



REPORT No. : SZ19070448S01

Annex D Plots of Maximum SAR Test Results

WCDMA Band II_RMC 12.2Kbps_Front Side_10mm_Ch9400

Communication System: UID 0, UMTS-FDD (0); Frequency: 1880 MHz; Duty Cycle: 1:1
 Medium: HSL_1900 Medium parameters used: $f = 1880$ MHz; $\sigma = 1.366$ S/m; $\epsilon_r = 40.167$; $\rho = 1000$ kg/m³
 Ambient Temperature : 23.1 °C; Liquid Temperature : 22.6 °C

DASY5 Configuration:

- Probe: EX3DV4 - SN3823; ConvF(7.68, 7.68, 7.68); Calibrated: 2018.11.12;
- Sensor-Surface: 4mm (Mechanical Surface Detection)
- Electronics: DAE4 Sn480; Calibrated: 2019.04.11
- Phantom: SAM 2; Type: QD000P40CC; Serial: TP:1464
- Measurement SW: DASY52, Version 52.8 (8); SEMCAD X Version 14.6.10 (7331)

Ch9400/Area Scan (111x111x1): Interpolated grid: dx=1.500 mm, dy=1.500 mm
 Maximum value of SAR (interpolated) = 0.723 W/kg

Ch9400/Zoom Scan (7x7x7)/Cube 0: Measurement grid: dx=8mm, dy=8mm, dz=5mm
 Reference Value = 5.816 V/m; Power Drift = 0.04 dB
 Peak SAR (extrapolated) = 1.52 W/kg
SAR(1 g) = 0.622 W/kg; SAR(10 g) = 0.311 W/kg
 Maximum value of SAR (measured) = 0.721 W/kg

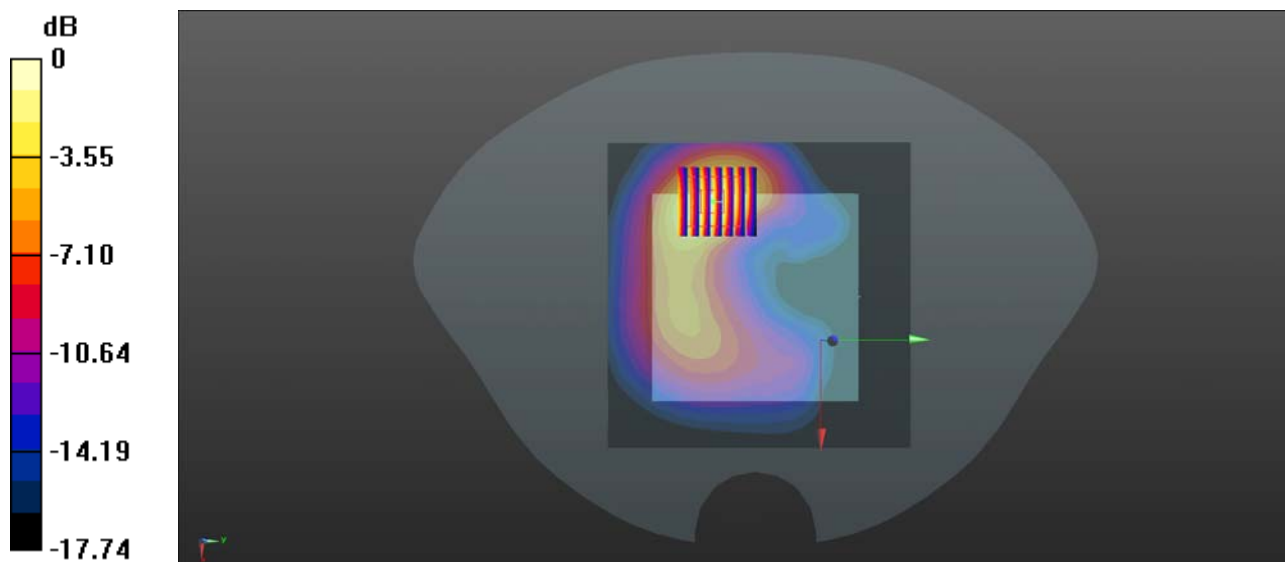

0 dB = 0.723 W/kg

WCDMA Band V_RMC 12.2Kbps_Front Side_10mm_Ch4183

Communication System: UID 0, UMTS-FDD (0); Frequency: 836.6 MHz; Duty Cycle: 1:1
Medium: HSL_835 Medium parameters used: $f = 837$ MHz; $\sigma = 0.923$ S/m; $\epsilon_r = 43.415$; $\rho = 1000$ kg/m³

Ambient Temperature : 23.2 °C; Liquid Temperature : 22.2 °C

DASY5 Configuration:

- Probe: EX3DV4 - SN3823; ConvF(9.32, 9.32, 9.32); Calibrated: 2018.11.12;
- Sensor-Surface: 4mm (Mechanical Surface Detection)
- Electronics: DAE4 Sn480; Calibrated: 2019.04.11
- Phantom: SAM 2; Type: QD000P40CC; Serial: TP:1464
- Measurement SW: DASY52, Version 52.8 (8); SEMCAD X Version 14.6.10 (7331)

Ch4183/Area Scan (71x61x1): Interpolated grid: dx=1.5000 mm, dy=1.5000 mm
Maximum value of SAR (interpolated) = 0.633 W/kg

Ch4183/Zoom Scan (5x5x7)/Cube 0: Measurement grid: dx=8mm, dy=8mm, dz=5mm
Reference Value = 23.78 V/m; Power Drift = -0.06 dB
Peak SAR (extrapolated) = 0.903 W/kg
SAR(1 g) = 0.602 W/kg; SAR(10 g) = 0.396 W/kg
Maximum value of SAR (measured) = 0.674 W/kg

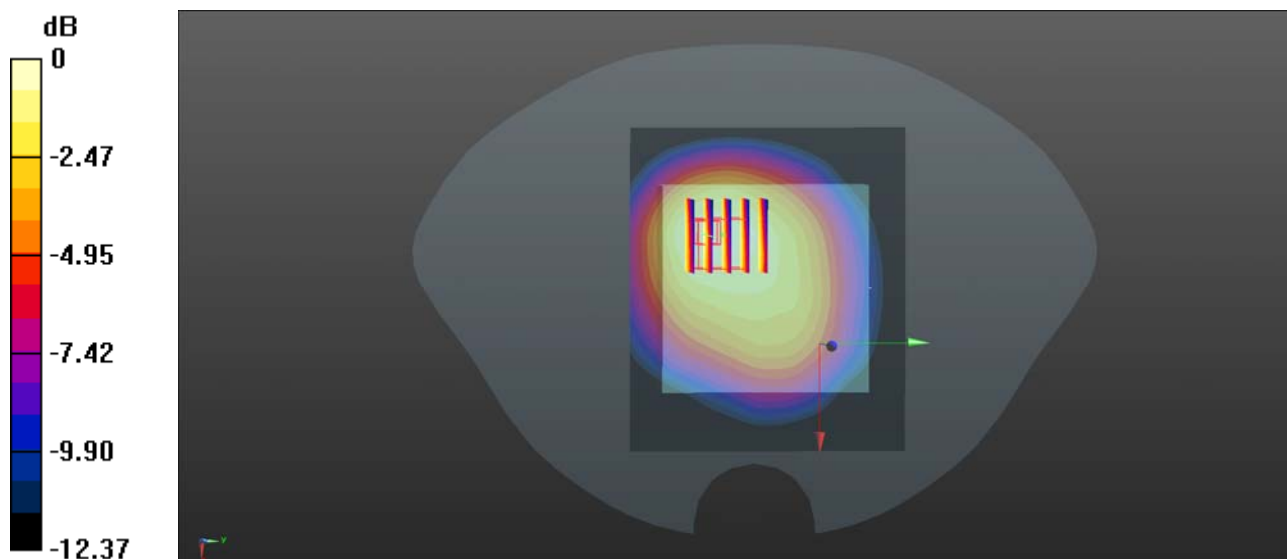

0 dB = 0.633 W/kg

LTE Band 5_10MHz_QPSK_1RB_0Offset_Front Side_10mm_Ch20525

Communication System: UID 0, UMTS-FDD (0); Frequency: 836.6 MHz; Duty Cycle: 1:1
 Medium: HSL_835 Medium parameters used: $f = 837 \text{ MHz}$; $\sigma = 0.923 \text{ S/m}$; $\epsilon_r = 43.415$; $\rho = 1000 \text{ kg/m}^3$

Ambient Temperature : 23.2 °C; Liquid Temperature : 22.2 °C

DASY5 Configuration:

- Probe: EX3DV4 - SN3823; ConvF(9.32, 9.32, 9.32); Calibrated: 2018.11.12;
- Sensor-Surface: 4mm (Mechanical Surface Detection)
- Electronics: DAE4 Sn480; Calibrated: 2019.04.11
- Phantom: SAM 2; Type: QD000P40CC; Serial: TP:1464
- Measurement SW: DASY52, Version 52.8 (8); SEMCAD X Version 14.6.10 (7331)

Ch20525/Area Scan (71x61x1): Interpolated grid: $dx=1.5000 \text{ mm}$, $dy=1.5000 \text{ mm}$
 Maximum value of SAR (interpolated) = 0.717 W/kg

Ch20525/Zoom Scan (5x5x7)/Cube 0: Measurement grid: $dx=8\text{mm}$, $dy=8\text{mm}$, $dz=5\text{mm}$
 Reference Value = 19.21 V/m; Power Drift = 0.02 dB
 Peak SAR (extrapolated) = 0.985 W/kg
SAR(1 g) = 0.665 W/kg; SAR(10 g) = 0.446 W/kg
 Maximum value of SAR (measured) = 0.710 W/kg

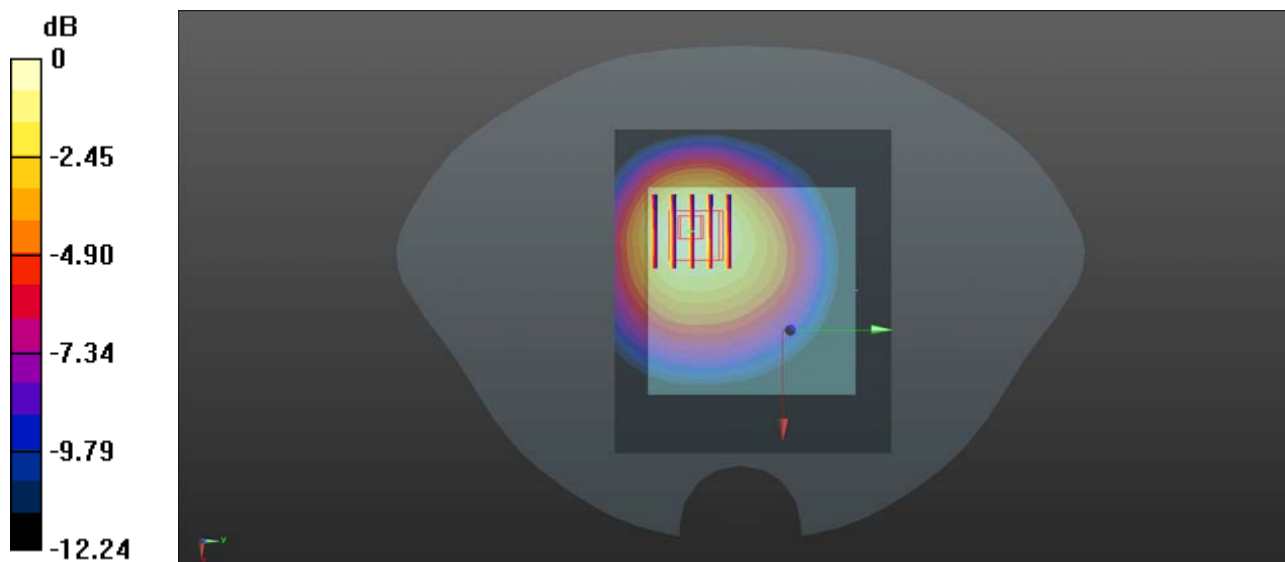

0 dB = 0.717 W/kg

LTE Band 7_20MHz_QPSK_1RB_0Offset_Front Side_10mm_Ch20850

Communication System: UID 0, LTE (0); Frequency: 2510 MHz;Duty Cycle: 1:1

Medium: HSL_2600 Medium parameters used: $f = 2510$ MHz; $\sigma = 1.931$ S/m; $\epsilon_r = 39.739$; $\rho = 1000$ kg/m³

Ambient Temperature : 23.2 °C; Liquid Temperature : 22.1 °C

DASY5 Configuration:

- Probe: EX3DV4 - SN3823; ConvF(6.98, 6.98, 6.98); Calibrated: 2018.11.12;
- Sensor-Surface: 4mm (Mechanical Surface Detection)
- Electronics: DAE4 Sn480; Calibrated: 2019.04.11
- Phantom: SAM 1; Type: QD000P40CC; Serial: TP:1471
- Measurement SW: DASY52, Version 52.8 (8); SEMCAD X Version 14.6.10 (7331)

Ch20850/Area Scan (111x111x1): Interpolated grid: dx=1.200 mm, dy=1.200 mm
Maximum value of SAR (interpolated) = 0.876 W/kg

Ch20850/Zoom Scan (7x7x7)/Cube 0: Measurement grid: dx=5mm, dy=5mm, dz=5mm

Reference Value = 8.341 V/m; Power Drift = -0.05 dB

Peak SAR (extrapolated) = 1.67 W/kg

SAR(1 g) = 0.748 W/kg; SAR(10 g) = 0.346 W/kg

Maximum value of SAR (measured) = 0.826 W/kg

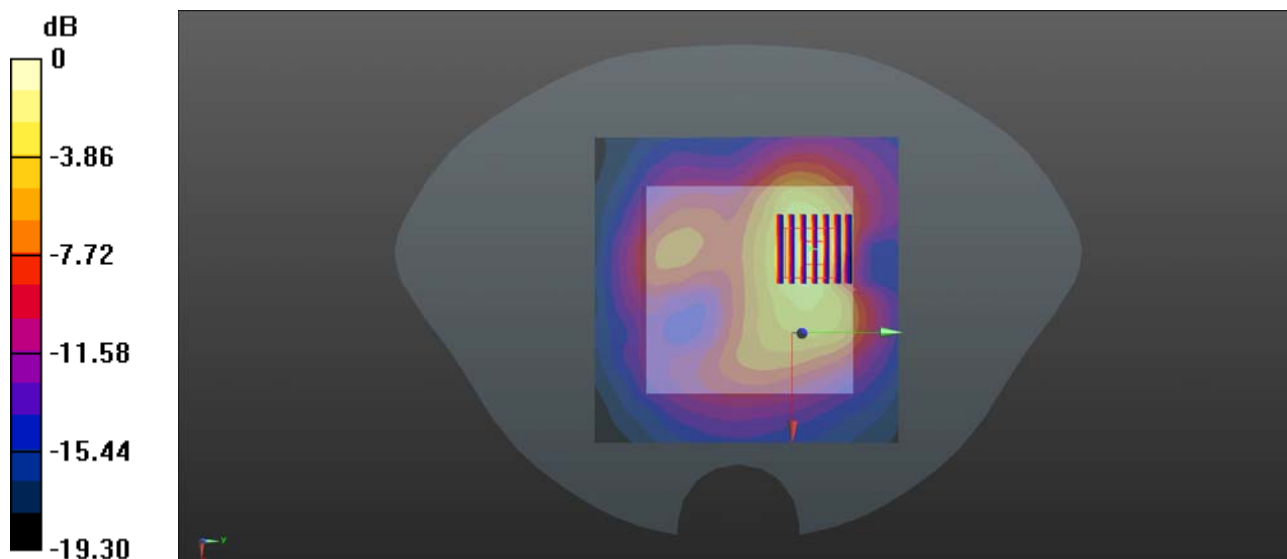

0 dB = 0.876 W/kg

LTE Band 38_20MHz_QPSK_1RB_0Offset_Front Side_10mm_Ch38000

Communication System: UID 0, LTE (0); Frequency: 2595 MHz; Duty Cycle: 1:1.59

Medium: HSL_2600 Medium parameters used: $f = 2595$ MHz; $\sigma = 2.027$ S/m; $\epsilon_r = 39.305$; $\rho = 1000$ kg/m³

Ambient Temperature : 23.2 °C; Liquid Temperature : 22.1 °C

DASY5 Configuration:

- Probe: EX3DV4 - SN3823; ConvF(6.98, 6.98, 6.98); Calibrated: 2018.11.12;
- Sensor-Surface: 4mm (Mechanical Surface Detection)
- Electronics: DAE4 Sn480; Calibrated: 2019.04.11
- Phantom: SAM 1; Type: QD000P40CC; Serial: TP:1471
- Measurement SW: DASY52, Version 52.8 (8); SEMCAD X Version 14.6.10 (7331)

Ch38000/Area Scan (71x61x1): Interpolated grid: dx=1.2000 mm, dy=1.2000 mm

Maximum value of SAR (interpolated) = 0.446 W/kg

Ch38000/Zoom Scan (5x5x7)/Cube 0: Measurement grid: dx=5mm, dy=5mm, dz=5mm

Reference Value = 4.131 V/m; Power Drift = 0.16 dB

Peak SAR (extrapolated) = 0.895 W/kg

SAR(1 g) = 0.415 W/kg; SAR(10 g) = 0.202 W/kg

Maximum value of SAR (measured) = 0.431 W/kg

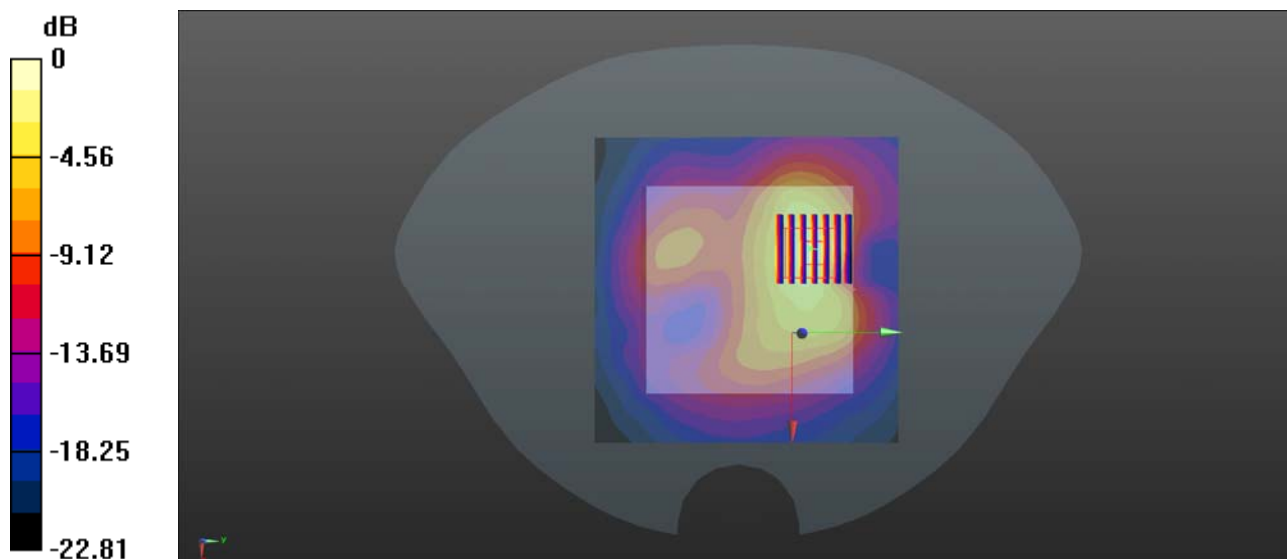

0 dB = 0.446 W/kg

LTE Band 40A_10MHz_QPSK_1RB_0Offset_Front Side_10mm_Ch38750

Communication System: UID 0, LTE (0); Frequency: 2310 MHz; Duty Cycle: 1:1.59

Medium: HSL_2300 Medium parameters used: $f = 2310$ MHz; $\sigma = 1.707$ S/m; $\epsilon_r = 41.263$; $\rho = 1000$ kg/m³

Ambient Temperature : 23.3 °C; Liquid Temperature : 22.3 °C

DASY5 Configuration:

- Probe: EX3DV4 - SN3823; ConvF(7.55, 7.55, 7.55); Calibrated: 2018.11.12;
- Sensor-Surface: 4mm (Mechanical Surface Detection)
- Electronics: DAE4 Sn480; Calibrated: 2019.04.11
- Phantom: SAM 1; Type: QD000P40CC; Serial: TP:1471
- Measurement SW: DASY52, Version 52.8 (8); SEMCAD X Version 14.6.10 (7331)

Ch38750/Area Scan (71x61x1): Interpolated grid: dx=1.2000 mm, dy=1.2000 mm
Maximum value of SAR (interpolated) = 0.637 W/kg

Ch38750/Zoom Scan (5x5x7)/Cube 0: Measurement grid: dx=5mm, dy=5mm, dz=5mm

Reference Value = 6.784 V/m; Power Drift = 0.04 dB

Peak SAR (extrapolated) = 1.11 W/kg

SAR(1 g) = 0.556 W/kg; SAR(10 g) = 0.283 W/kg

Maximum value of SAR (measured) = 0.624 W/kg

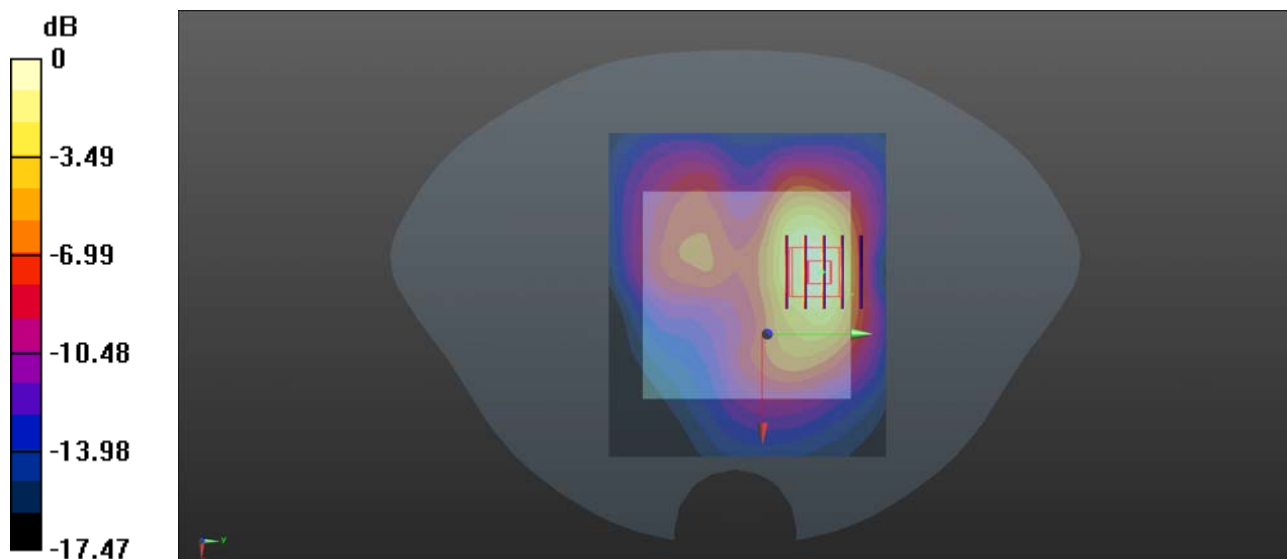

0 dB = 0.637 W/kg

LTE Band 40B_10MHz_QPSK_1RB_25Offset_Front Side_10mm_Ch39200

Communication System: UID 0, LTE (0); Frequency: 2355 MHz; Duty Cycle: 1:1.59

Medium: HSL_2300 Medium parameters used: $f = 2355$ MHz; $\sigma = 1.742$ S/m; $\epsilon_r = 41.172$; $\rho = 1000$ kg/m³

Ambient Temperature : 23.3 °C; Liquid Temperature : 22.3 °C

DASY5 Configuration:

- Probe: EX3DV4 - SN3823; ConvF(7.55, 7.55, 7.55); Calibrated: 2018.11.12;
- Sensor-Surface: 4mm (Mechanical Surface Detection)
- Electronics: DAE4 Sn480; Calibrated: 2019.04.11
- Phantom: SAM 1; Type: QD000P40CC; Serial: TP:1471
- Measurement SW: DASY52, Version 52.8 (8); SEMCAD X Version 14.6.10 (7331)

Ch39200/Area Scan (71x61x1): Interpolated grid: dx=1.2000 mm, dy=1.2000 mm

Maximum value of SAR (interpolated) = 0.546 W/kg

Ch39200/Zoom Scan (5x5x7)/Cube 0: Measurement grid: dx=5mm, dy=5mm, dz=5mm

Reference Value = 6.548 V/m; Power Drift = -0.1 dB

Peak SAR (extrapolated) = 1.04 W/kg

SAR(1 g) = 0.468 W/kg; SAR(10 g) = 0.28 W/kg

Maximum value of SAR (measured) = 0.576 W/kg

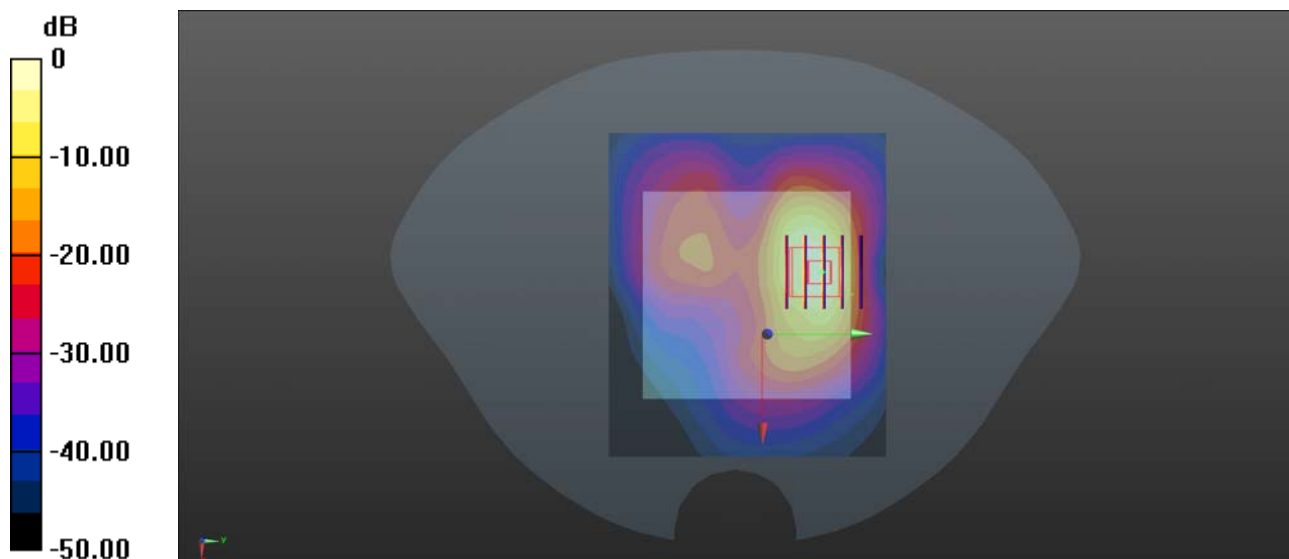

0 dB = 0.576 W/kg

LTE Band 41_20MHz_QPSK_1RB_0Offset_Front Side_10mm_Ch40340

Communication System: UID 0, LTE (0); Frequency: 2565 MHz; Duty Cycle: 1:1.59

Medium: HSL_2600 Medium parameters used: $f = 2565$ MHz; $\sigma = 1.99$ S/m; $\epsilon_r = 39.526$; $\rho = 1000$ kg/m³

Ambient Temperature : 23.2 °C; Liquid Temperature : 22.1 °C

DASY5 Configuration:

- Probe: EX3DV4 - SN3823; ConvF(6.98, 6.98, 6.98); Calibrated: 2018.11.12;
- Sensor-Surface: 4mm (Mechanical Surface Detection)
- Electronics: DAE4 Sn480; Calibrated: 2019.04.11
- Phantom: SAM 1; Type: QD000P40CC; Serial: TP:1471
- Measurement SW: DASY52, Version 52.8 (8); SEMCAD X Version 14.6.10 (7331)

Ch40340/Area Scan (101x101x1): Interpolated grid: dx=1.200 mm, dy=1.200 mm
Maximum value of SAR (interpolated) = 0.594 W/kg

Ch40340/Zoom Scan (7x7x7)/Cube 0: Measurement grid: dx=5mm, dy=5mm, dz=5mm
Reference Value = 5.147 V/m; Power Drift = 0.18 dB
Peak SAR (extrapolated) = 1.07 W/kg
SAR(1 g) = 0.515 W/kg; SAR(10 g) = 0.252 W/kg
Maximum value of SAR (measured) = 0.563 W/kg

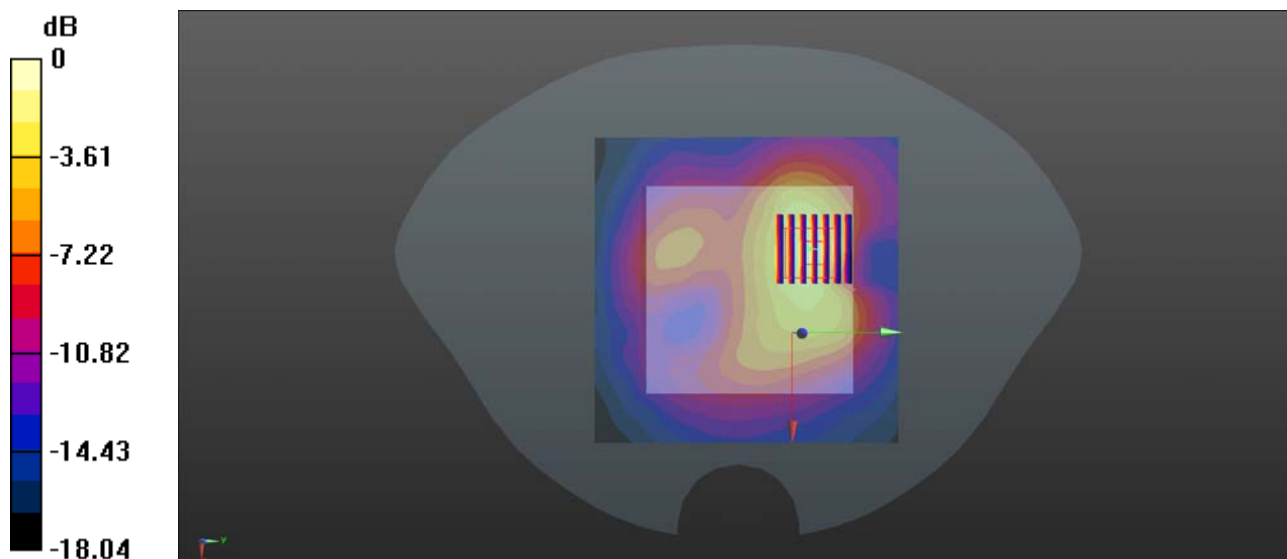

0 dB = 0.594 W/kg

WLAN2.4GHz_802.11b 1Mbps_Back Side_10mm_Ch11_Ant 1

Communication System: UID 0, WLAN 2.4GHz 802.11b (0); Frequency: 2462 MHz; Duty Cycle: 1:1
Medium: HSL_2450 Medium parameters used: $f = 2462$ MHz; $\sigma = 1.869$ S/m; $\epsilon_r = 39.88$; $\rho = 1000$

kg/m³

Ambient Temperature : 23.4 °C; Liquid Temperature : 22.5 °C

DASY5 Configuration:

- Probe: EX3DV4 - SN3823; ConvF(7.34, 7.34, 7.34); Calibrated: 2018.11.12;
- Sensor-Surface: 4mm (Mechanical Surface Detection)
- Electronics: DAE4 Sn480; Calibrated: 2019.04.11
- Phantom: SAM 1; Type: QD000P40CC; Serial: TP:1471
- Measurement SW: DASY52, Version 52.8 (8); SEMCAD X Version 14.6.10 (7331)

Ch11/Area Scan (101x101x1): Interpolated grid: dx=1.200 mm, dy=1.200 mm

Maximum value of SAR (interpolated) = 0.0942 W/kg

Ch11/Zoom Scan (7x7x7)/Cube 0: Measurement grid: dx=5mm, dy=5mm, dz=5mm

Reference Value = 2.126 V/m; Power Drift = 0.05 dB

Peak SAR (extrapolated) = 0.174 W/kg

SAR(1 g) = 0.084 W/kg; SAR(10 g) = 0.043 W/kg

Maximum value of SAR (measured) = 0.0901 W/kg

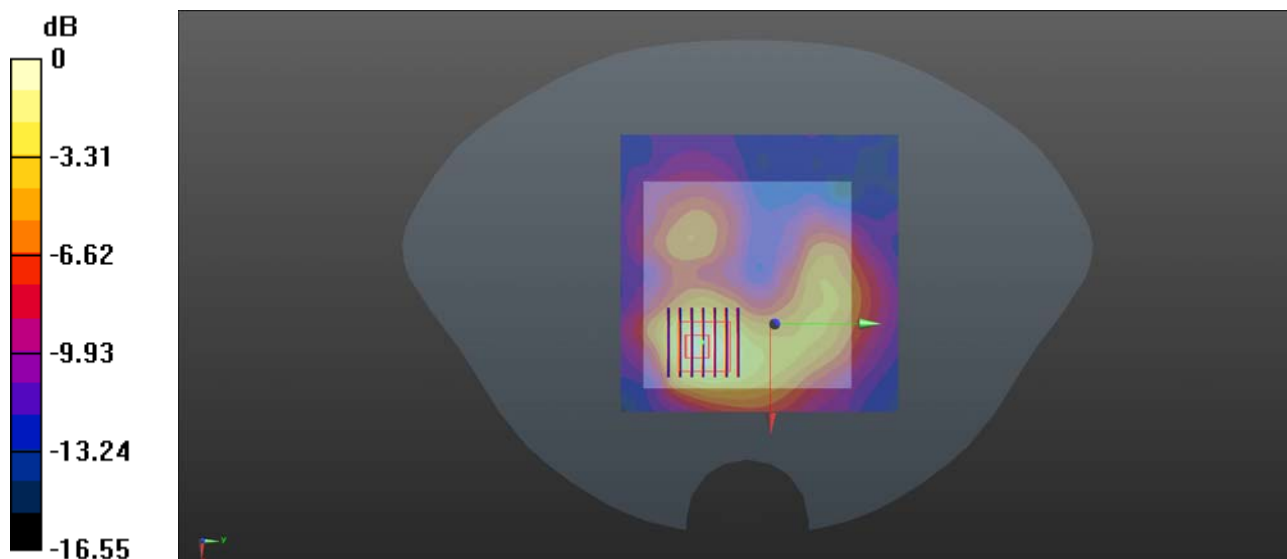

0 dB = 0.0942 W/kg

WLAN 5GHz Band 1_802.11n-HT40 MCS0_Front Side_10mm_Ch46_Ant 0

Communication System: UID 0, WLAN 5GHz (0); Frequency: 5230 MHz;Duty Cycle: 1:1
Medium: HSL_5250 Medium parameters used: $f = 5230 \text{ MHz}$; $\sigma = 4.676 \text{ S/m}$; $\epsilon_r = 36.093$; $\rho = 1000 \text{ kg/m}^3$

Ambient Temperature : 23.2 °C; Liquid Temperature : 22.8 °C

DASY5 Configuration:

- Probe: EX3DV4 - SN3823; ConvF(5.28, 5.28, 5.28); Calibrated: 2018.11.12;
- Sensor-Surface: 2mm (Mechanical Surface Detection)
- Electronics: DAE4 Sn480; Calibrated: 2019.04.11
- Phantom: SAM 2; Type: QD000P40CC; Serial: TP:1464
- Measurement SW: DASY52, Version 52.8 (8); SEMCAD X Version 14.6.10 (7331)

Ch46/Area Scan (131x131x1): Interpolated grid: $dx=1.000 \text{ mm}$, $dy=1.000 \text{ mm}$
Maximum value of SAR (interpolated) = 0.0923 W/kg

Ch46/Zoom Scan (8x8x15)/Cube 0: Measurement grid: $dx=4\text{mm}$, $dy=4\text{mm}$, $dz=2\text{mm}$
Reference Value = 2.038 V/m; Power Drift = -0.09 dB
Peak SAR (extrapolated) = 0.0960 W/kg
SAR(1 g) = 0.08 W/kg; SAR(10 g) = 0.041 W/kg
Maximum value of SAR (measured) = 0.0923 W/kg

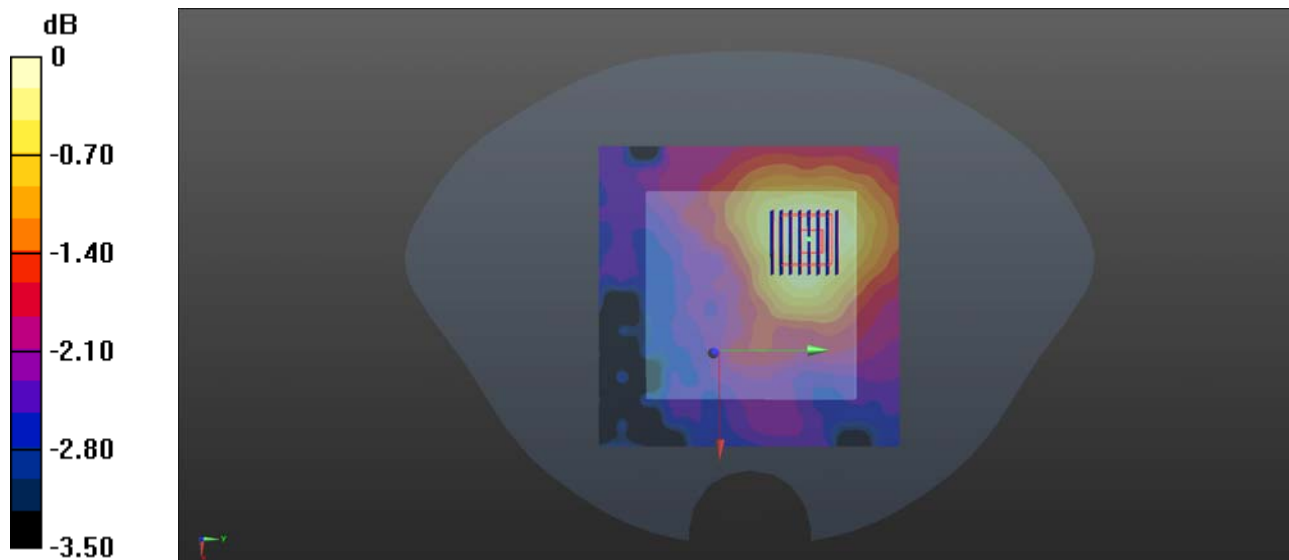

0 dB = 0.0923 W/kg = -13.88 dBW/kg

WLAN 5GHz Band 4_802.11n-HT40 MCS0_Top Side_10mm_Ch151_Ant 0

Communication System: UID 0, WLAN 5GHz (0); Frequency: 5755 MHz;Duty Cycle: 1:1
Medium: HSL_5750 Medium parameters used: $f = 5755$ MHz; $\sigma = 5.306$ S/m; $\epsilon_r = 35.15$; $\rho = 1000$ kg/m³

Ambient Temperature : 23.2 °C; Liquid Temperature : 22.8 °C

DASY5 Configuration:

- Probe: EX3DV4 - SN3823; ConvF(4.6, 4.6, 4.6); Calibrated: 2018.11.12;
- Sensor-Surface: 2mm (Mechanical Surface Detection)
- Electronics: DAE4 Sn480; Calibrated: 2019.04.11
- Phantom: SAM 2; Type: QD000P40CC; Serial: TP:1464
- Measurement SW: DASY52, Version 52.8 (8); SEMCAD X Version 14.6.10 (7331)

Ch151/Area Scan (71x131x1): Interpolated grid: dx=1.000 mm, dy=1.000 mm
Maximum value of SAR (interpolated) = 0.734 W/kg

Ch151/Zoom Scan (8x8x15)/Cube 0: Measurement grid: dx=4mm, dy=4mm, dz=2mm
Reference Value = 3.641 V/m; Power Drift = -0.03 dB
Peak SAR (extrapolated) = 3.13 W/kg
SAR(1 g) = 0.750 W/kg; SAR(10 g) = 0.308 W/kg
Maximum value of SAR (measured) = 0.723 W/kg

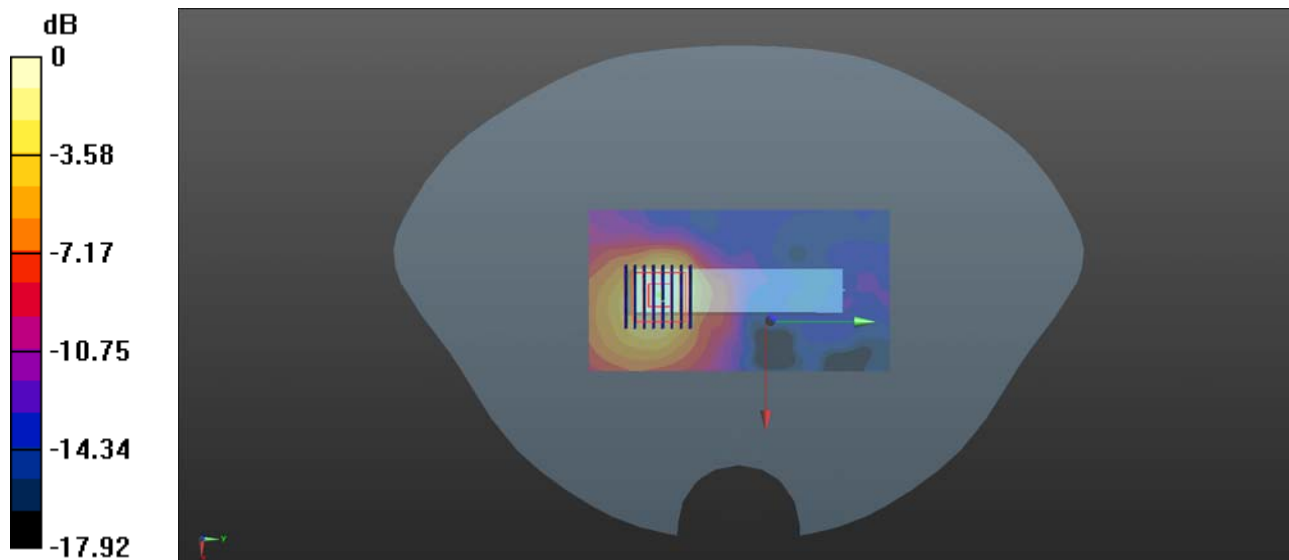

0 dB = 0.734 W/kg