

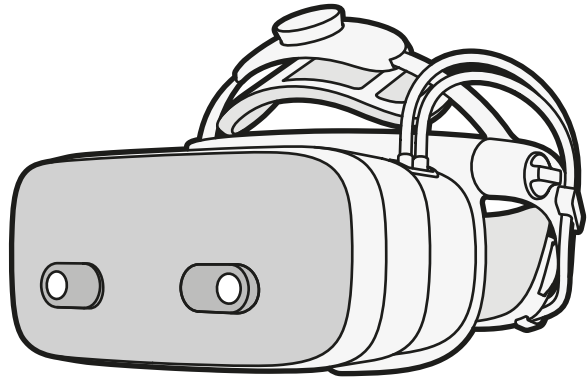

# User guide

XR-3

VR-3

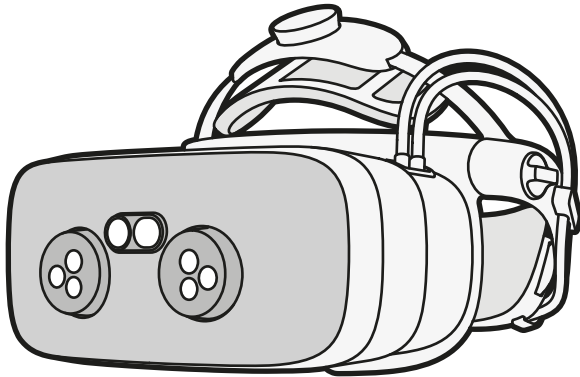

[User guide](#) **EN**

[Benutzerhandbuch](#) **DE**

[Mode d'emploi](#) **FR**

[Guía del usuario](#) **ES**

[Manuale d'uso](#) **IT**

[Käyttöohje](#) **FI**

[Användarguide](#) **SV**

[ユーザーガイド](#) **JP**

[사용자 설명서](#) **KO**

[Hebrew](#) **HE**

XR-3

mixed reality headset

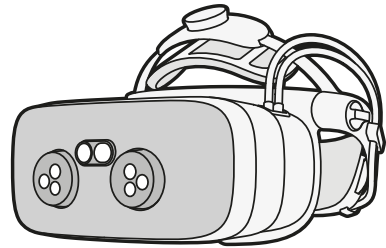

2 headset adapters

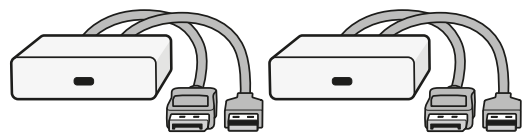

2 power supply units

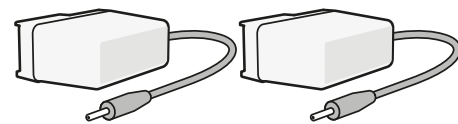

6 power plugs, 2 of each

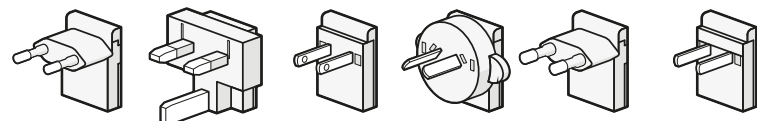

EURO

UK

US

AUS

KOR

CHN

Cleaning cloth

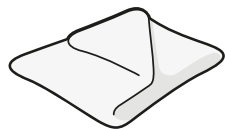

Varjo reference marker

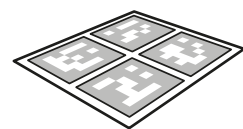

VR-3

virtual reality headset

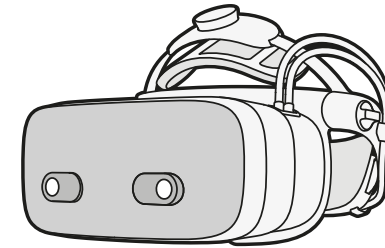

2 headset adapters

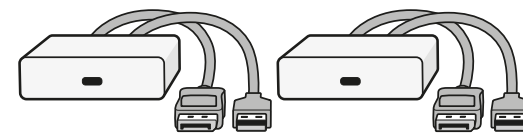

2 power supply units

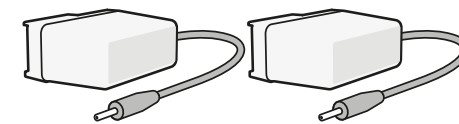

6 power plugs, 2 of each

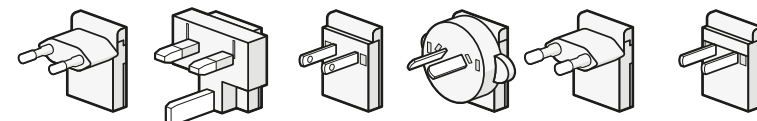

EURO

UK

US

AUS

KOR

CHN

Cleaning cloth

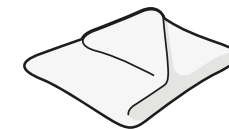

## Connect the headset

Varjo headsets are compatible with Windows 10 computers.

1. **A** and **B** : Connect each headset cable to a headset adapter.
2. Headset adapters: Connect each adapter to a DisplayPort port on the graphics card and to a USB-A 3.0 / 3.1 port on the motherboard.

For more detailed system requirements, see [varjo.com/start/system](https://www.varjo.com/start/system) .

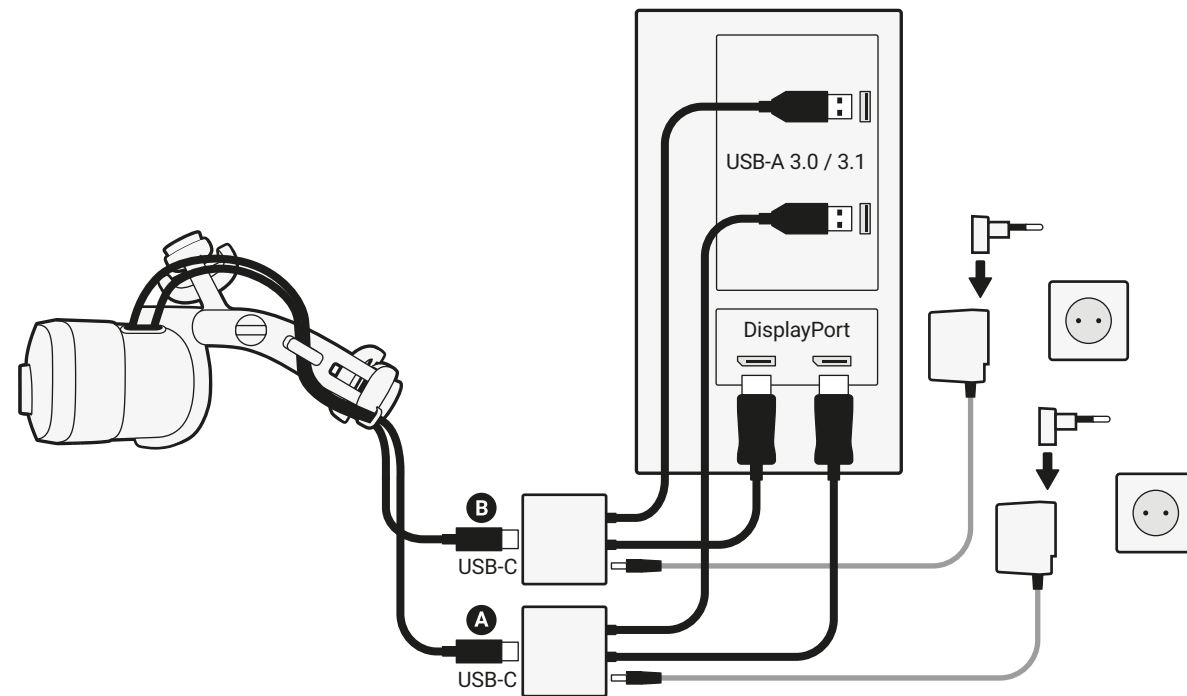

## Download Varjo Base

Varjo Base is the software used to run your headset on a Windows 10 computer.

Download Varjo Base to get started.

1. Go to [varjo.com/start](https://www.varjo.com/start) .
2. Create a Varjo Account.
3. Download and start Varjo Base.
4. Follow the setup instructions.

You will need a valid subscription to use your headset.

Read more at [varjo.com/subscriptions](https://www.varjo.com/subscriptions) .

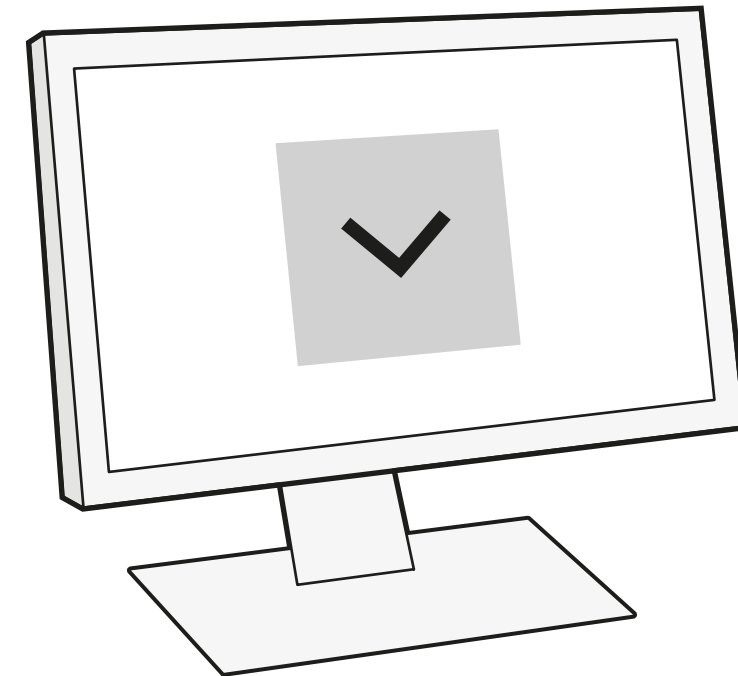

## Put on the headset

To put on the headset, place the front of the headset on your face and pull the headband over the back of your head. You can wear most single-vision eyeglasses while using the headset.

Adjust the fit and comfort of the headset when you put it on:

- ① : Rotate the back adjustment wheel to tighten the headband.
- ② : Rotate the front adjustment wheel to move the headset up or down on your head. Support the headset body with one hand while adjusting.
- ③ and ④ : Use the side knobs to adjust how the headset fits around your face.

The headset is correctly adjusted when it sits comfortably on your head and the image inside the headset is sharp.

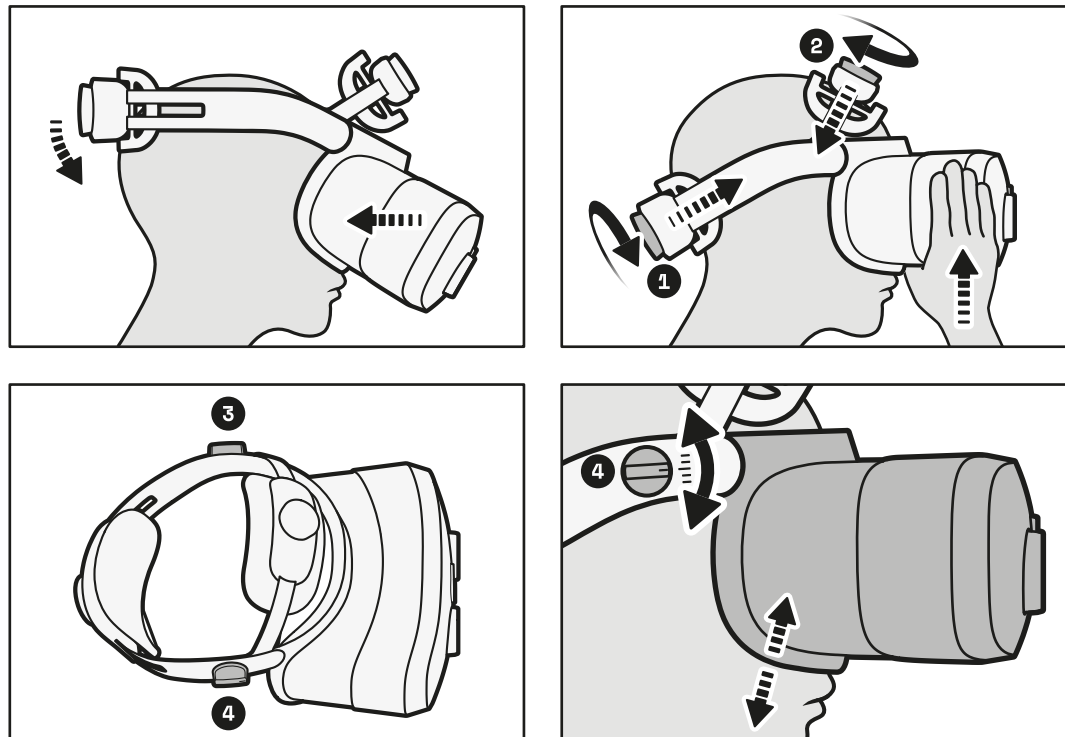

## Using the headset

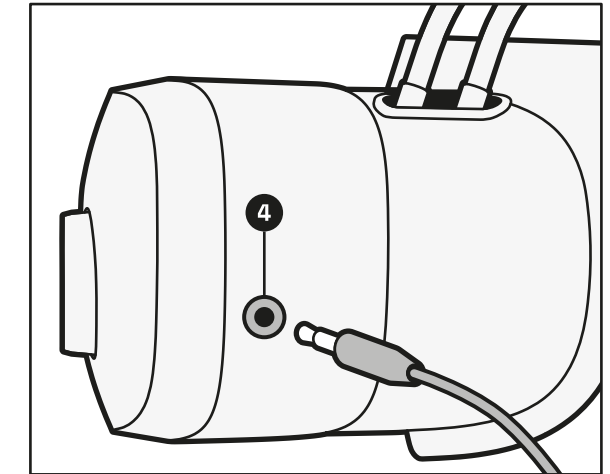
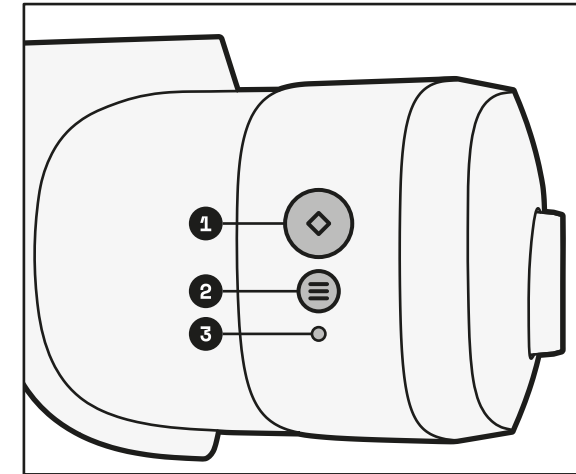

① Action button: interact with your applications

② Menu button: open the Menu

③ LED status light

④ Headphone connector

LED pattern	Headset status
White (blinking)	Starting up
Green (solid)	Working normally
Green (pulsing)	Idle
Green (blinking)	Shutting down
Orange (solid)	Varjo Base not running

## Cleaning the headset

Clean the headset regularly, especially when sharing a headset with others.

Headset lenses: clean gently with optical lens wipes or a microfiber lens cloth.

Headset body, cushions, nose area, and areas surrounding the lenses: clean with non-abrasive antibacterial wipes.

You can purchase additional cushions from Varjo Store.



## Using the Varjo reference marker

Use the Varjo reference marker to improve the accuracy of Varjo inside-out tracking.

Varjo inside-out tracking is available for the Varjo XR-3 mixed reality headset.

For more information, visit [varjo.com/start/get-to-know-your-headset](https://www.varjo.com/start/get-to-know-your-headset).

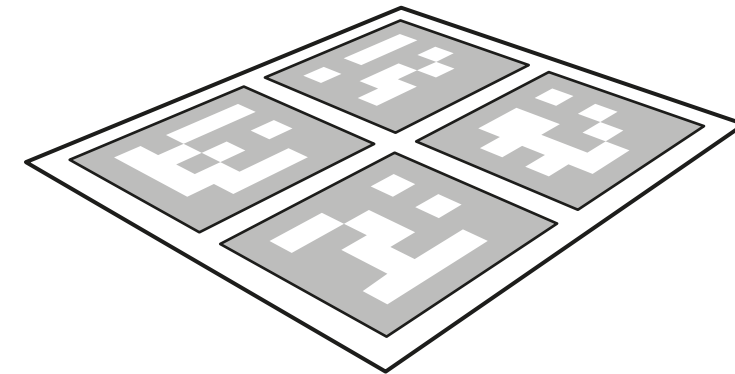

# Product and safety information

## Intended use

The headset is intended to be used indoors and by adults only. If you do not use the headset as intended, it may cause the headset to malfunction.

## High-risk use

Varjo software and/or products are not designed, engineered, or certified for control of any equipment or system, including aviation, industrial, commercial, military, or medical equipment or systems, in a way where such use or a malfunction of the software or products could with a meaningful probability lead to death or serious bodily injury of any person or animal, or to severe physical or environmental damage ("high-risk use"). VARJO STRONGLY ADVISES AGAINST USING THE SOFTWARE OR PRODUCTS FOR ANY HIGH-RISK USE. If you still decide to use the software and/or products for high-risk use, you do so at your own risk, assume all liability, and agree to take all reasonable precautions to minimize any risk and damage resulting from such high-risk use and/or failure of software and/or products in such high-risk use.

## Product type label

The model name and serial number of the headset are printed on the type label located on the back support of the headband.

## Health and safety warnings

To reduce the risk of personal injury, discomfort, or property damage, please ensure that all users of the headset carefully read the warnings below before using the headset.

### Before using the headset

A comfortable mixed or virtual reality experience requires an unimpaired sense of motion and balance. Do not use the headset if you are sick, tired, sleepy, under the influence of alcohol or drugs, hungover, experiencing digestive problems, under emotional stress or anxiety, suffering from cold, flu, migraines, or headaches, or are not generally feeling well, as it may worsen your condition. Consult a doctor before using the headset if you have any conditions that impair your vision or mobility, are pregnant or elderly, have a heart or other serious medical condition, or suffer from seizures, migraines, or psychiatric conditions.

### Safe environment

Varjo headsets produce an immersive mixed or virtual reality experience that may distract you and make it hard to see your actual surroundings.

- Remember that any virtual objects that you see do not exist in the real environment, and their size and location are not real. Do not attempt to sit or stand on virtual objects or use them for support. Be aware of any real-world objects that might be located behind virtual objects.
- Never use the headset in situations that require attention, such as while walking, bicycling, or driving. Do not use the headset while in a moving vehicle.
- Remember that while you are using the headset, you may be unaware of people entering the area.
- Before using the headset, clear the area of obstacles and hazards, people, furniture, and any other items that may prevent you from moving freely. Also, check that you have enough space above and around you so that you can extend your arms while using the headset.
- Do not use the headset near walls, stairs, balconies, windows, open doorways, low ceilings, ceiling fans, light fixtures, breakable items, open flames, heat sources, or any other items that you can collide with or knock down.
- Keep in mind the location of the cables and power cords so that you do not walk on, trip over, or pull on them while using the headset. Do not jerk, knot, or bend the cables or cords.
- Do not handle sharp or otherwise dangerous objects while using the headset.

### Discomfort

When using the headset, some people may experience dry eyes, eye strain, eye or muscle twitching, involuntary movements, altered, blurred or double vision, or other visual abnormalities, dizziness, light headedness, disorientation, discomfort or pain in the head or eyes, headaches, impaired balance, impaired hand-eye coordination, excessive sweating, increased salivation, nausea, fatigue, loss of awareness, or seizures and other symptoms of motion sickness.

When you start to use the headset, keep your first sessions short and take regular breaks. If you feel discomfort, stop using the headset and continue only after the symptoms have ended. Do not drive, operate machinery, or engage in other visually or physically demanding activities until you have fully recovered from any symptoms. Consider consulting a doctor if you are not able to see virtual objects clearly and comfortably.

### Overuse

Take regular breaks when using the headset. Prolonged use may impact your hand-eye coordination or balance and may cause other negative effects.

### Repetitive stress injuries

Use the headset in a comfortable position. Do not use excessive force when gripping the headset or pressing the headset buttons. If you experience tingling, numbness, burning, stiffness, throbbing, or other discomfort, stop using the headset and rest until you have fully recovered from any symptoms. If you continue to experience these symptoms, consult a doctor.

### Interference with medical devices

The headset may emit radio waves, which can affect the operation of nearby electronics, including cardiac pacemakers, hearing aids, and defibrillators. If you use a pacemaker or other implanted medical device, do not use the headset without first consulting a doctor or the manufacturer of your medical device. Maintain a safe distance between the headset and your medical devices and stop using the headset if you observe any interference with your medical device.

### Hearing loss

Excessive exposure to loud sounds can cause hearing damage. When using headphones with the headset, start with the volume at a low level and increase the volume slowly if needed. Do not turn up the volume too high.

### Seizures

Some people may experience severe dizziness, fainting, epileptic seizures, or blackouts triggered by light flashes, patterns, or exposure to infrared light sources of an eye tracker even though they have no history of these conditions. If you experience any of these symptoms, stop using the headset and consult a doctor. If you have a previous history with these symptoms, consult a doctor before using the headset. To reduce the likelihood of a seizure, do not use the headset if you are tired.

### No eye protection

Varjo headsets do not provide eye protection against impact, debris, chemicals, UV light, other harmful lights, particles, projectiles, or other physical hazards.

### Electrical shock

Do not try to disassemble, open, service, or modify the headset or power supply unit, as this can lead to electrical shock or other hazards and may damage the headset or the power supply unit. For PLUGGABLE EQUIPMENT, the socket-outlet shall be installed near the equipment and shall be easily accessible. Use the headset only with the power supply unit (Adapter Technology Co., Ltd. (ATS036T-W120V(Level VI)) INPUT Universal 100 ~ 240 Vac / 50 ~ 60 Hz, 1A, OUTPUT +12V / 0~3A and headset adapter included in the sales box. Using other power supply units may be dangerous.

## CLASS 1 LASER PRODUCT

(Applicable only to the Varjo XR-3 mixed reality headset)

### Damaged or broken device

Do not use the headset if any part is broken or damaged, the provided cables are torn, or any wires are exposed. Do not try to repair any part of the headset yourself. Repairs should be made only by an authorized service facility or Varjo.

### Contagious conditions

To avoid the risk of transferring contagious conditions from one person to another, do not share the headset with persons with infections or diseases, particularly of the eyes, skin, or scalp.

### Skin irritation

Stop using the headset if you experience swelling, itchiness, or other irritation. If the symptoms persist, consult a doctor.

## Safety information

To prevent injury to yourself or others or damage to the headset, read this safety information before using the headset.

### Wearing the headset

When you put on the headset for the first time, follow the instructions on how to position the headset correctly on your head. The headset is correctly adjusted when it sits comfortably on your head and the image inside the headset is sharp. There should be no pain or pressure on your head, and the cushion should feel comfortable on your face.

When you put on the headset, it will adjust the lenses automatically based on your interpupillary distance. This setting is on by default. We recommend that you keep the setting on. Switch off the setting if the automatic adjustment does not work for you, for example due to eyeglasses, sensitivity to infrared light, or any conditions that impair your vision. If you switch off the automatic adjustment, you may feel discomfort when using the headset.

## Lighting

Use the headset in a well-lit environment to get the maximum performance from the cameras on the headset. Please be aware that reflective surfaces may interfere with positional tracking.

## Care and maintenance

Handle the headset with care and keep it in a clean and dust-free place.

## Sunlight and external light sources

Do not leave the headset in direct sunlight or strong ultraviolet light. Exposure to direct sunlight can damage the optics and display. Do not shine a laser or an external light source through the lenses.

## ! Damage

- Do not drop or bend the headset or knock it against other objects, as this may affect the calibration of the camera lenses.
- Do not scratch the camera lenses.
- Lift the headset by holding the headset body or the headband.
- Do not lift the headset by holding the cushions or cables.
- Do not step on the cables.

## ! Damage requiring service

Use only qualified personnel to service the headset. Contact an authorized service facility if:

- The headset has been exposed to liquid or dropped.
- The headset has been subjected to impact or is damaged.
- The headset overheats.
- The headset does not operate normally when you follow the operating instructions.

## Cleaning

Unplug the headset from its power source before cleaning. Clean the headset body with non-abrasive anti-bacterial wipes. Do not use soap, harsh chemicals, alcohol, cleaning solvents, liquid cleansers,

or aerosols. Never use water to clean the headset. Clean the headset lenses and front plate gently with optical lens wipes or a microfiber lens cloth. Do not clean the lenses with any liquid or chemical cleansers. Clean the cushions with non-abrasive anti-bacterial wipes.

## Device temperature

It is normal for the headset to feel warm to the touch while in use. The front-facing cameras and air ventilation surfaces in particular may get hot. Prolonged skin contact with a headset that is hot to the touch may cause skin discomfort or redness, or low temperature burns. If your headset feels hot to the touch or is uncomfortably warm, stop using it and allow the headset to cool down.

## Accessories

Do not use the headset with any unauthorized or incompatible accessories or software. Using unauthorized accessories or software may cause performance issues or result in injury or damage. Check [varjo.com/support](http://varjo.com/support) for a list of compatible accessories or software.

## Operating and storage environment

### Placement

Use the headsets only in adequately ventilated areas.

- Do not cover the headset.
- Do not cover the ventilation holes on top or at the bottom of the headset.
- Do not place the headset near objects that could scratch the lenses.
- Do not expose the headset to open flames or lit smoking products.
- Do not place the headset near heat sources, hot areas, or extreme temperatures.
- Do not use the headset near water or other liquids.
- Do not use the headset after a dramatic change in temperature. When you move the headset between environments with very different temperatures and/or humidity ranges, condensation may form on or inside the headset. Allow enough time for the moisture to evaporate before using the headset.

**Note:** When you move the headset from low-temperature conditions into a warmer environment or vice versa, allow the headset to acclimate to room temperature before you turn it on. Use the headset at temperatures between 10°C to 27°C (50° to 80°F). Store the headset in its sales box at temperatures between 0°C to 40°C (32°F to 104°F) to minimize unintentional damage.

## Radio frequencies

Component	Rating	Frequency	Peak Output Power
Headset	5V, 2A	2.402–2.48 GHz	0.58 mW

## Recycling

The Directive 2012/19/EU on Waste Electrical and Electronic Equipment (WEEE), which entered into force on 13th February 2003, resulted in a major change in the treatment of electrical equipment at end-of-life. Check the local regulations for proper disposal of electronic products.



The crossed-out wheellie bin symbol on your headset, battery, reading materials, or packaging reminds you to take all electrical and electronic products, batteries, and used packaging materials to separate collection at the end of their working life. Do not dispose of these products as unsorted municipal waste; take them for recycling. For info on your nearest recycling point, check with your local waste authority.

## CE European Union notice

Hereby, Varjo declares that the HS-5 and HS-6 headsets are in compliance with Directive 2014/53/EU. The full text of the EU declaration of conformity is available at the following internet address: [varjo.com/compliance](http://varjo.com/compliance).

**Note:** This equipment has been tested and found to comply with the limits for Criterion C.

A direct ESD discharge of +/-500V or more to the camera assembly can result in reduced functionality. The camera system may need to be restarted to restore full functionality.

## FC FCC and ISED Information to the user

**Note:** This equipment has been tested and found to comply with the limits for a Class A digital device, pursuant to part 15 of the FCC Rules. These limits are designed to provide reasonable protection against harmful interference when the equipment is operated in a commercial environment. This equipment generates, uses, and can radiate radio frequency energy and, if not installed and used in accordance with the instruction manual, may cause harmful

interference to radio communications. Operation of this equipment in a residential area is likely to cause harmful interference, in which case the user will be required to correct the interference at their own expense.

This Class A digital apparatus complies with the Canadian standard ICES-003. Cet appareil numérique de Classe A est conforme à la norme Canadienne ICES-003.



## California Proposition 65

**WARNING:** Cancer - [www.P65Warnings.ca.gov](http://www.P65Warnings.ca.gov).

## FCC and ISED Compliance statement

This device complies with part 15 of the FCC Rules and to RSS-247 of Innovation, Science and Economic Development Canada. Operation is subject to the following two conditions: (1) this device may not cause harmful interference, and (2) this device must accept any interference received, including interference that may cause undesired operation. Changes or modifications not expressly approved by the party responsible for compliance could void the user's authority to operate the equipment.

Cet appareil se conforme aux normes RSS-247 exemptés de licence d'Innovation, Sciences et Développement économique Canada. L'opération est soumise aux deux conditions suivantes : (1) cet appareil ne doit causer aucune interférence, et (2) cet appareil doit accepter n'importe quelle interférence, y compris l'interférence qui peut causer une opération non souhaitée de cet appareil. Les changements ou modifications n'ayant pas été expressément approuvés par la partie responsable de la conformité peuvent faire perdre à l'utilisateur l'autorisation de faire fonctionner le matériel.

## FCC and ISED Radiation Exposure statement

This equipment complies with FCC and Canadian radiation exposure limits set forth for an uncontrolled environment. This transmitter must not be co-located or operating in conjunction with any other antenna or transmitter. Cet équipement est conforme à RSS-102 limites énoncées pour un environnement non contrôlé.

## RoHS compliance

This equipment is in compliance with Directive 2011/65/EU of the European Parliament and of the Council of 8 June 2011, on the restriction of the use of certain hazardous substances in electrical and electronic equipment (RoHS) and its amendments.



# Varjo Limited Business Warranty

VARJO PRODUCT IS INTENDED FOR BUSINESS USE AND IS NOT INTENDED TO BE SOLD TO CONSUMERS. THIS LIMITED BUSINESS WARRANTY GIVES YOU SPECIFIC LEGAL RIGHTS AND YOU MAY ALSO HAVE OTHER LEGAL RIGHTS WHICH VARY FROM STATE TO STATE AND COUNTRY TO COUNTRY.

## 1. Definitions.

The following definitions apply to this Limited Warranty:

- “Varjo Product” means the Varjo headset and any accessories provided in the box at the time of the original purchase from an authorized retailer or Varjo (“Authorized Retailer”).
- “You” and “Your” refer to the original business user who bought the Varjo Product from an Authorized Retailer.
- “Warranty Period” is twelve (12) months from the date You purchased the Varjo Product from an Authorized Retailer.
- “Normal Use Conditions” means ordinary business use in accordance with the User Manual.
- “User Manual” means any and all use instructions, safety guidance and other documentation provided in the box or posted online by Varjo.

## 2. Coverage

Varjo warrants, exclusively to You, that during the Warranty Period the Varjo Product will function substantially in accordance with Varjo’s technical specifications under Normal Use Conditions. This Limited Warranty does not cover any software or other products required to use the Varjo Product which are not in the box at the time of the original purchase of the Varjo Product. Such products are subject to their own use or other terms, even if intended or labelled to be used together with the Varjo Product.

This Limited Warranty is valid and enforceable only if You purchased the new Varjo Product from an Authorized Retailer and the Varjo Product was sold to You in its original, sealed packaging. You may not assign or transfer this Limited Warranty to any third party, unless such restriction is prohibited by mandatory law.

If You return the Varjo Product during the Warranty Period and it satisfies the terms of this Limited Warranty, Varjo or its service partner will, at its sole discretion, repair or replace it.

Repair or replacement may involve the use of a functionally equivalent reconditioned Varjo Product and/or reconditioned parts, unless prohibited by law. When replacing the Varjo Product, Varjo may replace it with either the same model, or if not available, a model which is nearest to the original model. Varjo or its service partner will

at its own expense return the repaired or replacement Varjo Product to You. Any Varjo Product that You send to Varjo and that is replaced by Varjo becomes the property of Varjo.

If Varjo repairs or replaces the Varjo Product, the repaired or replaced Varjo Product shall continue to be warranted for the remaining time of the original Warranty Period or for three (3) months from the date of the repair or replacement, whichever is longer.

Repair or replacement of the Varjo Product is Your sole and exclusive remedy and Varjo’s sole obligation for any claims whatsoever or any losses resulting from the failure of the Varjo Product. If we determine, in our sole discretion, that none of the listed means is reasonable to fix the defect or malfunction, then we may refund to You the price You paid to purchase the Product.

This Limited Warranty is the final, complete and exclusive warranty offered by Varjo regarding the Varjo Product, and no other person or entity (including the Authorized Reseller) is authorized to make any other warranties or representations on behalf of Varjo. EXCEPT FOR THE EXPRESS LIMITED WARRANTIES PROVIDED IN THIS LIMITED WARRANTY, VARJO DISCLAIMS ALL OTHER EXPRESS AND IMPLIED WARRANTIES AND REPRESENTATIONS OF ANY KIND, INCLUDING ANY IMPLIED WARRANTY OF MERCHANTABILITY, AND FITNESS FOR A PARTICULAR PURPOSE. EXCEPT OTHERWISE PROVIDED IN THIS LIMITED WARRANTY, ALL VARJO PRODUCTS ARE PROVIDED “AS IS” AND “WITH ALL FAULTS”. If and to the extent that an implied warranty cannot be disclaimed, its duration is limited to the Warranty Period. If the mandatory law applicable to You does not allow limitations on how long an implied warranty lasts, this limitation may not apply to You.

In case you are not the original purchaser of the Varjo Product, this Limited Warranty does not apply to you. If the Warranty Period has expired, if the Varjo Product does not fulfill the conditions of this Limited Warranty or if You fail to make Your warranty claim in accordance with Section 5, this Limited Warranty does not apply. In case this Limited Warranty does not apply, Varjo may offer You out-of-warranty services against a fee and You may be responsible for any expenses related to the repair or replacement of Your Varjo Product.

## 3. How Can You Get Service?

If You have a problem with Your Varjo Product, please visit us at [varjo.com/support](https://www.varjo.com/support) to get assistance and contact information and to submit a claim form to obtain warranty service. If it is necessary for You to send Your Varjo Product in for service, we will provide You instructions on how to do this. You may be required to pay the cost of shipping the Varjo Product to us. When we receive the Varjo

Product, we will determine if there is a defect or malfunction covered by this Limited Warranty. If we find a defect or malfunction covered by this Limited Warranty, we will repair or replace the Varjo Product to provide You a Varjo Product that is substantially in accordance with Varjo’s technical specifications under Normal Use Conditions and we will send the repaired Varjo Product or a replacement Varjo Product, if any, to You at our cost. We may not return the original Varjo Product to You. If You send us a Varjo Product without a valid proof of purchase, we will return the Varjo Product to You at Your cost, subject to prepayment, or, if such costs are not prepaid, we will keep the Varjo Product thirty (30) days waiting for Your pick-up before it is disposed of.

## 4. What is not covered?

This Limited Warranty does not cover and Varjo is not responsible for (i) used or resold Varjo Products; (ii) Varjo Products not purchased from Authorized Retailers; or (iii) any software (including but not limited to any software on the Varjo product and any PC software provided by Varjo).

Furthermore, this Limited Warranty does not cover and Varjo is not responsible for damage to the Varjo Product or loss of the Varjo Product or resulting from (i) an accident (e.g. accidental physical impact, exposure to liquid, food or other contaminants, etc.) or theft; (ii) use not in accordance with Normal Use Conditions or any other misuse (including but not limited to neglect, abuse or alteration); (iii) use with an unsuitable product not sold or licensed by Varjo; (iv) use with inadequate ventilation; (v) use by children; (vi) circumvention of our security mechanisms; (vii) reverse engineering; (viii) defects or damage from viruses or other software problems introduced into the Varjo Product; (ix) use of the Varjo Product in violation of any laws, regulations or ordinances in effect where the Varjo Product is used; (x) defects or damage caused by unauthorized repairs; (xi) Acts of God, including but not limited to lightning, flood, tornado, earthquake or hurricane; and/or (xii) cosmetic damages (e.g. scratches).

Additionally, this Limited Warranty does not cover and Varjo is not responsible for damage to the Varjo Product or loss of the Varjo Product resulting from normal wear and tear and normal depletion of consumable parts.

Finally, this Limited Warranty does not include any specific guarantees that the Varjo Product will be error-free or regarding uptime or continued availability, data security features of software or online accounts, or that any software, firmware or online sites will function uninterrupted or error-free. This Limited Warranty is void if the Varjo Product is returned with removed, damaged or tampered labels or any alterations (including the unauthorized removal of any component or external cover). [This Limited Warranty does not cover

data loss; it is Your responsibility to back up Your data, electronically or physically, on a regular basis if you wish to retain Your data. Any damages or costs related to data recovery, removal and installation are not recoverable under this Limited Warranty.]

## 5. Limitation of Liability

TO THE MAXIMUM EXTENT PERMITTED BY APPLICABLE LAW, NEITHER VARJO NOR ITS SUPPLIERS SHALL BE RESPONSIBLE FOR ANY INDIRECT, INCIDENTAL, CONSEQUENTIAL, PUNITIVE OR SPECIAL DAMAGES, INCLUDING BUT NOT LIMITED TO LOST PROFITS OR COMMERCIAL LOSS, BUSINESS INTERRUPTION, LOSS OF BUSINESS INFORMATION, LOSS OF DATA, LOSS OF PRIVACY, LOSS OF CONFIDENTIALITY, COST OF ANY REPLACEMENT GOODS OR SUBSTITUTE EQUIPMENT OR LOSS OF USE WHILE THE VARJO PRODUCT IS BEING REPLACED OR REPAIRED. TO THE MAXIMUM EXTENT PERMITTED BY APPLICABLE LAW, THE ENTIRE LIABILITY OF VARJO AND ITS SUPPLIERS UNDER THIS LIMITED WARRANTY SHALL BE LIMITED TO THE AMOUNT ACTUALLY PAID BY YOU FOR THE VARJO PRODUCT. THESE EXCLUSIONS APPLY EVEN IF A REMEDY FAILS OF ITS ESSENTIAL PURPOSE OR VARJO HAS BEEN ADVISED OF THE POSSIBILITY OF THESE DAMAGES, FOR ANY CLAIM ARISING FROM OR RELATED TO THIS LIMITED WARRANTY, REGARDLESS OF THE FORM OF ACTION, WHETHER IN CONTRACT, TORT (INCLUDING NEGLIGENCE), STRICT PRODUCT LIABILITY OR ANY OTHER CAUSE OF ACTION OR LEGAL OR EQUITABLE THEORY. Some states and countries do not allow the exclusion or limitation of incidental or consequential damages, so limitations or exclusions in this Limited Warranty may not apply to you.

No Varjo employee or representative or its affiliates or any third party is authorized to make any modification, extension or addition to the Limited Business Warranty or any part of these Terms.

## 6. General provisions

6.1 This Limited Warranty shall be subject to Finnish law, excluding its choice of law provisions. The UN Convention on Contracts for the International Sale of Goods shall not apply. Any dispute, controversy or claim arising out of this Limited Warranty shall be finally settled by arbitration in accordance with the Arbitration Rules of the Finland Chamber of Commerce. Seat of arbitration shall be Helsinki. The language of the arbitration shall be English.

6.2 If any provision of this Limited Warranty is found to be illegal, invalid, or unenforceable under the laws of any jurisdiction, this will not affect the legality, validity, or enforceability of any other provision of the Limited Warranty.



**Visit [varjo.com/start](https://varjo.com/start) for more information  
and updates to these instructions.**