



Microphone

BY-M1LV-U-RX, BY-M1LV-D-RX
BY-M1LVS-U-RX, BY-M1LVS-D-RX
SKM-S1-RXD, SKM-S1-RXU
SKM-S2-RXD, SKM-S2-RXU
MIC-L1-RXD, MIC-L1-RXU
MIC-L2-RXD, MIC-L2-RXU

User Manual
用户手册



General Introduction

Thanks for choosing BOYA!

The BOYA BY-M1LV is an incredibly lightweight, ultracompact and easy-to-use 2.4Ghz wireless microphone system for mobile devices, delivering detailed, exceptional-quality sound.

The BY-M1LV-U-RX receiver features a USB-C output, allowing it to work with Android phones, tablets and other devices with a USB-C port.

The BY-M1LV-TX clip-on transmitter has a high-quality built-in mic. It is small and light enough to clip to shirts and clothing. With gain control, headphone volume control and mute function, you are in total control of your sound.

The BOYA BY-M1LV system provides a great solution for live streaming, content creation, mobile journalism, and more.

Available Kits

Model	In the box
BY-M1LV-D	1 × BY-M1LV-D-RX
	1 × BY-M1LV-TX
BY-M1LV-U	1 × BY-M1LV-U-RX
	1 × BY-M1LV-TX

Product Structure

BY-M1LV-TX: Clip-on Transmitter with Built-in Microphone

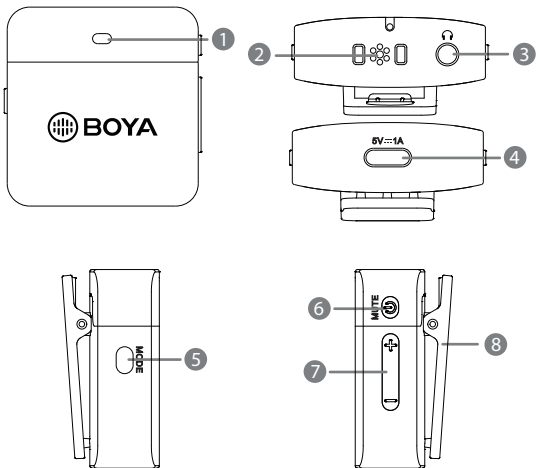

1. Status indicator

Mode	Indicator
Unpaired	Flashing blue light
Pairing	Blue and red lights flash alternately
Paired Successfully	Slow flashing blue light
Mute ON	Solid green light
Microphone Monitor ON (Supports Direct & Playback Monitoring)	Slow flashing green light
Microphone Monitor OFF (Only Supports Playback Monitoring)	Green light off
Low Battery	Flashing red light
Charging	Solid red light
Fully Charged	Light off

2. Built-in microphone

3. 3.5mm headphone jack

- Connect headphones for audio monitoring.

4. USB-C charging port

5. Mode button

Function	Operation
Gain adjustment	Short press the button to adjust mic gain. (There are 3 steps for gain setting)
Enable microphone monitor function	Double-click the button to enter microphone monitor mode. Then, press +/-button to adjust headphone volume. Double-click the button again to exit microphone monitor mode.

6. Power/Mute button

Function	Operation
Power ON/OFF	Press and hold for 3 seconds
Mute ON/OFF	Short press
Pairing	Double-click

7. Volume control (+-button)

- Press the +/- button to adjust headphone volume.

8. Belt clip

Voice Prompt

Power ON	"Power ON"
Power OFF	"Power OFF"
Connected	"Bluetooth Connected"
Disconnected	"Bluetooth Disconnected"
Class One (Gain Setting)	"Class One"
Class Two (Gain Setting)	"Class Two"
Class Three (Gain Setting)	"Class Three"
Microphone Monitor Function Enabled	"Microphone Monitor ON"
Microphone Monitor Function Disabled	"Microphone Monitor OFF"
Low Battery	"Battery Low"
Mute OFF	"Microphone ON"
Mute ON	"Microphone OFF"

BY-M1LV-U-RX: Compact Receiver with USB-C Connector

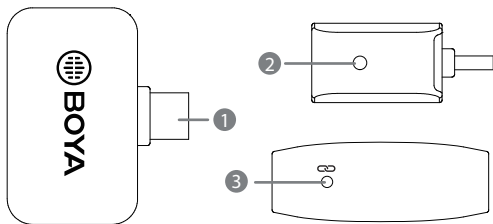

1. USB-C Connector

- It can be connected to an Android smartphone, tablet or other USB-C devices.

2. Pairing Indicator

Mode	Indicator
Unpaired	Flashing blue light
Pairing	Quick flashing blue light
Paired Successfully	Slow flashing blue light

3. Pair Pinhole

Operation Guide

1. Press and hold the power button for 3 seconds to turn on the transmitter.
2. Plug the BY-M1LV-D-RX into an iOS device or the BY-M1LV-U-RX into a USB-C device.

3. Transmitter and receiver pairing

Before leaving factory, the system is pre-paired. Therefore, the connection will be established once they are powered on. If they are disconnected, please follow the steps below:

- ① Double-click the power button of transmitter. The indicator flashes blue and red alternately.
 - ② When the transmitter indicator flashes blue and red alternately, insert the supplied pairing pin into the small pinhole on the receiver. The indicator of receiver flashes blue rapidly.
 - ③ Transmitter and receiver will be paired within 10 seconds. Indicators of both will flash blue slowly.
4. You are ready to record.



Note:

Due to 2.4GHz wireless frequency, signal can be easily attenuated. Please try to avoid obstacles, such as walls and buildings, and avoid close proximity to devices with 2.4GHz signal, such as high-power wifi antennas, smartphones with wifi in use, radios, etc.

Connection Example

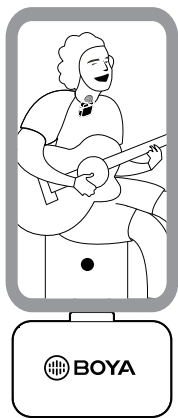

Note:

Compatible with TRS/TRRS headphones (**not included**)

Specifications

BY-M1LV-TX

Transmission Type	2.4GHz
Modulation	GFSK
Operating Range	Up to 328' (100m) (without obstacles)
RF Output Power	-3.190dBm
Microphone Polar Pattern	Built-in Microphone: Omnidirectional
Frequency Response	50Hz-8.5KHz
SNR	> 70dB
Maximum SPL	Built-in Microphone: 110dB SPL
Sensitivity	Built-in Microphone: -39dB±2dB (0dB=1V/Pa@1kHz)
Power Requirement	Built-in Li-ion Battery or USB-C DC 5V
Antenna	PIFA Antenna
Battery Life	Approx. 6 hours
Audio Output	3.5mm Jack
Weight	Approx. 18g
Dimensions	40×38.2×14mm
Operating Temperature	-10°C to 50°C
Storage Temperature	-20°C to 55°C

BY-M1LV-U-RX

Transmission Type	2.4GHz
Modulation	GFSK
Operating Range	Up to 328' (100m) (without obstacles)
RF Output Power	2.014dBm
Audio Output	USB-C Connector
Power Requirements	Supplied by USB-C Devices
Antenna	PIFA Antenna
Noise Reduction	Yes
Weight	Approx. 10g
Dimensions	23×38.2×14mm
Operating Temperature	-10°C to 50°C
Storage Temperature	-20°C to 55°C

Packing List

BY-M1LV-U (BY-M1LV-TX+ BY-M1LV-U-RX)

1 × BY-M1LV-TX Transmitter

1 × BY-M1LV-U-RX Receiver

1 × USB-C Charging Cable

1 × Fur Windshield

1 × Pairing Pin

FCC Warning

This device complies with part 15 of the FCC Rules. Operation is subject to the following two conditions: (1) This device may not cause harmful interference, and (2) this device must accept any interference received, including interference that may cause undesired operation.

Any Changes or modifications not expressly approved by the party responsible for compliance could void the user's authority to operate the equipment.

This equipment has been tested and found to comply with the limits for a Class B digital device, pursuant to part 15 of the FCC Rules. These limits are designed to provide reasonable protection against harmful interference in a residential installation.

This equipment generates uses and can radiate radio frequency energy and, if not installed and used in accordance with the instructions, may cause harmful interference to radio communications. However, there is no guarantee that interference will not occur in a particular installation. If this equipment does cause harmful interference to radio or television reception, which can be determined by turning the equipment off and on, the user is encouraged to try to correct the interference by one or more of the following measures:

- Reorient or relocate the receiving antenna.
- Increase the separation between the equipment and receiver.
- Connect the equipment into an outlet on a circuit different from that to which the receiver is connected.
- Consult the dealer or an experienced radio/TV technician for help.

The device has been evaluated to meet general RF exposure requirement. The device can be used in portable exposure condition without restriction.