

INSTALLATION AND OPERATING INSTRUCTIONS

Ride on car

WARNING:

The toy is to be assembled by an adult.
This toy is unsuitable for children under
3 years due to its maximum speed.

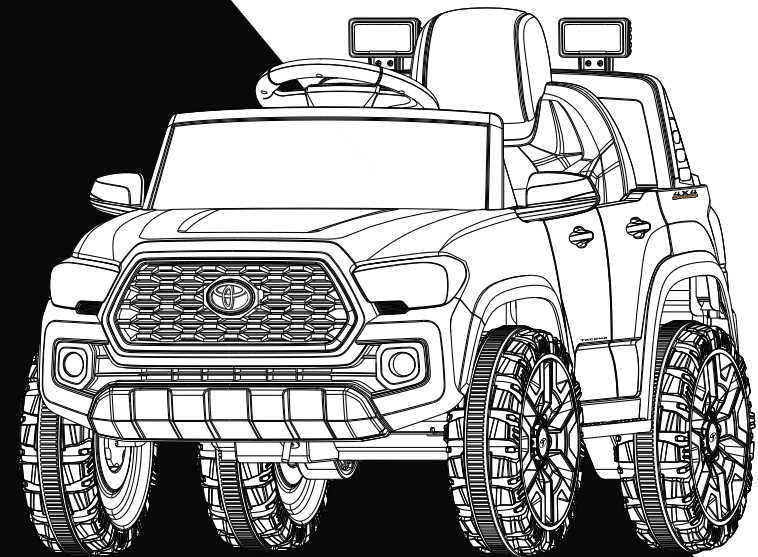

Executive standard:
En71 and En62115
ASTM F963-17

Photos are for reference ONLY.

INSTALLATION INSTRUCTION

The illustrations in this instruction are used for easier understanding of the operation method of the product and the product structure. Please note there may be differences between the pictures and the physical item.

In order to improve the quality, we may change part of the structure and appearance of the product without an advance notice.

! Please read the instructions carefully before use, it will tell you the right operation method and installation steps. Incorrect operation may damage the product, or even hurt your child. Please keep this instruction ready and easy to find.

Preparation before installation: Power-on

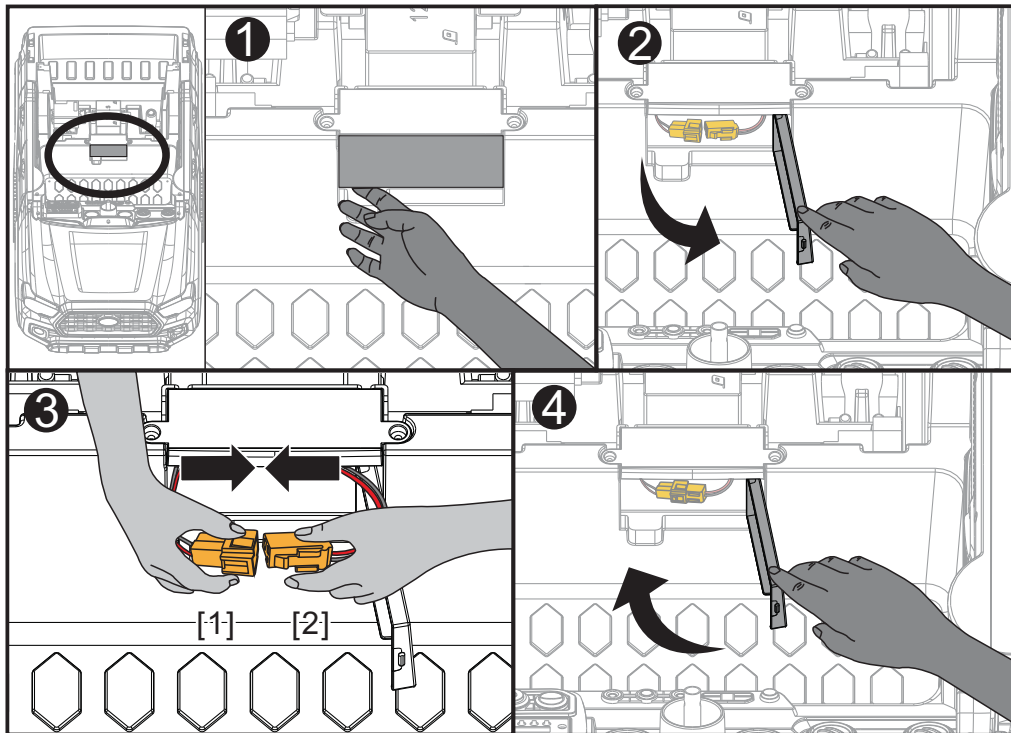

1 & 2: Please find and open the charging hole cover as shown in figure.

3. Connect the terminal [1] and [2].

4. Close the charging hole cover.

1 Safety

! WARNING!

The owner's manual contains assembly, use and maintenance instructions. The vehicle must be assembled by an adult who has read and understood the instructions in this manual. Keep the packaging away from children and dispose of all packaging before use.

Note: For best performance use on flat, hard surfaces.

The following safety hazards may result in serious injury or death to the user of the vehicle:

- This product contains small parts that are for adult assembly only. Keep small children away when assembling. Remove and dispose of all protective material and poly bags before assembly. Be sure to remove all packaging materials and parts from underneath the vehicle body.
 - Battery posts, terminals and related accessories contain lead and lead compounds (acids) chemicals known to the state of California to cause cancer, reproductive harm, and are toxic and corrosive. Never open the battery.
 - Body parts such as hands, legs, hair and clothing can get caught in moving parts. Never place a body part near a moving part or wear loose clothing while using the vehicle. Always wear shoes when using the vehicle.
 - This toy does not have brakes or any braking capability. Do not leave a child unattended while using this toy or allow use of this toy in any location that requires braking capability, as this could result in a roll away or loss of control, which may cause serious injury or death.
 - Use of this vehicle near streets, motor vehicles, steps, bodies of water, sloped surfaces, hills, wet areas, flammable vapors, in alleys, at night, or in the dark could result in an unexpected accident.
 - Using the vehicle in unsafe conditions such as snow, rain, loose dirt, mud, sand or fine gravel may result in unexpected action such as tip over and skidding, and damage to the electrical system and battery.
 - Do not use the vehicle in an unsafe manner. Unsafe manner include but are not limited to:
 - a. Pulling the vehicle with another vehicle or similar device
 - b. Allowing more than one rider
 - c. Pushing the user from the back
 - d. Traveling at an unsafe speed
 - The remote control is not a toy. It is for the adult use only, and should not be used by a child. A close adult supervision is always required. Reception range may change significantly with weather, battery, and other environmental conditions.
- Always use common sense and safe practices when using the vehicle.

BATTERY WARNINGS

⚠ WARNING!

The following safety hazards may result in serious injury or death to the user of the vehicle:



- Use of a battery or charger other than the supplied 12V rechargeable battery and charger may cause a fire or explosion. Only use the supplied 12V rechargeable battery and charger with the vehicle.
- Using the 12V rechargeable battery and charger for any other product may result in overheating, fire or explosion. Never use the 12V rechargeable battery and charger with another product.



- Explosive gases are created during charging. Charge the battery in a well ventilated area. Do not charge the battery near heat or flammable materials.
- Contact between the positive and negative terminals may result in fire or explosion. Avoid direct contact between the terminals. Picking up the battery by the wires or charger can cause damage to the battery and may result in a fire. Always pick up the battery by the case or handles.



- Liquids on the battery may cause fire or electric shock. Always keep all liquids away from the battery and keep the battery dry.
- Contact or exposure to battery leakage (lead acid) may cause serious injury. If contact or exposure occurs immediately call your physician. If the chemical is on the skin or in the eyes, flush with cool water for 15 minutes. If the chemical was swallowed, immediately give the person water or milk. Do not give water or milk if the patient is vomiting or has a decreased level of alertness. Do not induce vomiting.

- Battery posts, terminals and related accessories contain lead and lead compounds (acid), chemicals known to the State of California to cause cancer, reproductive harm and are toxic and corrosive. Never open the battery.



- Tampering or modifying the electric circuit system may cause a shock, fire or explosion and permanently damage the system. Exposed wiring, circuitry in the charger may cause electric shock. Always keep the charger housing closed.

USER REQUIREMENTS AND WARNINGS

Age	37-96 months
Max Weight	(30kgs)

Before using the vehicle the child should understand the vehicle controls and safety issues. They must also demonstrate the capability to handle the vehicle and operate its controls. It is the responsibility of the adult to educate the child and supervise the vehicles use. Read the following safety warnings to any child using the vehicle before riding.

⚠ WARNING!

- Never leave child unattended. Always supervise the child.
- Always sit in the seat when using the vehicle.
- Keep your hands, hair and clothes away from moving parts.
- Always wear shoes when using the vehicle.
- Only one rider is allowed on the vehicle at a time.
- Children under 3 years of age cannot use the vehicle.
- Only drive on level ground.
- Do not go near swimming pools or other bodies of water, drop-offs or up and down steep inclines.
- Do not drive the vehicle into loose dirt, mud, sand or fine gravel.
- Do not drive the vehicle on streets or near cars.
- Protective equipment should be worn. Not to be used in traffic.

CARE WARNINGS

⚠ WARNING!

- Park the vehicle indoors or cover it with a tarp to protect it from wet weather.
- Do not leave the vehicle in the sun for long periods of time or fading may occur. Store in shade or cover with tarp.
- Do not wash the vehicle with a hose.
- Do not wash the vehicle with soap and water.
- Pay attention while driving the vehicle, avoid falls or collisions causing injury to the user or third parties.
- Please check the component parts before using, and make regularly examine the transformers or battery chargers for in the event of any damage on the cord, plug, enclosure and other parts, the vehicle shall not be used until the damage has been repaired, to avoid an accident.

RE-CHARGE INTERVAL AND TIME Important!

- Damage to the battery may occur if it is allowed to drain completely. Do not allow the battery to drain completely.
- Check the battery and charger (supply cord, connector) for wear and damage before charging. Do not charge the battery if damage has occurred.
- On average you will need to charge the battery between 8 and 12 hours.
- Do not charge the battery for more than 20 hours. Failure to charge the battery as directed could cause permanent damage to the battery and void the warranty.
- Only an adult who has read and understood the safety warnings should handle, charge and recharge the battery.

Specification







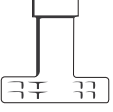

Name	specification
Battery	12V 4.5AH(6-FM-4.5 (AH) * 1 / 12V 7AH(6-FM-7 (AH) * 1
Motor	Motor: DC 12V Steering motor: DC 12V
Suitable age	37-96 months
Max weight	30KG
Body size	1010*620*620MM
Speed	2-4KM/h
Hours of use	charging 8-12 hours, using 1 to 2 hours
Charger	Input: 100V~240V AC Output: DC 12V500MA/ DC 12V1000MA
Mainmaterial	PP(polypropylene) and iron

*The above parameters contain optional features, specific parameters please refer to our samples.

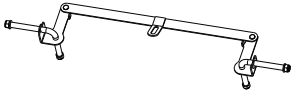
Preparation work:

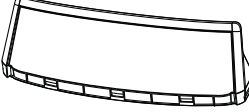
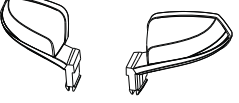
Put the car upside down on a soft cloth or smooth plane firstly (Can't be directly placed on the surface of the cement, etc., which will scratch the surface of the plastic), then take off the cardboard, foam, nylon cable ties.

Parts List

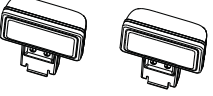
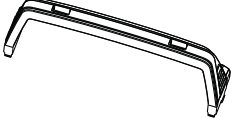
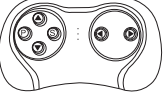
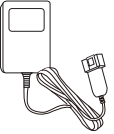
NO.	QTY	PICTURE	NO.	QTY	PICTURE
①	1	 A(Instruction Book)	②	2	 B(M8 spanner)
③	4	 C(Wheel)	④	4	 D (Wheel Cover)
⑤	1	 E(Front axle)	⑥	1	 F(Steering wheel)
⑦	1	 G(Wind deflector)	⑧	1 set	 H(Rearview mirror)
⑨	1	 I(seat)	⑩	4	 J (self-tapping screw)
⑪	1	 K(Backrest)	⑫	2	 L(Rear lamp)
⑬	1	 M(Tail frame lamp holder)	⑭	1 (optional)	 N (Remote control)
⑮	1	 O(Charger)			

*Photos are for reference ONLY.

Installation Steps

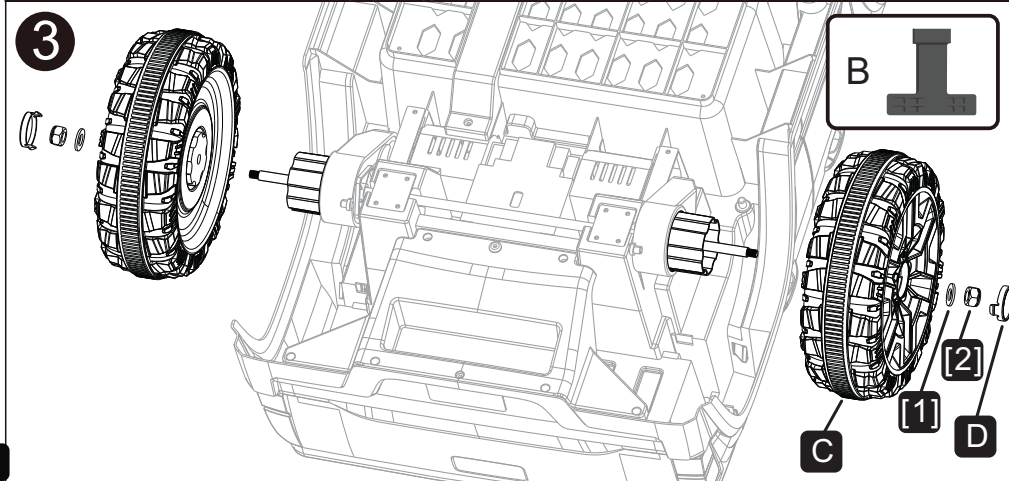
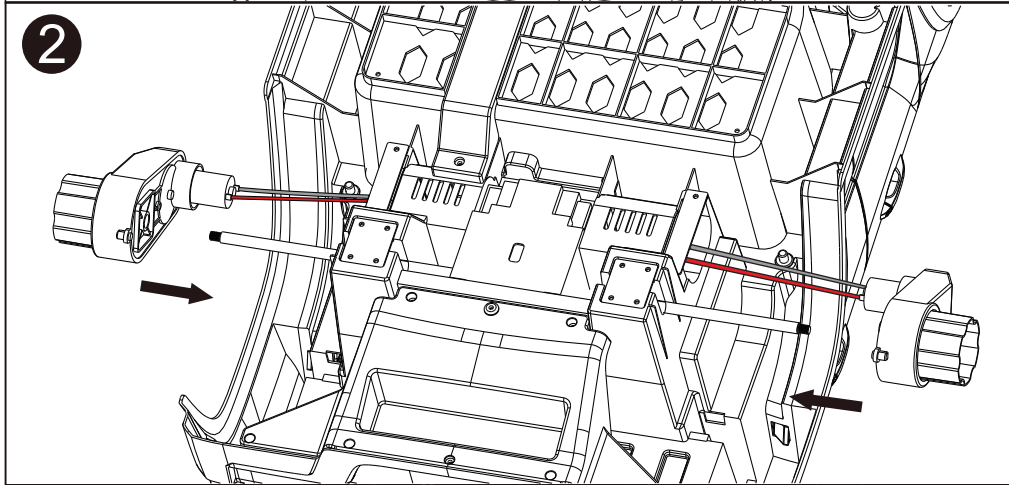
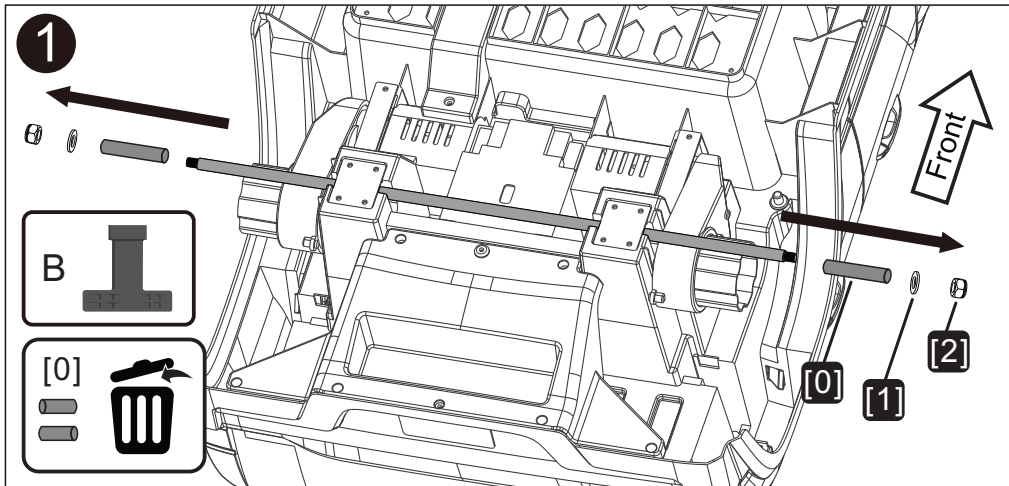

Step 1: Install rear wheel.

1. Remove the nut and washer from the Rear axle with B(M8 spanner). The paper tube [0] needs to be thrown into the trash can.
2. Cut off the nylon cable ties on the motors firstly, then install the motors to rear axle.
3. Install [C] (wheel), Replace [1] (washer), [2] (M8 nut) on A (rear axle), and install D (wheel cover) on C (wheel).

