

Direction for use

Introduction

This controller is used for electric kid's cars, including a remote control and a controller (for receiving). It uses 2.4G wireless remote control. The controller controls two motors to rotate. The remote control uses 3V battery to supply power. The receiver uses 12V battery to supply power. Product ship with no battery.

1. The installation and replacement of the batteries in the remote control:

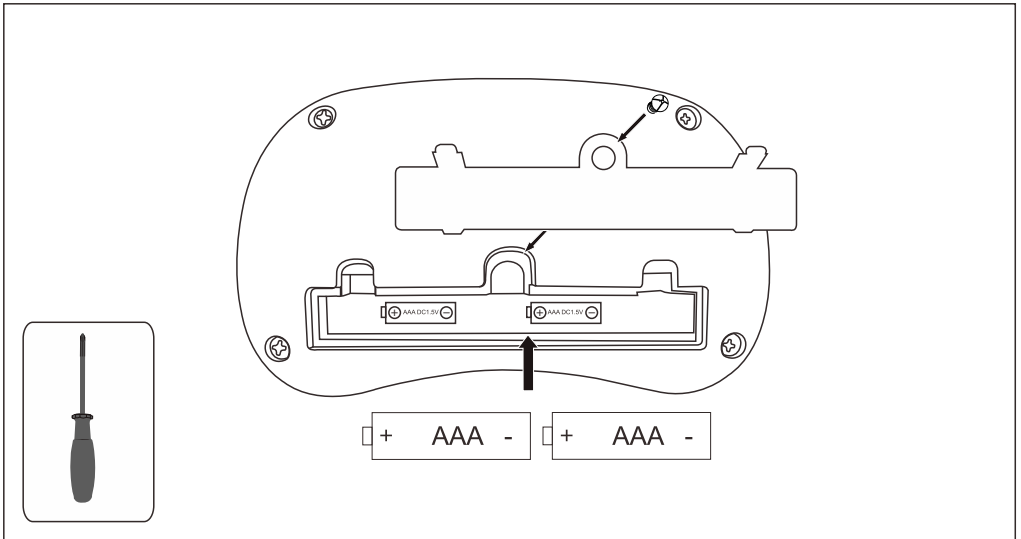

Use a screwdriver to remove the battery cover of the remote control, insert two AAA 1.5V dry batteries in correct polarity. Close the battery cover and fix it with the screw. (Battery replacement also according to the above steps)

! WARNING!

- 1.All batteries should be inserted in the correct polarity.
- 2.Non-rechargeable battery cannot be recharged
- 3.Take out and properly deal with the dead battery. To avoid injury, please keep kids away from the battery.
- 4.The direct contact between the positive and negative terminals may result in fire or explosion. Avoid direct connect between the terminals.
- 5.Do not mix old and new batteries. DO not mix alkaline, standard(carbon-zinc),or rechargeable(nickel-cadmium) batteries.
- 6.Only an adult who has read and understood the safety warnings can recharge the battery.

Instructions:

Connect the controller to the electric kid's car with wire and turn on the car and controller at the same time.

Coding the controller and receiver when control with the remote controller. When the remote controller first turns on, the top light flashes slowly and then turns on the receiver. When the light long bright, it means coding finishes and you can turn on the car.

There are 6 buttons on the remote controller: forward, backward, left, right, Speed Conversion, stop. The power button is used as the power supply when the remote controller is stand-by. When the remote control is working.

2. Matching the frequency of car and remote control

1. Turn off the Power Switch on the car.
2. Remove the battery cover on the Remote Control and put in 2 AAA battery, the three LED indicators will flash.
3. Turn on the Power Switch on the car, when the LED indicators stop flashing and 2 of them are on, matching succeeds.
4. Once the matching is made, there is no need to match code again only if the battery is replaced.
5. The Remote Control will enter a sleep mode if not used for a long time and the LED indicators will be off. Press any buttons to wake up the Remote Control, and it can be used normally.

Button Description: ▲: forward ▼: reverse ◀: turn left ▶: turn right
S: Speed P: emergency brake, press it and the running function will fail, press again, it release.

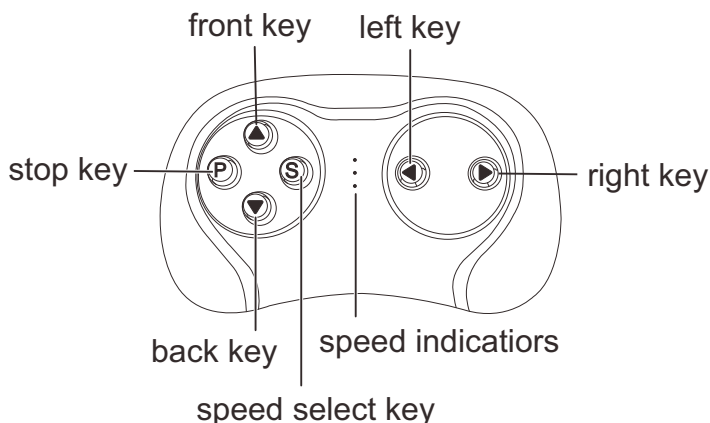

Remote control operating instruction

Remote control is priority (when the car is in Remote control, the remote control personnel can control the car forward and backward, high/Low speed, steering and other functions, the driver CAN NOT operate the car). Press the ▲ forward button, the car goes forward.

Press ▼ reverse button, the car goes reverse.

Press the P button to brake the car urgently. Press P button again to release the brake system. Press the turn left button, car turn left, Press the turn right button, car turn right,

The S button is speed button, one light on is low speed, two lights on for intermediate speed, three lights on for high speed.

WARNING!

Please take attention that changes or modification not expressly approved by the party responsible for compliance could void the user's authority to operate the equipment.

This device complies with Part 15 of the FCC Rules. Operation is subject to the following two conditions:(1) This device may not cause harmful interference,and (2) this device must accept any interference received, including interference that may cause undesired operation.