

TEST REPORT

Application No.: SHEM2010008587CR
FCC ID: 2ARLM-CST-1A
Applicant: Pinghu City Cang Sheng Plastic Factory
Address of Applicant: group 22, zhonghua village, xincang town, pinghu city, Zhejiang Province, 314200 China
Manufacturer: Pinghu City Cang Sheng Plastic Factory
Address of Manufacturer: group 22, zhonghua village, xincang town, pinghu city, Zhejiang Province, 314200 China
Factory: Pinghu City Cang Sheng Plastic Factory
Address of Factory: group 22, zhonghua village, xincang town, pinghu city, Zhejiang Province, 314200 China
Equipment Under Test (EUT):
EUT Name: REMOTE CONTROL
Model No.: CST-1A
Standard(s) : 47 CFR Part 15, Subpart C 15.249
Date of Receipt: 2020-10-15
Date of Test: 2020-10-17 to 2020-10-28
Date of Issue: 2020-10-29

Test Result:	Pass*
---------------------	--------------

* In the configuration tested, the EUT complied with the standards specified above.

Parlam Zhan

Parlam Zhan
E&E Section Manager

The manufacturer should ensure that all products in series production are in conformity with the product sample detailed in this report. If the product in this report is used in any configuration other than that detailed in the report, the manufacturer must ensure the new system complies with all relevant standards. Any mention of SGS International Electrical Approvals or testing done by SGS International Electrical Approvals in connection with, distribution or use of the product described in this report must be approved by SGS International Electrical Approvals in writing.



Unless otherwise agreed in writing, this document is issued by the Company subject to its General Conditions of Service printed overleaf, available on request or accessible at <http://www.sgs.com/en/Terms-and-Conditions.aspx> and, for electronic format documents, subject to Terms and Conditions for Electronic Documents at <http://www.sgs.com/en/Terms-and-Conditions/Terms-e-Document.aspx>. Attention is drawn to the limitation of liability, indemnification and jurisdiction issues defined therein. Any holder of this document is advised that information contained hereon reflects the Company's findings at the time of its intervention only and within the limits of Client's instructions, if any. The Company's sole responsibility is to its Client and this document does not exonerate parties to a transaction from exercising all their rights and obligations under the transaction documents. This document cannot be reproduced except in full, without prior written approval of the Company. Any unauthorized alteration, forgery or falsification of the content or appearance of this document is unlawful and offenders may be prosecuted to the fullest extent of the law. Unless otherwise stated the results shown in this test report refer only to the sample(s) tested and such sample(s) are retained for 30 days only.
Attention: To check the authenticity of testing /inspection report & certificate, please contact us at telephone: (86-755) 8307 1443, or email: CN.Doccheck@sgs.com

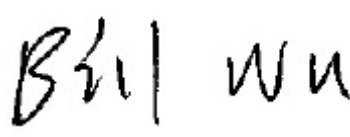
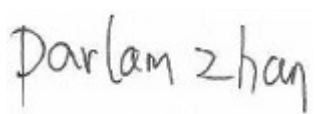

Revision Record			
Version	Description	Date	Remark
00	Original	2020-10-29	/

Authorized for issue by:			
			
		<hr/> Bill Wu / Project Engineer	
			
		<hr/> Parlam Zhan / Reviewer	

2 Test Summary

Radio Spectrum Technical Requirement				
Item	Standard	Method	Requirement	Result
Antenna Requirement	47 CFR Part 15, Subpart C 15.249	N/A	47 CFR Part 15, Subpart C 15.203	Pass

Radio Spectrum Matter Part				
Item	Standard	Method	Requirement	Result
20dB Bandwidth	47 CFR Part 15, Subpart C 15.249	ANSI C63.10 (2013) Section 6.9	47 CFR Part 15, Subpart C 15.215	Pass
Field Strength of the Fundamental Signal (15.249(a))	47 CFR Part 15, Subpart C 15.249	ANSI C63.10 (2013) Section 6.5&6.6	47 CFR Part 15, Subpart C 15.249(a)	Pass
Restricted Band Around Fundamental Frequency	47 CFR Part 15, Subpart C 15.249	ANSI C63.10 (2013) Section 6.4&6.5&6.6	47 CFR Part 15, Subpart C 15.205 & 15.249(d) & 15.209	Pass
Radiated Emissions	47 CFR Part 15, Subpart C 15.249	ANSI C63.10 (2013) Section 6.4&6.5&6.6	47 CFR Part 15, Subpart C 15.209 & 15.249 (a),(d)	Pass



3 Contents

	Page
1 COVER PAGE.....	1
2 TEST SUMMARY	3
3 CONTENTS.....	4
4 GENERAL INFORMATION.....	5
4.1 DETAILS OF E.U.T.	5
4.2 DESCRIPTION OF SUPPORT UNITS	5
4.3 MEASUREMENT UNCERTAINTY.....	5
4.4 TEST LOCATION.....	6
4.5 TEST FACILITY.....	6
4.6 DEVIATION FROM STANDARDS	6
4.7 ABNORMALITIES FROM STANDARD CONDITIONS.....	6
5 EQUIPMENT LIST.....	7
6 RADIO SPECTRUM TECHNICAL REQUIREMENT.....	8
6.1 ANTENNA REQUIREMENT	8
7 RADIO SPECTRUM MATTER TEST RESULTS.....	9
7.1 20DB BANDWIDTH	9
7.2 FIELD STRENGTH OF THE FUNDAMENTAL SIGNAL (15.249(A)).....	12
7.3 RESTRICTED BAND AROUND FUNDAMENTAL FREQUENCY.....	15
7.4 RADIATED EMISSIONS	20
8 TEST SETUP PHOTOGRAPHS	28
9 EUT CONSTRUCTIONAL DETAILS.....	28

4 General Information

4.1 Details of E.U.T.

Power supply:	DC 3V By 2*AAA size batteries
Test voltage:	DC 3V
Antenna Type	Omnidirectional Antenna
Antenna Gain	1.6dBi
Channel Spacing:	2MHz
Modulation Type:	GFSK
Number of Channels:	40
Operation Frequency:	2402-2480MHz

4.2 Description of Support Units

The EUT has been tested as an independent unit.

4.3 Measurement Uncertainty

No.	Item	Measurement Uncertainty
1	Radio Frequency	8.4×10^{-8}
2	Timeout	2s
3	Duty Cycle	0.37%
4	Occupied Bandwidth	3%
5	RF Conducted Power	0.6dB
6	RF Power Density	2.9dB
7	Conducted Spurious Emissions	0.75dB
8	RF Radiated Power	5.1dB (Below 1GHz)
		4.9dB (Above 1GHz)
9	Radiated Spurious Emission Test	4.2dB (Below 30MHz)
		4.5dB (30MHz-1GHz)
		5.1dB (1GHz-18GHz)
		5.4dB (Above 18GHz)
10	Temperature Test	1°C
11	Humidity Test	3%
12	Supply Voltages	1.5%
13	Time	3%

Note: The measurement uncertainty represents an expanded uncertainty expressed at approximately the 95% confidence level using a coverage factor of k=2.

4.4 Test Location

All tests were performed at:

SGS-CSTC Standards Technical Services Co., Ltd. Shanghai Branch

588 West Jindu Road, Xinqiao, Songjiang, 201612 Shanghai, China

Tel: +86 21 6191 5666 Fax: +86 21 6191 5678

No tests were sub-contracted.

4.5 Test Facility

The test facility is recognized, certified, or accredited by the following organizations:

- **CNAS (No. CNAS L0599)**

CNAS has accredited SGS-CSTC Standards Technical Services (Shanghai) Co., Ltd. to ISO/IEC 17025:2017 General Requirements for the Competence of Testing and Calibration Laboratories (CNAS-CL01 Accreditation Criteria for the Competence of Testing and Calibration Laboratories) for the competence in the field of testing.

- **NVLAP (LAB CODE: 201034-0)**

SGS-CSTC Standards Technical Services (Shanghai) Co., Ltd. is accredited by the National Voluntary Laboratory Accreditation Program (NVLAP).

- **FCC (Designation Number: CN5033)**

SGS-CSTC Standards Technical Services (Shanghai) Co., Ltd. has been recognized as an accredited testing laboratory.

- **ISED (CAB Identifier: CN0020)**

SGS-CSTC Standards Technical Services (Shanghai) Co., Ltd. EMC Laboratory has been recognized by Innovation, Science and Economic Development Canada (ISED) as an accredited testing laboratory.

- **VCCI (Member No.: 3061)**

The 3m Semi-anechoic chamber and Shielded Room of SGS-CSTC Standards Technical Services (Shanghai) Co., Ltd. has been registered in accordance with the Regulations for Voluntary Control Measures with Registration No.: R-13868, C-14336, T-12221, G-10830 respectively.

4.6 Deviation from Standards

None

4.7 Abnormalities from Standard Conditions

None

5 Equipment List

Equipment	Manufacturer	Model No	Inventory No	Cal Date	Cal Due Date
RF Conducted Test					
Spectrum Analyzer	R&S	FSP-30	SHEM002-1	2019-12-20	2020-12-19
Spectrum Analyzer	Agilent	N9020A	SHEM181-1	2020-08-13	2021-08-12
Signal Generator	R&S	SMR20	SHEM006-1	2020-08-13	2021-08-12
Signal Generator	Agilent	N5182A	SHEM182-1	2020-08-13	2021-08-12
Communication Tester	R&S	CMW270	SHEM183-1	2020-08-13	2021-08-12
Switcher	Tonscend	JS0806	SHEM184-1	2020-08-13	2021-08-12
Power Sensor	Keysight	U2021XA * 4	SHEM184-1	2020-08-13	2021-08-12
Splitter	Anritsu	MA1612A	SHEM185-1	/	/
Coupler	e-meca	803-S-1	SHEM186-1	/	/
High-low Temp Cabinet	Suzhou Zhihe	TL-40	SHEM087-1	2018-09-25	2021-09-24
AC Power Stabilizer	APC	KDF-31020T-V0-F0	SHEM216-1	2019-12-20	2020-12-19
DC Power Supply	MCH	MCH-303A	SHEM210-1	2019-12-20	2020-12-19
Conducted test Cable	/	RF01~RF04	/	2019-12-20	2020-12-19
RF Radiated Test					
EMI test Receiver	R&S	ESU40	SHEM051-1	2019-12-20	2020-12-19
Spectrum Analyzer	R&S	FSP-30	SHEM002-1	2019-12-20	2020-12-19
Loop Antenna (9kHz-30MHz)	Schwarzbeck	FMZB1519	SHEM135-1	2019-12-20	2020-12-19
Antenna (25MHz-2GHz)	Schwarzbeck	VULB9168	SHEM048-1	2019-10-14	2021-10-13
Antenna (25MHz-2GHz)	Schwarzbeck	VULB9168	SHEM202-1	2019-04-30	2021-04-29
Horn Antenna (1-18GHz)	Schwarzbeck	HF906	SHEM009-1	2017-10-24	2020-10-23
Horn Antenna (1-18GHz)	Schwarzbeck	HF906	SHEM009-1	2020-10-23	2021-10-22
Horn Antenna (1-18GHz)	Schwarzbeck	BBHA9120D	SHEM050-1	2019-10-14	2021-10-13
Horn Antenna (14-40GHz)	Schwarzbeck	BBHA 9170	SHEM049-1	2017-10-31	2020-10-30
Pre-amplifier (9KHz-2GHz)	CLAVIIO	BDLNA-0001	SHEM164-1	2020-08-13	2021-08-12
Pre-amplifier (1-18GHz)	CLAVIIO	BDLNA-0118	SHEM050-2	2020-08-13	2021-08-12
High-amplifier (14-40GHz)	Schwarzbeck	10001	SHEM049-2	2019-12-20	2020-12-19
Signal Generator	R&S	SMR40	SHEM058-1	2020-08-13	2021-08-12
Band Filter	LORCH	9BRX-875/X150	SHEM156-1	/	/
Band Filter	LORCH	13BRX-1950/X500	SHEM083-2	/	/
Band Filter	LORCH	5BRX-2400/X200	SHEM155-1	/	/
Band Filter	LORCH	5BRX-5500/X1000	SHEM157-2	/	/
High pass Filter	Wainwright	WHK3.0/18G	SHEM157-1	/	/
High pass Filter	Wainwright	WHKS1700	SHEM157-3	/	/
Semi/Fully Anechoic	ST	11*6*6M	SHEM078-2	2020-05-25	2023-05-24
RE test Cable	/	RE01, RE02, RE06	/	2019-12-20	2020-12-19

6 Radio Spectrum Technical Requirement

6.1 Antenna Requirement

6.1.1 Test Requirement:

47 CFR Part 15, Subpart C 15.203

Limit:

15.203 requirement:

An intentional radiator shall be designed to ensure that no antenna other than that furnished by the responsible party shall be used with the device. The use of a permanently attached antenna or of an antenna that uses a unique coupling to the intentional radiator, the manufacturer may design the unit so that a broken antenna can be replaced by the user, but the use of a standard antenna jack or electrical connector is prohibited.

6.1.2 Conclusion

Standard Requirement:

An intentional radiator shall be designed to ensure that no antenna other than that furnished by the responsible party shall be used with the device. The use of a permanently attached antenna or of an antenna that uses a unique coupling to the intentional radiator, the manufacturer may design the unit so that a broken antenna can be replaced by the user, but the use of a standard antenna jack or electrical connector is prohibited.

EUT Antenna:

The antenna is omnidirectional antenna and no consideration of replacement. The best case gain of the antenna is 1.6dBi.

Antenna location: Refer to Appendix (Internal Photos)

7 Radio Spectrum Matter Test Results

7.1 20dB Bandwidth

Test Requirement 47 CFR Part 15, Subpart C 15.215
Test Method: ANSI C63.10 (2013) Section 6.9
Limit: N/A

7.1.1 E.U.T. Operation

Operating Environment:

Temperature: 22 °C Humidity: 50 % RH Atmospheric Pressure: 1002 mbar

Test mode a:TX mode_Keep the EUT in transmitting with modulation mode.

7.1.2 Measurement Procedure and Data

Frequency (MHz)	Bandwidth (MHz)	Result
2402	1.08	PASS
2442	1.09	PASS
2480	1.10	PASS

Test plot as follows:

Channel: 2402MHz



Channel: 2442MHz



Channel: 2480MHz



7.2 Field Strength of the Fundamental Signal (15.249(a))

Test Requirement: 47 CFR Part 15, Subpart C 15.249(a)
Test Method: ANSI C63.10 (2013) Section 6.5&6.6
Limit:

Fundamental frequency(MHz)	Field strength of fundamental(millivolts/meter)	Field strength of harmonics(microvolts/meter)
902-928	50	500
2400-2483.5	50	500
5725-5875	50	500
24000-24250	250	2500

Remark: The frequencies above 1000MHz are based on average limits. However, the peak field strength of any emission shall not exceed the maximum permitted average limits specified above by more than 20 dB under any condition of modulation.

For fundamental frequency in "902-928MHz", the field strength of fundamental is based on Quasi-Peak.

Test Setup:

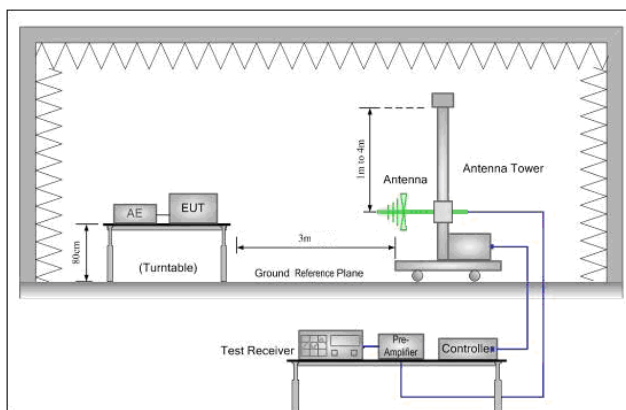

Figure 1. 30MHz to 1GHz

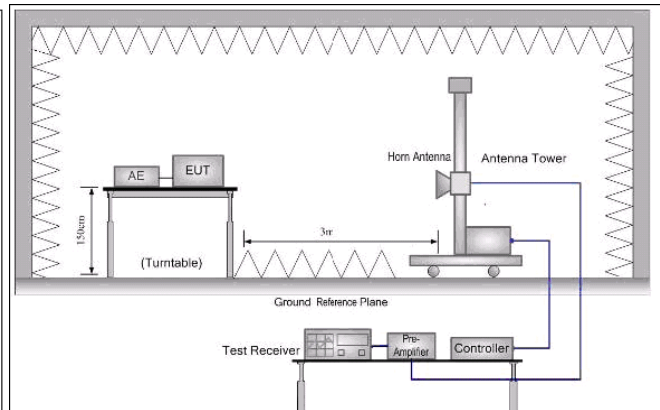

Figure 2. Above 1 GHz

7.2.1 E.U.T. Operation

Operating Environment:

Temperature: 22 °C Humidity: 50 % RH Atmospheric Pressure: 1002 mbar

Test mode a:TX mode_Keep the EUT in transmitting with modulation mode.

7.2.2 Measurement Procedure and Data

- a. For below 1GHz, the EUT was placed on the top of a rotating table 0.8 meters above the ground at a 3 or 10 meter semi-anechoic chamber. The table was rotated 360 degrees to determine the position of the highest radiation.
 - b. For above 1GHz, the EUT was placed on the top of a rotating table 1.5 meters above the ground at a 3 meter fully-anechoic chamber. The table was rotated 360 degrees to determine the position of the highest radiation.
 - c. The EUT was set 3 or 10 meters away from the interference-receiving antenna, which was mounted on the top of a variable-height antenna tower.
 - d. The antenna height is varied from one meter to four meters above the ground to determine the maximum value of the field strength. Both horizontal and vertical polarizations of the antenna are set to make the measurement.
 - e. For each suspected emission, the EUT was arranged to its worst case and then the antenna was tuned to heights from 1 meter to 4 meters (for the test frequency of below 30MHz, the antenna was tuned to heights 1 meter) and the rotatable table was turned from 0 degrees to 360 degrees to find the maximum reading.
 - f. The test-receiver system was set to Peak Detect Function and Specified Bandwidth with Maximum Hold Mode.
 - g. If the emission level of the EUT in peak mode was 10dB lower than the limit specified, then testing could be stopped and the peak values of the EUT would be reported. Otherwise the emissions that did not have 10dB margin would be re-tested one by one using peak, quasi-peak or average method as specified and then reported in a data sheet.
 - h. Test the EUT in the lowest channel, the middle channel, the Highest channel.
 - i. The radiation measurements are performed in X, Y, Z axis positioning for Transmitting mode, and found the X axis positioning which it is the worst case.
 - j. Repeat above procedures until all frequencies measured was complete.
- Remark: Level= Read Level+ Cable Loss+ Antenna Factor- Preamp Factor

Frequency (MHz)	Read Level (dBuV)	Factor (dB/m)	Level (dBuV/m)	Limit Line (dBuV/m)	Over Limit (dB)	Detector	Polarization
2402	97.20	-8.29	88.91	94	-5.09	Peak	Horizontal
	89.38	-8.29	81.09	94	-12.91	Peak	Vertical

Frequency (MHz)	Read Level (dBuV)	Factor (dB/m)	Level (dBuV/m)	Limit Line (dBuV/m)	Over Limit (dB)	Detector	Polarization
2442	102.03	-8.20	93.83	94	-0.17	Peak	Horizontal
	91.84	-8.20	83.64	94	-10.26	Peak	Vertical

Frequency (MHz)	Read Level (dBuV)	Factor (dB/m)	Level (dBuV/m)	Limit Line (dBuV/m)	Over Limit (dB)	Detector	Polarization
2480	105.41	-8.10	97.31	114	-16.69	Peak	Horizontal
	69.73	-8.10	61.63	94	-32.37	Average	Horizontal
	94.33	-8.10	86.23	94	-7.77	Peak	Vertical

Remark:

- 1) The basic equation with a sample calculation is as follows: $Level = Read\ Level + Factor$.
(The Factor is calculated by adding the Antenna Factor, Cable Loss and Preamp Factor)
- 2) If the Peak value below the Average Limit, the Average test doesn't perform for this submission.

7.3 Restricted Band Around Fundamental Frequency

Test Requirement 47 CFR Part 15, Subpart C 15.205 & 15.249(d) & 15.209
 Test Method: ANSI C63.10 (2013) Section 6.4&6.5&6.6
 Limit:

Frequency	Limit (dBuV/m @3m)	Remark
30MHz-88MHz	40.0	Quasi-peak Value
88MHz-216MHz	43.5	Quasi-peak Value
216MHz-960MHz	46.0	Quasi-peak Value
960MHz-1GHz	54.0	Quasi-peak Value
Above 1GHz	54.0	Average Value
Above 1GHz	74.0	Peak Value

Emission radiated outside of the specified frequency bands, except for harmonics, shall be attenuated by at least 50 dB below the level of the fundamental or to the general radiated emission limits in Section 15.209, whichever is the lesser attenuation.

Test Configuration: Receive antenna scan height 1 m - 4 m. polarization Vertical / Horizontal

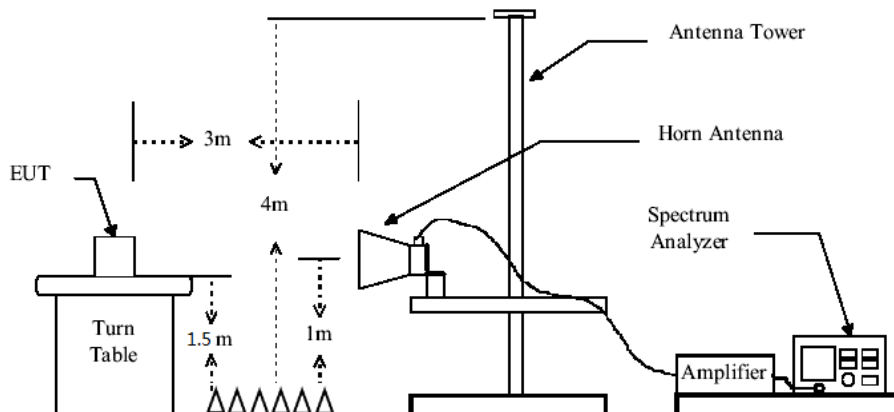

Figure3. Above 1GHz radiated emissions test configuration

7.3.1 E.U.T. Operation

Operating Environment:

Temperature: 22 °C Humidity: 50 % RH Atmospheric Pressure: 1002 mbar
 Test mode a:TX mode_Keep the EUT in transmitting with modulation mode.

7.3.2 Measurement Procedure and Data

- a. For below 1GHz, the EUT was placed on the top of a rotating table 0.8 meters above the ground at a 3 or 10 meter semi-anechoic chamber. The table was rotated 360 degrees to determine the position of the highest radiation.
 - b. For above 1GHz, the EUT was placed on the top of a rotating table 1.5 meters above the ground at a 3 meter fully-anechoic chamber. The table was rotated 360 degrees to determine the position of the highest radiation.
 - c. The EUT was set 3 or 10 meters away from the interference-receiving antenna, which was mounted on the top of a variable-height antenna tower.
 - d. The antenna height is varied from one meter to four meters above the ground to determine the maximum value of the field strength. Both horizontal and vertical polarizations of the antenna are set to make the measurement.
 - e. For each suspected emission, the EUT was arranged to its worst case and then the antenna was tuned to heights from 1 meter to 4 meters (for the test frequency of below 30MHz, the antenna was tuned to heights 1 meter) and the rotatable table was turned from 0 degrees to 360 degrees to find the maximum reading.
 - f. The test-receiver system was set to Peak Detect Function and Specified Bandwidth with Maximum Hold Mode.
 - g. If the emission level of the EUT in peak mode was 10dB lower than the limit specified, then testing could be stopped and the peak values of the EUT would be reported. Otherwise the emissions that did not have 10dB margin would be re-tested one by one using peak, quasi-peak or average method as specified and then reported in a data sheet.
 - h. Test the EUT in the lowest channel, the middle channel, the Highest channel.
 - i. The radiation measurements are performed in X, Y, Z axis positioning for Transmitting mode, and found the X axis positioning which it is the worst case.
 - j. Repeat above procedures until all frequencies measured was complete.
- Remark: Level= Read Level+ Cable Loss+ Antenna Factor- Preamp Factor

2402MHz
Horizontal

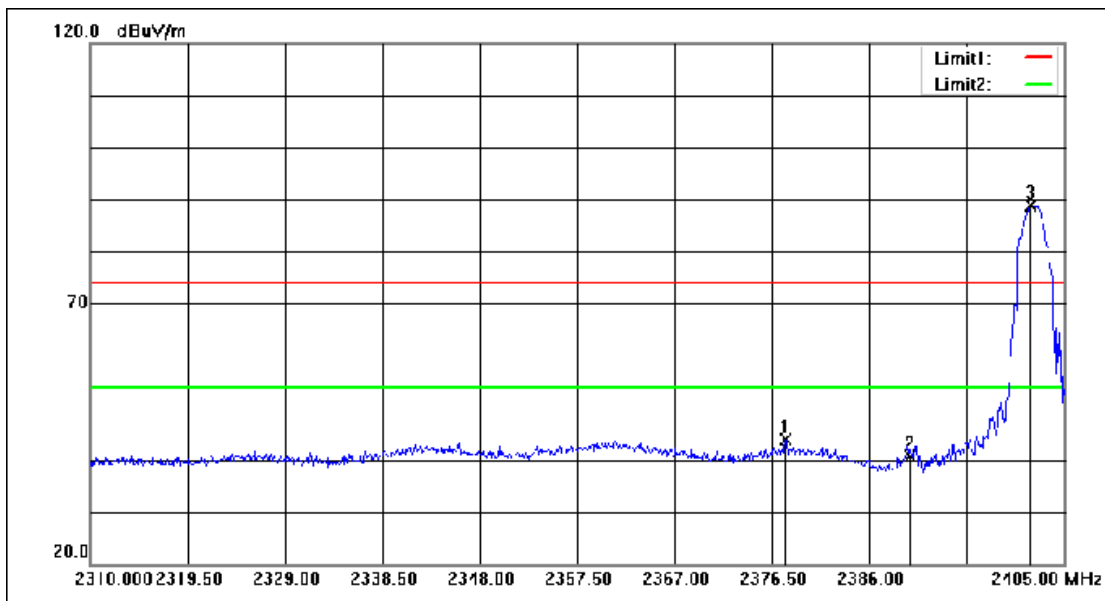

No.	Frequency (MHz)	Reading (dBuV)	Correction factor(dB/m)	Result (dBuV/m)	Limit (dBuV/m)	Margin (dB)	Remark
1	2377.830	70.07	-26.13	43.94	74.00	-30.06	peak
2	2390.000	66.68	-26.07	40.61	74.00	-33.39	peak
3	2401.770	114.92	-26.01	88.91	74.00	14.91	peak

Vertical

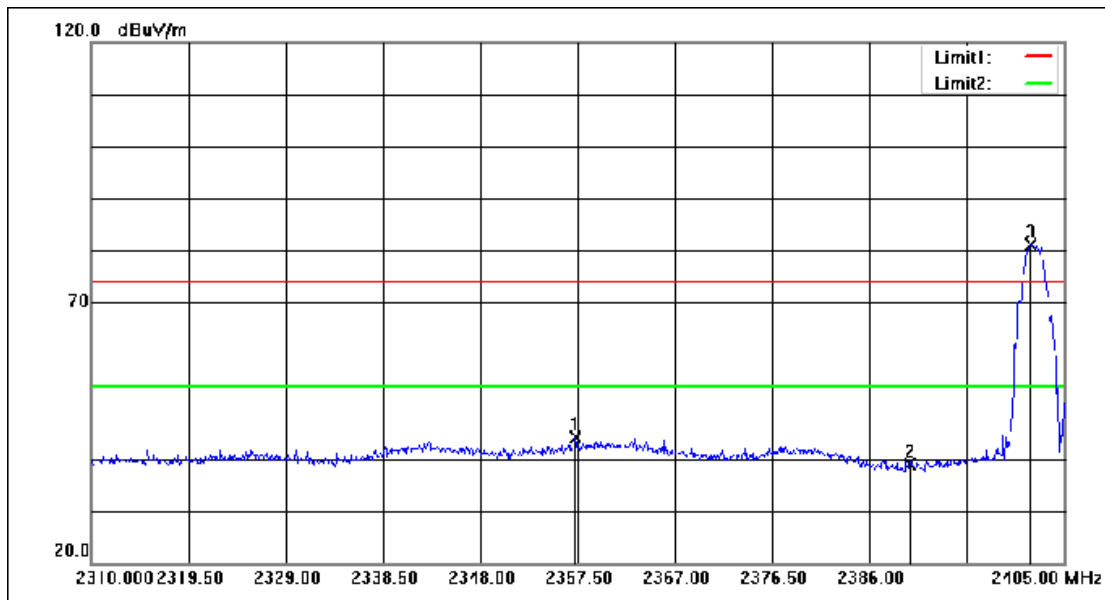

No.	Frequency (MHz)	Reading (dBuV)	Correction factor(dB/m)	Result (dBuV/m)	Limit (dBuV/m)	Margin (dB)	Remark
1	2357.310	70.36	-26.23	44.13	74.00	-29.87	peak
2	2390.000	64.96	-26.07	38.89	74.00	-35.11	peak
3	2401.770	107.10	-26.01	81.09	74.00	7.09	peak

2480MHz
Horizontal

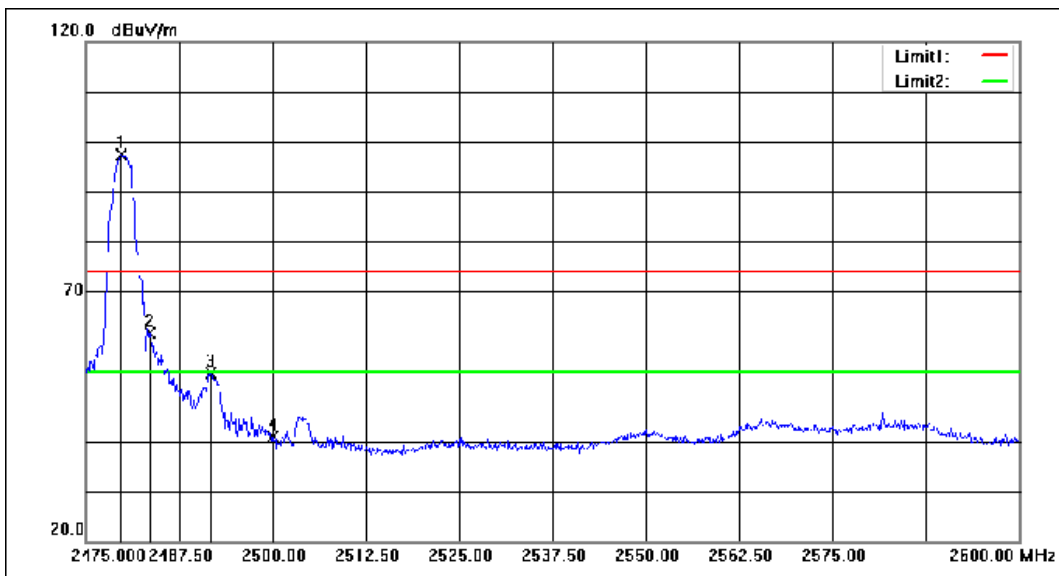

No.	Frequency (MHz)	Reading (dBuV)	Correction factor(dB/m)	Result (dBuV/m)	Limit (dBuV/m)	Margin (dB)	Remark
1	2479.750	122.93	-25.62	97.31	74.00	23.31	peak
2	2483.500	87.14	-25.60	61.54	74.00	-12.46	peak
3	2491.750	79.23	-25.56	53.67	74.00	-20.33	peak
4	2500.000	66.37	-25.52	40.85	74.00	-33.15	peak

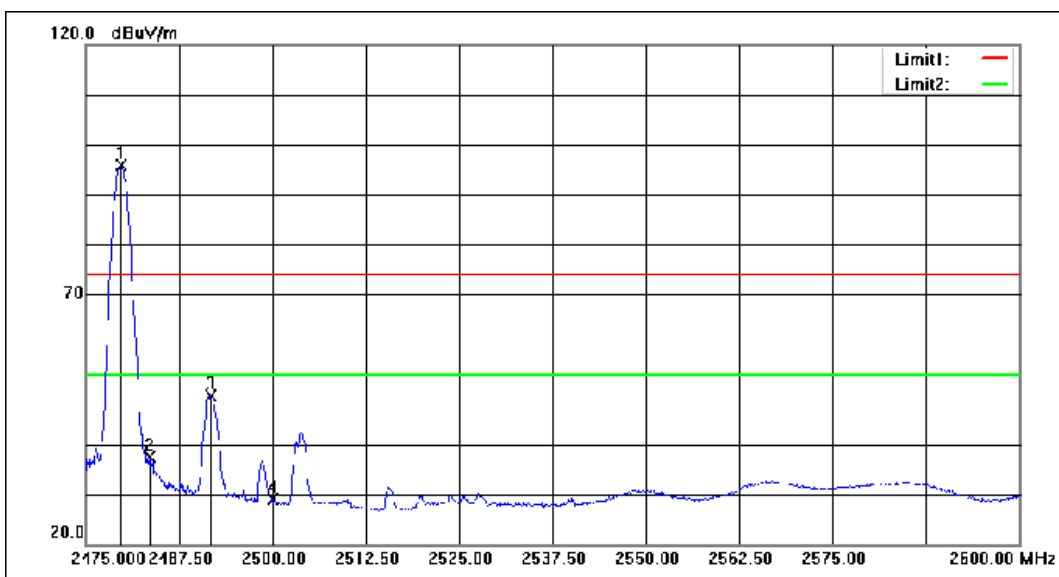

No.	Frequency (MHz)	Reading (dBuV)	Correction factor(dB/m)	Result (dBuV/m)	Limit (dBuV/m)	Margin (dB)	Remark
1	2479.750	121.45	-25.62	95.83	54.00	41.83	AVG
2	2483.500	63.05	-25.60	37.45	54.00	-16.55	AVG
3	2491.750	75.08	-25.56	49.52	54.00	-4.48	AVG
4	2500.000	54.43	-25.52	28.91	54.00	-25.09	AVG

Vertical

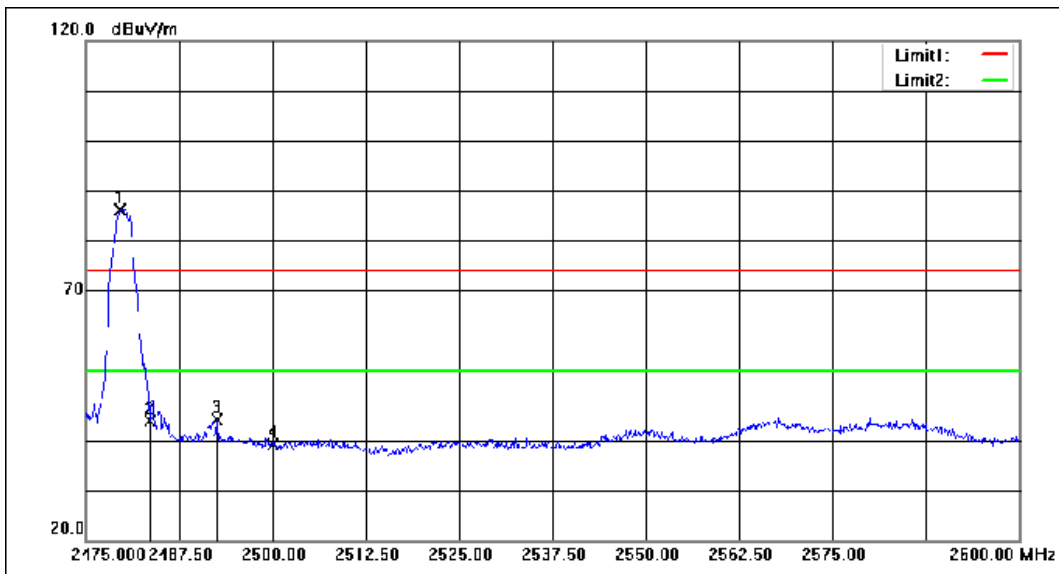

No.	Frequency (MHz)	Reading (dBuV)	Correction factor(dB/m)	Result (dBuV/m)	Limit (dBuV/m)	Margin (dB)	Remark
1	2479.625	111.85	-25.62	86.23	74.00	12.23	peak
2	2483.500	69.47	-25.60	43.87	74.00	-30.13	peak
3	2492.500	69.62	-25.56	44.06	74.00	-29.94	peak
4	2500.000	64.59	-25.52	39.07	74.00	-34.93	peak

7.4 Radiated Emissions

Test Requirement 47 CFR Part 15, Subpart C 15.209 & 15.249 (a),(d)
Test Method: ANSI C63.10 (2013) Section 6.4&6.5&6.6
Limit:

Frequency(MHz)	Field strength (microvolts/meter)	Limit (dBuV/m)	Detector	Measurement Distance (meters)
0.009-0.490	2400/F(kHz)	-	-	300
0.490-1.705	24000/F(kHz)	-	-	30
1.705-30	30	-	-	30
30-88	100	40.0	QP	3
88-216	150	43.5	QP	3
216-960	200	46.0	QP	3
960-1000	500	54.0	QP	3
Above 1000	500	54.0	AV	3

Test Configuration: Receive antenna scan height 1 m - 4 m. polarization Vertical / Horizontal

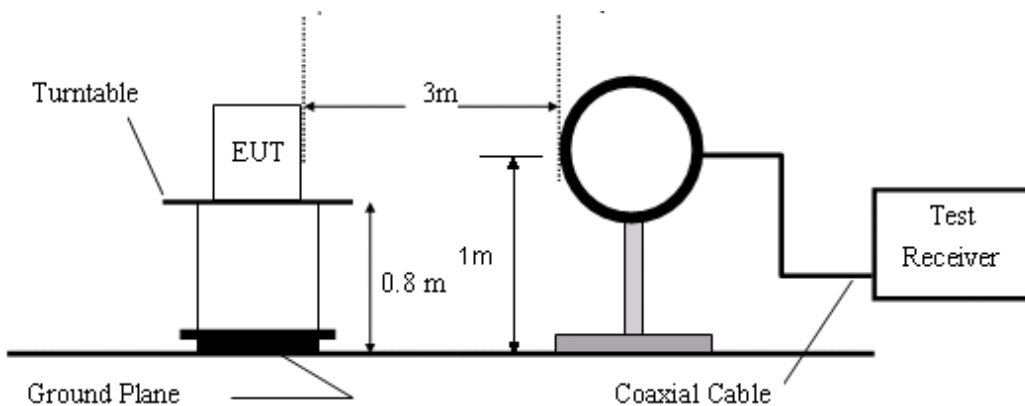

Figure1. Blow 30MHz radiated emissions test configuration

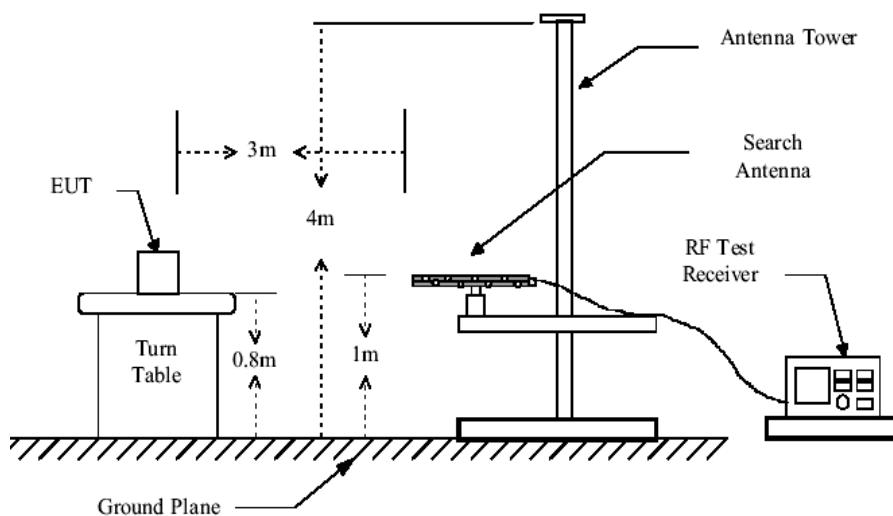

Figure2. 30MHz to 1GHz radiated emissions test configuration

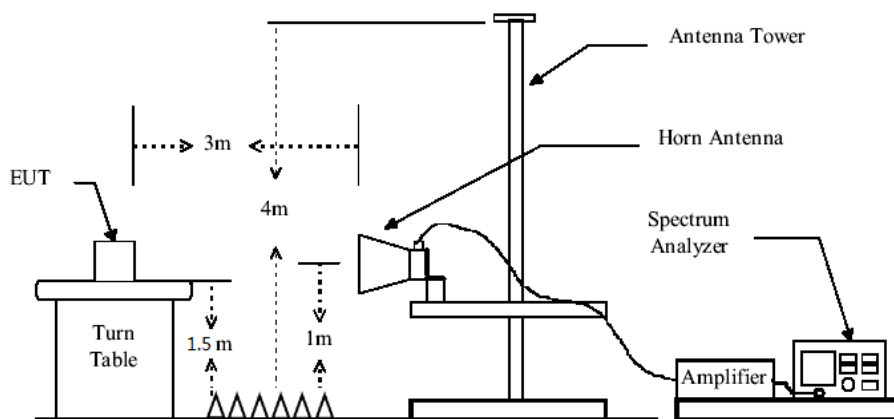

Figure3. Above 1GHz radiated emissions test configuration

7.4.1 E.U.T. Operation

Operating Environment:

Temperature: 22 °C Humidity: 50 % RH Atmospheric Pressure: 1002 mbar

Test mode a:TX mode_Keep the EUT in transmitting with modulation mode.

7.4.2 Measurement Procedure and Data

Test Procedure: a. For below 1GHz, the EUT was placed on the top of a rotating table 0.8 meters above the ground at a 3 or 10 meter semi-anechoic chamber. The table was rotated 360 degrees to determine the position of the highest radiation.

b. For above 1GHz, the EUT was placed on the top of a rotating table 1.5 meters above the ground at a 3 meter fully-anechoic chamber. The table was rotated 360 degrees to determine the position of the highest radiation.

c. The EUT was set 3 or 10 meters away from the interference-receiving antenna, which was mounted on the top of a variable-height antenna tower.

d. The antenna height is varied from one meter to four meters above the ground to determine the maximum value of the field strength. Both horizontal and vertical polarizations of the antenna are set to make the measurement.

e. For each suspected emission, the EUT was arranged to its worst case and then the antenna was tuned to heights from 1 meter to 4 meters (for the test frequency of below 30MHz, the antenna was tuned to heights 1 meter) and the rotatable table was turned from 0 degrees to 360 degrees to find the maximum reading.

f. The test-receiver system was set to Peak Detect Function and Specified Bandwidth with Maximum Hold Mode.

g. If the emission level of the EUT in peak mode was 10dB lower than the limit specified, then testing could be stopped and the peak values of the EUT would be reported. Otherwise the emissions that did not have 10dB margin would be re-tested one by one using peak, quasi-peak or average method as specified and then reported in a data sheet.

h. Test the EUT in the lowest channel, the middle channel, the Highest channel.

i. The radiation measurements are performed in X, Y, Z axis positioning for Transmitting mode, and found the X axis positioning which it is the worst case.

j. Repeat above procedures until all frequencies measured was complete.

Remark:

1) For emission below 1GHz, through pre-scan found the worst case is the lowest channel. Only the worst case is recorded in the report.

2) The field strength is calculated by adding the Antenna Factor, Cable Factor & Preamplifier. The basic equation with a sample calculation is as follows:

Final Test Level = Receiver Reading + Antenna Factor + Cable Factor – Preamplifier Factor

3) Scan from 9kHz to 25GHz, the disturbance above 18GHz and below 30MHz was very low. The points marked on above plots are the highest emissions could be found when testing, so only above points had been



displayed. The amplitude of spurious emissions from the radiator which are attenuated more than 20dB below the limit need not be reported.

4) For frequencies above 1GHz, the field strength limits are based on average limits. However, the peak field strength of any emission shall not exceed the maximum permitted average limits specified above by more than 20 dB under any condition of modulation. For the emissions whose peak level is lower than the average limit, only the peak measurement is shown

30MHz-1GHz:

Vertical:

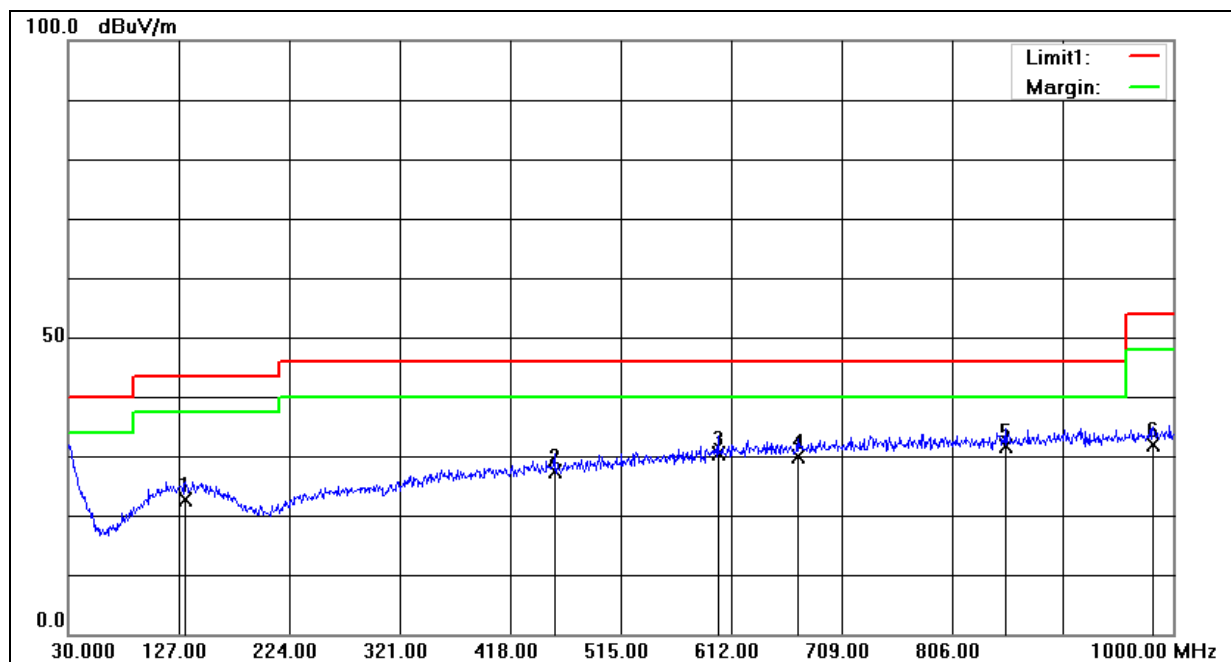

No.	Frequency (MHz)	Reading (dBuV)	Correct Factor(dB/m)	Result (dBuV/m)	Limit (dBuV/m)	Margin (dB)	Remark
1	132.8200	2.99	19.66	22.65	43.50	-20.85	QP
2	456.8000	2.69	24.60	27.29	46.00	-18.71	QP
3	600.3600	3.77	26.59	30.36	46.00	-15.64	QP
4	670.2000	2.47	27.38	29.85	46.00	-16.15	QP
5	852.5600	3.02	28.49	31.51	46.00	-14.49	QP
6	982.5400	2.37	29.39	31.76	54.00	-22.24	QP

Horizontal:

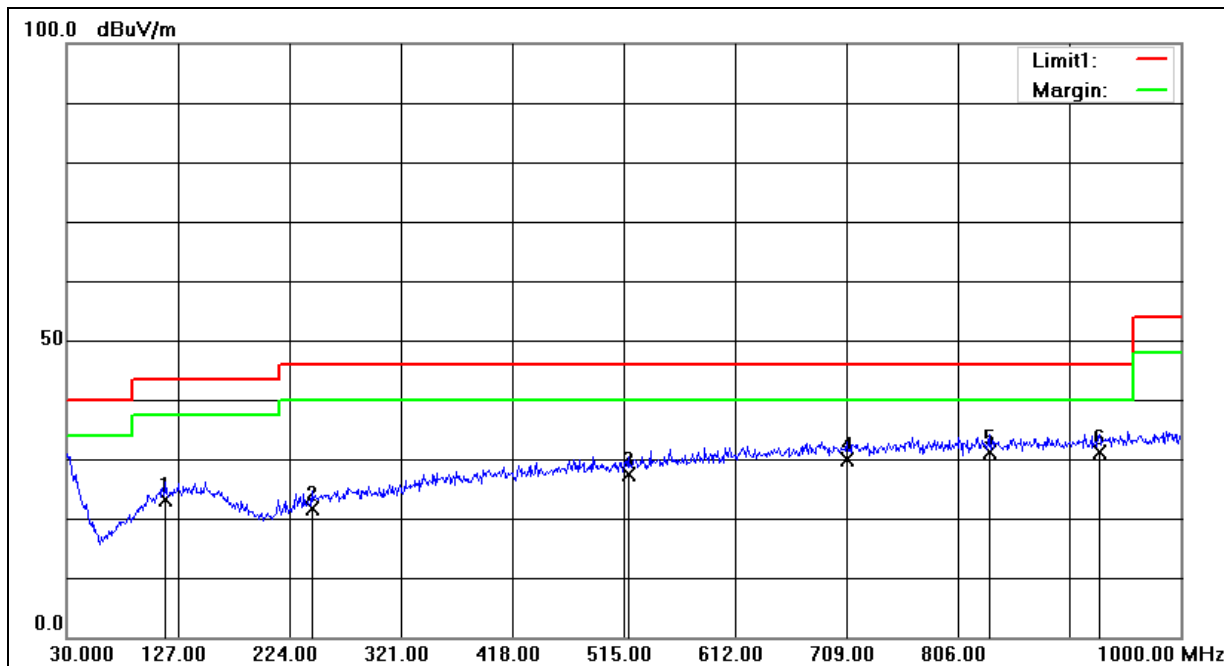

No.	Frequency (MHz)	Reading (dBuV)	Correct Factor(dB/m)	Result (dBuV/m)	Limit (dBuV/m)	Margin (dB)	Remark
1	116.3300	3.88	19.14	23.02	43.50	-20.48	QP
2	243.4000	2.53	19.03	21.56	46.00	-24.44	QP
3	518.8800	1.96	25.47	27.43	46.00	-18.57	QP
4	709.0000	2.04	27.77	29.81	46.00	-16.19	QP
5	833.1600	2.71	28.39	31.10	46.00	-14.90	QP
6	929.1900	2.18	28.95	31.13	46.00	-14.87	QP

Above 1GHz:
Mode:a; Horizontal; Lowest

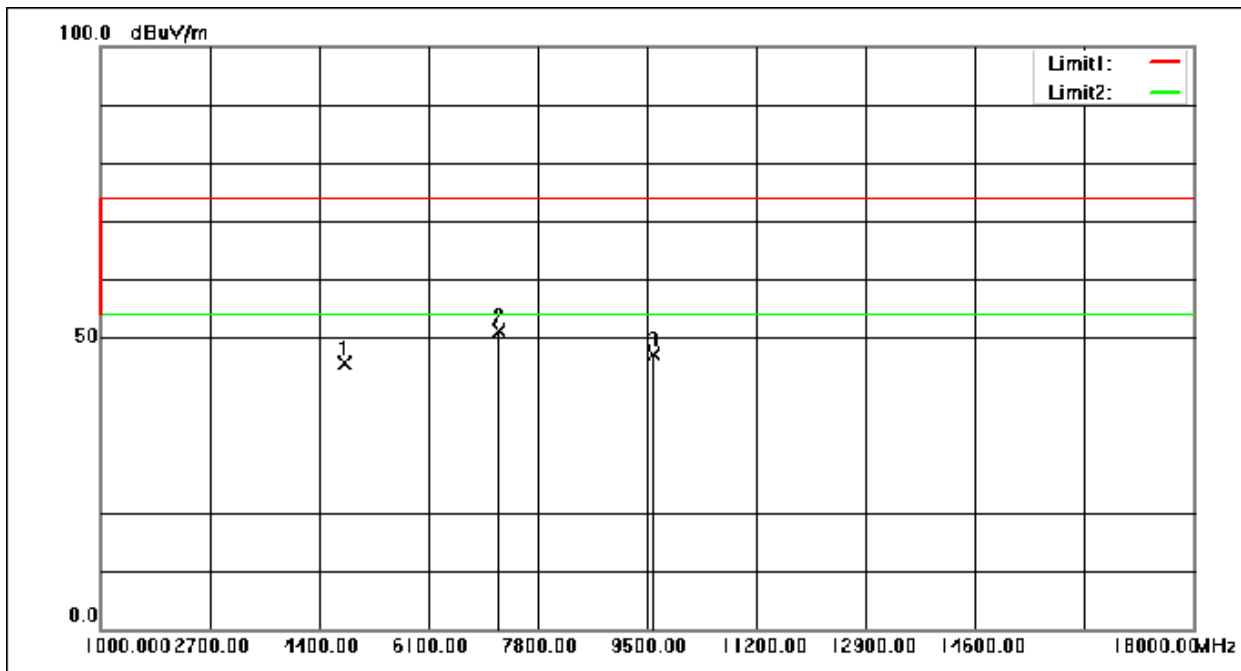

No.	Frequency (MHz)	Reading (dBuV)	Correction factor(dB/m)	Result (dBuV/m)	Limit (dBuV/m)	Margin (dB)	Remark
1	4804.000	65.00	-19.33	45.67	74.00	-28.33	peak
2	7206.000	63.26	-12.10	51.16	74.00	-22.84	peak
3	9608.000	55.83	-8.80	47.03	74.00	-26.97	peak

Mode:a; Vertical; Lowest

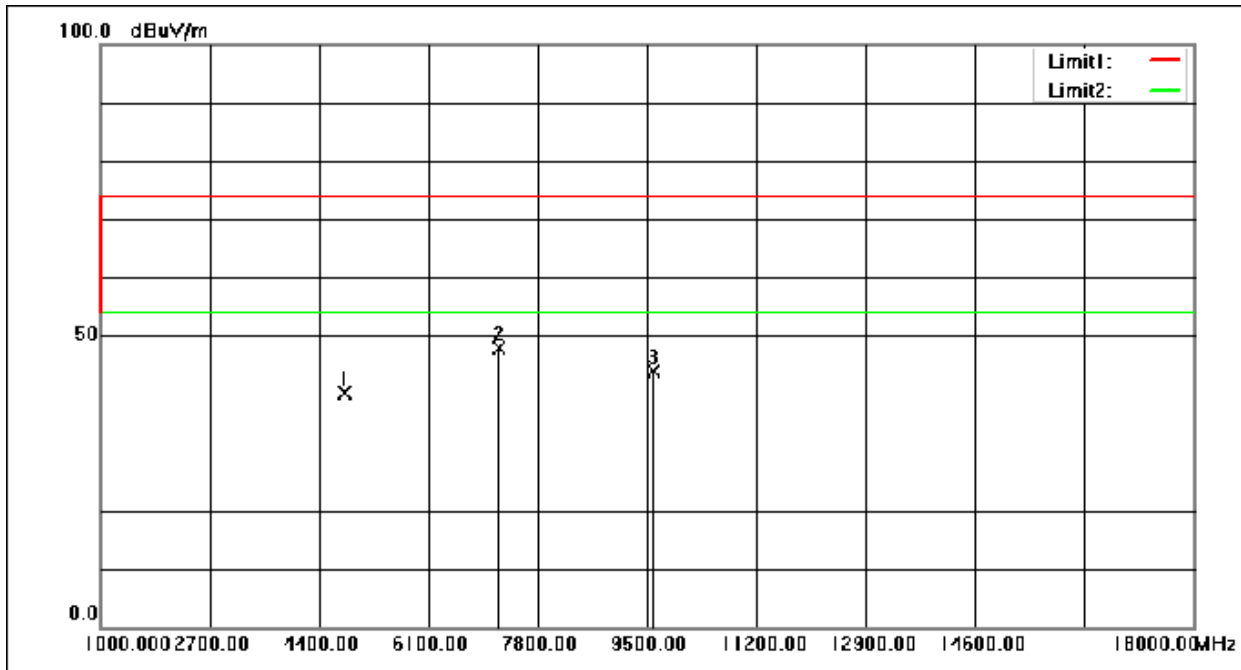

No.	Frequency (MHz)	Reading (dBuV)	Correction factor(dB/m)	Result (dBuV/m)	Limit (dBuV/m)	Margin (dB)	Remark
1	4804.000	59.54	-19.33	40.21	74.00	-33.79	peak
2	7206.000	60.06	-12.10	47.96	74.00	-26.04	peak
3	9608.000	52.58	-8.80	43.78	74.00	-30.22	peak

Mode:a; Horizontal; Middle

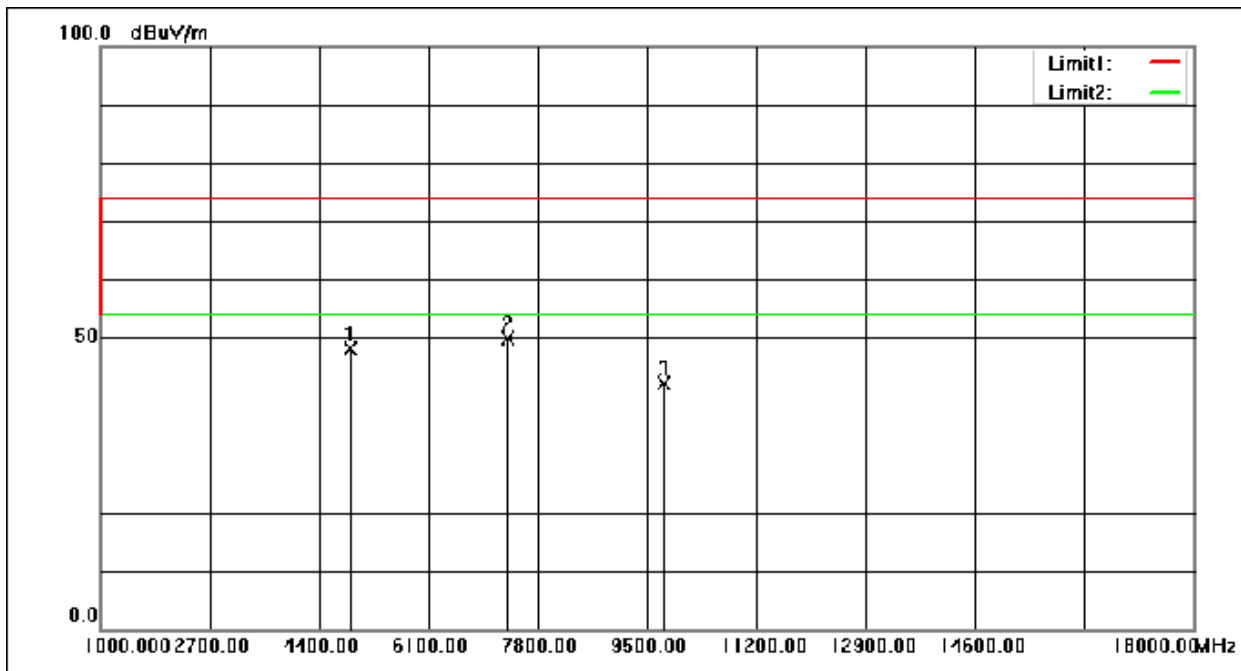

No.	Frequency (MHz)	Reading (dBuV)	Correction factor(dB/m)	Result (dBuV/m)	Limit (dBuV/m)	Margin (dB)	Remark
1	4884.000	67.13	-19.01	48.12	74.00	-25.88	peak
2	7326.000	61.52	-11.76	49.76	74.00	-24.24	peak
3	9768.000	50.61	-8.47	42.14	74.00	-31.86	peak

Mode:a; Vertical; Middle

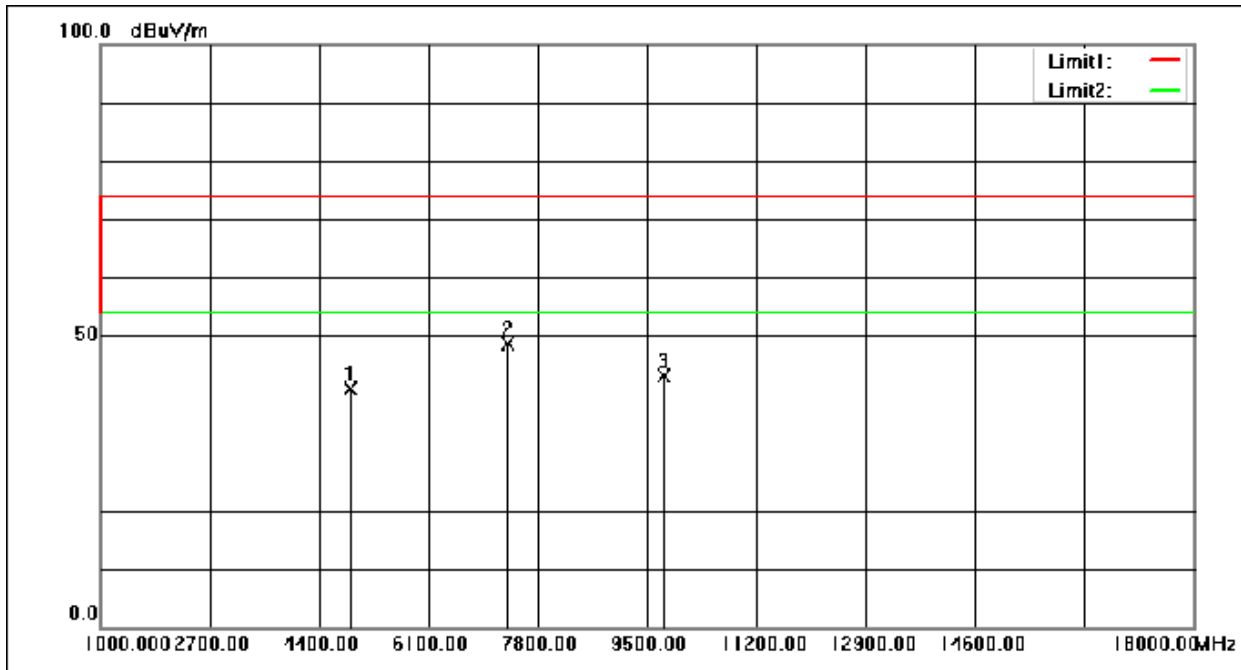

No.	Frequency (MHz)	Reading (dBuV)	Correction factor(dB/m)	Result (dBuV/m)	Limit (dBuV/m)	Margin (dB)	Remark
1	4884.000	59.78	-19.01	40.77	74.00	-33.23	peak
2	7326.000	60.39	-11.76	48.63	74.00	-25.37	peak
3	9768.000	51.66	-8.47	43.19	74.00	-30.81	peak

Mode:a; Horizontal; Highest

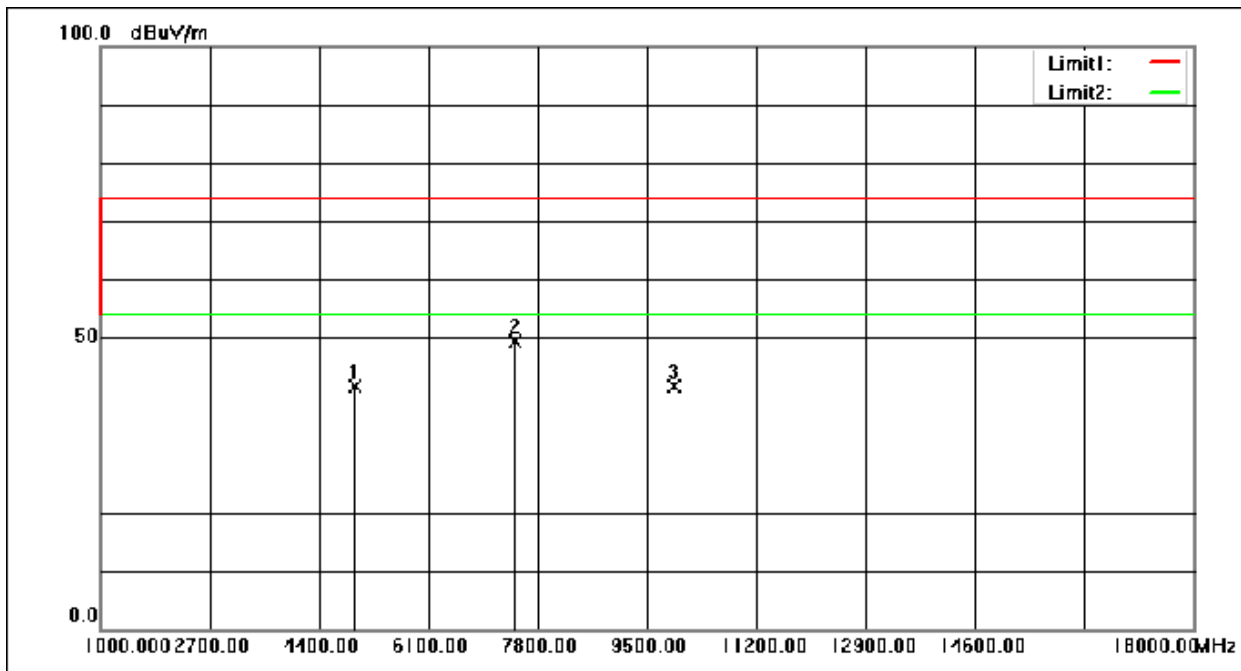

No.	Frequency (MHz)	Reading (dBuV)	Correction factor(dB/m)	Result (dBuV/m)	Limit (dBuV/m)	Margin (dB)	Remark
1	4960.000	60.26	-18.70	41.56	74.00	-32.44	peak
2	7440.000	60.94	-11.44	49.50	74.00	-24.50	peak
3	9920.000	49.74	-8.16	41.58	74.00	-32.42	peak

Mode:a; Vertical; Highest

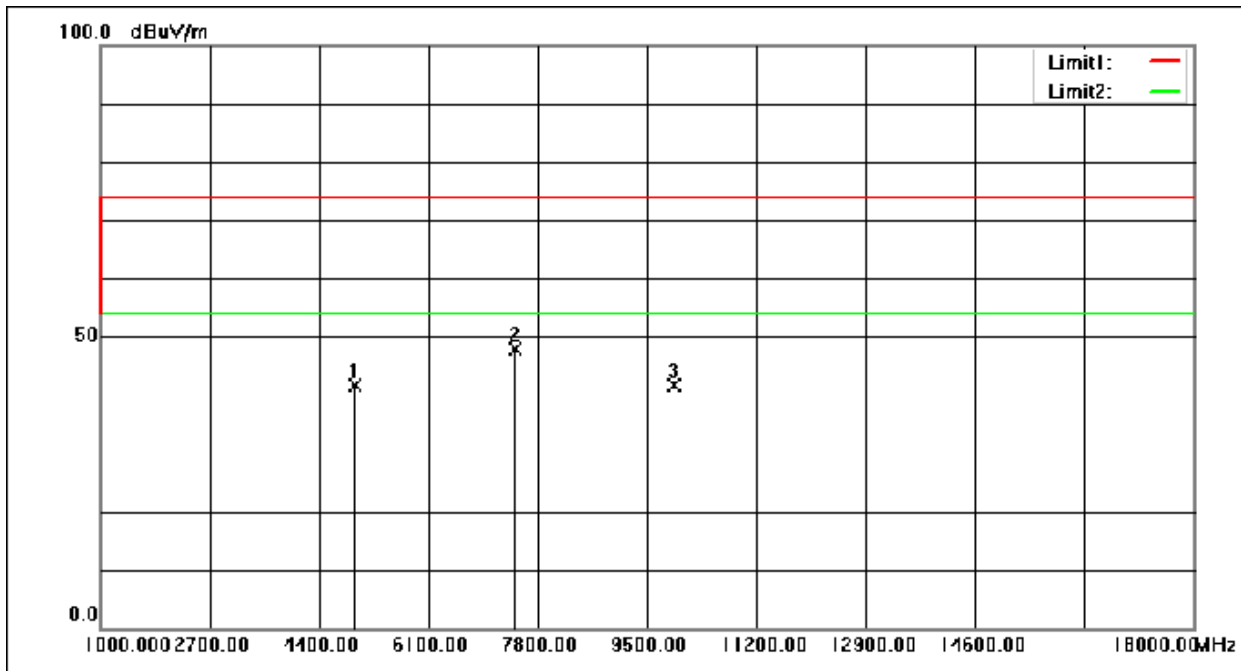

No.	Frequency (MHz)	Reading (dBuV)	Correction factor(dB/m)	Result (dBuV/m)	Limit (dBuV/m)	Margin (dB)	Remark
1	4960.000	60.26	-18.70	41.56	74.00	-32.44	peak
2	7440.000	59.34	-11.44	47.90	74.00	-26.10	peak
3	9920.000	49.84	-8.16	41.68	74.00	-32.32	peak



8 Test Setup Photographs

Refer to the < Test Setup photos-FCC>.

9 EUT Constructional Details

Refer to the < External Photos > & < Internal Photos >.

- End of the Report -