



# **FCC TEST REPORT**

**FCC ID: 2ARJA-A9**

On Behalf of

**Vsoon Smart Manufacture Co., Ltd.**

**WiFi display receiver**

**Model No.: A9, A1, A2, A3, A5, A6, A7, A8, A10, A12, D1, D2, D3,  
D5, D6, D7, D8, DA9, DA10, G1, G2, G3, G5, G6, G7, G8, G9, G10,  
R1, R2, R3, R5, R6, R7, R8, R9, R10, R11, R13, R15, R16**

Prepared for : Vsoon Smart Manufacture Co., Ltd.  
Address : The 3rd Floor, B5 Building, Huachuang Industry Park, No.9, Huateng  
Road, Shiqi Town, Panyu District, Guangzhou, Guangdong, China

Prepared By : Shenzhen Alpha Product Testing Co., Ltd.  
Address : Building i, No.2, Lixin Road, Fuyong Street, Bao'an District, 518103,  
Shenzhen, Guangdong, China

Report Number : T1904178-C01-R01  
Date of Receipt : June 11, 2019  
Date of Test : June 12-22, 2019  
Date of Report : June 22, 2019  
Version Number : V0

## TABLE OF CONTENTS

Description	Page
<b>1. Summary of Standards And Results-----</b>	<b>6</b>
1.1. Description of Standards and Results -----	6
<b>2. General Information -----</b>	<b>7</b>
2.1. Description of Device (EUT)-----	7
2.2. Accessories of Device (EUT) -----	8
2.3. Tested Supporting System Details -----	8
2.4. Block Diagram of connection between EUT and simulators -----	8
2.5. Test Mode Description -----	9
2.6. Test Conditions -----	10
2.7. Test Facility -----	10
2.8. Measurement Uncertainty -----	11
2.9. Test Equipment List -----	12
<b>3. Spurious Emission -----</b>	<b>13</b>
3.1. Test Limits -----	13
3.2. Test Procedure -----	13
3.3. Test Setup -----	14
3.4. Test Results -----	15
<b>4. Power line Conducted Emission -----</b>	<b>22</b>
4.1. Test Limits -----	22
4.2. Test Procedure -----	22
4.3. Test Setup -----	22
4.4. Test Results -----	23
<b>5. Conducted Maximum Output Power -----</b>	<b>25</b>
5.1. Test limits -----	25
5.2. Test Procedure -----	25
5.3. Test Setup -----	25
5.4. Test Results -----	25
<b>6. Peak Power Spectral Density-----</b>	<b>27</b>
6.1. Test limits -----	27
6.2. Test Procedure -----	27
6.3. Test Setup -----	27
6.4. Test Results -----	28
<b>7. Bandwidth-----</b>	<b>35</b>
7.1. Test limits -----	35
7.2. Test Procedure -----	35
7.3. Test Setup -----	35
7.4. Test Results -----	35
<b>8. Band Edge Check-----</b>	<b>42</b>
8.1. Test limits -----	42
8.2. Test Procedure -----	42
8.3. Test Setup -----	42
8.4. Test Results -----	42

- 9. Antenna Requirement ----- 49**
  - 9.1. Standard Requirement----- 49
  - 9.2. Antenna Connected Construction----- 49
  - 9.3. Results ----- 49
- 10. Test setup photo ----- 50**
  - 10.1. Photos of Radiated emission ----- 50
  - 10.2. Photos of Conducted Emission test----- 51
- 11. Test setup photo ----- 52**

### TEST REPORT DECLARATION

Applicant : Vsoon Smart Manufacture Co., Ltd.  
 Address : The 3rd Floor, B5 Building, Huachuang Industry Park, No.9, Huateng Road, Shiqi Town, Panyu District, Guangzhou, Guangdong, China  
 Manufacturer : Vsoon Smart Manufacture Co., Ltd.  
 Address : The 3rd Floor, B5 Building, Huachuang Industry Park, No.9, Huateng Road, Shiqi Town, Panyu District, Guangzhou, Guangdong, China  
 EUT Description : WiFi display receiver

(A) Model No. : A9, A1, A2, A3, A5, A6, A7, A8, A10, A12, D1, D2, D3, D5, D6, D7, D8, DA9, DA10, G1, G2, G3, G5, G6, G7, G8, G9, G10, R1, R2, R3, R5, R6, R7, R8, R9, R10, R11, R13, R15, R16  
 (B) Trademark : N/A

Measurement Standard Used:

**FCC Rules and Regulations Part 15 Subpart C Section 15.247**  
**ANSI C63.10:2013**

The device described above is tested by Shenzhen Alpha Product Testing Co., Ltd. to determine the maximum emission levels emanating from the device. The maximum emission levels are compared to the FCC Part 15 Subpart C limits both conducted and radiated emissions. The test results are contained in this test report and Shenzhen Alpha Product Testing Co., Ltd. is assumed of full responsibility for the accuracy and completeness of these tests.

After the test, our opinion is that EUT compliance with the requirement of the above standards.

This report applies to above tested sample only. This report shall not be reproduced in parts without written approval of Shenzhen Alpha Product Testing Co., Ltd.

Tested by (name + signature).....: Lucas Pang  
Project Engineer



Approved by (name + signature).....: Simple Guan  
Project Manager



Date of issue..... : June 22, 2019

**Revision History**

Revision	Issue Date	Revisions	Revised By
V0	June 22, 2019	Initial released Issue	Simple Guan

## 1. SUMMARY OF STANDARDS AND RESULTS

### 1.1. Description of Standards and Results

The EUT have been tested according to the applicable standards as referenced below:

<b>Test Item</b>	<b>Test Requirement</b>	<b>Standards Paragraph</b>	<b>Result</b>
Conducted Emission	FCC PART 15	15.207	P
6dB Bandwidth	FCC PART 15	15.247 (a)(2)	P
Output Power	FCC PART 15	15.247 (b)(3)	P
Radiated Spurious Emission	FCC PART 15	15.247 (c)	P
Conducted Spurious & Band Edge Emission	FCC PART 15	15.247 (d)	P
Power Spectral Density	FCC PART 15	15.247 (e)	P
Radiated Band Edge Emission	FCC PART 15	15.205	P
Antenna Requirement	FCC PART 15	15.203	P
Note:	1. P is an abbreviation for Pass. 2. F is an abbreviation for Fail. 3. N/A is an abbreviation for Not Applicable.		

## 2. GENERAL INFORMATION

### 2.1. Description of Device (EUT)

Description	: WiFi display receiver
Model Number	: A9, A1, A2, A3, A5, A6, A7, A8, A10, A12, D1, D2, D3, D5, D6, D7, D8, DA9, DA10, G1, G2, G3, G5, G6, G7, G8, G9, G10, R1, R2, R3, R5, R6, R7, R8, R9, R10, R11, R13, R15, R16
Diff	: Except for appearance color and model name, there is no difference between all models. The main test model <b>A9</b> in this report.
Trademark	: N/A
Test Voltage	: DC 5V from USB port
Operation frequency	: 2412MHz-2462MHz for IEEE 802.11 b, g, n/HT20, 2422MHz~2452MHz for IEEE802.11n/HT40
Channel No.	: 802.11b/802.11g /802.11n(HT20): 11 802.11(HT40): 7
Modulation type	: IEEE 802.11b: DSSS(CCK,DQPSK,DBPSK) IEEE 802.11g: OFDM(64QAM, 16QAM, QPSK, BPSK) IEEE 802.11n :OFDM(64QAM, 16QAM, QPSK, BPSK)
Antenna Type	: FPC Antenna, Maximum Gain is 2.5dBi
Antenna connector type	: ipex connector
Software version	: 1030.32.0201.2018
Hardware version	: V1.2

## 2.2. Accessories of Device (EUT)

Accessories1 : /  
Manufacturer : /  
Model : /  
Power supply : /

## 2.3. Tested Supporting System Details

No.	Description	Manufacturer	Model	Serial Number	Certification or DOC
1	Notebook	ACER	ZQT	N/A	DOC
2	TV	TCL	/	/	/
3	HDMI cable	/	/	/	/
4	USB cable	/	/	/	/

## 2.4. Block Diagram of connection between EUT and simulators

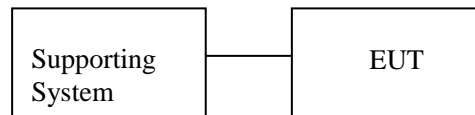



## 2.5.Test Mode Description

Duty cycle :100% Keeping TX			
Mode	data rate (Mbps)(see Note)	Channel	Frequency (MHz)
IEEE 802.11b	1	Low :CH1	2412
	1	Middle: CH6	2437
	1	High: CH11	2462
IEEE 802.11g	6	Low :CH1	2412
	6	Middle: CH6	2437
	6	High: CH11	2462
IEEE 802.11 n/HT20 with 2.4G	6.5	Low :CH1	2412
	6.5	Middle: CH6	2437
	6.5	High: CH11	2462
IEEE 802.11 n/HT40 with 2.4G	13	Low :CH3	2422
	13	Middle: CH6	2437
	13	High: CH9	2452

Note: According exploratory test, EUT will have maximum output power in those data rate. so those data rate were used for all test.

Channel list:					
For IEEE 802.11b, g, n/HT20 and IEEE 802.11 n/HT40 with 2.4G					
Channel	Frequency (MHz)	Channel	Frequency (MHz)	Channel	Frequency (MHz)
CH1	2412	CH5	2432	CH9	2452
CH2	2417	CH6	2437	CH10	2457
CH3	2422	CH7	2442	CH11	2462
CH4	2427	CH8	2447		

Setting output power (Max)			
802.11b	802.11g	802.11n(HT20)	802.11n(HT40)
20dBm	20dBm	20dBm	20dBm

## 2.6. Test Conditions

Items	Required	Actual
Temperature range:	15-35°C	27°C
Humidity range:	25-75%	56%
Pressure range:	86-106kPa	980kPa

## 2.7. Test Facility

Shenzhen Alpha Product Testing Co., Ltd  
Building i, No.2, Lixin Road, Fuyong Street, Bao'an District, 518103,  
Shenzhen, Guangdong, China

June 21, 2018 File on Federal Communication Commission  
Registration Number: 293961

July 25, 2017 Certificated by IC  
Registration Number: 12135A

## 2.8.Measurement Uncertainty

(95% confidence levels, k=2)

Item	Uncertainty
Uncertainty for Power point Conducted Emissions Test	2.74dB
Uncertainty for Radiation Emission test in 3m chamber (below 30MHz)	2.13 dB(Polarize: V)
	2.57dB(Polarize: H)
Uncertainty for Radiation Emission test in 3m chamber (30MHz to 1GHz)	3.77dB(Polarize: V)
	3.80dB(Polarize: H)
Uncertainty for Radiation Emission test in 3m chamber (1GHz to 25GHz)	4.16dB(Polarize: H)
	4.13dB(Polarize: V)
Uncertainty for radio frequency	$5.4 \times 10^{-8}$
Uncertainty for conducted RF Power	0.37dB
Uncertainty for temperature	0.2°C
Uncertainty for humidity	1%
Uncertainty for DC and low frequency voltages	0.06%

## 2.9. Test Equipment List

Equipment	Manufacture	Model No.	Serial No.	Last cal.	Cal Interval
9*6*6 anechoic chamber	CHENYU	9*6*6	N/A	2018.09.21	1 Year
Spectrum analyzer	ROHDE&SCHWARZ	FSU	1166.1660.26	2018.09.21	1 Year
Receiver	ROHDE&SCHWARZ	ESR	1316.3003K03-10208 2-Wa	2018.09.21	1 Year
Receiver	R&S	ESCI	101165	2018.09.21	1 Year
Bilog Antenna	Schwarzbeck	VULB 9168	VULB9168-438	2018.04.13	2 Year
Horn Antenna	SCHWARZBECK	BBHA 9120 D	BBHA 9120 D(1201)	2018.04.13	2 Year
Active Loop Antenna	SCHWARZBECK	FMZB 1519B	00059	2018.09.26	2 Year
Cable	Resenberger	N/A	No.1	2018.09.21	1 Year
Cable	Resenberger	N/A	No.2	2018.09.21	1 Year
Cable	Resenberger	N/A	No.3	2018.09.21	1 Year
Pre-amplifier	HP	HP8347A	2834A00455	2018.09.21	1 Year
Pre-amplifier	Agilent	8449B	3008A02664	2018.09.21	1 Year
L.I.S.N.#1	Schwarzbeck	NSLK8126	8126466	2018.09.21	1 Year
L.I.S.N.#2	ROHDE&SCHWARZ	ENV216	101043	2018.09.21	1 Year
20db Attenuator	ICPROBING	IATS1	82347	2018.09.21	1 Year
Horn Antenna	A-INFOMW	LB-180100-KF	J211020657	2018.09.21	2 Year
Preamplifier	SKET	LNPA_1840-50	SK2018101801	2018.09.21	1 Year
Power Meter	Agilent	E9300A	MY41496625	2018.09.21	1 Year
Temp. & Humid. Chamber	Weihuang	WHTH-1000-40-8 80	100631	2018.9.11	1 Year
Switching Mode Power Supply	JUNKE	JK12010S	20140927-6	2018.09.11	1 Year

### 3. SPURIOUS EMISSION

#### 3.1. Test Limits

Frequencies (MHz)	Field Strength (micorvolts/meter)	Measurement Distance (meters)
0.009~0.490	2400/F(KHz)	300
0.490~1.705	24000/F(KHz)	30
1.705~30.0	30	30
30~88	100	3
88~216	150	3
216~960	200	3
Above 960	500	3

Harmonic emissions limits comply with below 54 dBuV/m at 3m. Other emissions radiated outside of the specified frequency bands, except for harmonics, shall be attenuated by at least 50 dB below the level of the fundamental or comply with the radiated emissions limits specified in section 15.209(a) limit in the table below has to be followed.

**NOTE:**

- a) The tighter limit applies at the band edges.
- b) Emission Level(dB uV/m)=20log Emission Level(Uv/m)

#### 3.2. Test Procedure

The measuring distance of 3m shall be used for measurements at frequency up to 1GHz and above 1GHz, The EUT was placed on a rotating 0.8 m high above ground, The table was rotated 360 degrees to determine the position of the highest radiation

The Test antenna shall vary between 1m and 4m,Both Horizontal and Vertical antenna are set of make measurement.

The initial step in collecting conducted emission data is a spectrum analyzer Peak detector mode pre-scanning the measurement frequency range. Significant Peaks are then marked. and then Qusia Peak Detector mode premeasured

If Peak value comply with QP limit Below 1GHz.The EUT deemed to comply with QP limit. But the Peak value and average value both need to comply with applicable limit above 1GHz.

For the actual test configuration, please see the test setup photo.

### 3.3. Test Setup

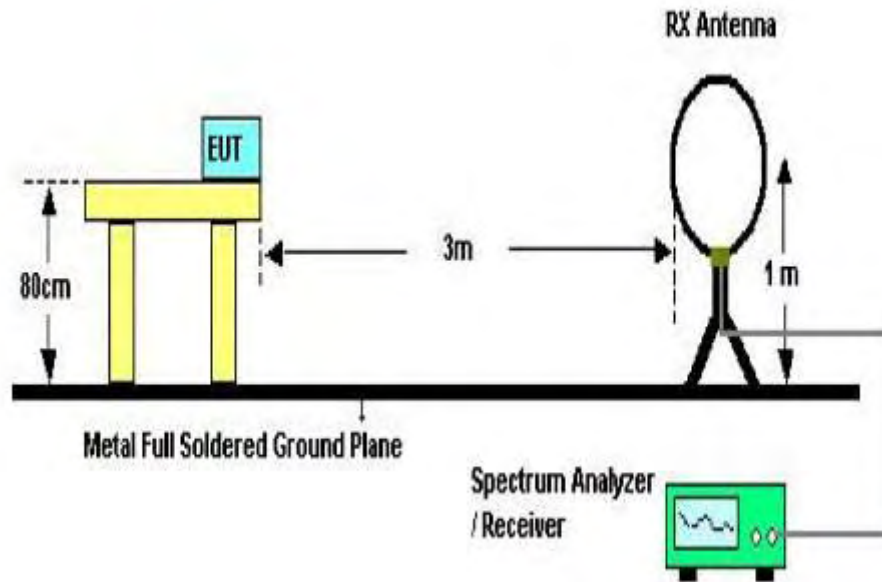

Below 30MHz Test Setup

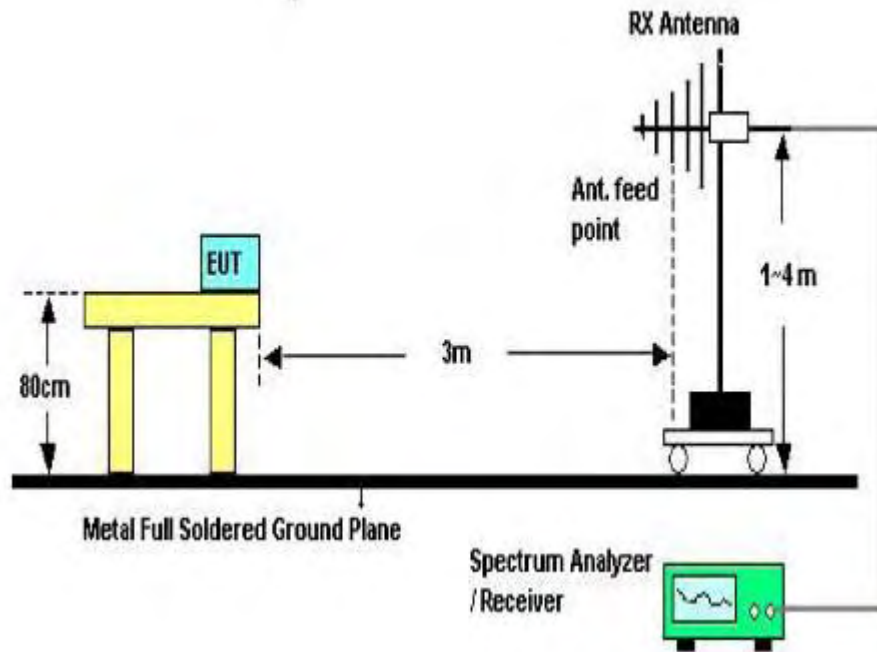

Above 30MHz Test Setup

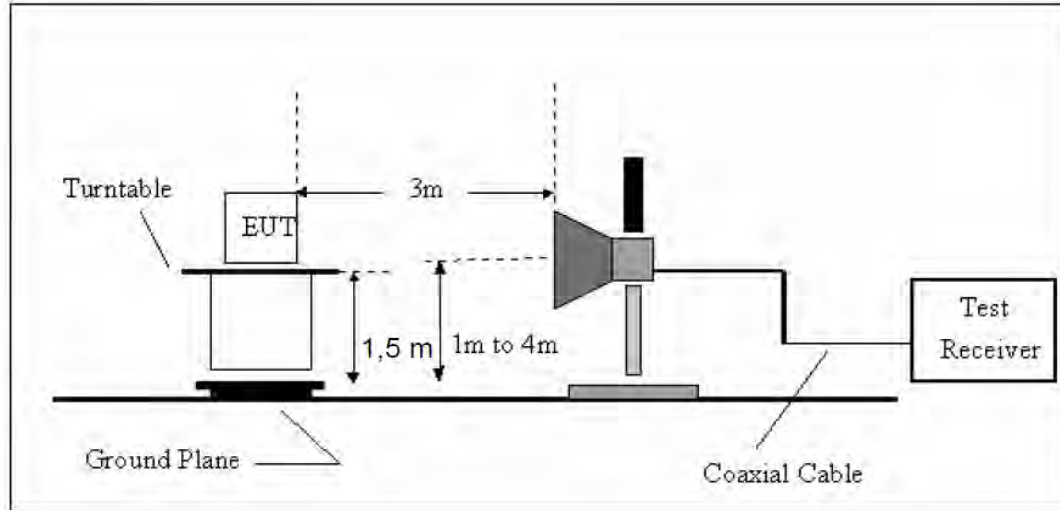

Above 1GHz Test Setup

### 3.4. Test Results

#### Test Condition

Continual Transmitting in maximum power.

9KHz~150KHz	RBW200Hz	VBW1KHz
150KHz~30MHz	RBW9KHz	VBW 30KHz
30MHz~1GHz	RBW120KHz	VBW 300KHz
Above1GHz	RBW1MHz	VBW 3MHz

We have scanned the 10th harmonic from 9 kHz to the EUT.

Detailed information please see the following page.

From 9KHz to 30MHz: Conclusion: PASS

Note:1.The amplitude of spurious emissions which are attenuated by more than 20dB below the permissible value has no need to be reported.

2.Only show the test data of the worst Channel in this report.

Test result for 802.11 n/HT40 (High Channel), AC 120V/ 60Hz  
Vertical

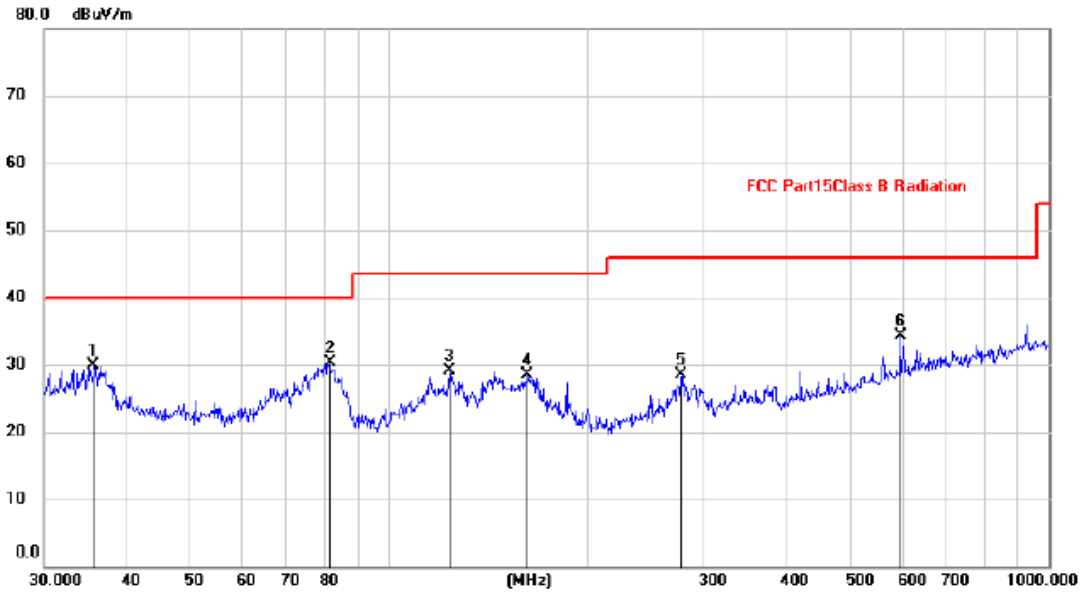

No. Mk.	Freq. MHz	Reading Level dBuV	Correct Factor dB	Measure- ment dBuV/m	Limit dBuV/m	Margin dB	Detector	Antenna Height cm	Table Degree	Comment
1	35.6240	16.43	13.51	29.94	40.00	-10.06	peak			
2 *	80.9275	20.82	9.49	30.31	40.00	-9.69	peak			
3	123.6985	16.18	12.83	29.01	43.50	-14.49	peak			
4	162.6106	14.11	14.37	28.48	43.50	-15.02	peak			
5	278.0668	15.50	12.94	28.44	46.00	-17.56	peak			
6	595.1329	15.19	19.17	34.36	46.00	-11.64	peak			



### Horizontal

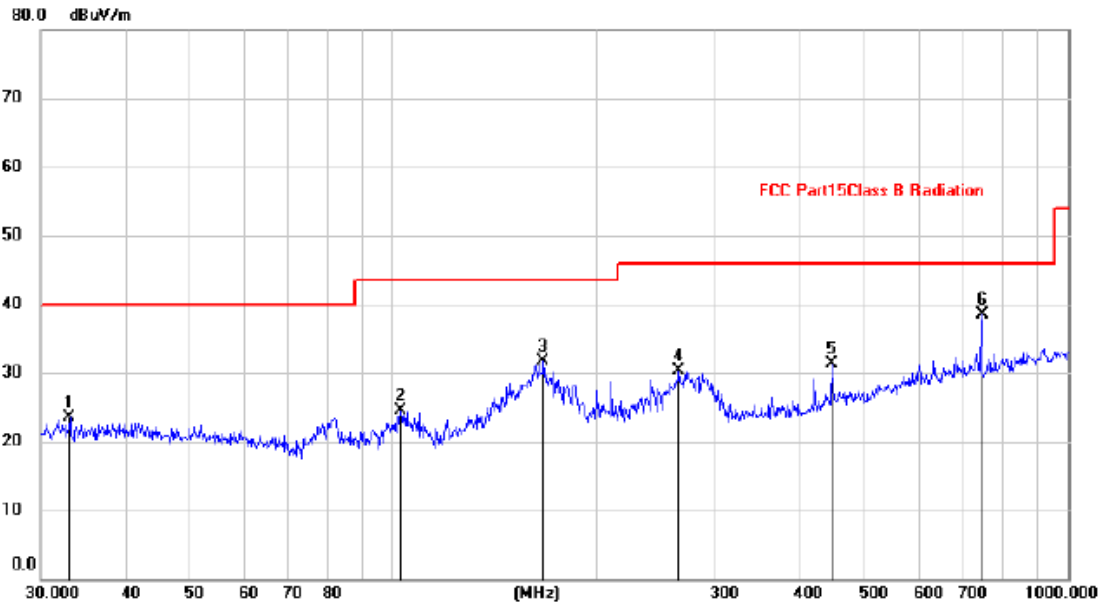

No.	Mk.	Freq.	Reading Level	Correct Factor	Measurement	Limit	Margin	Antenna Height	Table Degree
		MHz	dBuV	dB	dBuV/m	dBuV/m	dB	cm	degree
1		33.0949	10.11	13.44	23.55	40.00	-16.45		
2		102.3597	13.72	10.82	24.54	43.50	-18.96		
3		167.2366	17.74	14.00	31.74	43.50	-11.76		
4		264.7457	17.81	12.55	30.36	46.00	-15.64		
5		446.4141	14.43	16.86	31.29	46.00	-14.71		
6	*	747.4825	17.19	21.27	38.46	46.00	-7.54		

From 1G-25GHz

Test Mode: IEEE 802.11b TX Low (worst case : ANT1)									
Freq (MHz)	Read Level (dBUV/m)	Polar (H/V)	Antenna Factor (dB/m)	Cable loss(dB)	Amp Factor (dB)	Result (dBUV/m)	Limit (dBUV/m)	Margin (dB)	Remark
4824	41.75	V	33.98	10.22	34.25	51.70	74	22.30	PK
4824	32.69	V	33.98	10.22	34.25	42.64	54	11.36	AV
7236	/	/	/	/	/	/	/	/	/
9648	/	/	/	/	/	/	/	/	/
4824	42.75	H	33.98	10.22	34.25	52.70	74	21.30	PK
4824	31.73	H	33.98	10.22	34.25	41.68	54	12.32	AV
7236	/	/	/	/	/	/	/	/	/
9648	/	/	/	/	/	/	/	/	/
Test Mode: IEEE 802.11b TX Mid									
4874	42.20	V	33.98	10.22	34.25	52.15	74	21.85	PK
4874	32.42	V	33.98	10.22	34.25	42.37	54	11.63	AV
7311	/	/	/	/	/	/	/	/	/
9748	/	/	/	/	/	/	/	/	/
4874	42.35	H	33.98	10.22	34.25	52.30	74	21.70	PK
4874	32.24	H	33.98	10.22	34.25	42.19	54	11.81	AV
7311	/	/	/	/	/	/	/	/	/
9748	/	/	/	/	/	/	/	/	/
Test Mode: IEEE 802.11b TX High									
4924	41.89	V	33.98	10.22	34.25	51.84	74	22.16	PK
4924	32.94	V	33.98	10.22	34.25	42.89	54	11.11	AV
7386	/	/	/	/	/	/	/	/	/
9848	/	/	/	/	/	/	/	/	/
4924	42.89	H	33.98	10.22	34.25	52.84	74	21.16	PK
4924	32.07	H	33.98	10.22	34.25	42.02	54	11.98	AV
7386	/	/	/	/	/	/	/	/	/
9848	/	/	/	/	/	/	/	/	/
Note:									
1, Result = Read level + Antenna factor + cable loss-Amp factor									
2, All the other emissions not reported were too low to read and deemed to comply with FCC limit.									

Test Mode: IEEE 802.11g TX Low (worst case : ANT1)									
Freq (MHz)	Read Level (dBuV/m)	Polar (H/V)	Antenna Factor (dB/m)	Cable loss(dB)	Amp Factor (dB)	Result (dBuV/m)	Limit (dBuV/m)	Margin (dB)	Remark
4824	42.31	V	33.98	10.22	34.25	52.26	74	21.74	PK
4824	32.45	V	33.98	10.22	34.25	42.40	54	11.60	AV
7236	/	/	/	/	/	/	/	/	/
9648	/	/	/	/	/	/	/	/	/
4824	42.08	H	33.98	10.22	34.25	52.03	74	21.97	PK
4824	31.39	H	33.98	10.22	34.25	41.34	54	12.66	AV
7236	/	/	/	/	/	/	/	/	/
9648	/	/	/	/	/	/	/	/	/
Test Mode: IEEE 802.11g TX Mid									
4874	42.22	V	33.98	10.22	34.25	52.17	74	21.83	PK
4874	32.40	V	33.98	10.22	34.25	42.35	54	11.65	AV
7311	/	/	/	/	/	/	/	/	/
9748	/	/	/	/	/	/	/	/	/
4874	42.26	H	33.98	10.22	34.25	52.21	74	21.79	PK
4874	31.96	H	33.98	10.22	34.25	41.91	54	12.09	AV
7311	/	/	/	/	/	/	/	/	/
9748	/	/	/	/	/	/	/	/	/
Test Mode: IEEE 802.11g TX High									
4924	43.08	V	33.98	10.22	34.25	53.03	74	20.97	PK
4924	32.70	V	33.98	10.22	34.25	42.65	54	11.35	AV
7386	/	/	/	/	/	/	/	/	/
9848	/	/	/	/	/	/	/	/	/
4924	42.71	H	33.98	10.22	34.25	52.66	74	21.34	PK
4924	32.53	H	33.98	10.22	34.25	42.48	54	11.52	AV
7386	/	/	/	/	/	/	/	/	/
9848	/	/	/	/	/	/	/	/	/
Note:									
1, Result = Read level + Antenna factor + cable loss-Amp factor									
2, All the other emissions not reported were too low to read and deemed to comply with FCC limit.									

Test Mode: IEEE 802.11n HT20 TX Low (ANT1)									
Freq (MHz)	Read Level (dBuV/m)	Polar (H/V)	Antenna Factor (dB/m)	Cable loss(dB)	Amp Factor (dB)	Result (dBuV/m)	Limit (dBuV/m)	Margin (dB)	Remark
4824	43.25	V	33.98	10.22	34.25	53.20	74	20.80	PK
4824	33.04	V	33.98	10.22	34.25	42.99	54	11.01	AV
7236	/	/	/	/	/	/	/	/	/
9648	/	/	/	/	/	/	/	/	/
4824	42.22	H	33.98	10.22	34.25	52.17	74	21.83	PK
4824	32.30	H	33.98	10.22	34.25	42.25	54	11.75	AV
7236	/	/	/	/	/	/	/	/	/
9648	/	/	/	/	/	/	/	/	/
Test Mode: IEEE 802.11n HT20 TX Mid (ANT1)									
4874	43.23	V	33.98	10.22	34.25	53.18	74	20.82	PK
4874	33.14	V	33.98	10.22	34.25	43.09	54	10.91	AV
7311	/	/	/	/	/	/	/	/	/
9748	/	/	/	/	/	/	/	/	/
4874	43.24	H	33.98	10.22	34.25	53.19	74	20.81	PK
4874	31.79	H	33.98	10.22	34.25	41.74	54	12.26	AV
7311	/	/	/	/	/	/	/	/	/
9748	/	/	/	/	/	/	/	/	/
Test Mode: IEEE 802.11n HT20 TX High (ANT1)									
4924	42.15	V	33.98	10.22	34.25	52.10	74	21.90	PK
4924	32.91	V	33.98	10.22	34.25	42.86	54	11.14	AV
7386	/	/	/	/	/	/	/	/	/
9848	/	/	/	/	/	/	/	/	/
4924	42.97	H	33.98	10.22	34.25	52.92	74	21.08	PK
4924	32.80	H	33.98	10.22	34.25	42.75	54	11.25	AV
7386	/	/	/	/	/	/	/	/	/
9848	/	/	/	/	/	/	/	/	/
Note:									
1, Result = Read level + Antenna factor + cable loss-Amp factor									
2, All the other emissions not reported were too low to read and deemed to comply with FCC limit.									

Test Mode: IEEE 802.11n HT40 TX Low (ANT1)									
Freq (MHz)	Read Level (dBuV/m)	Polar (H/V)	Antenna Factor (dB/m)	Cable loss(dB)	Amp Factor (dB)	Result (dBuV/m)	Limit (dBuV/m)	Margin (dB)	Remark
4844	41.85	V	33.98	10.22	34.25	51.80	74	22.20	PK
4844	32.87	V	33.98	10.22	34.25	42.82	54	11.18	AV
7266	/	/	/	/	/	/	/	/	/
9688	/	/	/	/	/	/	/	/	/
4844	42.44	H	33.98	10.22	34.25	52.39	74	21.61	PK
4844	31.41	H	33.98	10.22	34.25	41.36	54	12.64	AV
7266	/	/	/	/	/	/	/	/	/
9688	/	/	/	/	/	/	/	/	/
Test Mode: IEEE 802.11n HT40 TX Mid (ANT1)									
4874	42.20	V	33.98	10.22	34.25	52.15	74	21.85	PK
4874	33.09	V	33.98	10.22	34.25	43.04	54	10.96	AV
7311	/	/	/	/	/	/	/	/	/
9748	/	/	/	/	/	/	/	/	/
4874	42.85	H	33.98	10.22	34.25	52.80	74	21.20	PK
4874	31.66	H	33.98	10.22	34.25	41.61	54	12.39	AV
7311	/	/	/	/	/	/	/	/	/
9748	/	/	/	/	/	/	/	/	/
Test Mode: IEEE 802.11n HT40 TX High (ANT1)									
4904	42.52	V	33.98	10.22	34.25	52.47	74	21.53	PK
4904	33.15	V	33.98	10.22	34.25	43.10	54	10.90	AV
7356	/	/	/	/	/	/	/	/	/
9808	/	/	/	/	/	/	/	/	/
4904	42.40	H	33.98	10.22	34.25	52.35	74	21.65	PK
4904	32.16	H	33.98	10.22	34.25	42.11	54	11.89	AV
7356	/	/	/	/	/	/	/	/	/
9808	/	/	/	/	/	/	/	/	/
Note:									
1, Result = Read level + Antenna factor + cable loss-Amp factor									
2, All the other emissions not reported were too low to read and deemed to comply with FCC limit.									

Note: All models have been tested to reflect the data of the worst models.

## 4. POWER LINE CONDUCTED EMISSION

### 4.1. Test Limits

Frequency MHz	Limits dB( $\mu$ V)	
	Quasi-peak Level	Average Level
0.15 -0.50	66 -56*	56 - 46*
0.50 -5.00	56	46
5.00 -30.00	60	50

- Notes: 1. \*Decreasing linearly with logarithm of frequency.  
 2. The lower limit shall apply at the transition frequencies.  
 3. The limit decreases in line with the logarithm of the frequency in the rang of 0.15 to 0.50 MHz.

### 4.2. Test Procedure

The EUT is put on the plane 0.8m high above the ground by insulating support and is connected to the power mains through a line impedance stabilization network (L.I.S.N.). This provides a 50ohm coupling impedance for the EUT system. Please refer the block diagram of the test setup and photographs. Both sides of AC lines are checked to find out the maximum conducted emission. In order to find the maximum emission levels, the relative positions of equipment and all of the interface cables shall be changed according to ANSI C63.10:2013 on Conducted Emission Measurement.

The bandwidth of test receiver is set at 9 kHz.

### 4.3. Test Setup

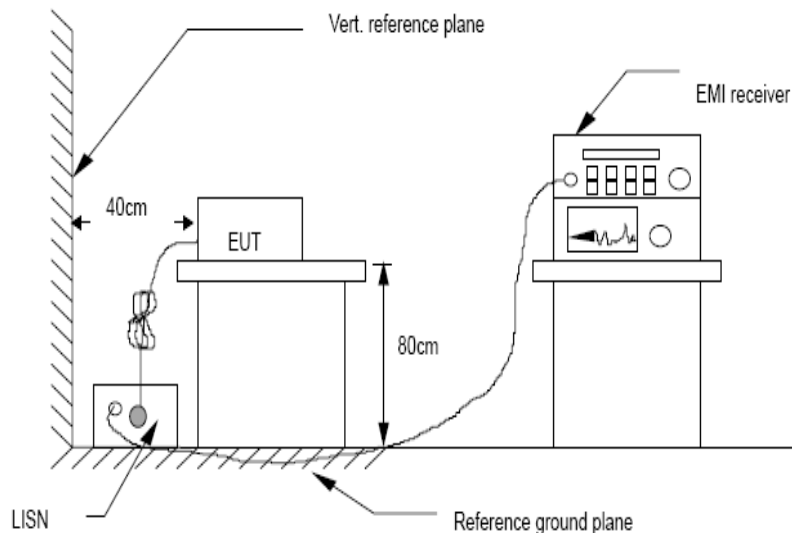

### 4.4. Test Results

Test result for 802.11n HT40 (High Channel: ANT1), AC 120V/ 60Hz

Line:

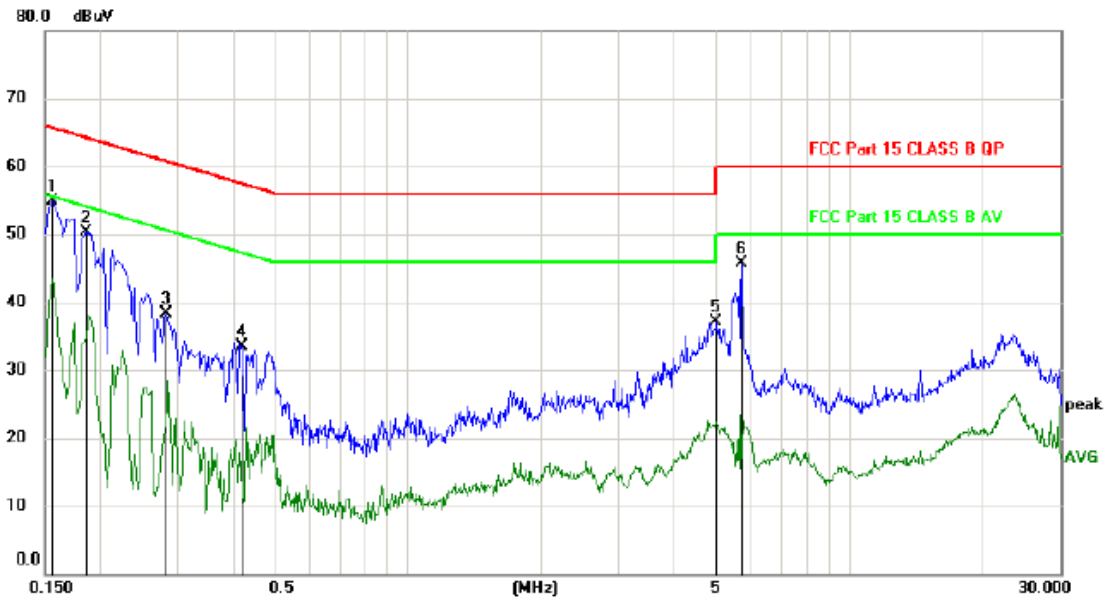

No.	Mk.	Freq. MHz	Reading Level dBuV	Correct Factor dB	Measure- ment dBuV	Limit dBuV	Margin dB	Detector	Comment
1	*	0.1560	45.35	9.63	54.98	65.67	-10.69	peak	
2		0.1860	40.61	9.64	50.25	64.21	-13.96	peak	
3		0.2819	28.73	9.66	38.39	60.76	-22.37	peak	
4		0.4200	23.80	9.68	33.48	57.45	-23.97	peak	
5		4.9860	26.96	10.06	37.02	56.00	-18.98	peak	
6		5.6880	35.70	10.10	45.80	60.00	-14.20	peak	

Neutral:

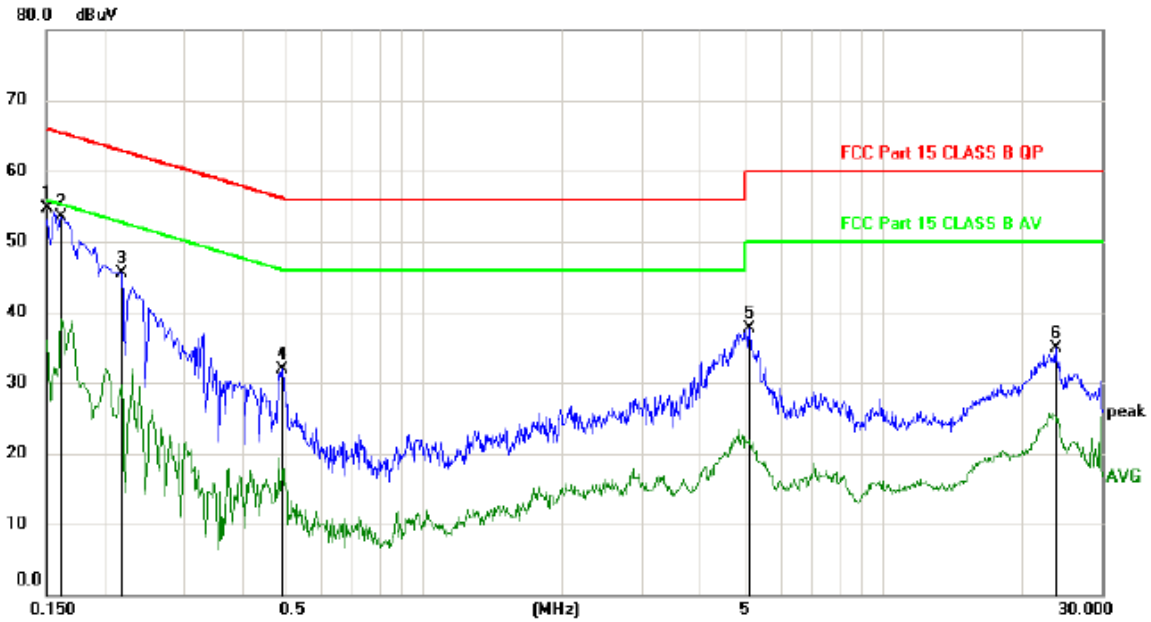

No.	Mk.	Freq. MHz	Reading Level dBuV	Correct Factor dB	Measure- ment dBuV	Limit dBuV	Margin dB	Detector	Comment
1	*	0.1500	45.07	9.63	54.70	66.00	-11.30	peak	
2		0.1620	43.96	9.63	53.59	65.36	-11.77	peak	
3		0.2190	35.76	9.65	45.41	62.86	-17.45	peak	
4		0.4890	22.20	9.68	31.88	56.18	-24.30	peak	
5		5.1330	27.56	10.07	37.63	60.00	-22.37	peak	
6		23.7780	24.71	10.26	34.97	60.00	-25.03	peak	

Note: All models have been tested to reflect the data of the worst models.



## 5. CONDUCTED MAXIMUM OUTPUT POWER

### 5.1. Test limits

Please refer section 15.247.

Regulation 15.247(b) The limit of Maximum Peak Output Power Measurement is 1 W(30dBm)

### 5.2. Test Procedure

Details see the KDB558074 D01 Meas Guidance V05R01

5.2.1 Place the EUT on the table and set it in transmitting mode.

5.2.2 Connected the EUT's antenna port to peak power meter by 20dB attenuator.

5.2.3 Measure out each mode and each bands peak output power of EUT.

Note: The cable loss and attenuator loss were offset into measure device as amplitude offset.

### 5.3. Test Setup

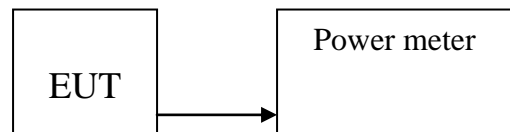

### 5.4. Test Results

PASS

Detailed information please see the following page.

Mode	Frequency (MHz)	PK Output power(dBm)	Limit (dBm)	Result
		ANT1		
IEEE 802.11 b	CH1: 2412	<b>19.811</b>	30	PASS
	CH6: 2437	19.194	30	PASS
	CH11: 2462	18.394	30	PASS
IEEE 802.11 g	CH1: 2412	16.548	30	PASS
	CH6: 2437	18.695	30	PASS
	CH11: 2462	18.228	30	PASS
IEEE 802.11 n/HT20	CH1: 2412	16.728	30	PASS
	CH6: 2437	17.233	30	PASS
	CH11: 2462	16.965	30	PASS
IEEE 802.11 n/HT40	CH3: 2422	16.707	30	PASS
	CH6: 2437	17.382	30	PASS
	CH9: 2452	17.36	30	PASS

## 6. PEAK POWER SPECTRAL DENSITY

### 6.1. Test limits

6.1.1 Please refer section 15.247.

6.1.2 For direct sequence systems, the peak power spectral density conducted from the intentional radiator to the antenna shall not be greater than 8dBm in any 3kHz band during any time interval of continuous transmission.

6.1.3 The direct sequence operating of the hybrid system, with the frequency hopping operation turned off, shall comply with the power density requirements of paragraph (d) of this section.

### 6.2. Test Procedure

Details see the KDB558074 D01 Meas Guidance V05R01

6.2.1 Place the EUT on the table and set it in transmitting mode.

6.2.2 Remove the antenna from the EUT and then connect a low loss RF cable from the antenna port to the spectrum analyzer.

6.2.3 Set the spectrum analyzer as  $RBW = 3\text{kHz}$  (Set the RBW to:  $3\text{ kHz} \leq RBW \leq 100\text{ kHz}$ ),  $VBW = 10\text{kHz}$  (Set the  $VBW \geq 3 \times RBW$ ),  $\text{span} = 1.5 \times \text{DTS bandwidth}$ ., detail see the test plot.

6.2.4 Record the max reading.

6.2.5 Repeat the above procedure until the measurements for all frequencies are completed.

### 6.3. Test Setup

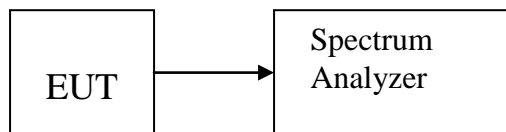

## 6.4. Test Results

Mode	Frequency (MHz)	Power Spectral Density (dBm)	Limit (dBm)	Result
		ANT1		
IEEE 802.11 b	Lowest	-7.958	8	PASS
	Middle	-7.692	8	PASS
	Highest	-7.206	8	PASS
IEEE 802.11 g	Lowest	-8.387	8	PASS
	Middle	-7.151	8	PASS
	Highest	-6.59	8	PASS
IEEE 802.11 n/HT20	Lowest	-8.324	8	PASS
	Middle	-6.431	8	PASS
	Highest	-7.226	8	PASS
IEEE 802.11 n/HT40	Lowest	-15.360	8	PASS
	Middle	-15.933	8	PASS
	Highest	-17.227	8	PASS

PSD NVNT 802.11b 2412MHz Ant1



PSD NVNT 802.11b 2437MHz Ant1



PSD NVNT 802.11b 2462MHz Ant1



PSD NVNT 802.11g 2412MHz Ant1

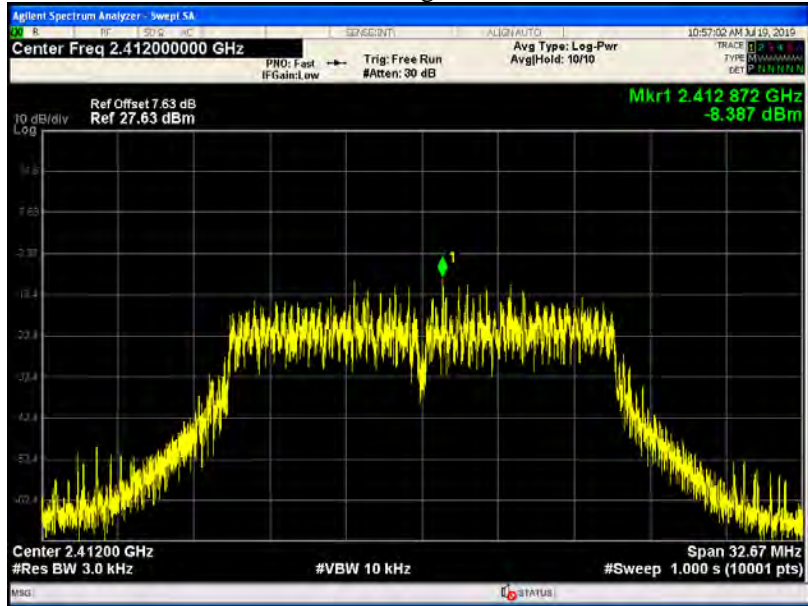

PSD NVNT 802.11g 2437MHz Ant1

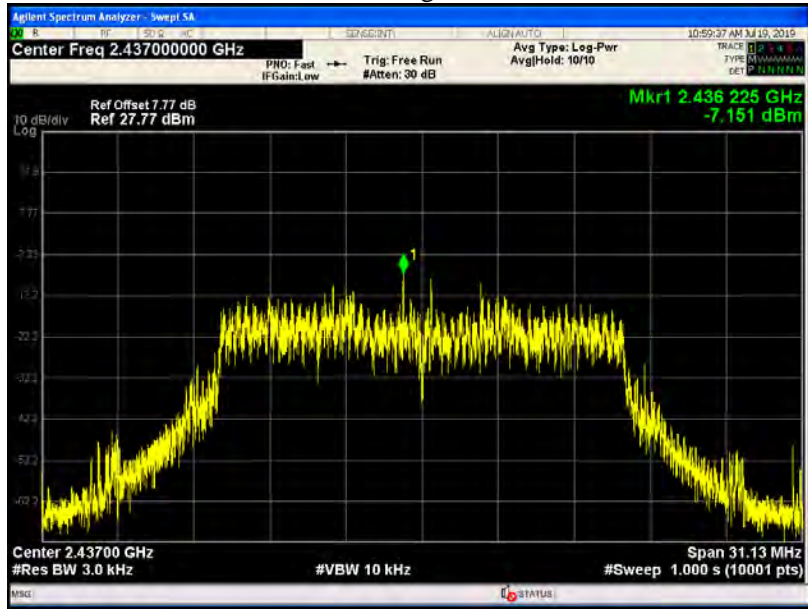

PSD NVNT 802.11g 2462MHz Ant1

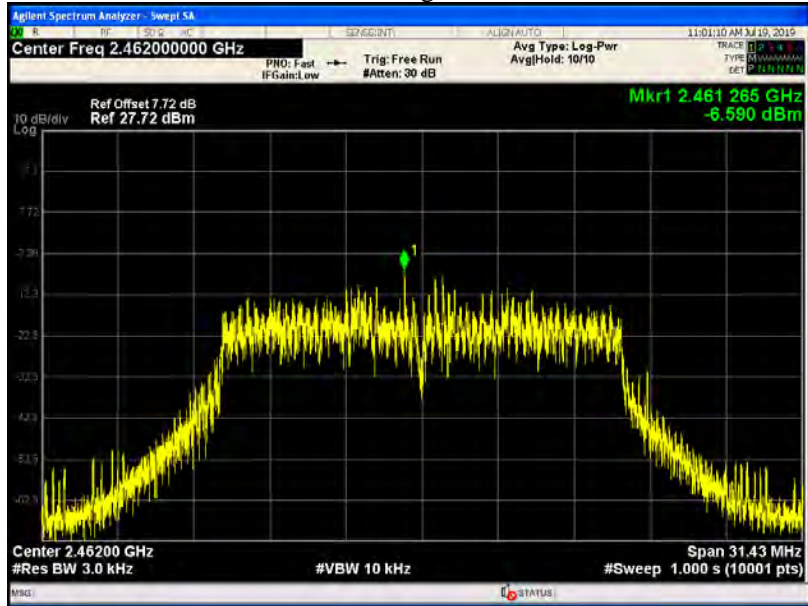

PSD NVNT 802.11n(HT20) 2412MHz Ant1

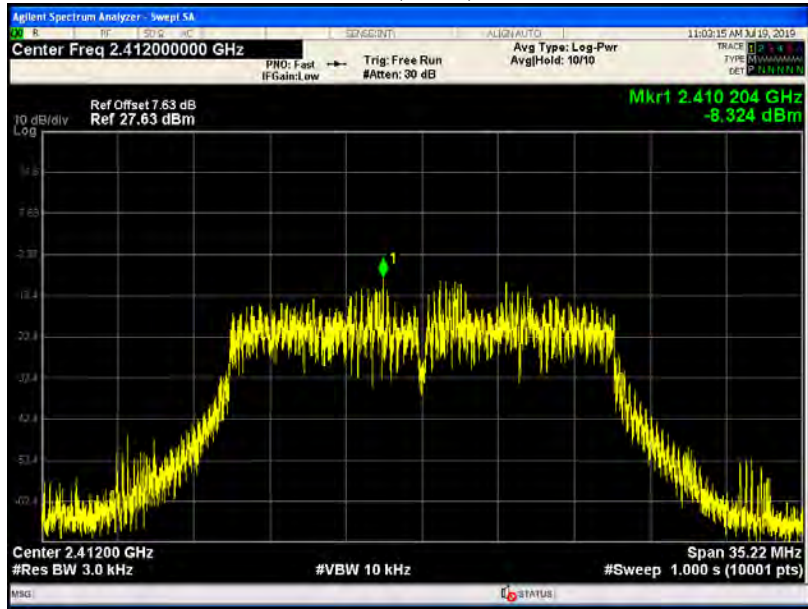

PSD NVNT 802.11n(HT20) 2437MHz Ant1

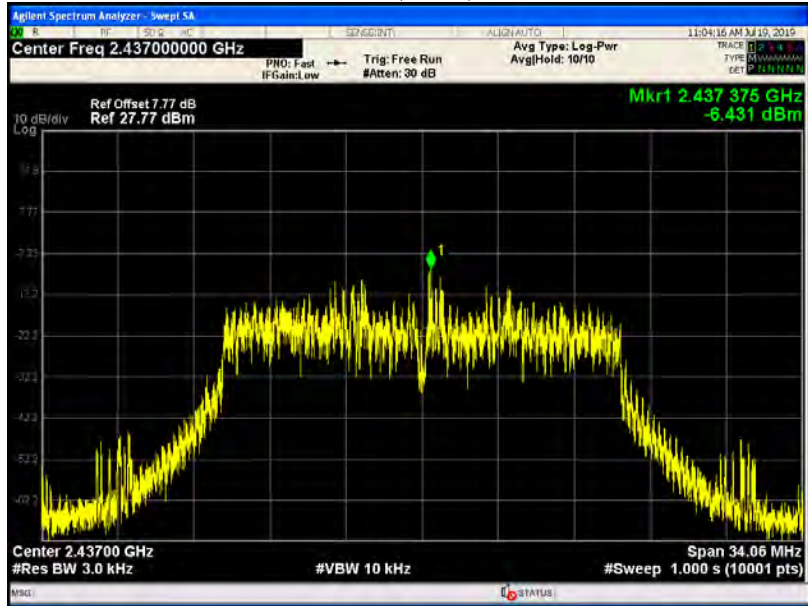



PSD NVNT 802.11n(HT20) 2462MHz Ant1

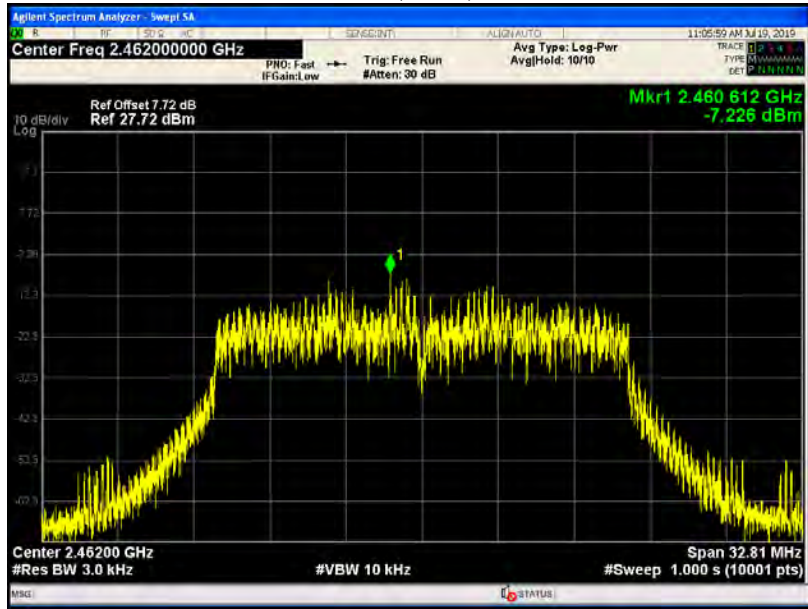

PSD NVNT 802.11n(HT40) 2422MHz Ant1

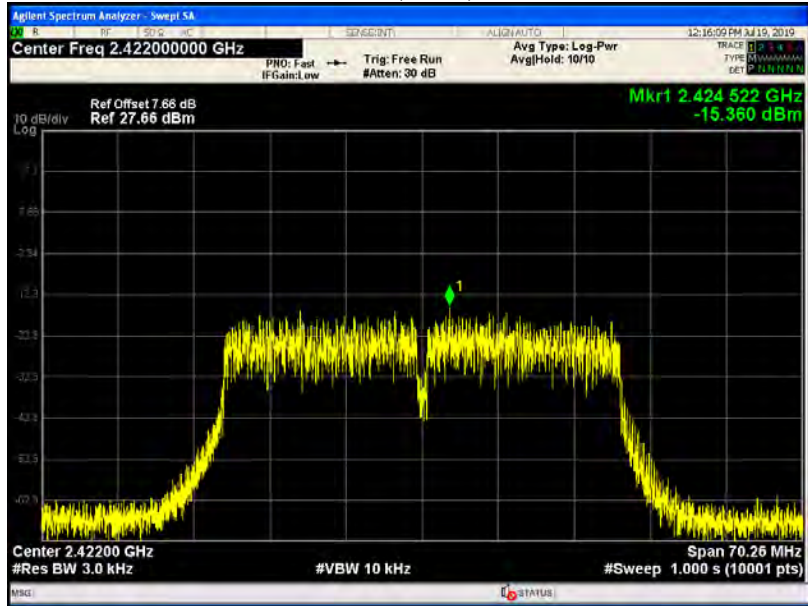

PSD NVNT 802.11n(HT40) 2437MHz Ant1

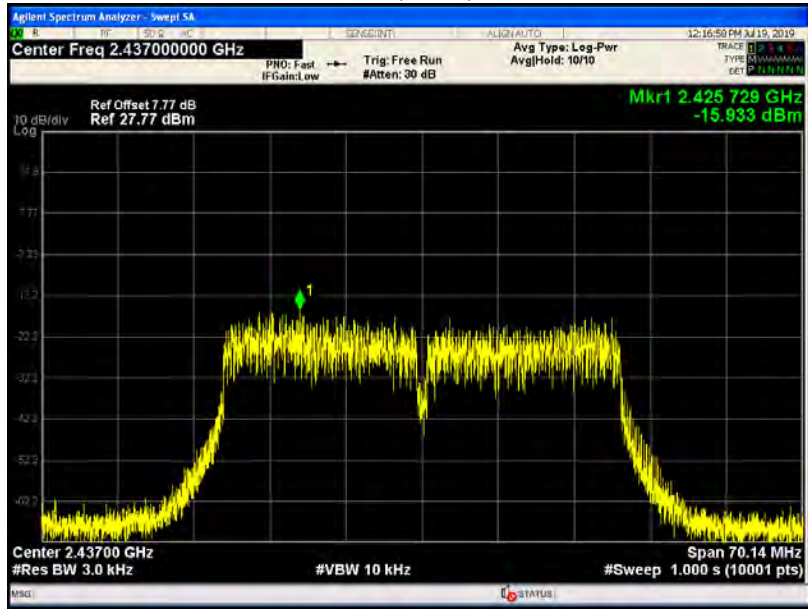

PSD NVNT 802.11n(HT40) 2452MHz Ant1

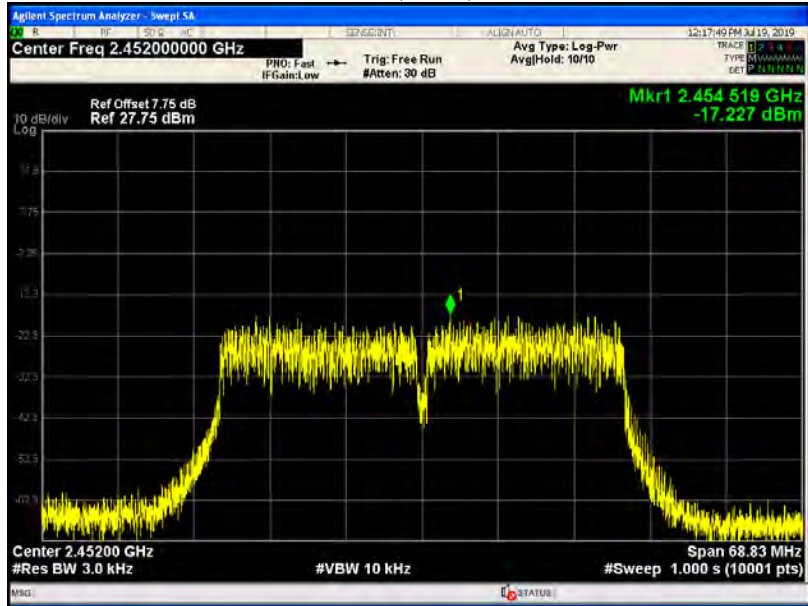

## 7. BANDWIDTH

### 7.1. Test limits

Please refer section 15.247

For direct sequence systems, the minimum 6dB bandwidth shall be at least 500 kHz.

### 7.2. Test Procedure

Details see the KDB558074 D01 Meas Guidance V05R01

- a) The bandwidth is measured at an amplitude level reduced 6dB from the reference level. The reference level is the level of the highest amplitude signal observed from the transmitter at the fundamental frequency. Once the reference level is established, the equipment is conditioned with typical modulating signal to produce the worst-case (i.e. the widest) bandwidth.
- b) The test receiver set RBW = 100kHz, VBW  $\geq 3 \times$  RBW = 300kHz, Peak Detector, Sweep time set auto, detail see the test plot.

### 7.3. Test Setup

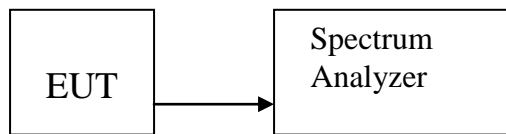

### 7.4. Test Results

Mode	Frequency (MHz)	Antenna	99% OBW (MHz)	-6 dB Bandwidth (MHz)	Limit -6 dB Bandwidth (MHz)	Verdict
802.11b	2412	Ant 1	15.0286	11.1304	0.5	Pass
802.11b	2437	Ant 1	14.681	10.6153	0.5	Pass
802.11b	2462	Ant 1	14.7724	9.9974	0.5	Pass
802.11g	2412	Ant 1	16.4131	16.2963	0.5	Pass
802.11g	2437	Ant 1	16.3537	16.0425	0.5	Pass
802.11g	2462	Ant 1	16.423	16.2789	0.5	Pass
802.11n(HT20)	2412	Ant 1	17.6085	17.6364	0.5	Pass
802.11n(HT20)	2437	Ant 1	17.5327	16.9082	0.5	Pass
802.11n(HT20)	2462	Ant 1	17.5471	16.9524	0.5	Pass
802.11n(HT40)	2422	Ant 1	35.7629	35.0415	0.5	Pass
802.11n(HT40)	2437	Ant 1	36.0234	35.0335	0.5	Pass
802.11n(HT40)	2452	Ant 1	36.0751	34.7349	0.5	Pass

OBW NVNT 802.11b 2412MHz Ant1

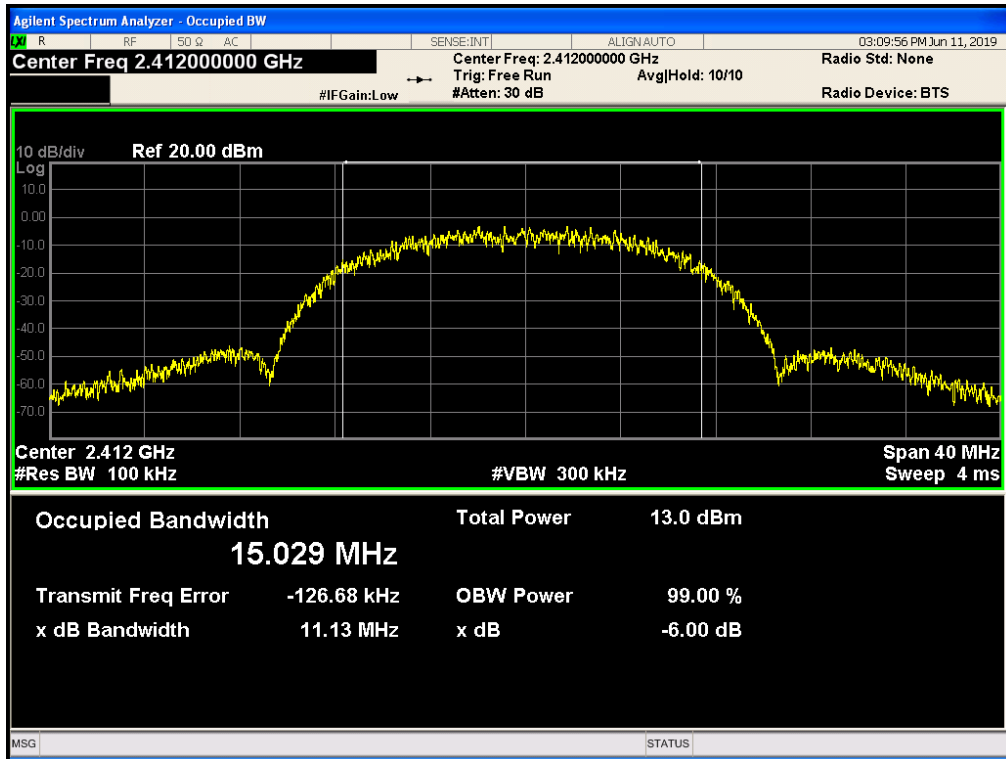

OBW NVNT 802.11b 2437MHz Ant1

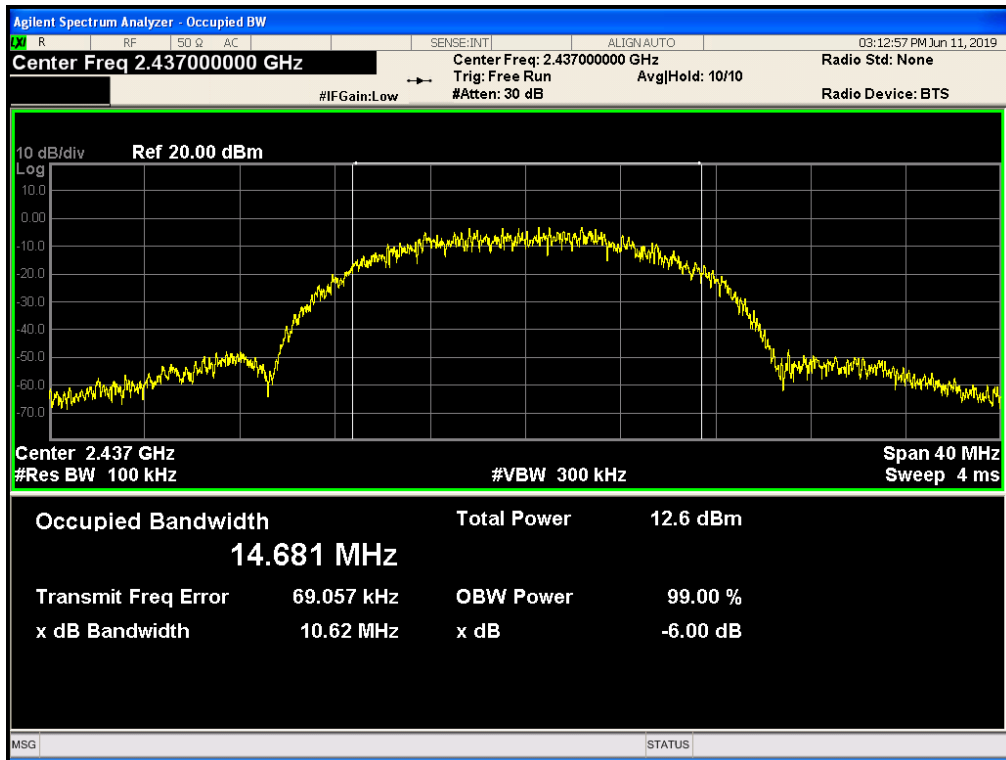

OBW NVNT 802.11b 2462MHz Ant1

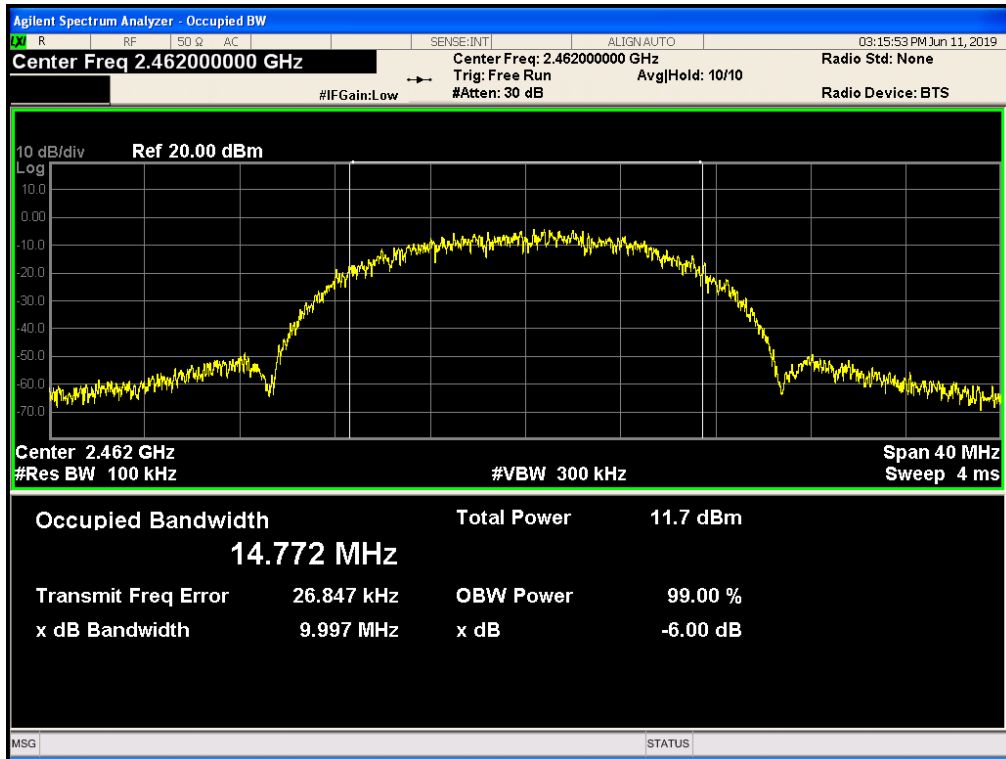

OBW NVNT 802.11g 2412MHz Ant1

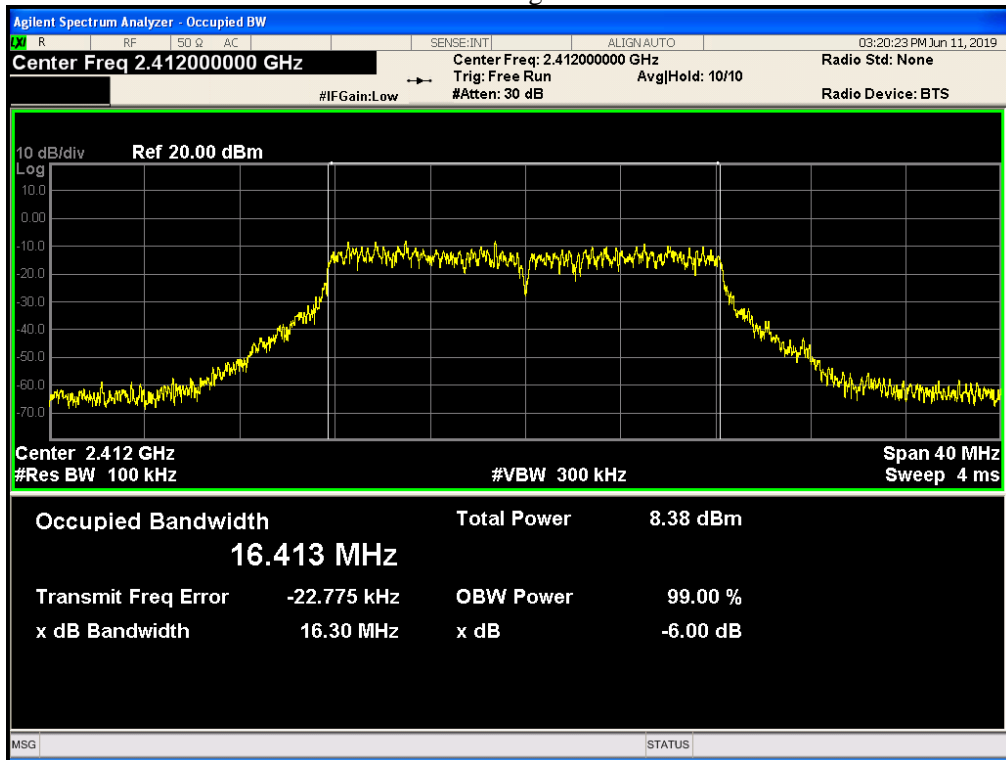

OBW NVNT 802.11g 2437MHz Ant1

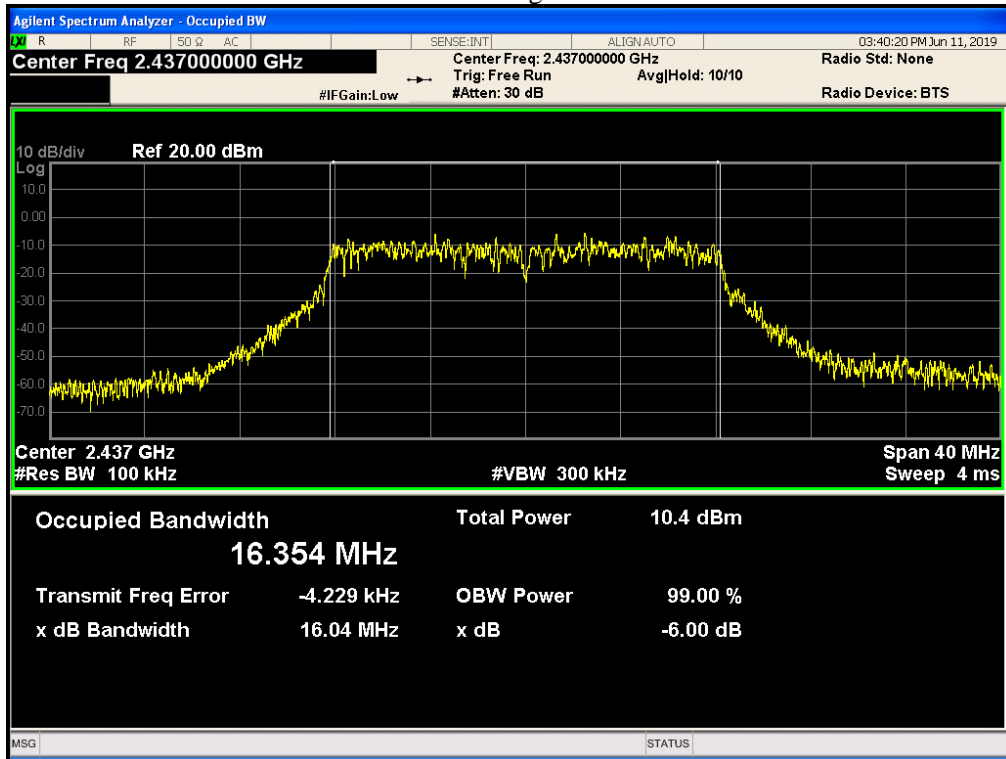

OBW NVNT 802.11g 2462MHz Ant1

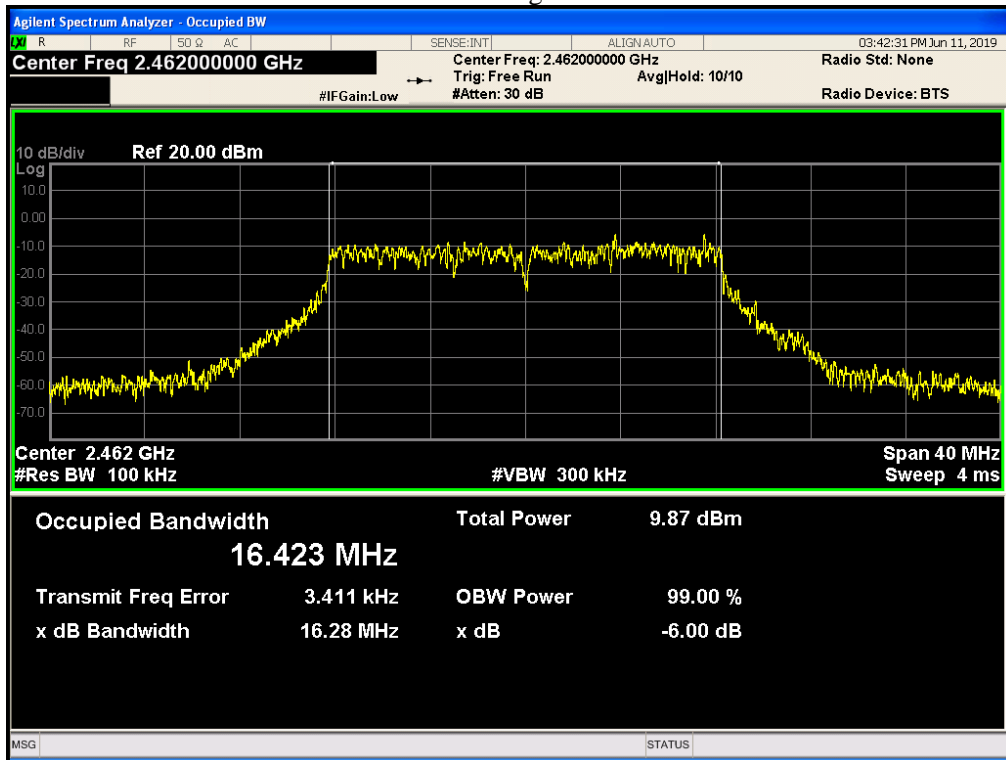

OBW NVNT 802.11n(HT20) 2412MHz Ant1

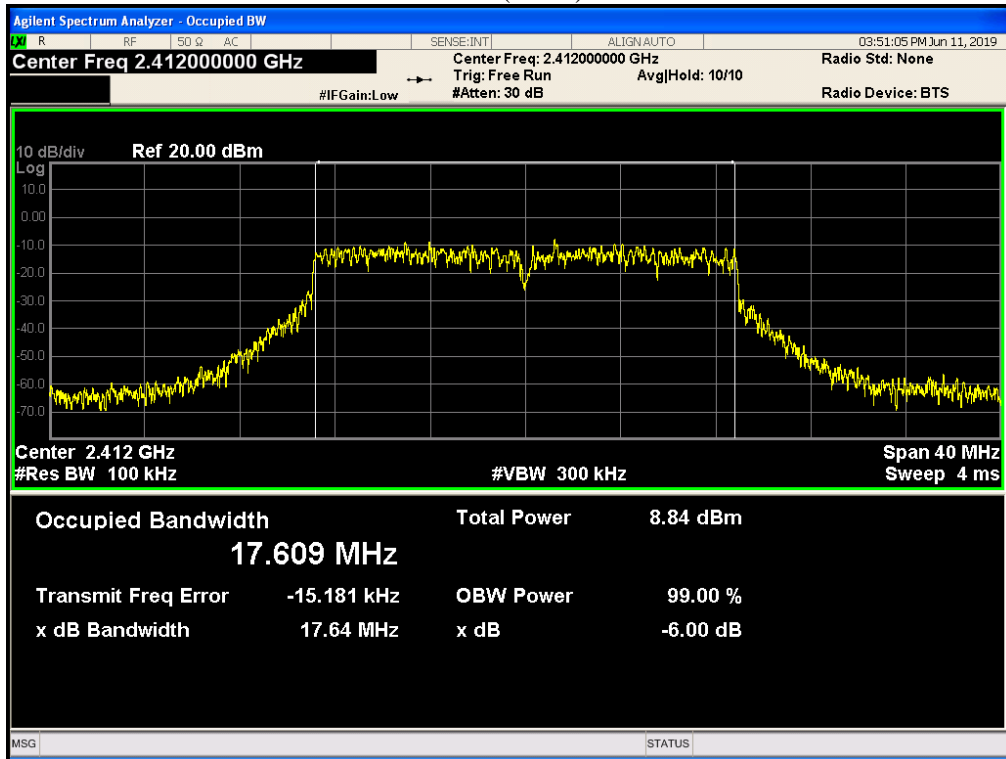

OBW NVNT 802.11n(HT20) 2437MHz Ant1

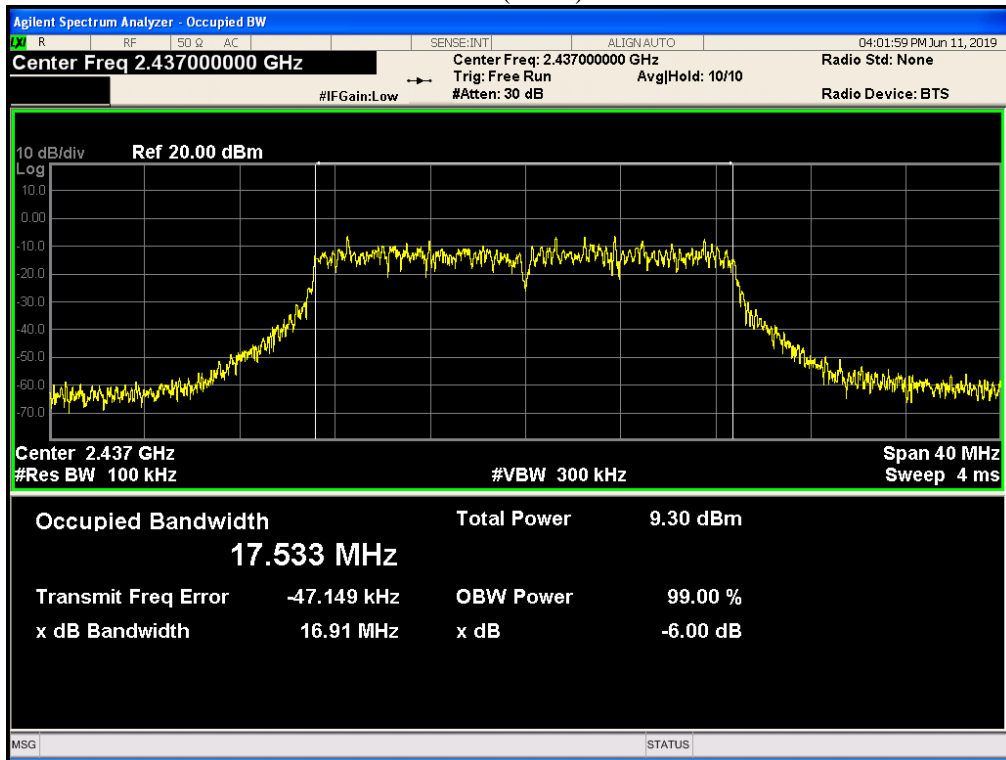

OBW NVNT 802.11n(HT20) 2462MHz Ant1

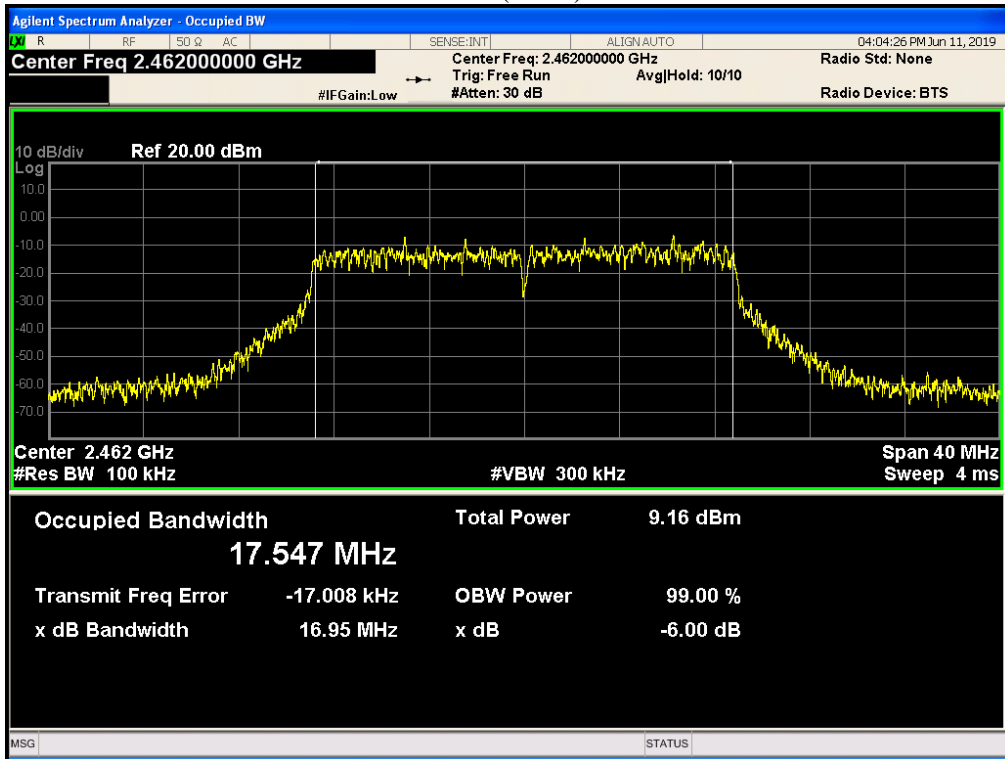

OBW NVNT 802.11n(HT40) 2422MHz Ant1

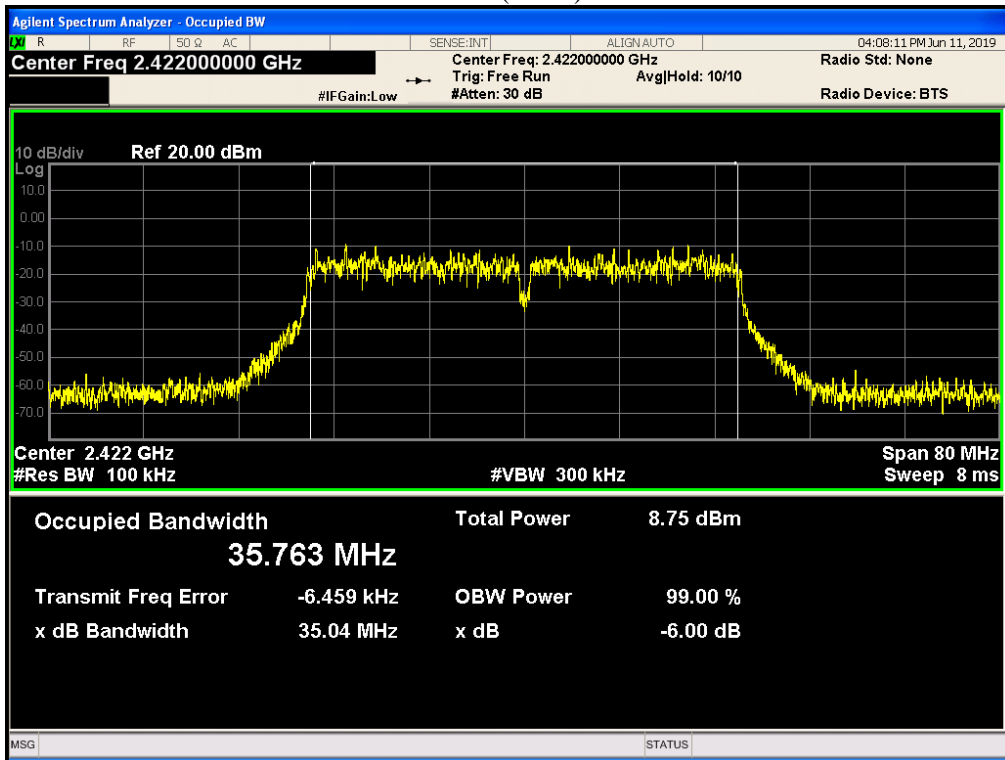



OBW NVNT 802.11n(HT40) 2437MHz Ant1

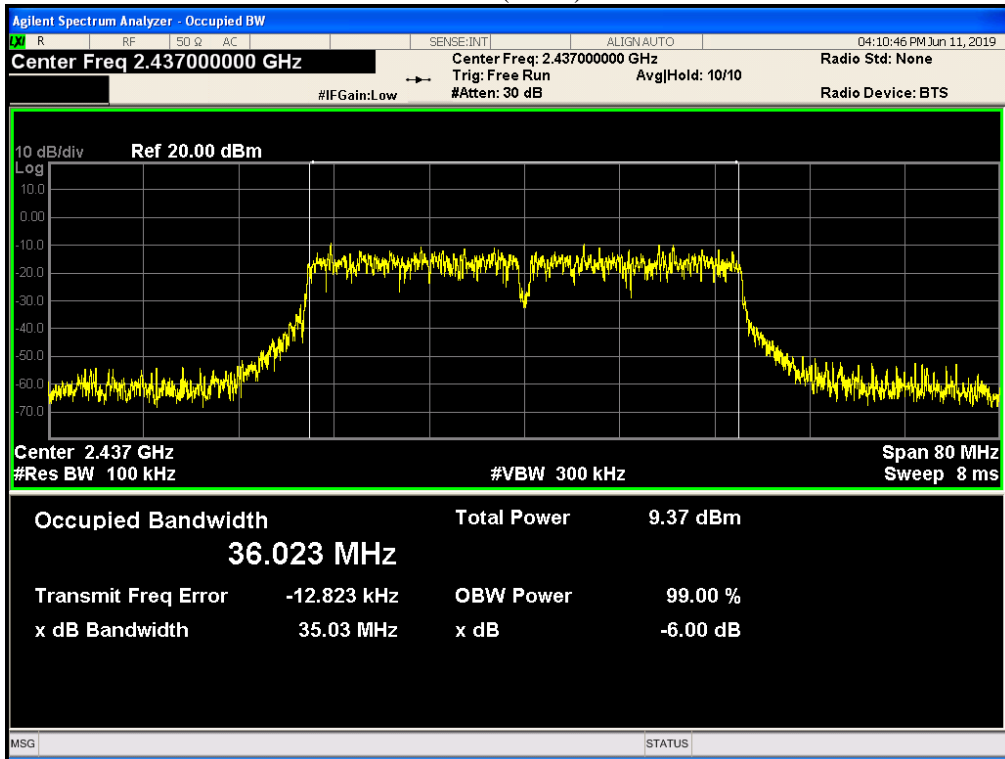

OBW NVNT 802.11n(HT40) 2452MHz Ant1

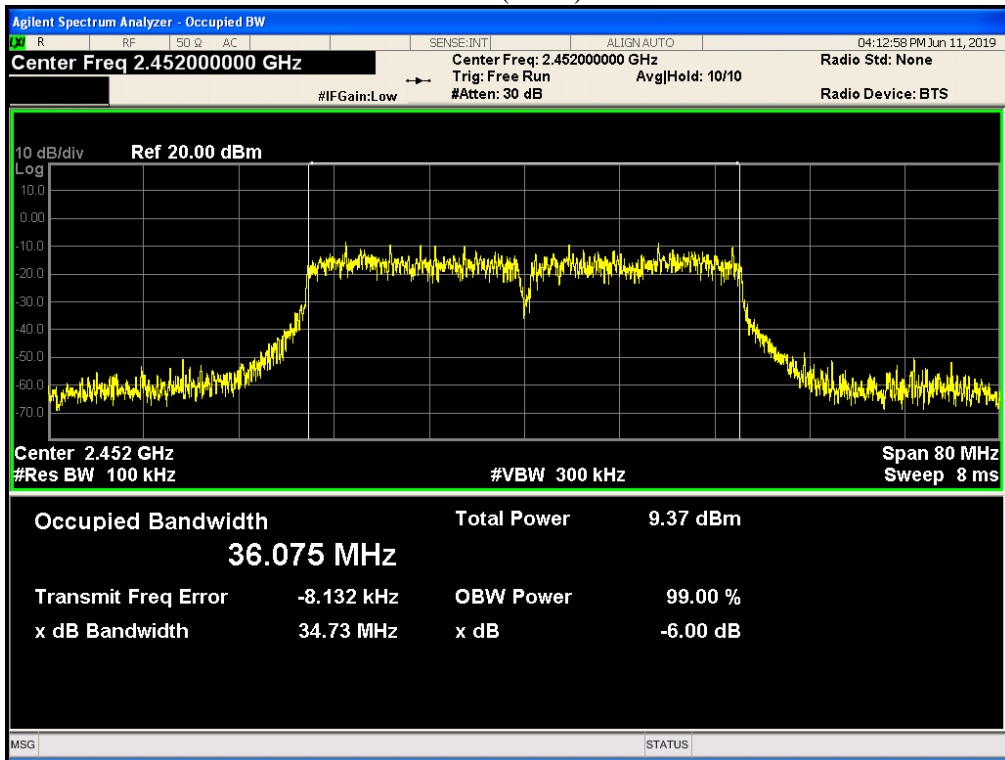

## 8. BAND EDGE CHECK

### 8.1. Test limits

Please refer section 15.247

All the lower and upper band-edges emissions appearing within 2310MHz to 2390MHz and 2483.5MHz to 2500MHz restricted frequency bands shall not exceed the limits shown in 15.209, all the other emissions outside operation frequency band 2400MHz to 2483.5MHz and 5725MHz to 5850MHz shall be at least 20dB below the fundamental emissions, or comply with 15.209 limits.

### 8.2. Test Procedure

Details see the KDB558074 D01 Meas Guidance V05R01

8.2.1 Put the EUT on a 1.5m high table, power on the EUT. Emissions were scanned and measured rotating the EUT to 360 degrees, Find the maximum Emission

8.2.2 Check the spurious emissions out of band.

8.2.3 RBW 1MHz, VBW 3MHz, peak detector for peak value , RBW 1MHz ,VBW 10Hz , RMS detector for AV value.

### 8.3. Test Setup

Same as 5.2.2.

### 8.4. Test Results

PASS.

Detailed information please see the following page.

.

Worst case : ANT1

Test Mode: IEEE 802.11b-Low

Polarization: Vertical

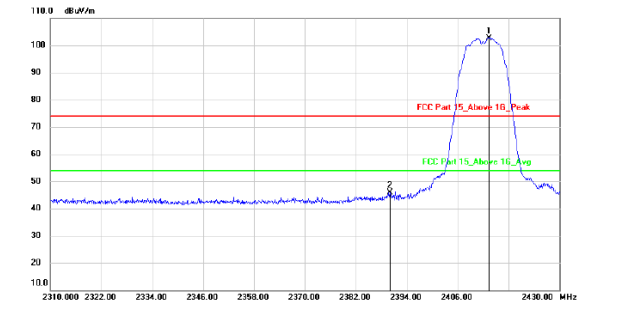

No.	Mk.	Freq.	Reading Level	Correct Factor	Measurement	Limit	Margin	Antenna Height	Table Degree	Comment
		MHz	dBuV	dB	dBuV/m	dBuV/m	dB	cm	degree	
1	*	2413.440	106.16	-3.41	102.75	74.00	28.75	peak		
2		2390.000	49.27	-3.40	45.87	74.00	-28.13	peak		

Polarization: Horizontal

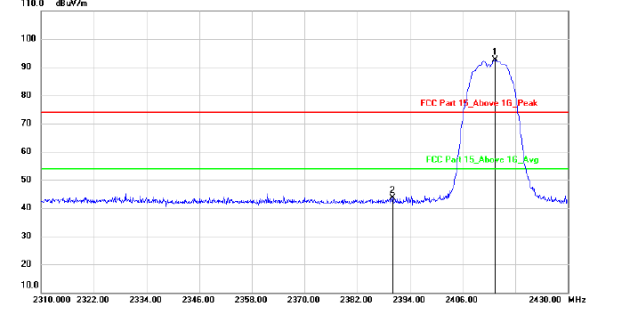

No.	Mk.	Freq.	Reading Level	Correct Factor	Measurement	Limit	Margin	Antenna Height	Table Degree	Comment
		MHz	dBuV	dB	dBuV/m	dBuV/m	dB	cm	degree	
1	*	2413.440	95.96	-3.41	92.55	74.00	18.55	peak		
2		2390.000	46.97	-3.40	43.57	74.00	-30.43	peak		

Test Mode: IEEE 802.11b-High

Polarization: Vertical

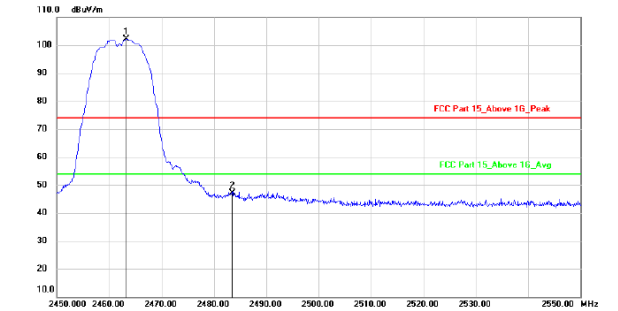

No.	Mk.	Freq.	Reading Level	Correct Factor	Measurement	Limit	Margin	Antenna Height	Table Degree	Comment
		MHz	dBuV	dB	dBuV/m	dBuV/m	dB	cm	degree	
1	*	2463.300	105.53	-3.40	102.13	74.00	28.13	peak		
2		2483.500	50.52	-3.38	47.14	74.00	-26.86	peak		

Polarization: Horizontal

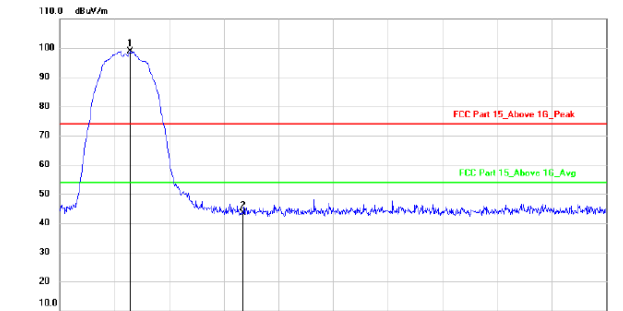

No.	Mk.	Freq.	Reading Level	Correct Factor	Measurement	Limit	Margin	Antenna Height	Table Degree	Comment
		MHz	dBuV	dB	dBuV/m	dBuV/m	dB	cm	degree	
1	*	2462.900	102.25	-3.40	98.85	74.00	24.85	peak		
2		2483.500	46.79	-3.38	43.41	74.00	-30.59	peak		

Worst case : ANT1

Test Mode: IEEE 802.11g-Low

Polarization: Vertical

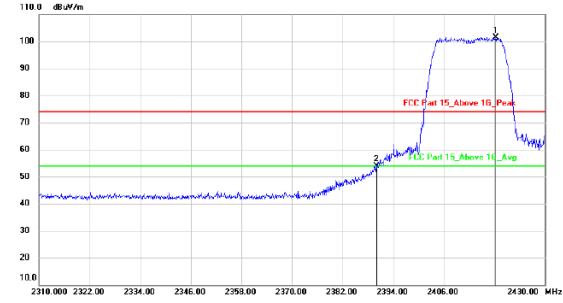

No. Mk.	Freq.	Reading Level	Correct Factor	Measurement	Limit	Margin	Antenna Height	Table Degree	Comment
	MHz	dBuV	dB	dBuV/m	dBuV/m	dB	cm	degree	
1 *	2418.360	104.88	-3.41	101.47	74.00	27.47	peak		
2	2390.000	57.37	-3.40	53.97	74.00	-20.03	peak		

Polarization: Horizontal

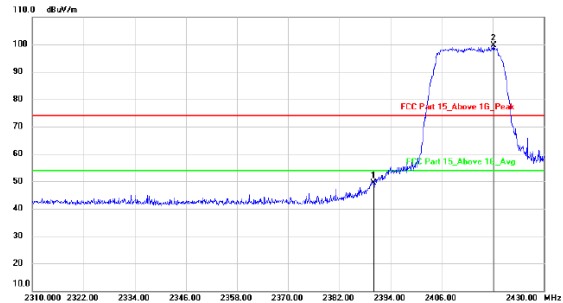

No. Mk.	Freq.	Reading Level	Correct Factor	Measurement	Limit	Margin	Antenna Height	Table Degree	Comment
	MHz	dBuV	dB	dBuV/m	dBuV/m	dB	cm	degree	
1	2390.000	52.74	-3.40	49.34	74.00	-24.66	peak		
2 *	2418.240	103.09	-3.41	99.68	74.00	25.68	peak		

Test Mode: IEEE 802.11g-High

Polarization: Vertical

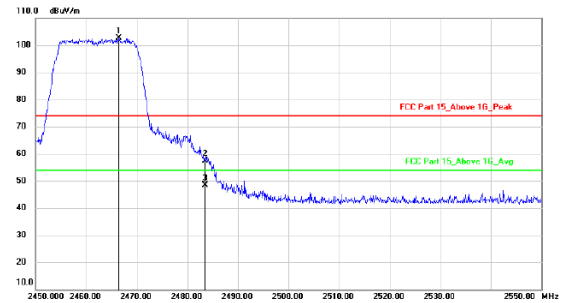

No. Mk.	Freq.	Reading Level	Correct Factor	Measurement	Limit	Margin	Antenna Height	Table Degree	Comment
	MHz	dBuV	dB	dBuV/m	dBuV/m	dB	cm	degree	
1 *	2466.500	106.03	-3.39	102.64	74.00	28.64	peak		
2	2483.500	60.69	-3.38	57.31	74.00	-16.69	peak		
3	2483.500	51.74	-3.38	48.36	54.00	-5.64	AVG		

Polarization: Horizontal

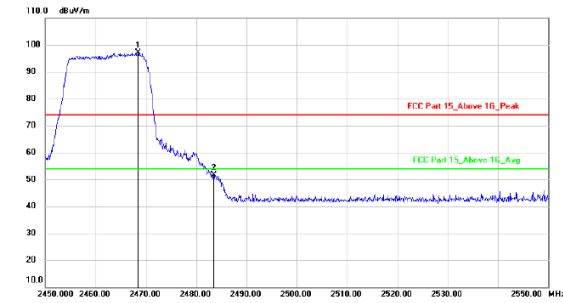

No. Mk.	Freq.	Reading Level	Correct Factor	Measurement	Limit	Margin	Antenna Height	Table Degree	Comment
	MHz	dBuV	dB	dBuV/m	dBuV/m	dB	cm	degree	
1 *	2468.500	100.58	-3.39	97.19	74.00	23.19	peak		
2	2483.500	55.04	-3.38	51.66	74.00	-22.34	peak		

Test Mode: IEEE 802.11n(HT20)-Low  
Polarization: Vertical

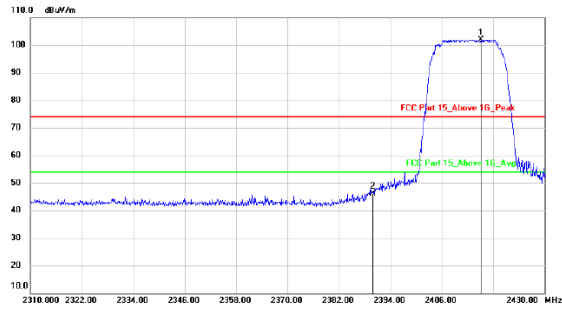

No.	Mk.	Freq.	Reading Level	Correct Factor	Measurement	Limit	Margin	Antenna Height	Table Degree	Comment
		MHz	dBuV	dB	dBuV/m	dBuV/m	dB	Detector	cm	degree
1	*	2415.120	105.41	-3.41	102.00	74.00	28.00	peak		
2		2390.000	49.42	-3.40	46.02	74.00	-27.98	peak		

Polarization: Horizontal

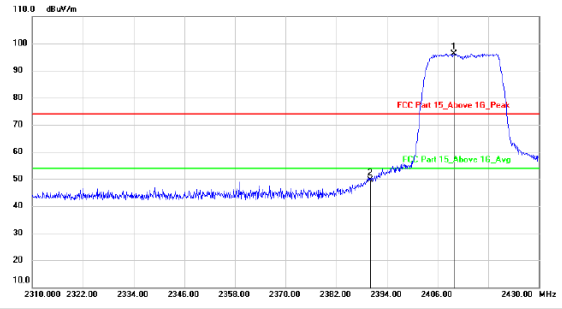

No.	Mk.	Freq.	Reading Level	Correct Factor	Measurement	Limit	Margin	Antenna Height	Table Degree	Comment
		MHz	dBuV	dB	dBuV/m	dBuV/m	dB	Detector	cm	degree
1	*	2409.960	99.59	-3.40	96.19	74.00	22.19	peak		
2		2390.000	53.08	-3.40	49.68	74.00	-24.32	peak		

Test Mode: IEEE 802.11n(HT20)-High  
Polarization: Vertical

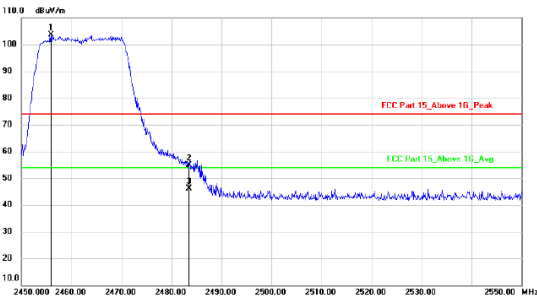

No.	Mk.	Freq.	Reading Level	Correct Factor	Measurement	Limit	Margin	Antenna Height	Table Degree	Comment
		MHz	dBuV	dB	dBuV/m	dBuV/m	dB	Detector	cm	degree
1	*	2455.900	107.03	-3.39	103.64	74.00	29.64	peak		
2		2483.500	58.38	-3.38	55.00	74.00	-19.00	peak		
3		2483.500	49.63	-3.38	46.25	54.00	-7.75	AVG		

Polarization: Horizontal

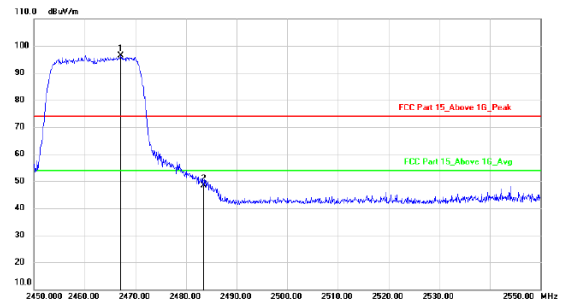

No.	Mk.	Freq.	Reading Level	Correct Factor	Measurement	Limit	Margin	Antenna Height	Table Degree	Comment
		MHz	dBuV	dB	dBuV/m	dBuV/m	dB	Detector	cm	degree
1	*	2467.100	99.71	-3.39	96.32	74.00	22.32	peak		
2		2483.500	51.68	-3.38	48.30	74.00	-25.70	peak		

Worst case : ANT1  
 Test Mode: IEEE 802.11n(HT40)-Low  
 Polarization: Vertical

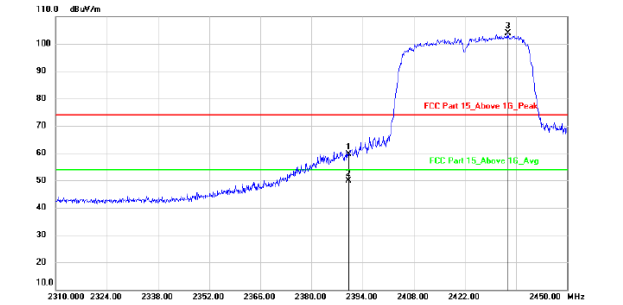

No.	Mk.	Freq.	Reading Level	Correct Factor	Measurement	Limit	Margin	Antenna Height	Table Degree	Comment
		MHz	dBuV	dB	dBuV/m	dBuV/m	dB	cm	degree	
1		2390.000	63.02	-3.40	59.62	74.00	-14.38			peak
2		2390.000	53.36	-3.40	49.96	54.00	-4.04			AVG
3	*	2433.760	107.22	-3.40	103.82	74.00	29.82			peak

Polarization: Horizontal

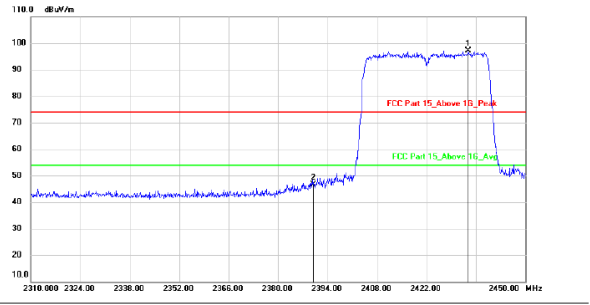

No.	Mk.	Freq.	Reading Level	Correct Factor	Measurement	Limit	Margin	Antenna Height	Table Degree	Comment
		MHz	dBuV	dB	dBuV/m	dBuV/m	dB	cm	degree	
1	*	2433.760	100.46	-3.40	97.06	74.00	23.06			peak
2		2390.000	50.04	-3.40	46.64	74.00	-27.36			peak

Test Mode: IEEE 802.11n(HT40)-High  
 Polarization: Vertical

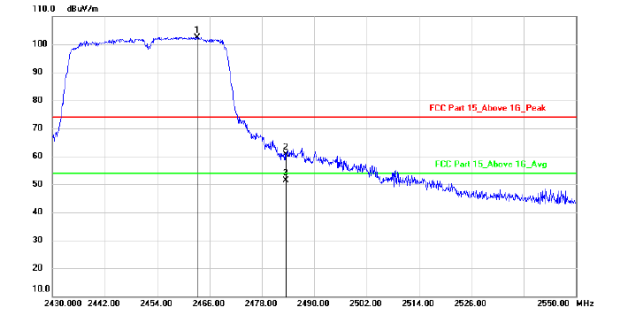

No.	Mk.	Freq.	Reading Level	Correct Factor	Measurement	Limit	Margin	Antenna Height	Table Degree	Comment
		MHz	dBuV	dB	dBuV/m	dBuV/m	dB	cm	degree	
1	*	2463.120	105.88	-3.40	102.48	74.00	28.48			peak
2		2483.500	64.03	-3.38	60.65	74.00	-13.35			peak
3		2483.500	54.74	-3.38	51.36	54.00	-2.64			AVG

Polarization: Horizontal

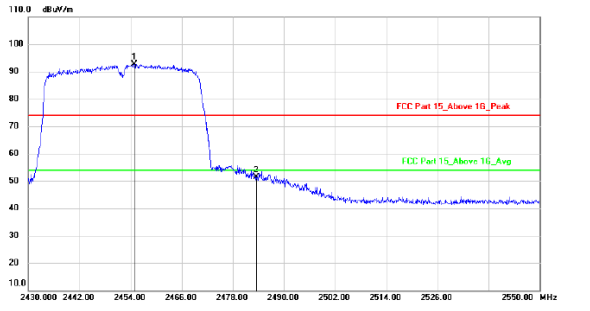

No.	Mk.	Freq.	Reading Level	Correct Factor	Measurement	Limit	Margin	Antenna Height	Table Degree	Comment
		MHz	dBuV	dB	dBuV/m	dBuV/m	dB	cm	degree	
1	*	2454.840	96.13	-3.39	92.74	74.00	18.74			peak
2		2483.500	54.80	-3.38	51.42	74.00	-22.58			peak

Note: 1. \*:Maximum data; x:Over limit; !:over margin.  
 2.Measurement=Reading Level+Correct Factor; Correct Factor=Antenna Factor+Cable Loss.

ANT1:

Test mode: 802.11b

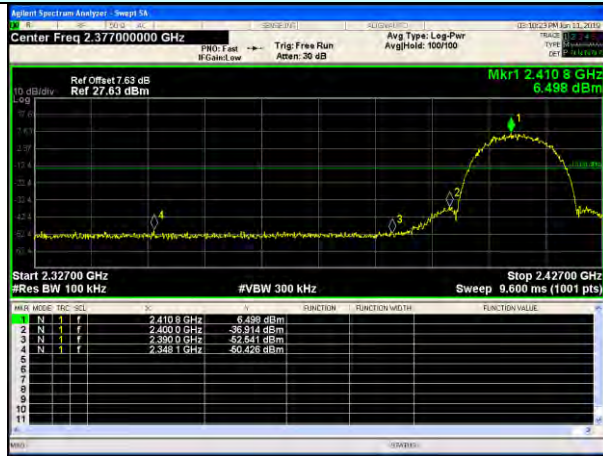

Lowest channel

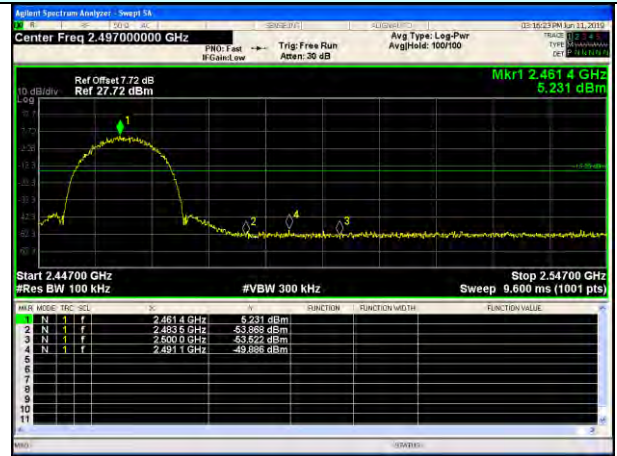

Highest channel

Test mode: 802.11g



Lowest channel

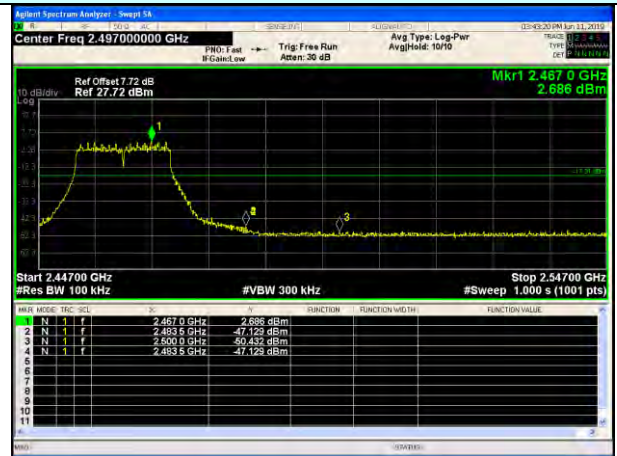

Highest channel

Test mode: 802.11n(HT20)



Lowest channel

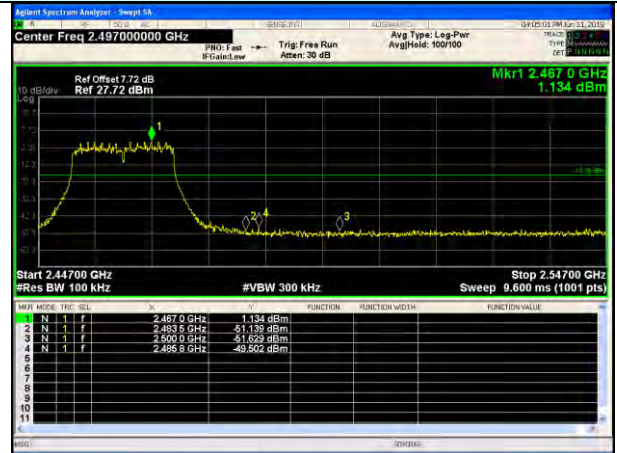

Highest channel

Test mode: 802.11n(HT40)

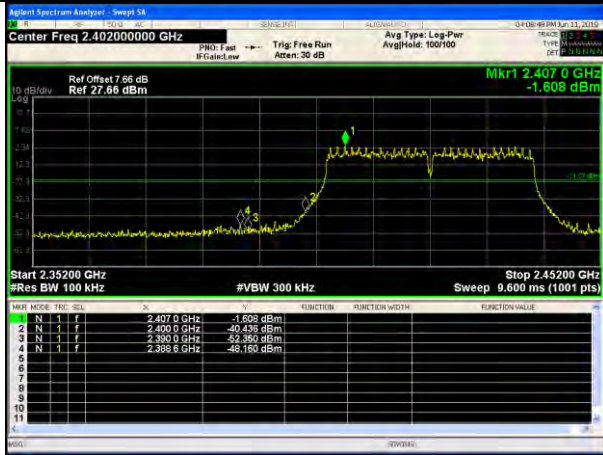

Lowest channel

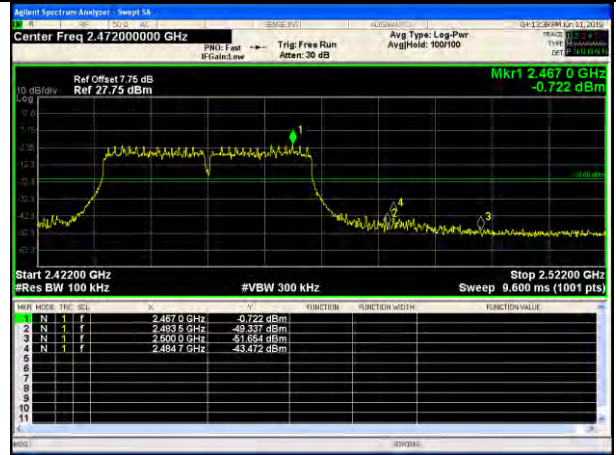

Highest channel



## **9. ANTENNA REQUIREMENT**

### **9.1. Standard Requirement**

An intentional radiator shall be designed to ensure that no antenna other than that furnished by the responsible party shall be used with the device. The use of a permanently attached antenna or of an antenna that uses a unique coupling to the intentional radiator shall be considered sufficient to comply with the provisions of this Section. The manufacturer may design the unit so that a broken antenna can be replaced by the user, but the use of a standard antenna jack or electrical connector is prohibited.

### **9.2. Antenna Connected Construction**

The antenna used for transmitting is permanently attached and no consideration of replacement. Please see EUT photo for details.

### **9.3. Results**

The product has an internal antenna. It meets the standard requirements.

Antenna connector type: ipex connector

## 10. TEST SETUP PHOTO

### 10.1. Photos of Radiated emission

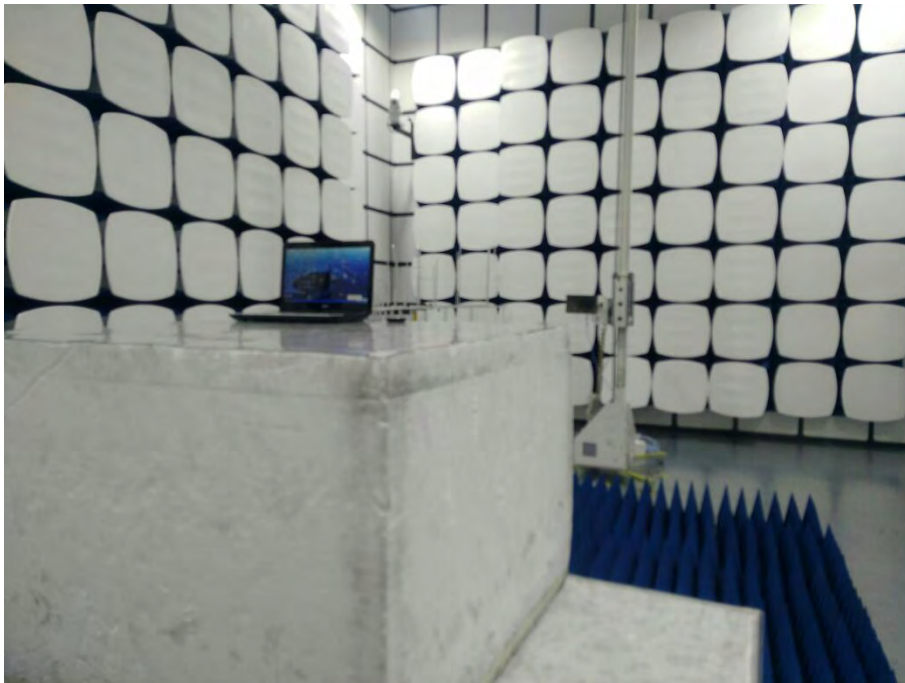
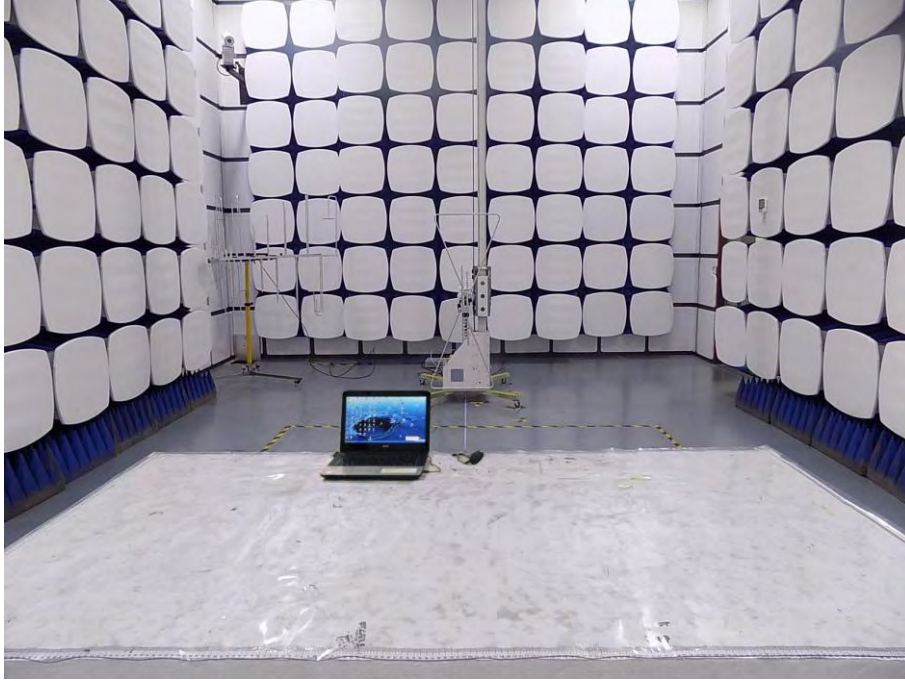

## 10.2.Photos of Conducted Emission test





### 11. TEST SETUP PHOTO

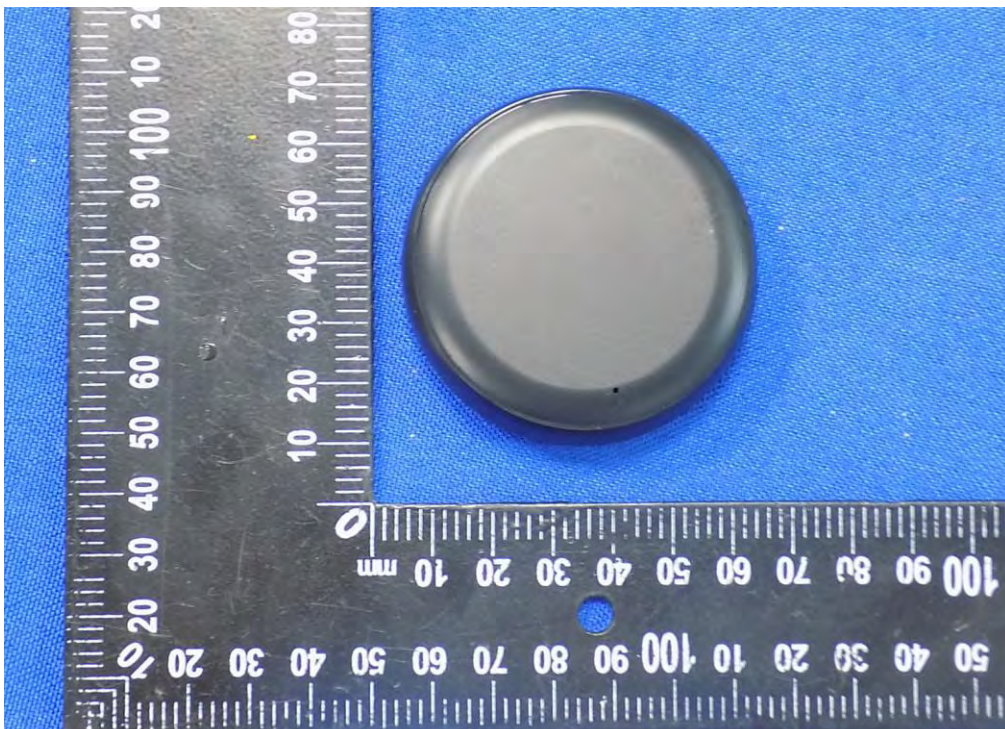









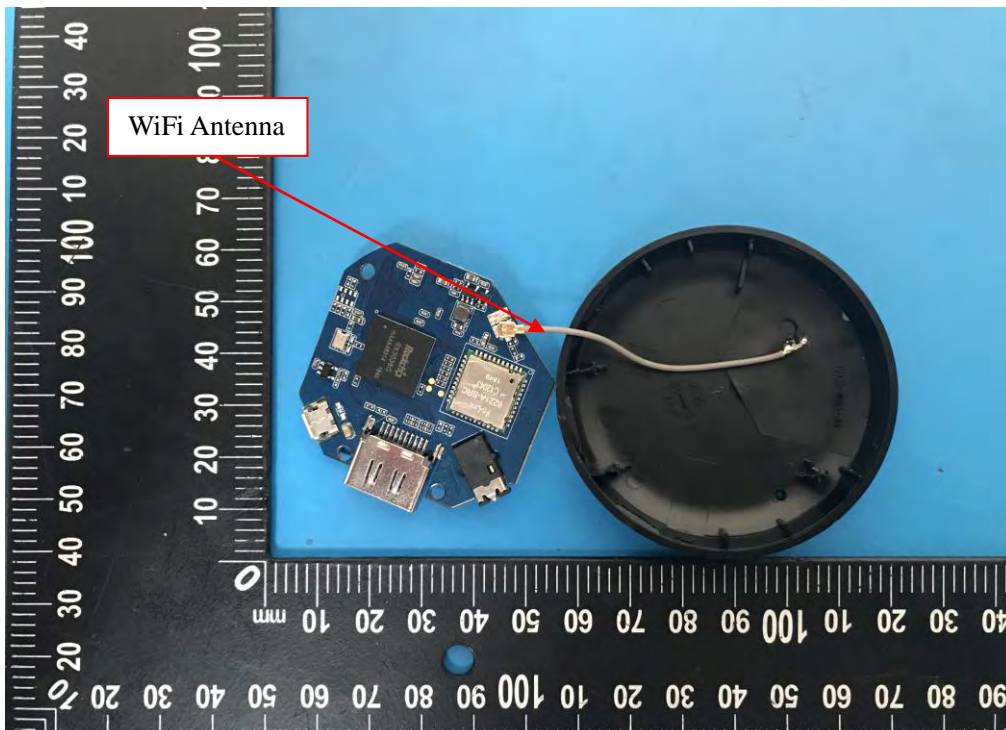
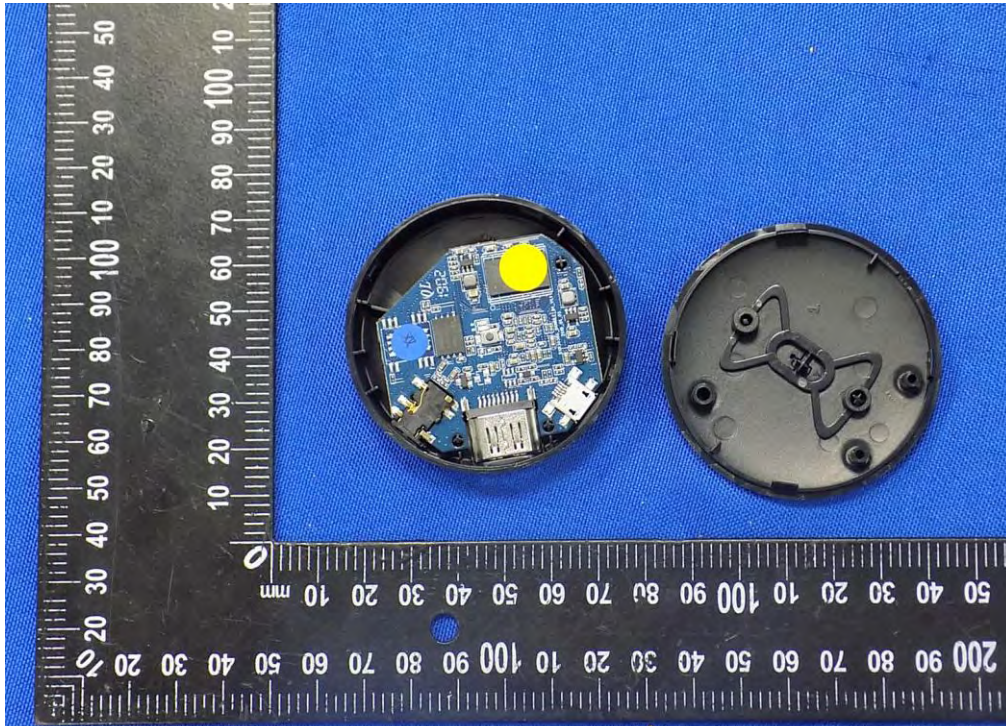



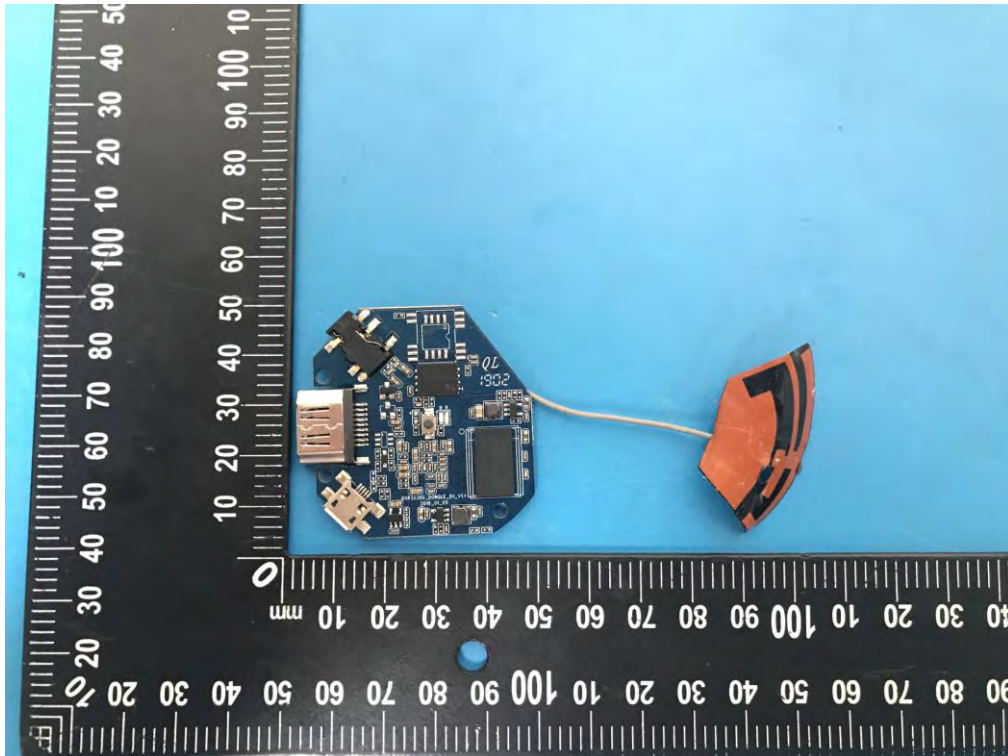
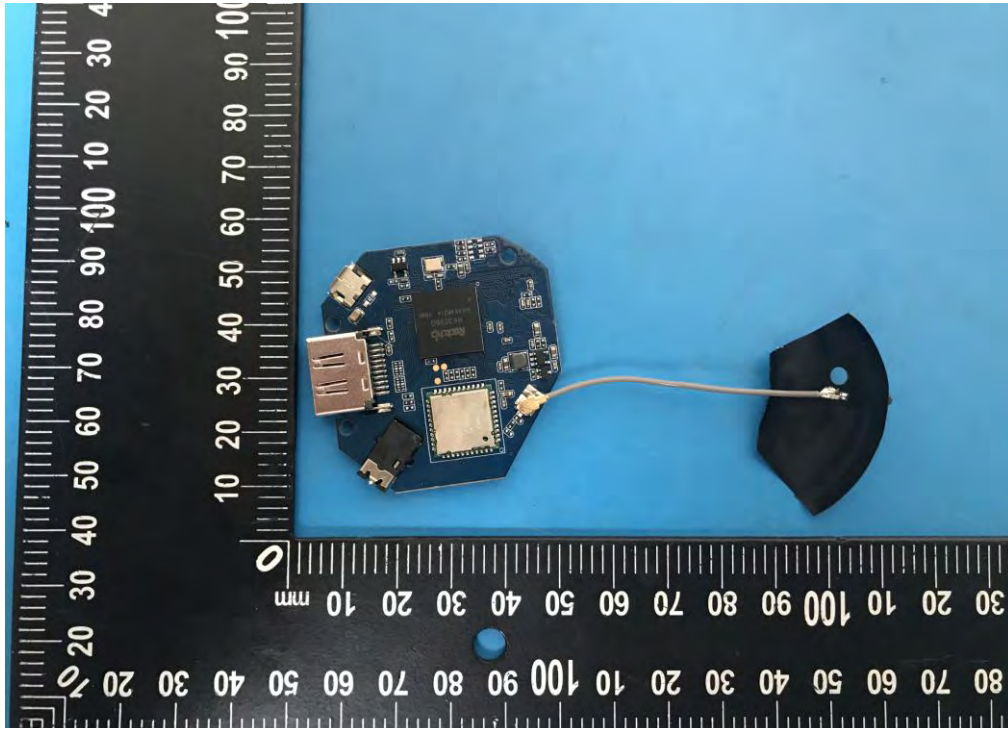



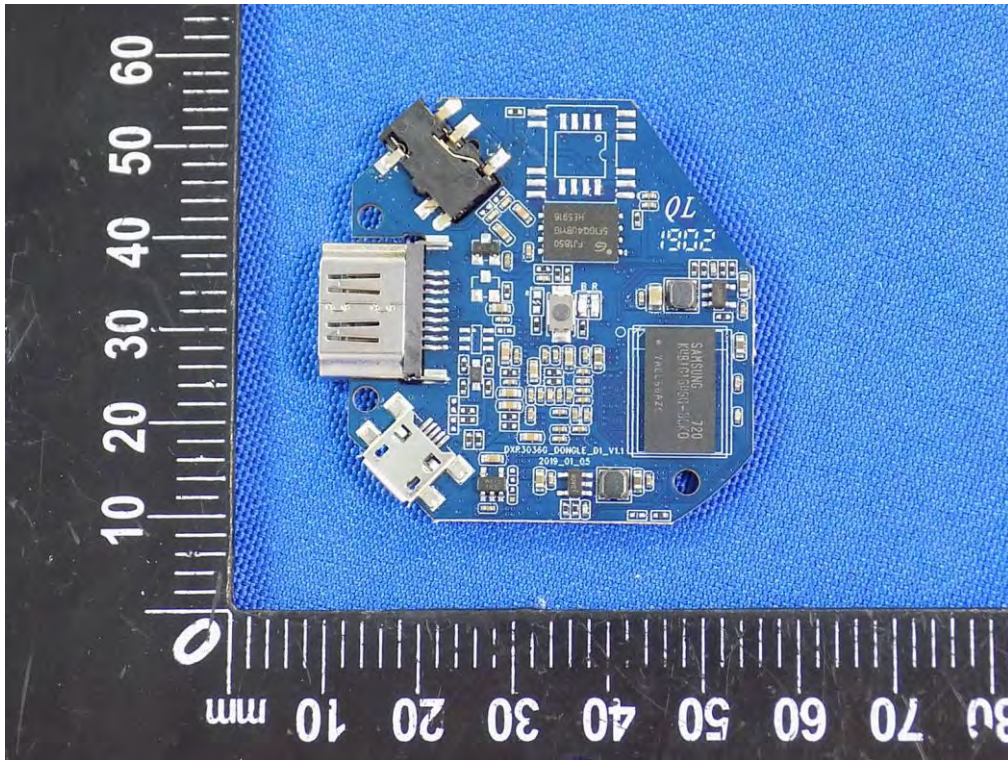
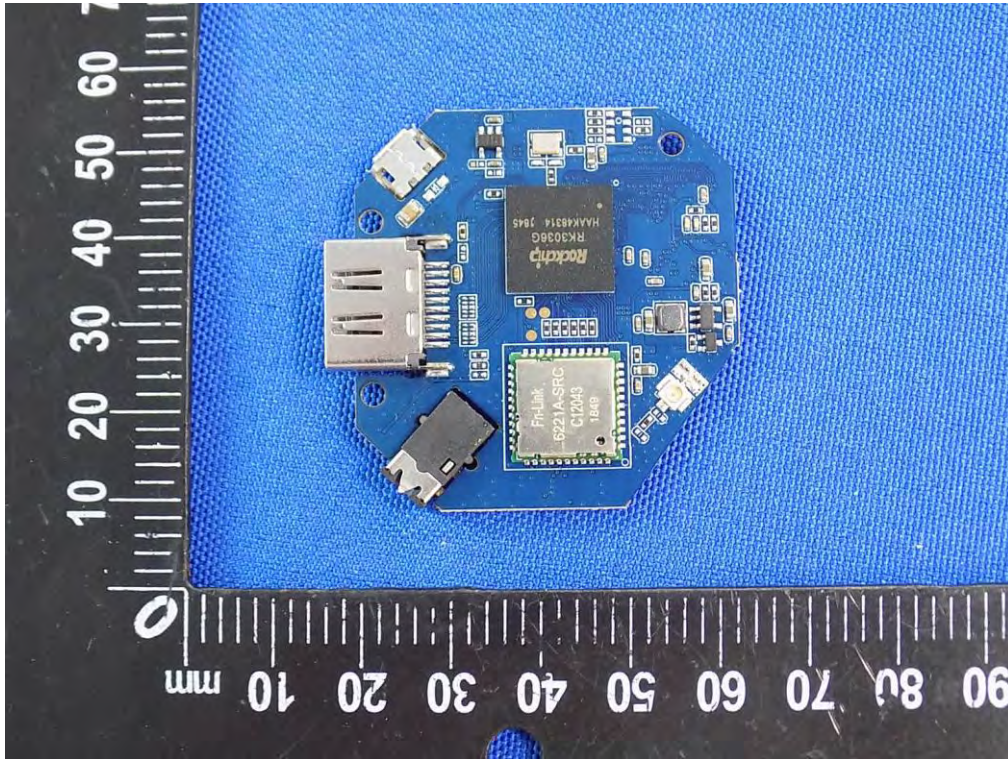

-----THE END OF REPORT-----