



FCC CO-LOCATION RADIO TEST REPORT

FCC ID : 2ARIV-2425
Equipment : Digital Media Receiver
Model Name : H23K37
Applicant : Abandon LLC
801 E. Douglas Avenue, 2nd Floor Wichita, Kansas 67202
Standard : FCC Part 15 Subpart E §15.407

The product was completed on Mar. 11, 2019. We, SPORTON INTERNATIONAL INC. EMC & Wireless Communications Laboratory, would like to declare that the tested sample has been evaluated in accordance with the test procedures and has been in compliance with the applicable technical standards.

The report must not be used by the client to claim product certification, approval, or endorsement by TAF or any agency of government.

The test results in this report apply exclusively to the tested model / sample. Without written approval of SPORTON INTERNATIONAL INC. EMC & Wireless Communications Laboratory, the test report shall not be reproduced except in full.

Approved by: Jones Tsai

SPORTON INTERNATIONAL INC. EMC & Wireless Communications Laboratory
No. 52, Huaya 1st Rd., Guishan Dist., Taoyuan City, Taiwan (R.O.C.)



Table of Contents

History of this test report..... 3

Summary of Test Result..... 4

1 General Description 5

 1.1 Product Feature of Equipment Under Test..... 5

 1.2 Modification of EUT 5

 1.3 Testing Location 5

 1.4 Applicable Standards..... 5

2 Test Configuration of Equipment Under Test 6

 2.1 Carrier Frequency and Channel 6

 2.2 Test Mode..... 6

 2.3 Connection Diagram of Test System..... 7

 2.4 Support Unit used in test configuration and system 7

 2.5 EUT Operation Test Setup 7

3 Test Result 8

 3.1 Unwanted Emissions Measurement 8

 3.2 Antenna Requirements..... 12

4 List of Measuring Equipment..... 13

5 Uncertainty of Evaluation 14

Appendix A. Radiated Spurious Emission

Appendix B. Radiated Spurious Emission Plots

Appendix C. Duty Cycle Plots



Summary of Test Result

Report Clause	Ref Std. Clause	Test Items	Result (PASS/FAIL)
3.1	15.407(b)	Unwanted Emissions	Pass
3.2	15.203 15.407(a)	Antenna Requirement	Pass

Declaration of Conformity:
The test results with all measurement uncertainty excluded are presented in accordance with the regulation limits or requirements declared by manufacturers.
Comments and Explanations:
The declared of product specification for EUT presented in the report are provided by the manufacturer, and the manufacturer takes all the responsibilities for the accuracy of product specification.

Reviewed by: Wii Chang

Report Producer: Natasha Hsieh



1 General Description

1.1 Product Feature of Equipment Under Test

Product Feature	
Equipment	Digital Media Receiver
Model Name	H23K37
FCC ID	2ARIV-2425
EUT supports Radios application	WLAN 11b/g/n HT20 WLAN 11a/n HT20/HT40 WLAN 11ac VHT20/VHT40/VHT80 Bluetooth BR/EDR/LE
Antenna Type	Fixed Internal Antenna

1.2 Modification of EUT

No modifications are made to the EUT during all test items.

1.3 Testing Location

Test Site	SPORTON INTERNATIONAL INC.
Test Site Location	No.58, Aly. 75, Ln. 564, Wenhua 3rd, Rd., Guishan Dist., Taoyuan City, Taiwan (R.O.C.) TEL: +886-3-327-0868 FAX: +886-3-327-0855
Test Site No.	Sporton Site No. 03CH11-HY

Note: The test site complies with ANSI C63.4 2014 requirement.

FCC Designation No. TW0007

1.4 Applicable Standards

According to the specifications of the manufacturer, the EUT must comply with the requirements of the following standards:

- ♦ FCC Part 15 Subpart E
- ♦ FCC KDB 789033 D02 General UNII Test Procedures New Rules v02r01.
- ♦ FCC KDB Publication No. 558074 D01 DTS Meas. Guidance v05
- ♦ FCC KDB 414788 D01 Radiated Test Site v01r01.
- ♦ ANSI C63.10-2013

Remark: All test items were verified and recorded according to the standards and without any deviation during the test.



2 Test Configuration of Equipment Under Test

The EUT has been associated with peripherals and configuration operated in a manner tended to maximize its emission characteristics in a typical application. Frequency range investigated: radiation emission (9 kHz to the 10th harmonic of the highest fundamental frequency or to 40 GHz, whichever is lower).

2.1 Carrier Frequency and Channel

2400-2483.5 MHz Bluetooth-LE 2M GFSK	
Channel	Freq. (MHz)
39	2480

2400-2483.5 MHz 802.11n HT20		5250~5350MHz 802.11n HT40	
Channel	Freq. (MHz)	Channel	Freq. (MHz)
01	2412	62	5310

2.2 Test Mode

Final test modes are considering the modulation and worse data rates as below table.

<Co-Location>

Modulation	Data Rate
Bluetooth LE for Ant. 1 + 802.11n HT20 for Ant. 0	2Mbps + MCS0
Bluetooth LE for Ant. 1 + 802.11n HT40 for Ant. 0	2Mbps + MCS0

2.3 Connection Diagram of Test System

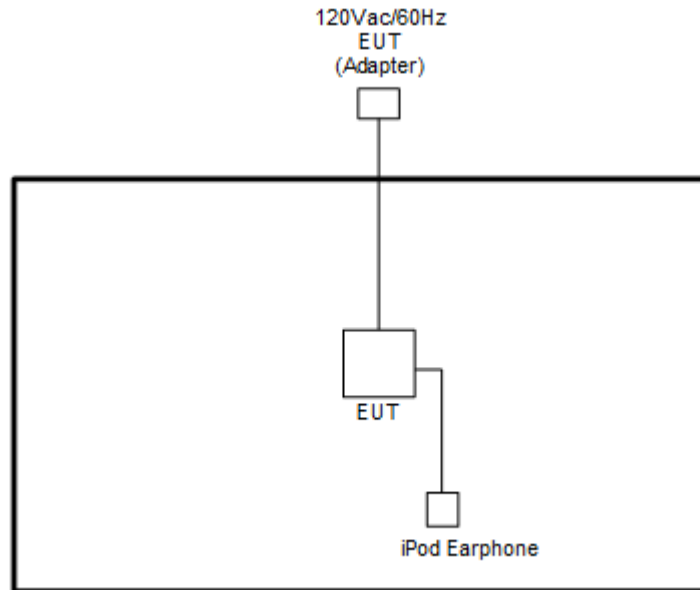

2.4 Support Unit used in test configuration and system

Item	Equipment	Trade Name	Model Name	FCC ID	Data Cable	Power Cord
1.	Ipod Earphone	AIBO	IP-E1	FCC Doc	Unshielded, 1.0 m	N/A

2.5 EUT Operation Test Setup

The RF test items, utility “compliance” was installed in Notebook which was programmed in order to make the EUT get into the engineering modes to provide channel selection, power level, data rate and the application type and for continuous transmitting signals.



3 Test Result

3.1 Unwanted Emissions Measurement

This section is to measure unwanted emissions through radiated measurement for band edge spurious emissions and out of band emissions measurement.

3.1.1 Limit of Unwanted Emissions

(1) Unwanted spurious emissions fallen in restricted bands shall comply with the general field strength limits as below table,

Frequency (MHz)	Field Strength (microvolts/meter)	Measurement Distance (meters)
0.009 – 0.490	2400/F(kHz)	300
0.490 – 1.705	24000/F(kHz)	30
1.705 – 30.0	30	30
30 – 88	100	3
88 – 216	150	3
216 - 960	200	3
Above 960	500	3

Note: The following formula is used to convert the EIRP to field strength.

$$E = \frac{1000000\sqrt{30P}}{3} \mu\text{V/m, where P is the eirp (Watts)}$$

EIRP (dBm)	Field Strength at 3m (dBμV/m)
- 27	68.3

(2) KDB789033 D02 v02r01 G)2)c)

- (i) Section 15.407(b)(1) to (b)(3) specify the unwanted emission limits for the U-NII-1 and U-NII-2 bands. As specified, emissions above 1000 MHz that are outside of the restricted bands are subject to a peak emission limit of -27 dBm/MHz.³
- (ii) Section 15.407(b)(4) specifies the unwanted emission limit for the U-NII-3 band. A band emissions mask is specified in Section 15.407(b)(4)(i). The emission limits are in terms of a Peak detector. An alternative to the band emissions mask is specified in Section 15.407(b)(4)(ii). The alternative limits are based on the highest antenna gain specified in the filing. There are also marketing and importation restrictions for the devices using the alternative limit.⁴

Note 3: An out-of-band emission that complies with both the average and peak limits of Section 15.209 is not required to satisfy the -27 dBm/MHz peak emission limit.

Note 4: Only devices with antenna gains of 10 dBi or less may be approved using the emission limits specified in Section 15.247(d) till March 2, 2018; all other devices operating in this band must use the mask specified in Section 15.407(b)(4)(i).



3.1.2 Measuring Instruments

See list of measuring equipment of this test report.

3.1.3 Test Procedures

1. The testing follows FCC KDB 789033 D02 General UNII Test Procedures New Rules v02r01. Section G) Unwanted emissions measurement.
 - (1) Procedure for Unwanted Emissions Measurements Below 1000MHz
 - RBW = 120 kHz
 - VBW = 300 kHz
 - Detector = Peak
 - Trace mode = max hold
 - (2) Procedure for Peak Unwanted Emissions Measurements Above 1000 MHz
 - RBW = 1 MHz
 - VBW \geq 3 MHz
 - Detector = Peak
 - Sweep time = auto
 - Trace mode = max hold
 - (3) Procedures for Average Unwanted Emissions Measurements Above 1000MHz
 - RBW = 1 MHz
 - VBW = 10 Hz, when duty cycle is no less than 98 percent.
 - VBW \geq 1/T, when duty cycle is less than 98 percent where T is the minimum transmission duration over which the transmitter is on and is transmitting at its maximum power control level for the tested mode of operation.
2. The EUT was placed on a turntable with 0.8 meter for frequency below 1GHz and 1.5 meter for frequency above 1GHz respectively above ground.
3. The EUT was set 3 meters from the interference receiving antenna which was mounted on the top of a variable height antenna tower.
4. The antenna is a broadband antenna and its height is adjusted between one meter and four meters above ground to find the maximum value of the field strength for both horizontal polarization and vertical polarization of the antenna.
5. For each suspected emission, the EUT was arranged to its worst case and then adjust the antenna tower (from 1 m to 4 m) and turntable (from 0 degree to 360 degrees) to find the maximum reading.

6. For testing below 1GHz, if the emission level of the EUT in peak mode was 3 dB lower than the limit specified, then peak values of EUT will be reported, otherwise, the emissions will be repeated one by one using the CISPR quasi-peak method and reported.
7. For testing above 1GHz, the emission level of the EUT in peak mode was 20dB lower than average limit (that means the emission level in average mode also complies with the limit in average mode), then peak values of EUT will be reported, otherwise, the emissions will be measured in average mode again and reported.

3.1.4 Test Setup

For radiated emissions below 30MHz

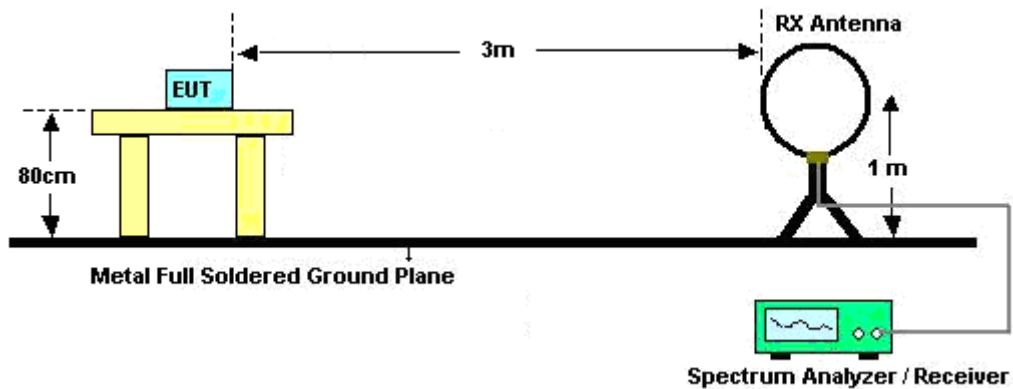

For radiated emissions from 30MHz to 1GHz

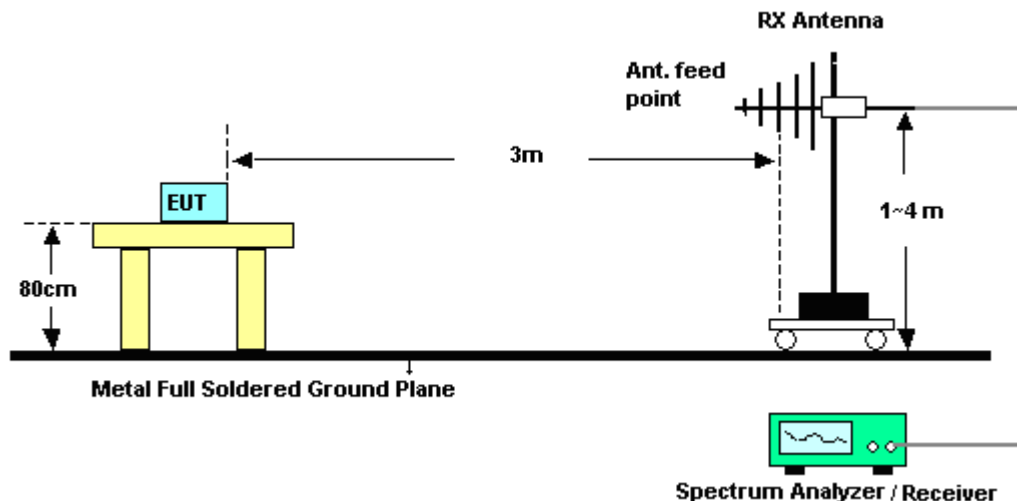

For radiated emissions above 1GHz

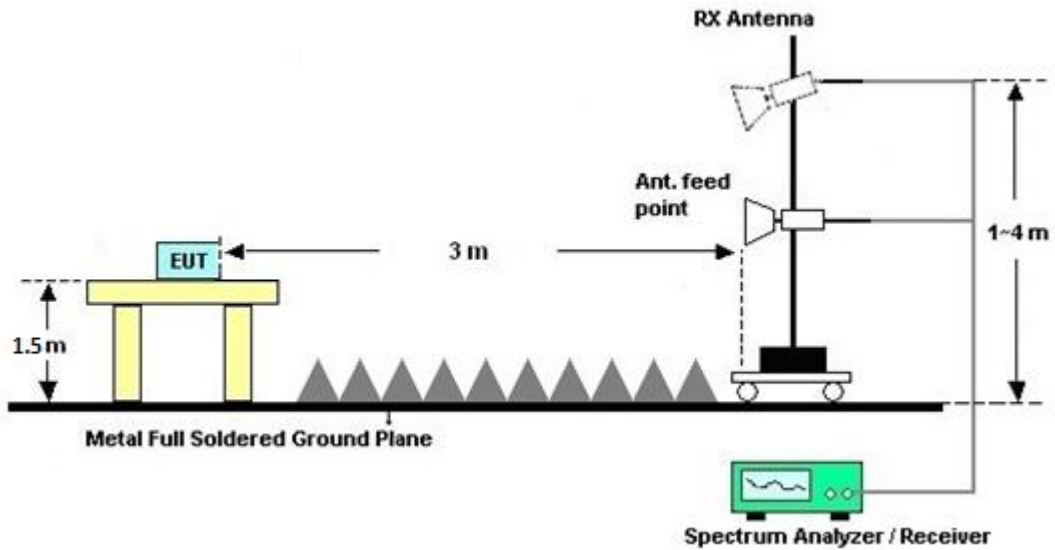

3.1.5 Test Results of Radiated Spurious Emissions (9 kHz ~ 30 MHz)

The low frequency, which started from 9 kHz to 30MHz, was pre-scanned and the result which was 20dB lower than the limit line was not reported.

There is a comparison data of both open-field test site and alternative test site - semi-Anechoic chamber according to 414788 D01 Radiated Test Site v01r01, and the result came out very similar.

3.1.6 Test Result of Radiated Spurious at Band Edges

Please refer to Appendix A and B.

3.1.7 Duty Cycle

Please refer to Appendix C.

3.1.8 Test Result of Radiated Spurious Emissions (30MHz ~ 10th Harmonic)

Please refer to Appendix A and B.



3.2 Antenna Requirements

3.2.1 Standard Applicable

If transmitting antenna directional gain is greater than 6 dBi, both the peak transmit power and the peak power spectral density shall be reduced by the amount in dB that the directional gain of the antenna exceeds 6 dBi.

3.2.2 Antenna Anti-Replacement Construction

An embedded-in antenna design is used.

3.2.3 Antenna Gain

The antenna peak gain of EUT is less than 6 dBi. Therefore, it is not necessary to reduce maximum peak output power limit.



4 List of Measuring Equipment

Instrument	Manufacturer	Model No.	Serial No.	Characteristics	Calibration Date	Test Date	Due Date	Remark
Amplifier	MITEQ	TTA1840-35-HG	1871923	18GHz~40GHz, VSWR : 2.5:1 max	Jul. 16, 2018	Mar. 07, 2019 ~ Mar. 11, 2019	Jul. 15, 2019	Radiation (03CH11-HY)
Amplifier	SONOMA	310N	187312	9kHz~1GHz	Dec. 04, 2018	Mar. 07, 2019 ~ Mar. 11, 2019	Dec. 03, 2019	Radiation (03CH11-HY)
Bilog Antenna	TESEQ	CBL 6111D &N-6-06	35414&AT-N0602	30MHz~1GHz	Oct. 13, 2018	Mar. 07, 2019 ~ Mar. 11, 2019	Oct. 12, 2019	Radiation (03CH11-HY)
Horn Antenna	SCHWARZBECK	BBHA 9120 D	9120D-1326	1GHz ~ 18GHz	Oct. 30, 2018	Mar. 07, 2019 ~ Mar. 11, 2019	Oct. 29, 2019	Radiation (03CH11-HY)
Hygrometer	TECPEL	DTN-303B	TP140325	N/A	Nov. 05, 2018	Mar. 07, 2019 ~ Mar. 11, 2019	Nov. 04, 2019	Radiation (03CH11-HY)
Loop Antenna	Rohde & Schwarz	HFH2-Z2	100488	9 kHz~30 MHz	Nov. 22, 2018	Mar. 07, 2019 ~ Mar. 11, 2019	Nov. 21, 2019	Radiation (03CH11-HY)
Preamplifier	Keysight	83017A	MY53270080	1GHz~26.5GHz	Nov. 14, 2018	Mar. 07, 2019 ~ Mar. 11, 2019	Nov. 13, 2020	Radiation (03CH11-HY)
Spectrum Analyzer	Keysight	N9010A	MY54200486	10Hz ~ 44GHz	Oct. 19, 2018	Mar. 07, 2019 ~ Mar. 11, 2019	Oct. 18, 2019	Radiation (03CH11-HY)
Controller	E MEC	EM 1000	N/A	Control Turn table & Ant Mast	N/A	Mar. 07, 2019 ~ Mar. 11, 2019	N/A	Radiation (03CH11-HY)
Antenna Mast	E MEC	AM-BS-4500-B	N/A	1~4m	N/A	Mar. 07, 2019 ~ Mar. 11, 2019	N/A	Radiation (03CH11-HY)
Turn Table	E MEC	TT 2000	N/A	0~360 Degree	N/A	Mar. 07, 2019 ~ Mar. 11, 2019	N/A	Radiation (03CH11-HY)
Preamplifier	Jet-Power	JPA0118-55-303K	1710001800054002	1GHz~18GHz	Apr. 17, 2018	Mar. 07, 2019 ~ Mar. 11, 2019	Apr. 16, 2019	Radiation (03CH11-HY)
SHF-EHF Horn Antenna	SCHWARZBECK	BBHA 9170	BBHA9170584	18GHz- 40GHz	Dec. 05, 2018	Mar. 07, 2019 ~ Mar. 11, 2019	Dec. 04, 2019	Radiation (03CH11-HY)
EMI Test Receiver	Keysight	N9038A(MXE)	MY53290045	N/A	Jan. 19, 2019	Mar. 07, 2019 ~ Mar. 11, 2019	Jan. 18, 2020	Radiation (03CH11-HY)
Software	Audix	E3 6.2009-8-24	RK-001042	N/A	N/A	Mar. 07, 2019 ~ Mar. 11, 2019	N/A	Radiation (03CH11-HY)



5 Uncertainty of Evaluation

Uncertainty of Radiated Emission Measurement (30 MHz ~ 1000 MHz)

Measuring Uncertainty for a Level of Confidence of 95% ($U = 2Uc(y)$)	5.2
---	-----

Uncertainty of Radiated Emission Measurement (1000 MHz ~ 18000 MHz)

Measuring Uncertainty for a Level of Confidence of 95% ($U = 2Uc(y)$)	5.5
---	-----

Uncertainty of Radiated Emission Measurement (18000 MHz ~ 40000 MHz)

Measuring Uncertainty for a Level of Confidence of 95% ($U = 2Uc(y)$)	5.2
---	-----



Appendix A. Radiated Spurious Emission

Test Engineer :	Hao Shu and Ken Wu	Temperature :	21~26°C
		Relative Humidity :	50~56%

Co-location Mode

2.4GHz 2400~2483.5MHz (Band Edge @ 3m)

WIFI Ant. Simultaneously	Note	Frequency (MHz)	Level (dBμV/m)	Over Limit (dB)	Limit Line (dBμV/m)	Read Level (dBμV)	Antenna Factor (dB/m)	Path Loss (dB)	Preamp Factor (dB)	Ant Pos (cm)	Table Pos (deg)	Peak Avg. (P/A)	Pol. (H/V)
BLE(2M) CH39 2480 MHz Ant 1 + 802.11n HT20 CH01 2412MHz Ant 0		2389.56	63.43	-10.57	74	53.12	27.44	16.5	33.63	100	130	P	H
		2389.92	49.04	-4.96	54	38.73	27.44	16.5	33.63	100	130	A	H
	*	2412	106.2	-	-	95.91	27.38	16.53	33.62	100	130	P	H
	*	2412	98.53	-	-	88.24	27.38	16.53	33.62	100	130	A	H
		2483.7	52.97	-21.03	74	42.68	27.3	16.59	33.6	100	130	P	H
		2483.5	43.08	-10.92	54	32.79	27.3	16.59	33.6	100	130	A	H
		2389.92	67.68	-6.32	74	57.37	27.44	16.5	33.63	123	59	P	V
		2389.92	53.5	-0.5	54	43.19	27.44	16.5	33.63	123	59	A	V
	*	2412	111.21	-	-	100.92	27.38	16.53	33.62	123	59	P	V
	*	2412	103.69	-	-	93.4	27.38	16.53	33.62	123	59	A	V
		2484.3	56.74	-17.26	74	46.45	27.3	16.59	33.6	123	59	P	V
		2483.5	45.44	-8.56	54	35.15	27.3	16.59	33.6	123	59	A	V
	Remark	1. No other spurious found. 2. All results are PASS against Peak and Average limit line.											



2.4GHz 2400~2483.5MHz and Band 2 5250~5350MHz (Band Edge @ 3m)

WIFI Ant. Simultaneously	Note	Frequency (MHz)	Level (dBμV/m)	Over Limit (dB)	Limit Line (dBμV/m)	Read Level (dBμV)	Antenna Factor (dB/m)	Path Loss (dB)	Preamp Factor (dB)	Ant Pos (cm)	Table Pos (deg)	Peak Avg. (P/A)	Pol. (H/V)
BLE(2M) CH39 2480 MHz Ant 1 + 802.11n HT40 CH62 5310MHz Ant 0		5110.16	49.69	-24.31	74	41.36	31.82	9.63	33.12	207	38	P	H
		5148.58	40.92	-13.08	54	32.46	31.9	9.68	33.12	207	38	A	H
	*	5310	104.79	-	-	96.8	31.3	9.8	33.11	207	38	P	H
	*	5310	96.49	-	-	88.5	31.3	9.8	33.11	207	38	A	H
		5350.08	59.72	-14.28	74	51.71	31.3	9.82	33.11	207	38	P	H
		5350.08	50.93	-3.07	54	42.92	31.3	9.82	33.11	207	38	A	H
		5140.76	50.44	-23.56	74	42.01	31.88	9.67	33.12	213	33	P	V
		5148.92	41.09	-12.91	54	32.63	31.9	9.68	33.12	213	33	A	V
	*	5310	105.39	-	-	97.4	31.3	9.8	33.11	213	33	P	V
	*	5310	96.79	-	-	88.8	31.3	9.8	33.11	213	33	A	V
		5350.8	63.24	-10.76	74	55.23	31.3	9.82	33.11	213	33	P	V
		5350.08	51.24	-2.76	54	43.23	31.3	9.82	33.11	213	33	A	V
Remark	1. No other spurious found. 2. All results are PASS against Peak and Average limit line.												



2.4GHz 2400~2483.5MHz (Harmonic @ 3m)

WIFI Ant. Simultaneously	Note	Frequency (MHz)	Level (dBμV/m)	Over Limit (dB)	Limit Line (dBμV/m)	Read Level (dBμV)	Antenna Factor (dB/m)	Path Loss (dB)	Preamp Factor (dB)	Ant Pos (cm)	Table Pos (deg)	Peak Avg. (P/A)	Pol. (H/V)
BLE(2M) CH39 2480 MHz Ant 1 + 802.11n HT20 CH01 2412MHz Ant 0		4824	41.27	-32.73	74	58.64	31.1	10.1	58.57	100	0	P	H
		4960	40.4	-33.6	74	57.37	31.32	10.22	58.51	100	0	P	H
		7440	42.78	-31.22	74	52.49	36.48	12.47	58.66	100	0	P	H
												P	H
		4824	40.57	-33.43	74	57.94	31.1	10.1	58.57	100	0	P	V
		4960	39.42	-34.58	74	56.39	31.32	10.22	58.51	100	0	P	V
		7440	42.88	-31.12	74	52.59	36.48	12.47	58.66	100	0	P	V
													P
Remark	1. No other spurious found. 2. All results are PASS against Peak and Average limit line.												

2.4GHz 2400~2483.5MHz and Band 2 5250~5350MHz (Harmonic @ 3m)

WIFI Ant. Simultaneously	Note	Frequency (MHz)	Level (dBμV/m)	Over Limit (dB)	Limit Line (dBμV/m)	Read Level (dBμV)	Antenna Factor (dB/m)	Path Loss (dB)	Preamp Factor (dB)	Ant Pos (cm)	Table Pos (deg)	Peak Avg. (P/A)	Pol. (H/V)
BLE(2M) CH39 2480 MHz Ant 1 + 802.11n HT40 CH62 5310MHz Ant 0		4960	50.91	-23.09	74	42.88	31.32	9.83	33.12	100	0	P	H
		4960	40.57	-13.43	54	32.54	31.32	9.83	33.12	100	0	A	H
		7440	44.11	-29.89	74	53.45	36.48	12.84	58.66	100	0	P	H
		10620	45.47	-28.53	74	51.48	39.68	15.41	61.1	100	0	P	H
		15930	43.28	-30.72	74	47.37	37.11	19.06	60.26	100	0	P	H
		4960	51.23	-22.77	74	43.2	31.32	9.83	33.12	100	0	P	V
		4960	40.84	-13.16	54	32.81	31.32	9.83	33.12	100	0	A	V
		7440	44.07	-29.93	74	53.41	36.48	12.84	58.66	100	0	P	V
		10620	44.67	-29.33	74	50.68	39.68	15.41	61.1	100	0	P	V
		15930	44.47	-29.53	74	48.56	37.11	19.06	60.26	100	0	P	V
Remark	1. No other spurious found. 2. All results are PASS against Peak and Average limit line.												



Emission below 1GHz

2.4GHz 2400~2483.5MHz (LF @ 3m)

WIFI Ant. Simultaneously	Note	Frequency (MHz)	Level (dBμV/m)	Over Limit (dB)	Limit Line (dBμV/m)	Read Level (dBμV)	Antenna Factor (dB/m)	Path Loss (dB)	Preamp Factor (dB)	Ant Pos (cm)	Table Pos (deg)	Peak Avg. (P/A)	Pol. (H/V)	
BLE(2M) CH39 2480 MHz Ant 1 + 802.11n HT20 CH01 2412MHz Ant 0		30	20.99	-19.01	40	28.61	24.01	0.75	32.38	-	-	P	H	
		178.41	22	-21.5	43.5	37.51	14.88	1.87	32.26	-	-	P	H	
		460.68	23.53	-22.47	46	29.77	23.13	2.79	32.16	-	-	P	H	
		624.61	27.59	-18.41	46	30.58	25.91	3.29	32.19	-	-	P	H	
		791.45	29.85	-16.15	46	29.9	28.11	3.74	31.9	-	-	P	H	
		928.22	32.92	-13.08	46	30.5	29.41	4.1	31.09	100	0	P	H	
														H
														H
														H
														H
														H
			40.67	31.31	-8.69	40	44.11	18.7	0.87	32.37	100	0	P	V
			81.41	27.51	-12.49	40	45.33	13.25	1.27	32.34	-	-	P	V
			161.92	27.76	-15.74	43.5	42.13	16.15	1.75	32.27	-	-	P	V
			510.15	24.8	-21.2	46	30.25	23.78	2.94	32.17	-	-	P	V
			795.33	30.57	-15.43	46	30.56	28.15	3.75	31.89	-	-	P	V
			949.56	34.39	-11.61	46	30.58	30.55	4.15	30.89	-	-	P	V
														V
														V
														V
													V	
													V	
													V	
Remark	1. No other spurious found. 2. All results are PASS against limit line.													



Emission below 1GHz

2.4GHz 2400~2483.5MHz and Band 2 5250~5350MHz (LF @ 3m)

WIFI Ant. Simultaneously	Note	Frequency (MHz)	Level (dBμV/m)	Over Limit (dB)	Limit Line (dBμV/m)	Read Level (dBμV)	Antenna Factor (dB/m)	Path Loss (dB)	Preamp Factor (dB)	Ant Pos (cm)	Table Pos (deg)	Peak Avg. (P/A)	Pol. (H/V)	
BLE(2M) CH39 2480 MHz Ant 2 + 802.11n HT40 CH62 5310MHz Ant 1		30	21.01	-18.99	40	28.63	24.01	0.75	32.38	-	-	P	H	
		65.89	18.97	-21.03	40	38.52	11.67	1.13	32.35	-	-	P	H	
		65.89	18.97	-21.03	40	38.52	11.67	1.13	32.35	-	-	P	H	
		79.47	20.04	-19.96	40	38.14	12.99	1.25	32.34	-	-	P	H	
		860.32	32.2	-13.8	46	30.5	29.31	3.95	31.56	-	-	P	H	
		957.32	33.8	-12.2	46	29.55	30.89	4.18	30.82	100	0	P	H	
														H
														H
														H
														H
														H
			40.67	31.14	-8.86	40	43.94	18.7	0.87	32.37	100	0	P	V
			81.41	26.39	-13.61	40	44.21	13.25	1.27	32.34	-	-	P	V
			159.98	28.33	-15.17	43.5	42.49	16.37	1.74	32.27	-	-	P	V
			806	30.84	-15.16	46	30.73	28.18	3.78	31.85	-	-	P	V
			903	33.23	-12.77	46	31.51	29	4.04	31.32	-	-	P	V
			958.29	34.62	-11.38	46	30.32	30.93	4.18	30.81	-	-	P	V
														V
													V	
													V	
													V	
													V	
													V	
Remark	1. No other spurious found. 2. All results are PASS against limit line.													



Note symbol

*	Fundamental Frequency which can be ignored. However, the level of any unwanted emissions shall not exceed the level of the fundamental frequency.
!	Test result is over limit line.
P/A	Peak or Average
H/V	Horizontal or Vertical



A calculation example for radiated spurious emission is shown as below:

WIFI	Note	Frequency	Level	Over	Limit	Read	Antenna	Path	Preamp	Ant	Table	Peak	Pol.
Ant.				Limit	Line	Level	Factor	Loss	Factor	Pos	Pos	Avg.	
1		(MHz)	(dBμV/m)	(dB)	(dBμV/m)	(dBμV)	(dB/m)	(dB)	(dB)	(cm)	(deg)	(P/A)	(H/V)
802.11b		2390	55.45	-18.55	74	54.51	32.22	4.58	35.86	103	308	P	H
CH 01													
2412MHz		2390	43.54	-10.46	54	42.6	32.22	4.58	35.86	103	308	A	H

1. Path Loss(dB) = Cable loss(dB) + Filter loss(dB) + Attenuator loss(dB)
2. Level(dBμV/m) =
Antenna Factor(dB/m) + Path Loss(dB) + Read Level(dBμV) - Preamp Factor(dB)
3. Over Limit(dB) = Level(dBμV/m) – Limit Line(dBμV/m)

For Peak Limit @ 2390MHz:

1. Level(dBμV/m)
= Antenna Factor(dB/m) + Path Loss(dB) + Read Level(dBμV) - Preamp Factor(dB)
= 32.22(dB/m) + 4.58(dB) + 54.51(dBμV) – 35.86 (dB)
= 55.45 (dBμV/m)
2. Over Limit(dB)
= Level(dBμV/m) – Limit Line(dBμV/m)
= 55.45(dBμV/m) – 74(dBμV/m)
= -18.55(dB)

For Average Limit @ 2390MHz:

1. Level(dBμV/m)
= Antenna Factor(dB/m) + Path Loss(dB) + Read Level(dBμV) - Preamp Factor(dB)
= 32.22(dB/m) + 4.58(dB) + 42.6(dBμV) – 35.86 (dB)
= 43.54 (dBμV/m)
2. Over Limit(dB)
= Level(dBμV/m) – Limit Line(dBμV/m)
= 43.54(dBμV/m) – 54(dBμV/m)
= -10.46(dB)

Both peak and average measured complies with the limit line, so test result is “PASS”.



Appendix B. Radiated Spurious Emission Plots

Test Engineer :	Hao Shu and Ken Wu	Temperature :	21~26°C
		Relative Humidity :	50~56%

Note symbol

-L	Low channel location
-R	High channel location

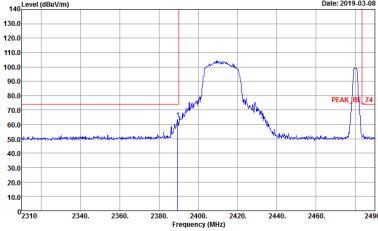
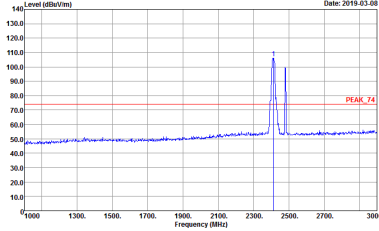
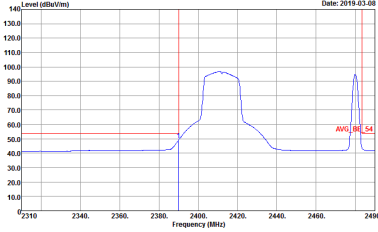
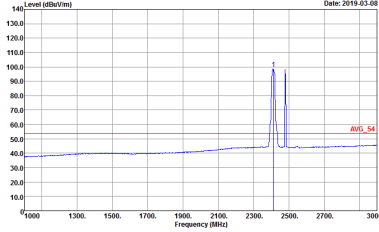

2.4GHz 2400~2483.5MHz (Band Edge @ 3m)

ANT	BLE(2M) Ch39 Ant. 1 + WIFI 802.11n HT20 Ch01 Ant. 0 - L	
Simultaneously	Horizontal	Fundamental
<p style="text-align: center;">Peak</p>	 <p style="font-size: small;">Date: 2019-03-08</p> <p style="font-size: x-small;">Site : 03CH11-HY Condition : PEAK_BE_74 3m HORN 91200-HF HORIZONTAL : RBW:1000.000KHz VBW:3000.000KHz SWT:Auto Detector : Peak Project : 892513-02 Wifi Setting : 16.5 BLE Setting : 7/0</p>	 <p style="font-size: small;">Date: 2019-03-08</p> <p style="font-size: x-small;">Site : 03CH11-HY Condition : PEAK_74 3m HORN 91200-HF HORIZONTAL : RBW:1000.000KHz VBW:3000.000KHz SWT:Auto Detector : Peak Project : 892513-02 Wifi Setting : 16.5 BLE Setting : 7/0</p>
<p style="text-align: center;">Avg.</p>	 <p style="font-size: small;">Date: 2019-03-08</p> <p style="font-size: x-small;">Site : 03CH11-HY Condition : AVG_BE_54 3m HORN 91200-HF HORIZONTAL : RBW:1000.000KHz VBW:0.010KHz SWT:Auto Detector : Peak Project : 892513-02 Wifi Setting : 16.5 BLE Setting : 7/0</p>	 <p style="font-size: small;">Date: 2019-03-08</p> <p style="font-size: x-small;">Site : 03CH11-HY Condition : AVG_54 3m HORN 91200-HF HORIZONTAL : RBW:1000.000KHz VBW:0.010KHz SWT:Auto Detector : Peak Project : 892513-02 Wifi Setting : 16.5 BLE Setting : 7/0</p>

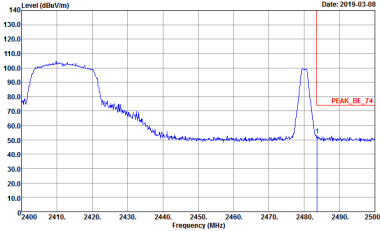
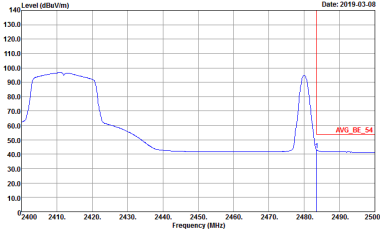

ANT	BLE(2M) Ch39 Ant. 1 + WIFI 802.11n HT20 Ch01 Ant. 0 - R	
Simultaneously	Horizontal	Fundamental
<p style="text-align: center;">Peak</p>	 <p> Site : 03CH11-HY Condition : PEAK_BE_74 3m HORN 91200-HF HORIZONTAL Detector : Peak Project : 892513-02 Wifi Setting : 16.5 BLE Setting : 7/0 </p>	<p style="text-align: center;">Left blank</p>
<p style="text-align: center;">Avg.</p>	 <p> Site : 03CH11-HY Condition : AVG_BE_54 3m HORN 91200-HF HORIZONTAL Detector : Peak Project : 892513-02 Wifi Setting : 16.5 BLE Setting : 7/0 </p>	<p style="text-align: center;">Left blank</p>

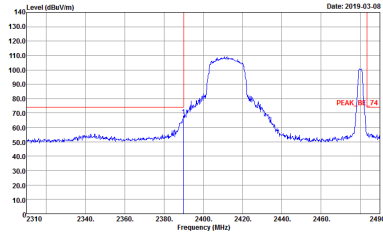
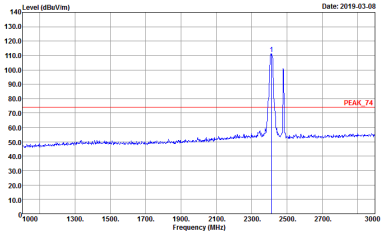
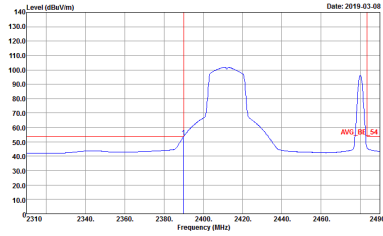
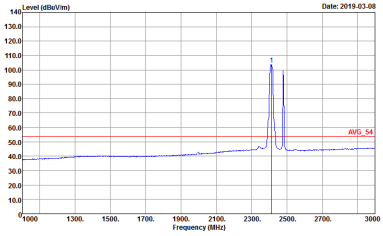

ANT	BLE(2M) Ch39 Ant. 1 + WIFI 802.11n HT20 Ch01 Ant. 0 - L	
Simultaneously	Vertical	Fundamental
<p style="text-align: center;">Peak</p>	 <p>Date: 2019-03-08</p> <p>Site : 03CH11-HY Condition : PEAK_BE_74 3m HORN 91200-HF VERTICAL : RBW:1000.000KHz VBW:3000.000KHz SWT:Auto Detector : Peak Project : 892513-02 Wifi Setting : 16.5 BLE Setting : 7/0</p>	 <p>Date: 2019-03-08</p> <p>Site : 03CH11-HY Condition : PEAK_74 3m HORN 91200-HF VERTICAL : RBW:1000.000KHz VBW:3000.000KHz SWT:Auto Detector : Peak Project : 892513-02 Wifi Setting : 16.5 BLE Setting : 7/0</p>
<p style="text-align: center;">Avg.</p>	 <p>Date: 2019-03-08</p> <p>Site : 03CH11-HY Condition : AVG_BE_54 3m HORN 91200-HF VERTICAL : RBW:1000.000KHz VBW:3000.000KHz SWT:Auto Detector : Peak Project : 892513-02 Wifi Setting : 16.5 BLE Setting : 7/0</p>	 <p>Date: 2019-03-08</p> <p>Site : 03CH11-HY Condition : AVG_54 3m HORN 91200-HF VERTICAL : RBW:1000.000KHz VBW:3000.000KHz SWT:Auto Detector : Peak Project : 892513-02 Wifi Setting : 16.5 BLE Setting : 7/0</p>

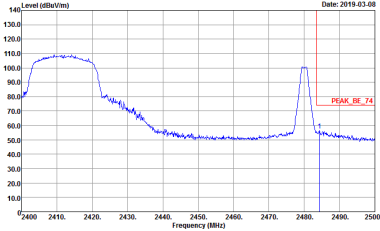
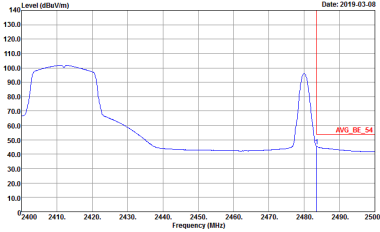

ANT	BLE(2M) Ch39 Ant. 1 + WIFI 802.11n HT20 Ch01 Ant. 0 - R	
Simultaneously	Vertical	Fundamental
<p style="text-align: center;">Peak</p>	 <p> Date: 2019.03.08 Site : 03CH11-HY Condition : PEAK_BE_74 3m HORN 91200-HF VERTICAL Detector : Peak Project : 892513-02 Wifi Setting : 16.5 BLE Setting : 7/0 </p>	<p style="text-align: center;">Left blank</p>
<p style="text-align: center;">Avg.</p>	 <p> Date: 2019.03.08 Site : 03CH11-HY Condition : AVG_BE_54 3m HORN 91200-HF VERTICAL Detector : Peak Project : 892513-02 Wifi Setting : 16.5 BLE Setting : 7/0 </p>	<p style="text-align: center;">Left blank</p>

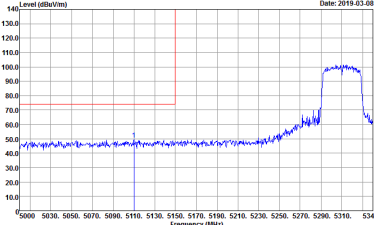
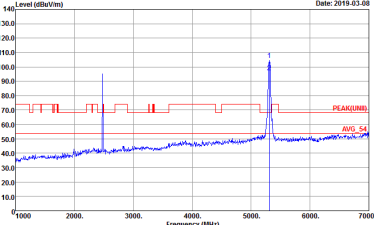
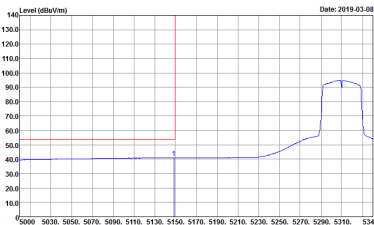

2.4GHz 2400~2483.5MHz and Band 2 5250~5350MHz (Band Edge @ 3m)

ANT	BLE(2M) Ch39 Ant. 1 + WIFI 802.11n HT40 Ch62 Ant. 0 - L	
Simultaneously	Horizontal	Fundamental
<p style="text-align: center;">Peak</p>	 <p style="font-size: small;">Date: 2019-03-08</p> <p style="font-size: x-small;">Level (dBm/1m) 140 130.0 120.0 110.0 100.0 90.0 80.0 70.0 60.0 50.0 40.0 30.0 20.0 10.0</p> <p style="font-size: x-small;">5000 5030 5050 5070 5090 5110 5130 5150 5170 5190 5210 5230 5250 5270 5290 5310 5340 Frequency (MHz)</p> <p style="font-size: x-small;">Site : 03CH11-HY Condition : PEAK_BE_74 3m HORN 9120D-HF HORIZONTAL RBW:1000.000KHz VBW:3000.000KHz SWT:Auto Detector : Peak Project : 892513-02 Mode : BLE(2M)_Tx_CH39-11a(m40)_Tx_Ch62 Wifi Setting : 16.5 BLE Setting : 7/0</p>	 <p style="font-size: small;">Date: 2019-03-08</p> <p style="font-size: x-small;">Level (dBm/1m) 140 130.0 120.0 110.0 100.0 90.0 80.0 70.0 60.0 50.0 40.0 30.0 20.0 10.0</p> <p style="font-size: x-small;">1000 2000 3000 4000 5000 6000 7000 Frequency (MHz)</p> <p style="font-size: x-small;">Site : 03CH11-HY Condition : PEAK(UNIT) 3m HORN 9120D-HF HORIZONTAL RBW:1000.000KHz VBW:3000.000KHz SWT:Auto Detector : Peak Project : 892513-02 Mode : BLE(2M)_Tx_CH39-11a(m40)_Tx_Ch62 Wifi Setting : 16.5 BLE Setting : 7/0</p>
<p style="text-align: center;">Avg.</p>	 <p style="font-size: small;">Date: 2019-03-08</p> <p style="font-size: x-small;">Level (dBm/1m) 140 130.0 120.0 110.0 100.0 90.0 80.0 70.0 60.0 50.0 40.0 30.0 20.0 10.0</p> <p style="font-size: x-small;">5000 5030 5050 5070 5090 5110 5130 5150 5170 5190 5210 5230 5250 5270 5290 5310 5340 Frequency (MHz)</p> <p style="font-size: x-small;">Site : 03CH11-HY Condition : AVG_BE_54 3m HORN 9120D-HF HORIZONTAL RBW:1000.000KHz VBW:0.010KHz SWT:Auto Detector : Peak Project : 892513-02 Mode : BLE(2M)_Tx_CH39-11a(m40)_Tx_Ch62 Wifi Setting : 16.5 BLE Setting : 7/0</p>	<p style="text-align: center;">Left blank</p>

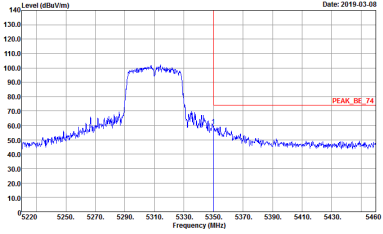
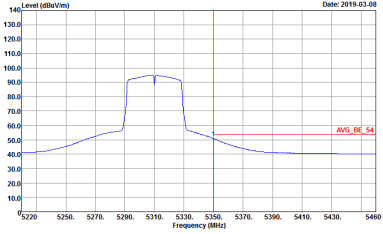

ANT	BLE(2M) Ch39 Ant. 1 + WIFI 802.11n HT40 Ch62 Ant. 0 - R	
Simultaneously	Horizontal	Fundamental
<p style="text-align: center;">Peak</p>	 <pre> Site : 03CH11-HY Condition : PEAK_BE_74 3m HORN 91200-1HF HORIZONTAL Detector : Peak Project : 892513-02 Mode : BLE(2M)_Tx_Ch39+11a(n40)_Tx_Ch62 Wifi Setting : 16.5 BLE Setting : 7/0 </pre>	<p style="text-align: center;">Left blank</p>
<p style="text-align: center;">Avg.</p>	 <pre> Site : 03CH11-HY Condition : AVG_BE_54 3m HORN 91200-1HF HORIZONTAL Detector : Peak Project : 892513-02 Mode : BLE(2M)_Tx_Ch39+11a(n40)_Tx_Ch62 Wifi Setting : 16.5 BLE Setting : 7/0 </pre>	<p style="text-align: center;">Left blank</p>

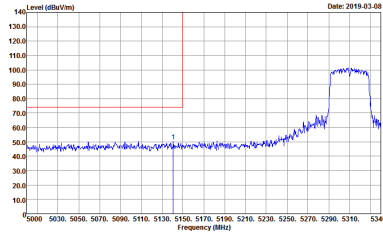
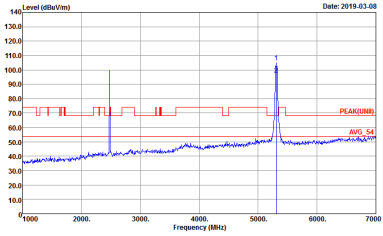
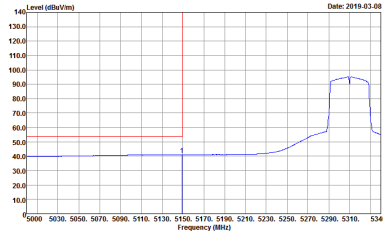

ANT	BLE(2M) Ch39 Ant. 1 + WIFI 802.11n HT40 Ch62 Ant. 0 - L	
Simultaneously	Vertical	Fundamental
<p style="text-align: center;">Peak</p>	 <p>Date: 2019-03-08</p> <p>Site : 03CH11-HY Condition : PEAK_BE_74 3m HORN 91200-HF VERTICAL Detector : Peak Project : 892513-02 Mode : BLE(2M)_Tx_Ch39+11a(n40)_Tx_Ch62 Wifi Setting : 16.5 BLE Setting : 7/0</p>	 <p>Date: 2019-03-08</p> <p>Site : 03CH11-HY Condition : PEAK(UNII) 3m HORN 91200-HF VERTICAL Detector : Peak Project : 892513-02 Mode : BLE(2M)_Tx_Ch39+11a(n40)_Tx_Ch62 Wifi Setting : 16.5 BLE Setting : 7/0</p>
<p style="text-align: center;">Avg.</p>	 <p>Date: 2019-03-08</p> <p>Site : 03CH11-HY Condition : AWG_BE_54 3m HORN 91200-HF VERTICAL Detector : Peak Project : 892513-02 Mode : BLE(2M)_Tx_Ch39+11a(n40)_Tx_Ch62 Wifi Setting : 16.5 BLE Setting : 7/0</p>	<p style="text-align: center;">Left blank</p>

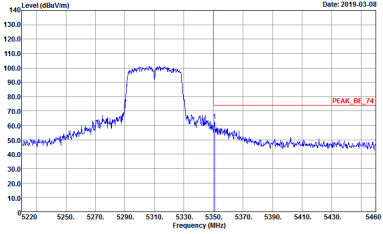
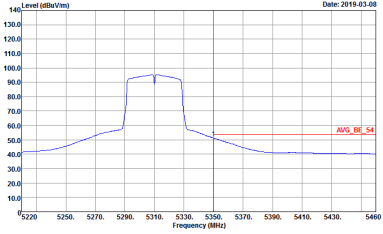

ANT	BLE(2M) Ch39 Ant. 1 + WIFI 802.11n HT40 Ch62 Ant. 0 - R	
Simultaneously	Vertical	Fundamental
<p style="text-align: center;">Peak</p>	 <p>Site : 03CH11-HY Condition : PEAK_BE_74 3m HORN 91200-1HF VERTICAL Detector : Peak Project : 892513-02 Mode : BLE(2M)_Tx_Ch39+11a(n40)_Tx_Ch62 Wifi Setting : 16.5 BLE Setting : 7/0</p>	<p style="text-align: center;">Left blank</p>
<p style="text-align: center;">Avg.</p>	 <p>Site : 03CH11-HY Condition : AVG_BE_54 3m HORN 91200-1HF VERTICAL Detector : Peak Project : 892513-02 Mode : BLE(2M)_Tx_Ch39+11a(n40)_Tx_Ch62 Wifi Setting : 16.5 BLE Setting : 7/0</p>	<p style="text-align: center;">Left blank</p>

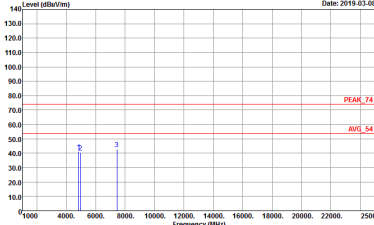
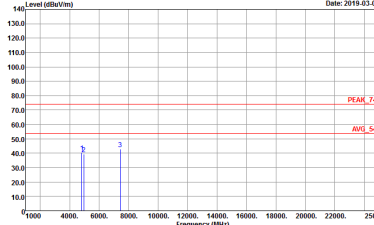

2.4GHz 2400~2483.5MHz (Harmonic @ 3m)

ANT	BLE(2M) Ch39 Ant. 1 + WIFI 802.11n HT20 Ch01 Ant. 0	
Simultaneously	Horizontal	Vertical
<p style="text-align: center;">Peak Avg.</p>	 <p>Site : 03CH11-HY Condition : PEAK_74 3m HORN 9120D-HF HORIZONTAL Detector : Peak Project : 892513-02 Wifi Setting : 16.5 BLE Setting : 770</p>	 <p>Site : 03CH11-HY Condition : PEAK_74 3m HORN 9120D-HF VERTICAL Detector : Peak Project : 892513-02 Wifi Setting : 16.5 BLE Setting : 770</p>

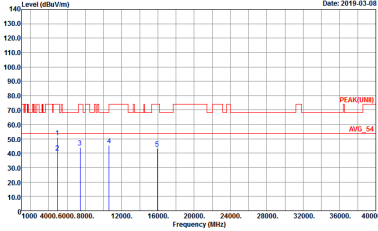

2.4GHz 2400~2483.5MHz and Band 2 5250~5350MHz (Harmonic @ 3m)

ANT	BLE(2M) Ch39 Ant. 1 + WIFI 802.11n HT40 Ch62 Ant. 0	
Simultaneously	Horizontal	Vertical
<p style="text-align: center;">Peak Avg.</p>	 <p style="font-size: small;">Date: 2019-03-08</p> <p>Site : 03CH11-HY Condition : PEAK(UNII) 3m HORN 91200-HF HORIZONTAL Detector : Peak Project : 892513-02 Mode : BLE(2M)_Tx_CH39+11n(m40)_Tx_Ch62 Wifi Setting : 16.5 BLE Setting : 7/0</p>	 <p style="font-size: small;">Date: 2019-03-08</p> <p>Site : 03CH11-HY Condition : PEAK(UNII) 3m HORN 91200-HF VERTICAL Detector : Peak Project : 892513-02 Mode : BLE(2M)_Tx_CH39+11n(m40)_Tx_Ch62 Wifi Setting : 16.5 BLE Setting : 7/0</p>

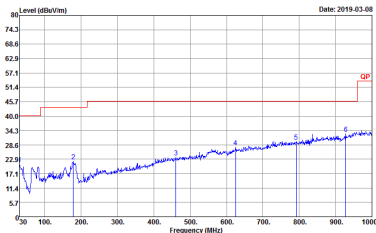
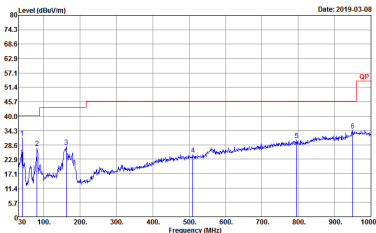

Emission below 1GHz
2.4GHz 2400~2483.5MHz (LF @ 3m)

ANT	BLE(2M) Ch39 Ant. 1 + WIFI 802.11n HT20 Ch01 Ant. 0	
Simultaneously	Horizontal	Vertical
<p>QP / Peak</p>	 <p>Site : 03CH11-HY Condition : QP 3m BT-LOG 6111D-LF_ETC HORIZONTAL Detector : Peak Project : 892513-02 WiFi Setting : 16.5 BLE Setting : 7/0</p>	 <p>Site : 03CH11-HY Condition : QP 3m BT-LOG 6111D-LF_ETC VERTICAL Detector : Peak Project : 892513-02 WiFi Setting : 16.5 BLE Setting : 7/0</p>



Emission below 1GHz

2.4GHz 2400~2483.5MHz and Band 2 5250~5350MHz (LF @ 3m)

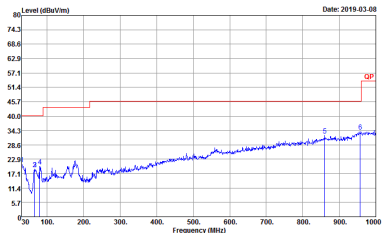
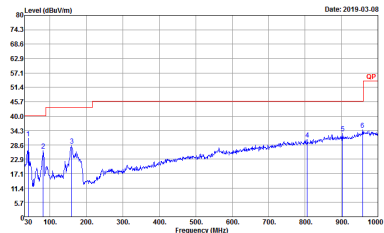
ANT	BLE(2M) Ch39 Ant. 1 + WIFI 802.11n HT40 Ch62 Ant. 0	
Simultaneously	Horizontal	Vertical
<p>QP / Peak</p>	 <p>Site : 03CH114#Y Condition : QP 3m BLE-LOG 6111D-4F_ETC HORIZONTAL Detector : Peak Project : 892513-02 Mode : BLE(2M)_Tx_Ch39-11a(n40)_Tx_Ch62 Wifi Setting : 16.5 BLE Setting : 7/0</p>	 <p>Site : 03CH114#Y Condition : QP 3m BLE-LOG 6111D-4F_ETC VERTICAL Detector : Peak Project : 892513-02 Mode : BLE(2M)_Tx_Ch39-11a(n40)_Tx_Ch62 Wifi Setting : 16.5 BLE Setting : 7/0</p>



Appendix C. Duty Cycle Plots

Antenna	Band	Duty Cycle (%)	T(us)	1/T(kHz)	VBW Setting	Duty Factor (dB)
1	Bluetooth –LE for 2Mbps	56.76	1070.00	0.93	1kHz	2.46
0	2.4GHz 802.11n HT20	100.00	-	-	10Hz	0.00
0	5GHz 802.11n HT40	100.00	-	-	10Hz	0.00

<Ant. 1>

Bluetooth – LE for 2Mbps

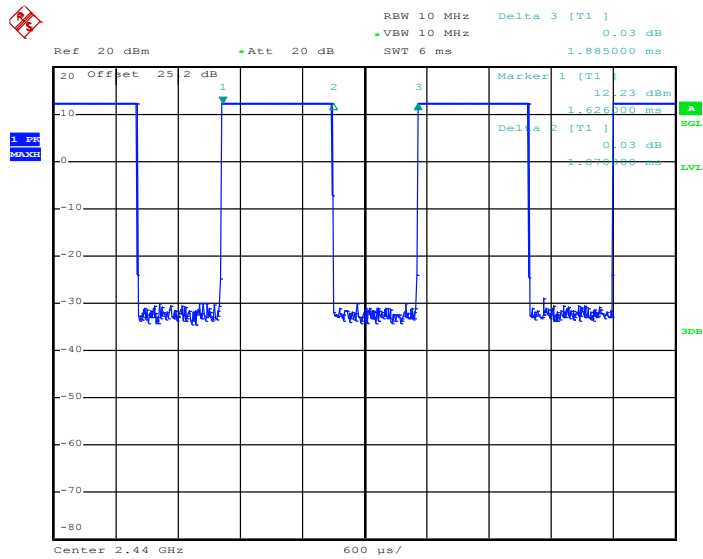

Date: 26.FEB.2019 02:54:14



<Ant. 0>

802.11n HT20

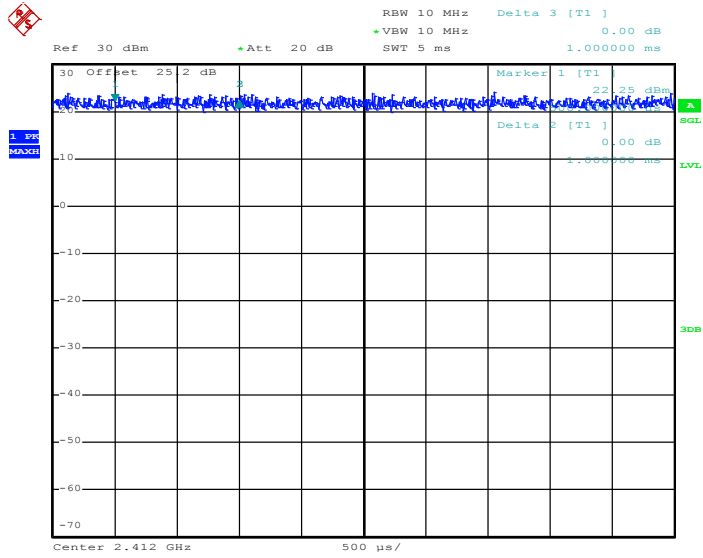

Date: 26.FEB.2019 02:33:03

802.11n HT40

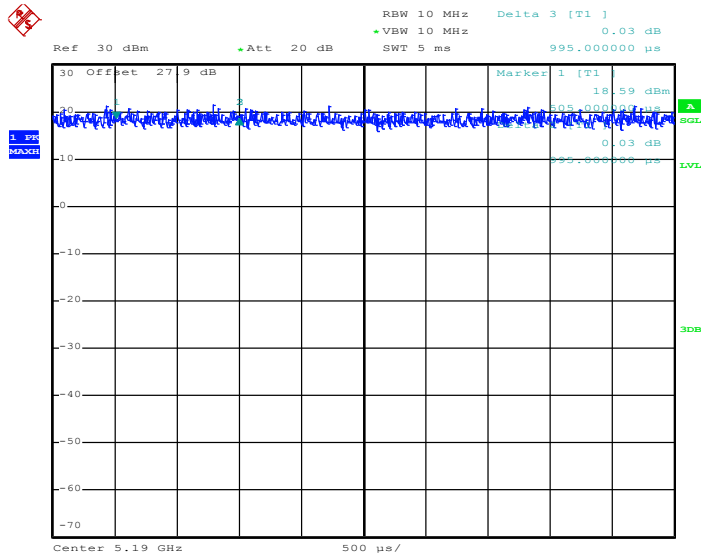

Date: 26.FEB.2019 04:31:51

—————THE END—————