

TEST REPORT

Report No.: 20050182HKG-001

PMT Holdings Limited

Application For Certification
(Original Grant)

FCC ID: 2ARIJ06139

Transmitter

Prepared and Checked by:

Approved by:

Signed On File
Lee For Yiu, Florey
Assistant Engineer

Wong Kwok Yeung, Kenneth
Senior Lead Engineer
Date: May 25, 2020

Intertek's standard Terms and Conditions can be obtained at our website <http://www.intertek.com/terms/>.

The test report only allows to be revised within the retention period unless further standard or the requirement was noticed.

This report is for the exclusive use of Intertek's Client and is provided pursuant to the agreement between Intertek and its Client. Intertek's responsibility and liability are limited to the terms and conditions of the agreement. Intertek assumes no liability to any party, other than to the Client in accordance with the agreement, for any loss, expense or damage occasioned by the use of this report. Only the Client is authorized to permit copying or distribution of this report and then only in its entirety. Any use of the Intertek name or one of its marks for the sale or advertisement of the tested material, product or service must first be approved in writing by Intertek. The observations and test results in this report are relevant only to the sample tested. This report by itself does not imply that the material, product, or service is or has ever been under an Intertek certification program.

© 2017 Intertek

TEST REPORT

GENERAL INFORMATION

Grantee:	PMT Holdings Limited
Grantee Address:	Room 511, 5/F., Peninsula Centre, 67 Mody Road, Tsim Sha Tsui East, Kowloon, Hong Kong
Contact Person:	Ricky Lam
Tel:	2328 8933
Fax:	2351 1754
e-mail:	N/A
Manufacturer:	PMT Holdings Limited
Manufacturer Address:	Room 511, 5/F., Peninsula Centre, 67 Mody Road, Tsim Sha Tsui East, Kowloon, Hong Kong
Brand Name:	PMT HOLDINGS LIMITED
Model:	06139
Type of EUT:	Transmitter
Description of EUT:	Mini RC Monster Truck
Serial Number:	N/A
FCC ID:	2ARIJ06139
Date of Sample Submitted:	May 06, 2020
Date of Test:	May 06, 2020 to May 21, 2020
Report No.:	20050182HKG-001
Report Date:	May 25, 2020
Environmental Conditions:	Temperature: +10 to 40°C Humidity: 10 to 90%
Conclusion:	Test was conducted by client submitted sample. The submitted sample as received complied with the 47 CFR Part 15 Certification.

TEST REPORT

SUMMARY OF TEST RESULT

Test Specification	Reference	Results
Transmitter Field Strength and Bandwidth Requirement	15.235	Pass

The equipment under test is found to be complying with the following standards:
FCC Part 15, October 1, 2018 Edition

TEST REPORT

TABLE OF CONTENTS

1.0 GENERAL DESCRIPTION 5

 1.1 Product Description5

 1.2 Related Submittal(s) Grants.....5

 1.3 Test Methodology5

 1.4 Test Facility5

2.0 SYSTEM TEST CONFIGURATION..... 6

 2.1 Justification.....6

 2.2 EUT Exercising Software6

 2.3 Special Accessories.....6

 2.4 Measurement Uncertainty6

 2.5 Support Equipment List and Description6

3.0 EMISSION RESULTS..... 7

 3.1 Field Strength Calculation.....7

 3.2 Radiated Emission Configuration Photograph.....8

 3.3 Radiated Emission Data.....8

4.0 EQUIPMENT PHOTOGRAPHS 10

5.0 PRODUCT LABELLING..... 10

6.0 TECHNICAL SPECIFICATIONS 10

7.0 INSTRUCTION MANUAL..... 10

8.0 MISCELLANEOUS INFORMATION 11

 8.1 Measured Bandwidth.....11

 8.2 Discussion of Pulse Desensitization12

 8.3 Calculation of Average Factor.....12

 8.4 Emissions Test Procedures12

9.0 EQUIPMENT LIST..... 15

TEST REPORT

1.0 GENERAL DESCRIPTION

1.1 Product Description

The Equipment Under Test (EUT) is portable controller for a RC car set which operates at 49.860MHz. The EUT is power by 2 x 1.5V AA batteries.

After switch on the EUT, the car will be moved forward or backward, turned left or right based on the joystick control in the controller.

Antenna Type: Internal, Integral

For electronic filing, the brief circuit description is saved with filename: descri.pdf.

1.2 Related Submittal(s) Grants

This is a single application for certification of a transmitter.

1.3 Test Methodology

Radiated emission measurements were performed according to the procedures in ANSI C63.10 (2013). All radiated measurements were performed in an 3m Chamber. Preliminary scans were performed in the 3m Chamber only to determine worst case modes. All radiated tests were performed at an antenna to EUT distance of 3 meters, unless stated otherwise in the “**Justification Section**” of this Application.

1.4 Test Facility

The 3m Chamber used to collect the radiated data is located at Workshop No. 3, G/F., World-Wide Industrial Centre, 43-47 Shan Mei Street, Fo Tan, Sha Tin, N.T., Hong Kong SAR, China. This test facility and site measurement data have been placed on file with the FCC.

TEST REPORT

2.0 SYSTEM TEST CONFIGURATION

2.1 Justification

The system was configured for testing in a typical fashion (as a customer would normally use it), and in the confines as outlined in ANSI C63.10 (2013).

The device was powered by new DC 3.0V (2 x 1.5V AA batteries).

For maximizing emissions, the EUT was rotated through 360°, the antenna height was varied from 1 meter to 4 meters above the ground plane, and the antenna polarization was changed. This step by step procedure for maximizing emissions led to the data reported in Exhibit 3.0.

The unit was operated standalone and placed in the center of the turntable.

The equipment under test (EUT) was configured for testing in a typical fashion (as a customer would normally use it). The EUT was mounted to a plastic stand if necessary and placed on the wooden turntable, which enabled the engineer to maximize emissions through its placement in the three orthogonal axes.

2.2 EUT Exercising Software

There was no special software to exercise the device. Once the unit is powered up, it transmits the RF signal continuously.

2.3 Special Accessories

There are no special accessories necessary for compliance of this product.

2.4 Measurement Uncertainty

When determining of the test conclusion, the Measurement Uncertainty of test has been considered.

2.5 Support Equipment List and Description

N/A.

TEST REPORT

3.0 EMISSION RESULTS

Data is included of the worst case configuration (the configuration which resulted in the highest emission levels). A sample calculation, configuration photographs and data tables of the emissions are included.

3.1 Field Strength Calculation

The field strength is calculated by adding the Antenna Factor and Cable Factor, and subtracting the Amplifier Gain (if any), Average Factor (optional) from the measured reading. The basic equation with a sample calculation is as follows:

$$FS = RA + AF + CF - AG - AV$$

where FS = Field Strength in dB μ V/m

RA = Receiver Amplitude (including preamplifier) in dB μ V

CF = Cable Attenuation Factor in dB

AF = Antenna Factor in dB

AG = Amplifier Gain in dB

AV = Average Factor in dB

In the following table(s), the reading shown on the data table reflects the preamplifier gain. An example for the calculations in the following table is as follows:

$$FS = RR + LF$$

where FS = Field Strength in dB μ V/m

RR = RA - AG - AV in dB μ V

LF = CF + AF in dB

Assume a receiver reading of 52.0 dB μ V is obtained. The antenna factor of 7.4 dB and cable factor of 1.6 dB are added. The amplifier gain of 29 dB and average factor of 5 dB are subtracted, giving a field strength of 27 dB μ V/m. This value in dB μ V/m was converted to its corresponding level in μ V/m.

$$RA = 52.0 \text{ dB}\mu\text{V/m}$$

$$AF = 7.4 \text{ dB}$$

$$CF = 1.6 \text{ dB}$$

$$AG = 29.0 \text{ dB}$$

$$AV = 5.0 \text{ dB}$$

$$FS = RR + LF$$

$$FS = 18 + 9 = 27 \text{ dB}\mu\text{V/m}$$

$$RR = 18.0 \text{ dB}\mu\text{V}$$

$$LF = 9.0 \text{ dB}$$

$$\text{Level in } \mu\text{V/m} = \text{Common Antilogarithm } [(27 \text{ dB}\mu\text{V/m})/20] = 22.4 \mu\text{V/m}$$

TEST REPORT

3.2 Radiated Emission Configuration Photograph

The worst case in radiated emission was found at 49.860 MHz

For electronic filing, the worst case radiated emission configuration photographs are saved with filename: radiated photos.pdf.

3.3 Radiated Emission Data

The data on the following page lists the significant emission frequencies, the limit and the margin of compliance. Numbers with a minus sign are below the limit.

Judgment: Passed by 15.1 dB

TEST REPORT

RADIATED EMISSIONS

Model: 06139

Date of Test: May 21, 2020

Worst-Case Operating Mode: Transmitting

Table 1
Pursuant to FCC Part 15 Section 15.235 Requirement

Polarization	Frequency (MHz)	Reading (dBμV)	Pre-Amp (dB)	Antenna Factor (dB)	Average Factor (dB)	Net at 3m (dBμV/m)	Limit at 3m (dBμV/m)	Margin (dB)
V	49.860	69.9	16	11.0	0.0	64.9	80.0	-15.1
V	99.720	25.1	16	12.0	-	21.1	43.5	-22.4
H	149.580	12.2	16	14.0	-	10.2	43.5	-33.3
H	199.440	8.6	16	16.0	-	8.6	43.5	-34.9
H	249.300	6.4	16	20.0	-	10.4	46.0	-35.6
H	299.160	6.5	16	22.0	-	12.5	46.0	-33.5
H	349.020	8.8	16	24.0	-	16.8	46.0	-29.2
H	398.880	5.9	16	25.0	-	14.9	46.0	-31.1
H	448.740	5.2	16	26.0	-	15.2	46.0	-30.8
H	498.600	7.1	16	26.0	-	17.1	46.0	-28.9

- NOTES:
1. Peak Detector Data unless otherwise stated.
 2. All measurements were made at 3 meters. Harmonic emissions not detected at the 3-meter distances were measured at 0.3-meter and an inverse proportional extrapolation was performed to compare the signal level to the 3-meter limit. No other harmonic emissions than those reported were detected at a test distance of 0.3-meter.
 3. Negative sign in the column shows value below limit.
 4. Horn antenna is used for the emission over 1000MHz.
 5. Emission (the row indicated by **bold italic**) within the restricted band meets the requirement of FCC Part 15 Section 15.205.
 6. Measurement Uncertainty is ±5.3dB at a level of confidence of 95%.

TEST REPORT

4.0 EQUIPMENT PHOTOGRAPHS

For electronic filing, the photographs are saved with filename: external photos.pdf and internal photos.pdf.

5.0 PRODUCT LABELLING

For electronics filing, the FCC ID label artwork and the label location are saved with filename: label.pdf.

6.0 TECHNICAL SPECIFICATIONS

For electronic filing, the block diagram and schematic of the tested EUT are saved with filename: block.pdf and circuit.pdf respectively.

7.0 INSTRUCTION MANUAL

For electronic filing, a preliminary copy of the Instruction Manual is saved with filename: manual.pdf.

This manual will be provided to the end-user with each unit sold/leased in the United States.

TEST REPORT

8.0 MISCELLANEOUS INFORMATION

The miscellaneous information includes details of the test procedure and measured bandwidth / calculation of factor such as pulse desensitization and averaging factor (calculation and timing diagram).

8.1 Measured Bandwidth

The plot shows the fundamental emission is confined in the specified band. The field strength of any emission appearing between the band edges and up to 10kHz above and below the band edges (49.81 and 49.91 MHz) is at least 42.75 dB below the carrier level. And at 49.81 & 49.91 MHz, there are at least 42.75 dB below the carrier level. It meets requirement of Section 15.235(b).

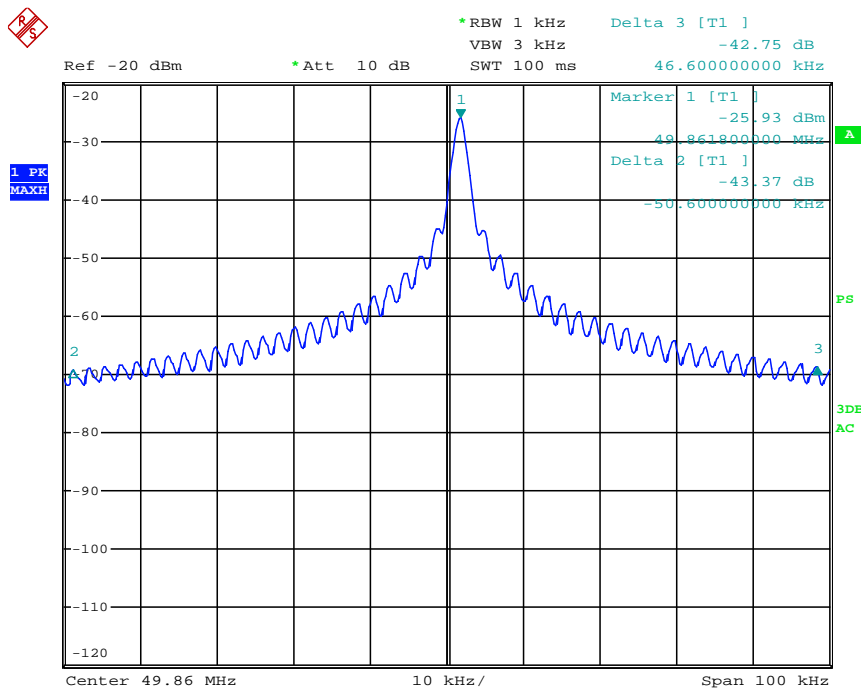

TEST REPORT

8.2 Discussion of Pulse Desensitization

Pulse desensitivity is not applicable for this device. Since the transmitter transmits the RF signal continuously.

8.3 Calculation of Average Factor

It is not necessary to apply average factor as the measured (peak) data has been complied with average limit of the radiated emission.

8.4 Emissions Test Procedures

The following is a description of the test procedure used by Intertek Testing Services Hong Kong Ltd. in the measurements of transmitter operating under the Part 15, Subpart C rules.

The transmitting equipment under test (EUT) is placed on a wooden turntable which is four feet in diameter and approximately 0.8m in height above the ground plane for emission measurement at or below 1GHz and 1.5m in height above the ground plane for emission measurement above 1GHz. During the radiated emissions test, the turntable is rotated and any cables leaving the EUT are manipulated to find the configuration resulting in maximum emissions. The EUT is adjusted through all three orthogonal axis to obtain maximum emission levels. The antenna height and polarization are also varied during the testing to search for maximum signal levels. The height of the antenna is varied from one to four meters.

Detector function for radiated emissions is in peak mode. Average readings, when required, are taken by measuring the duty cycle of the equipment under test and subtracting the corresponding amount in dB from the measured peak readings. A detailed description for the calculation of the average factor can be found in Exhibit 8.3.

The frequency range scanned is from the lowest radio frequency signal generated in the device which is greater than 9 kHz to the tenth harmonic of the highest fundamental frequency or 40 GHz, whichever is lower.

TEST REPORT

8.4 Emissions Test Procedures (cont'd)

The EUT is warmed up for 15 minutes prior to the test.

AC power to the unit is varied from 85% to 115% nominal and variation in the fundamental emission field strength is recorded. If battery powered, a new, fully charged battery is used.

Conducted measurements were made as described in ANSI C63.10 (2013).

The IF bandwidth used for measurement of radiated signal strength was 100 kHz or greater when frequency is below 1000 MHz. Where pulsed transmissions of short enough pulse duration warrant, a greater bandwidth is selected according to the recommendations of Hewlett Packard Application Note 150-2. A discussion of whether pulse desensitivity is applicable to this unit is included in this report (See Exhibit 8.1). Above 1000 MHz, a resolution bandwidth of 3 MHz is used.

Transmitter measurements are normally conducted at a measurement distance of three meters. However, to assure low enough noise floor in the forbidden bands and above 1 GHz, signals are acquired at a distance of one meter or less. All measurements are extrapolated to three meters using inverse scaling, unless otherwise reported. Measurements taken at a closer distance are so marked.

TEST REPORT

8.4.1 Radiated Emission Test Setup

The figure below shows the test setup, which is utilized to make these measurements.

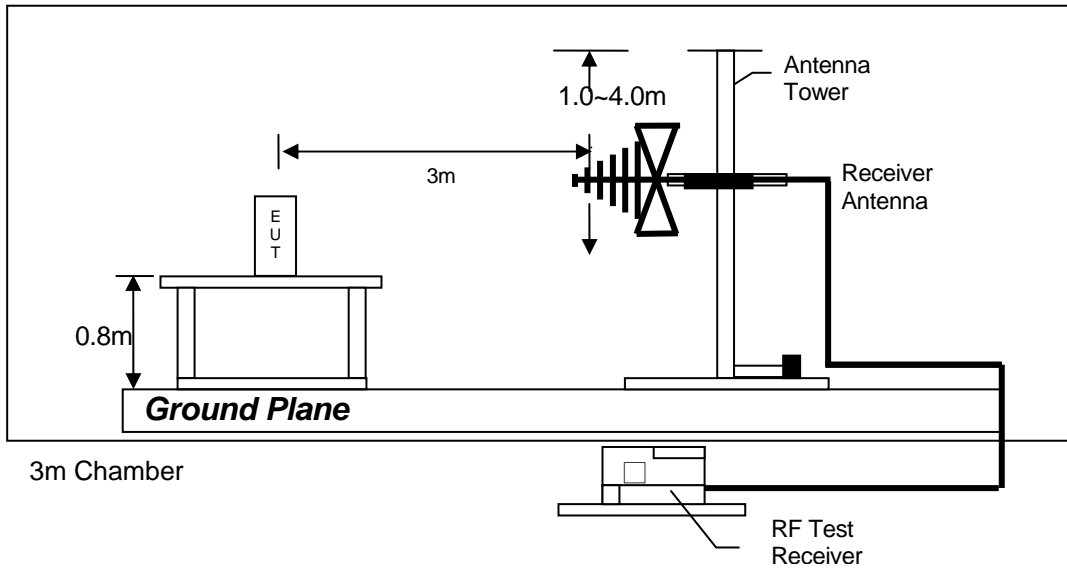

Test setup of radiated emissions up to 1GHz

TEST REPORT

9.0 EQUIPMENT LIST

1) Radiated Emissions Test

Equipment	EMI Test Receiver	Spectrum Analyzer	Biconical Antenna
Registration No.	EW-2251	EW-3156	EW-0571
Manufacturer	ROHDESCHWARZ	ROHDESCHWARZ	EMCO
Model No.	ESCI7	ESR26	3104C
Calibration Date	June 21, 2019	August 01, 2019	July 23, 2019
Calibration Due Date	June 21, 2020	August 01, 2020	January 23, 2021

Equipment	Log Periodic Antenna	14m Double Shield RF Cable (20MHz - 6GHz)
Registration No.	EW-1042	EW-2505
Manufacturer	EMCO	RADIALL
Model No.	3148	Nm-RG142-
Calibration Date	November 23, 2018	November 14, 2019
Calibration Due Date	November 23, 2020	November 14, 2020

Equipment	RF Pre-amplifier 3 pcs (9kHz to 40GHz)	Horn Antenna (14GHz - 40GHz)
Registration No.	EW-3006	EW-0905
Manufacturer	SCHWARZBECK	SCHWARZBECK
Model No.	BBV 9718	BBHA9170
Calibration Date	November 25, 2019	January 23, 2019
Calibration Due Date	November 25, 2020	January 23, 2021

2) Bandwidth Measurement

Equipment	Spectrum Analyzer
Registration No.	EW-2253
Manufacturer	ROHDESCHWARZ
Model No.	FSP40
Calibration Date	November 18, 2019
Calibration Due Date	November 18, 2020

END OF TEST REPORT