

Front

Barbecue that's twice as nice!
-Mr. Bar-B-Q



**WIRELESS BARBECUE
DUAL THERMOMETER**

Multifunction Temperature and Taste Ranges
Two Steel Probes
Remote Range of 100 Ft. (30.48 Meters)
Transmitter Cradle and Receiver Unit

**WIRELESS BARBECUE
DUAL THERMOMETER**

Multifunction Temperature and Taste Ranges
Two Steel Probes
Remote Range of 100 Ft. (30.48 Meters)
Transmitter Cradle and Receiver Unit

**PRODUCT
POSITION**

TWO STEEL PROBES MONITOR TEMPERATURE OF TWO MEATS AT THE SAME TIME
TWO STEEL PROBES MONITOR TEMPERATURE OF TWO MEATS AT THE SAME TIME

Back

Barbecue that's twice as nice!
-Mr. Bar-B-Q



**WIRELESS BARBECUE
DUAL THERMOMETER**

Multifunction Temperature and Taste Ranges Two Steel Probes
Remote Range of 100 Ft. (30.48 Meters) • Transmitter Cradle and Receiver Unit

WIRELESS BARBECUE DUAL THERMOMETER

Multifunction Temperature and Taste Ranges Two Steel Probes
Remote Range of 100 Ft. (30.48 Meters) • Transmitter Cradle and Receiver Unit

WARNING

Do not mix alkaline batteries, standard (carbon-zinc) batteries or rechargeable (nickel-cadmium) batteries. Do not put batteries in a fire. Do not install batteries backwards. Do not mix old and new batteries. Batteries may explode or leak causing injury. Remove batteries if unit is stored for extensive periods of time. Remove batteries if consumed. Replace all batteries at the same time. Keep batteries away from children. If swallowed, promptly see doctor.

ADVERTENCIA

No mezclar pilas alcalinas, pilas estándar (carbono-zinc) o pilas recargables (níquel-cadmio). No exponer las pilas al fuego. No colocar las pilas en posición invertida. No mezclar pilas nuevas con pilas usadas. Las pilas pueden explotar o tener fugas causando daños. Retire las baterías si la unidad permanecerá almacenada durante largos periodos de tiempo. Retire la batería si está agotada. Reemplazar todas las pilas al mismo tiempo. Mantener las pilas fuera del alcance de los niños. En caso de ingestión, consultar con un médico inmediatamente.

PATENT PENDING
40128Y



Made in China / Hecho en China
Distributed by / Distribuido por
© Blue Rhino Global Sourcing, Inc.
10 Hub Dr., Ste 101, Melville, NY 11747
1.888.398.8643 • MrBarBQ.com

**BATTERIES
POSITION**



Mr. Bar-B-Q is a registered trademark of Blue Rhino Global Sourcing, Inc.
Mr. Bar-B-Q es una marca comercial registrada de Blue Rhino Global Sourcing, Inc.

**PRODUCT
POSITION**

5 "AAA" Batteries Included
Instruction Sheet Included Inside Packaging

Se incluyen 5 baterías "AAA"
Hoja de instrucciones incluida en el paquete

INTRODUCTION

This wireless food thermometer has dual probes that can independently display the temperature, meat type and cooked level of meat. The LCD back light color can be changed according to the temperatures and an alarm is issued when it reaches a set temperature.

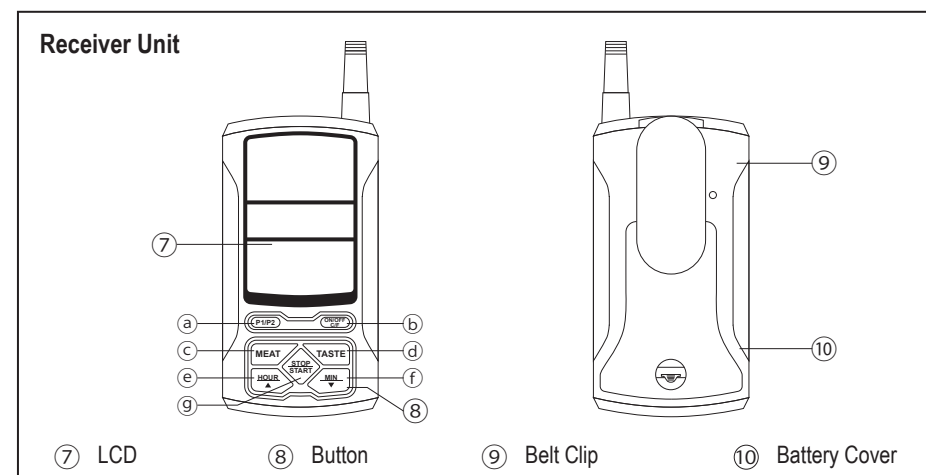
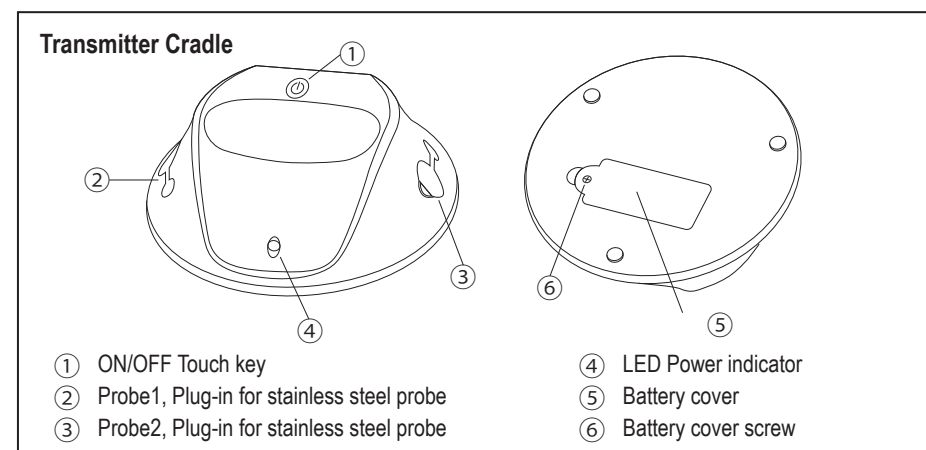

Receiver Unit Profiles:

- Ⓐ **P1/P2** : Press to select Probe(1) Meat Type / Probe(2) Meat Type.
- Ⓑ **ON/OFF C/F** : Switch on back above clip - turns receiver on and off. In THERMOMETER mode, press to select temperature readings in Celsius or Fahrenheit.
- Ⓒ **MEAT** : In THERMOMETER mode press to select meat type (beef, veal, lamb, pork, chicken, turkey).
- Ⓓ **TASTE** : In THERMOMETER mode press to select taste-doneness level (W.DONE, MEDIUM, M.RARE or RARE).
- Ⓔ **HOUR** : In TIMER MODE, press to set hour, in THERMOMETER MODE, press to increase the temperature value.
- Ⓕ **MIN** : In timer mode, press to set minutes. In THERMOMETER mode, press to decrease temperature value.
- Ⓖ **START / STOP** : Press to start or stop the timer count down or count up.

The Receiving Distance: 100 feet

Temperature Measurement Range: -10°C~300°C (14°F~572°F), "LLL" will be displayed below 14°F and "HHH" will be displayed above 572°F

INSTALLING BATTERIES

Transmitter Cradle

- The transmitter unit use 2 AAA batteries.
- Use a screwdriver to remove the screw ⑥ on bottom, remove the cover ⑤ and insert the batteries and align the battery with + and - mark.
- Close the battery cover and tighten the screws.

Receiver Unit

- The receiver unit use 3 AAA batteries.
- Remove the below clip ⑨ to access battery compartment.
- Remove the cover ⑩ and insert the batteries and align the battery with + and - mark.
- Close the battery cover.

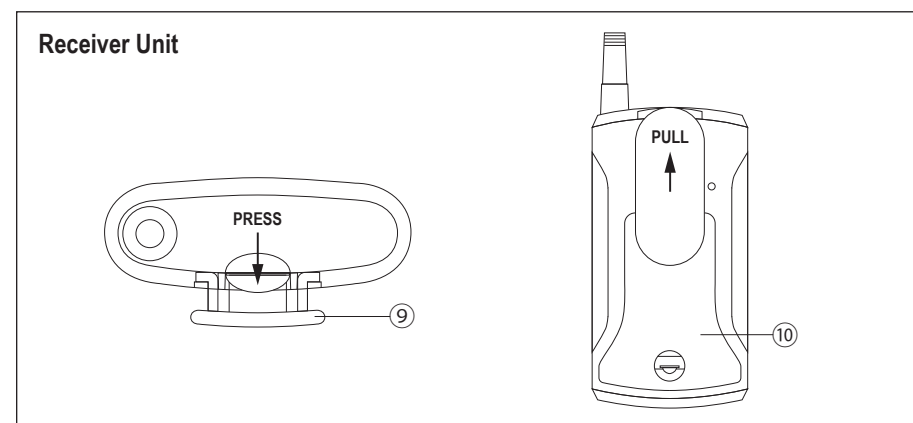

WARNING

Do not mix old and new batteries. Do not mix alkaline, standard (Carbon-Zinc) or rechargeable (Nickel-Cadmium) batteries. Remove batteries when storing product for extended periods of time. Avoid contact with water as moisture can damage receiver unit, transmitter unit is waterproof (IPX6). Do not put batteries in a fire. Do not install batteries backwards. Do not mix old and new batteries. Batteries may explode or leak causing injury. Remove batteries if unit is stored for extensive periods of time. Remove batteries if consumed. Replace all batteries at the same time. Keep batteries away from children. If swallowed, promptly see doctor.

COOKING OPERATION

- Plug the probe connector to the transmitter unit jack.
- Press the transmitter unit **ON/OFF** touch key ①, the red LED ④ is on.
- Press the receiver unit **ON/OFF** button to turn on the receiver, LCD displays temperature; turn the unit off press and hold the **ON/OFF** button for 3 seconds. If no buttons are pressed after 1 hour, the unit will automatically turn off. If timer is countdown, the timer is STOPPED for over an hour should the auto shut off activate.
- Press the **P1/P2** button to select probe1, the symbol "Probe(1) Meat Type" will blinking, press again the **P1/P2** button to select probe2, the symbol "Probe(2) Meat Type" will blinking. If no buttons are pressed after 10 seconds, the data is automatically saved.
- In symbol blinking, press the **MEAT** button to select the type of meat that you are cooking.
- Each press of the **MEAT** button will cycle through the selections:
BEEF → VEAL → LAMB → PORK → FISH → POULTRY (PLTRY) → GROUND POULTRY (G-PTY) → HAMBURGER (HMBGR) → OTHER → -----
- Press the **TASTE** button to select the doneness of meat that you desire.
- East press of the **TASTE** button to will cycle through the selections:
WELL DONE → MEDIUM WELL → MEDIUM → MEDIUM RARE → RARE

NOTE:

If you select meat type "OTHER" you can set the desired internal temperature manually. The default temperature is 135°F. Press the "▲" or "▼" buttons to set the desired target temperature. Press and hold the button to fast increase or decrease the value. Press the **TASTE** button to accept the final target temperature. The selectable range is 110°F to 180°F. If you select meat type "----", no target temperature display.

- Press **C / F** button to select the preferred temperature units.
- The color-changing LCD shows your entree's progress.

Green:	RARE	≤ Current temperature <	MEDIUM RARE
Baby Blue:	MEDIUM RARE	≤ Current temperature <	MEDIUM
Purple:	MEDIUM	≤ Current temperature <	MEDIUM WELL
Orange:	MEDIUM WELL	≤ Current temperature <	WELL DONE
Red:	WELL DONE	≤ Current temperature	

- Once the meat probe has reached the desired internal temperature, a loud beeping alarm will sound and the LCD backlight will blinking, the symbol "Probe(1) Meat Type" or "Probe(2) Meat Type" will blinking, the icon and current temperature value will flash also. The audible signal will be four beeps with one second of silence between beeps.
- Press "STOP" to silence the alarm signal. Note that the symbol "Probe(1) Meat Type" or "Probe(2) Meat Type", the icon symbol and LCD backlight will continue to flash unless current temperature is below target temperature.

TASTE / MEAT	BEEF	VEAL	LAMB	PORK	FISH	POULTRY	GROUND POULTRY	HAMBURGER	OTHER
Well Done	77°C 170.6°F	77°C 170.6°F	77°C 170.6°F	77°C 170.6°F	63°C 145.4°F	74°C 165.2°F	74°C 165.2°F	/	57°C 134.6°F
Medium well done	74°C 165.2°F	74°C 165.2°F	74°C 165.2°F	74°C 165.2°F	/	/	/	/	
Medium	71°C 159.8°F	71°C 159.8°F	71°C 159.8°F	71°C 159.8°F	/	/	/	71°C 159.8°F	
Medium rare	63°C 145.4°F	63°C 145.4°F	63°C 145.4°F	/	/	/	/	/	
Rare	57°C 134.6°F	57°C 134.6°F	57°C 134.6°F	/	/	/	/	/	/
USDA recommended temperatures	62.8°C 145°F	62.8°C 145°F	62.8°C 145°F	62.8°C 145°F	62.8°C 145°F	73.9°C 165°F	73.9°C 165°F	71.1°C 160°F	/

TIME OPERATION

- The count-up and countdown timers operate independently of the temperature probe sensors.
- If no countdown time is set the timer will act as a count up timer, press **START / STOP** button to begin count-up, the icon "▲" will flash, the timer will count up to 23 hours 59 minutes.
- Press the **HOUR** or **MIN** button to select the desired cooking time.
- If you hold the button for more then 10 seconds, the digits will increase/decrease rapidly.
- To reset the time, press the **HOUR** and **MIN** button together.
- Press **START / STOP** button to begin countdown, the icon "▼" will flash.
- Press **START / STOP** again to pause. Once pause, press **HOUR** and **MIN** button together to reset to zero.
- Once a countdown has finished, the **TIMER** LCD backlight will blinking, the unit will beep, 2 times repeatedly until you press the **STOP** button. The alert will silence itself after 30 seconds.

LCD BACKLIGHT

- Press any button to illuminate the screen for 10 seconds.

AFTER COOKING

- Once cooking is finished, remove the probe using an oven mitt.
- Clean the probe with water and a mild detergent.
- To clean the main unit and sensor, wipe with a damp cloth.

NOTE:

Do not clean the probe in a dishwasher or immerse the main unit or sensor in water.

PRECAUTIONS

- Do not subject the unit to excessive force, shock, dust, temperature or humidity.
- Do not cover the ventilation holes with any items such as newspapers, curtains etc.
- Do not immerse the unit in water. If you spill liquid over it, dry it immediately with a soft, lint-free cloth.
- Do not clean the unit with abrasive or corrosive materials.
- Do not attempt to service this unit. There are no user serviceable components.
- Only use fresh batteries.
- Properly dispose of old batteries. Be sure to recycle old batteries.
- Do not place unit in dishwasher.

Patent Pending
Model No. 40128
Made in China / Hecho en China
Distributed by / Distribuido por
© Blue Rhino Global Sourcing, Inc.
10 Hub Dr., Ste 101, Melville, NY 11747
1.888.398.8643 • MrBarBQ.com
Mr. Bar-B-Q is a registered trademark of Blue Rhino Global Sourcing, Inc.
Mr. Bar-B-Q es una marca comercial registrada de Blue Rhino Global Sourcing, Inc.

FCC STATEMENT

1. This device complies with Part 15 of the FCC Rules. Operation is subject to the following two conditions:

(1) This device may not cause harmful interference, and
(2) This device must accept any interference received, including interference that may cause undesired operation.

2. Changes or modifications not expressly approved by the party responsible for compliance could void the user's authority to operate the equipment.

This equipment has been tested and found to comply with the limits for a Class B digital device, pursuant to part 15 of the FCC Rules. These limits are designed to provide reasonable protection against harmful interference in a residential installation. This equipment generates, uses and can radiate radio frequency energy and, if not installed and used in accordance with the instructions, may cause harmful interference to radio communications. However, there is no guarantee that interference will not occur in a particular installation. If this equipment does cause harmful interference to radio or television reception, which can be determined by turning the equipment off and on, the user is encouraged to try to correct the interference by one or more of the following measures:

- Reorient or relocate the receiving antenna.
- Increase the separation between the equipment and receiver.
- Connect the equipment into an outlet on a circuit different from that to which the receiver is connected.
- Consult the dealer or an experienced radio/ TV technician for help.

FCC Radiation Exposure Statement:

This equipment complies with FCC radiation exposure requirement.

The device can be used in portable exposure condition without RF striction.