

FCC Measurement/Technical Report on

REFCON Wireless Hub

FCC ID: 2ARHA-C00030

IC: -

Test Report Reference: MDE_EMERS_2102_FCC_08

Test Laboratory:

7layers GmbH
Borsigstrasse 11
40880 Ratingen
Germany



Deutsche
Akkreditierungsstelle
D-PL-12140-01-01
D-PL-12140-01-02
D-PL-12140-01-03

Note:

The following test results relate only to the devices specified in this document. This report shall not be reproduced in parts without the written approval of the test laboratory.

7layers GmbH
Borsigstraße 11
40880 Ratingen, Germany
T +49 (0) 2102 749 0
F +49 (0) 2102 749 350

Geschäftsführer/
Managing Directors:
Frank Spiller
Bernhard Retka
Alexandre Norré-Oudard

Registergericht/registered:
Düsseldorf HRB 75554
USt-Id.-Nr./VAT-No. DE203159652
Steuer-Nr./TAX-No. 147/5869/0385

*a Bureau Veritas
Group Company*

www.7layers.com

Table of Contents

1 Applied Standards and Test Summary	3
1.1 Applied Standards	3
1.2 FCC-IC Correlation Table	4
1.3 Measurement Summary	4
2 Revision History / Signatures	6
3 Administrative Data	7
3.1 Testing Laboratory	7
3.2 Project Data	7
3.3 Applicant Data	7
3.4 Manufacturer Data	8
4 Test object Data	9
4.1 General EUT Description	9
4.2 EUT Main components	9
4.3 Ancillary Equipment	10
4.4 Auxiliary Equipment	10
4.5 EUT Setups	10
4.6 Operating Modes / Test Channels	11
4.7 Product labelling	11
5 Test Results	12
5.1 Conducted Emissions at AC mains	12
5.2 Radiated Emissions	15
6 Test Equipment	21
7 Antenna Factors, Cable Loss and Sample Calculations	26
7.1 LISN R&S ESH3-Z5 (150 kHz – 30 MHz)	26
7.2 Antenna R&S HFH2-Z2 (9 kHz – 30 MHz)	27
7.3 Antenna R&S HL562 (30 MHz – 1 GHz)	28
7.4 Antenna R&S HF907 (1 GHz – 18 GHz)	29
7.5 Antenna EMCO 3160-09 (18 GHz – 26.5 GHz)	30
7.6 Antenna EMCO 3160-10 (26.5 GHz – 40 GHz)	31
8 Measurement Uncertainties	32
9 Photo Report	33

1 APPLIED STANDARDS AND TEST SUMMARY

1.1 APPLIED STANDARDS

Applicable FCC Rules

Prepared in accordance with the requirements of FCC Rules and Regulations as listed in 47 CFR Ch.1 Parts 2 and 15 (10-1-19 Edition). The following subparts are applicable to the results in this test report.

Part 2, Subpart J - Equipment Authorization Procedures, Certification

Part 15, Subpart B – Unintentional Radiators

§ 15.107 Conducted limits

§ 15.109 Radiated emission limits; general requirements

Applicable ISED Standards

ICES-Gen, Issue 1

ICES-003, Issue 6

Note:

ANSI C63.4-2014 is applied.

1.2 FCC-IC CORRELATION TABLE

Correlation of measurement requirements for Information Technology Equipment (ITE) from FCC and IC

Measurement	FCC reference	IC reference
Conducted Emissions (AC Power Line)	§15.107	ICES-003 Issue 6: 6.1
Radiated Spurious Emissions	§15.109	ICES-003 Issue 6: 6.2

Remarks:

1. FCC Part 15 subpart B, ICES 003 and CISPR 22 contain different definitions of Class A and Class B limits, i.e. which class is applicable to which kind of EUT.
ICES 003 and CISPR 22 distinguish between the location where the EUT is intended to operate whilst FCC refers to the method of commercial distribution (distributive trades).
2. The correct assignment of the appropriate class to the concrete EUT is not scope of this test report!
3. A radio apparatus that is specifically subject to an Industry Canada Radio Standard Specification (RSS) and which contains an ITE is not subject to ICES-003 provided the ITE is used only to enable operation of the radio apparatus and the ITE does not control additional functions or capabilities.
4. ISM (Industrial, Scientific or Medical) radio frequency generators, though they may contain ITE, are excluded from the definition of ITE and are not subject to ICES-003. They are instead subject to the Interference-Causing Equipment Standard ICES-001, which specifically addresses ISM radio frequency generators.

1.3 MEASUREMENT SUMMARY

47 CFR CHAPTER I FCC PART 15 § 15.107 Class B
Subpart B

Conducted Emissions at AC mains

The measurement was performed according to ANSI C63.4

Final Result

OP-Mode	Setup	Date	FCC	IC
AC mains connection, Test setup via auxiliary equipment, computer peripheral	S01_AB01	2021-10-25	Passed	Passed

47 CFR CHAPTER I FCC PART 15 § 15.109 Class A
Subpart B

Radiated Emissions

The measurement was performed according to ANSI C63.4

Final Result

OP-Mode	Setup	Date	FCC	IC
AC mains connection, Measurement range, Test setup via auxiliary equipment, 1 GHz - 18 GHz, computer peripheral Remark: Class B	S01_AB01	2021-10-03	Passed	Passed
via auxiliary equipment, 30 MHz - 1 GHz, computer peripheral Remark: Class A	S01_AB01	2021-10-25	Passed	Passed

N/A: Not applicable
N/P: Not performed

2 REVISION HISTORY / SIGNATURES

Report version control			
Version	Release date	Change Description	Version validity
initial	2021-12-03	--	valid
--	--	--	--

COMMENT: -



(responsible for accreditation scope)
Marco Kullik



(responsible for testing and report)
Mohamed Fraitat



7 layers GmbH, Borsigstr. 11
40880 Ratingen, Germany
Phone +49 (0)2102 749 0

3 ADMINISTRATIVE DATA

3.1 TESTING LABORATORY

Company Name: 7layers GmbH
Address: Borsigstr. 11
40880 Ratingen
Germany

The test facility is accredited by the following accreditation organisation:

Laboratory accreditation no: DAKKS D-PL-12140-01-01 | -02 | -03
FCC Designation Number: DE0015
FCC Test Firm Registration: 929146
ISED CAB Identifier: DE0007; ISED#: 3699A

Responsible for accreditation scope: Marco Kullik
Report Template Version: 2021-09-09

3.2 PROJECT DATA

Responsible for testing and report: Mohamed Fraitat
Employees who performed the tests: documented internally at 7Layers
Date of Report: 2021-12-03
Testing Period: 2021-10-03 to 2021-10-25

3.3 APPLICANT DATA

Company Name: EMERSON Transportation Solutions ApS
Address: Boeletvej 1 Ry
DK-8680
Denmark
Contact Person: Jakob Riis Lorentsen

3.4 MANUFACTURER DATA

Company Name: please see Applicant Data

Address:

Contact Person:

4 TEST OBJECT DATA

4.1 GENERAL EUT DESCRIPTION

Kind of Device product description	The REFCON Wireless Hub is a device used to collect data from all current reefer types through the REFCON Portable Modem and Bluetooth enabled devices. All data is collected automatically and sent to the local REFCON system enabling onsite technicians to obtain a clear and precise overview of the status of all reefers within the site.
Product name	REFCON Wireless Hub
Type	8409-002
Declared EUT data by the supplier	
Power Supply Type	DC
Test Voltage / Frequency	24 V
Highest internal frequency	2480 MHz
Specific product description for the EUT	The EUT is a Bluetooth low energy transceiver.
Ports	<ul style="list-style-type: none"> - DC port (connected to power supply) - LAN port (connected to AUX 1) - USB port (connected to AUX 1) - Mini-USB (not connected)
Special software used for testing	-

4.2 EUT MAIN COMPONENTS

Sample Name	Sample Code	Description
ab01	DE1325005ab01	Radiated and conducted sample
Sample Parameter	Value	
Serial No.	ABE840900220280008	
HW Version	<ul style="list-style-type: none"> - Beagle Bone Black:rev C - Cape PBA rev C3. - BLE PBA rev 4.3 	
SW Version	<ul style="list-style-type: none"> - Beagle Bone Black: 9ac5067 - BLE PBA: 2a2b121 	
Comment	-	

NOTE:The short description is used to simplify the identification of the EUT in this test report.

4.3 ANCILLARY EQUIPMENT

For the purposes of this test report, ancillary equipment is defined as equipment which is used in conjunction with the EUT to provide operational and control features to the EUT. It is necessary to configure the system in a typical fashion, as a customer would normally use it. But nevertheless Ancillary Equipment can influence the test results.

Device	Details (Manufacturer, Type Model, OUT Code)	Description
-	-	-

4.4 AUXILIARY EQUIPMENT

For the purposes of this test report, auxiliary equipment is defined as equipment which is used temporarily to enable operational and control features especially used for the tests of the EUT which is not used during normal operation or equipment that is used during the tests in combination with the EUT but is not subject of this test report. It is necessary to configure the system in a typical fashion, as a customer would normally use it. But nevertheless Auxiliary Equipment can influence the test results.

Device	Details (Manufacturer, Type Model, HW, SW, S/N)	Description
AUX_05	, 2J662B-250LL100-C20N 15/ 19, -, -,	Ext Antenna 02 (2J66..)
AUX 2	Fujitsu, Lifebook E Series U758, -, -, DSAL006396	Laptop
AUX 3	Fujitsu, A13-065N3A, -, -, 184903C604	AC/DC Adapter for laptop
AUX 4	Logitech, M-BT58, -, -, HC60915A2XC	Mouse
AUX 5	Cherry, RS 6000 USB ON, -, -, G 0000273 2P28	Keyboard
AUX 6	LG, L17MB-P, -, -, 412WAPL0U560	Monitor

4.5 EUT SETUPS

This chapter describes the combination of EUTs and equipment used for testing. The rationale for selecting the EUTs, ancillary and auxiliary equipment and interconnecting cables, is to test a representative configuration meeting the requirements of the referenced standards.

Setup	Combination of EUTs	Description and Rationale
S01_AB01	ab01, AUX_03, AUX 2 to AUX 6	Setup for radiated measurement

4.6 OPERATING MODES / TEST CHANNELS

This chapter describes the operating modes of the EUTs used for testing.

- Bluetooth low energy local RX CH19
- LAN PING
- USB traffic

4.7 PRODUCT LABELLING

4.7.1 FCC ID LABEL

Please refer to the documentation of the applicant.

4.7.2 LOCATION OF THE LABEL ON THE EUT

Please refer to the documentation of the applicant.

5 TEST RESULTS

5.1 CONDUCTED EMISSIONS AT AC MAINS

Standard **FCC Part 15 Subpart B**

The test was performed according to:
ANSI C63.4

5.1.1 TEST DESCRIPTION

The test set-up was made in accordance to the general provisions of ANSI C 63.4. The Equipment Under Test (EUT) was setup in a shielded room to perform the conducted emissions measurements in a typical installation configuration. The EUT was powered from 50 μ H || 50 Ohm Line Impedance Stabilization Network (LISN). The LISN's unused connections were terminated with 50 Ohm loads.

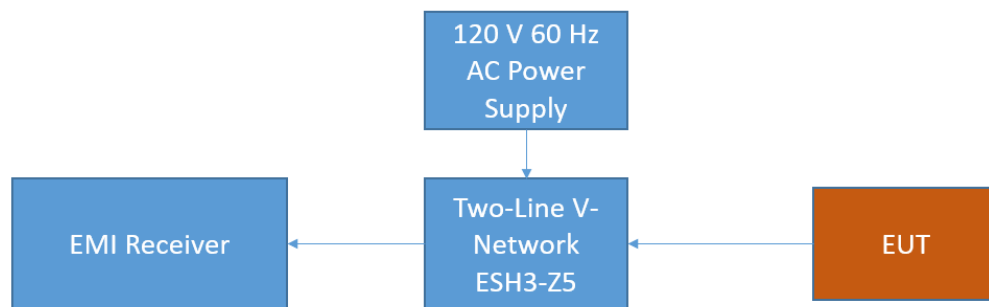

FCC Conducted Emissions on AC

The measurement procedure consists of two steps. It is implemented into the EMI test software EMC-32 from R&S.

Step 1: Preliminary scan

Intention of this step is, to determine the conducted EMI-profile of the EUT.

EMI receiver settings:

- Detector: Peak – Maxhold & Average
- Frequency range: 150 kHz – 30 MHz
- Frequency steps: 2.5 kHz
- IF-Bandwidth: 9 kHz
- Measuring time / Frequency step: 100 ms (FFT-based)
- Measurement on phase + neutral lines of the power cords

On basis of this preliminary scan the highest amplitudes and the corresponding frequencies relative to the limit are identified. Emissions above the limit and emissions which are in the 10 dB range below the limit are considered.

Step 2: Final measurement

Intention of this step is, to determine the highest emissions with the settings defined in the test specification for the frequencies identified in step 1.

EMI receiver settings:

- Detector: Quasi-Peak & (CISPR) Average

- IF Bandwidth: 9 kHz
- Measuring time: 1 s / frequency

At each frequency determined in step 1, four measurements are performed in the following combinations:

- 1) Neutral lead - reference ground (PE grounded)
- 2) Phase lead - reference ground (PE grounded)
- 3) Neutral lead - reference ground (PE floating)
- 4) Phase lead - reference ground (PE floating)

The highest value is reported.

5.1.2 TEST REQUIREMENTS / LIMITS

FCC Part 15, Subpart B, §15.107

Class B:

Frequency (MHz)	QP Limits (dBµV)	AV Limits (dBµV)
0.15 - 0.5	66 - 56	56 - 46
0.5 - 5	56	46
5 - 30	60	50

Class A:

Frequency (MHz)	QP Limits (dBµV)	AV Limits (dBµV)
0.15 - 0.5	79	66
0.5 - 30	73	60

5.1.3 TEST PROTOCOL

Temperature: 24 °C
 Air Pressure: 1002 hPa
 Humidity: 40 %

via auxiliary equipment, computer peripheral

Power line	PE	Frequency [MHz]	Level [dBµV]	Detector	Limit [dBµV]	Margin [dB]
L1	GND	0.7	26.3	AV	46.00	19.7
L1	GND	1.1	30.4	AV	46.00	15.6
L1	GND	1.5	34.5	AV	46.00	11.5
L1	GND	1.5	41.6	QP	56.00	14.4
L1	GND	2.2	28.6	AV	46.00	17.4
N	FLO	24.0	30.4	AV	50.00	19.6

Remark: Please see next sub-clause for the measurement plot.

5.1.4 MEASUREMENT PLOT (EXAMPLE PLOT, SHOWING WORST CASE, IF APPLICABLE)

Diagram 1.01

Common Information

Test Description:	Conducted Emissions
Test Standard:	FCC §15.107 Class B
EUT / Setup Code:	DE1325005ab01
Operating Conditions:	120 V 60 Hz, BTLERX, DC Powered
Operator Name:	CAP
Comment:	-
Legend:	Trace: blue = QP, green = CISPR AV; Star: red or blue = critical frequency; Rhombus: blue = final QP, green = final CISPR AV
Tested Port / used LISN:	AC mains => 1st LISN ESH3-Z5
Termination of other ports:	AC of AUX => 2nd LISN ESH3-Z5 +50 Ohm

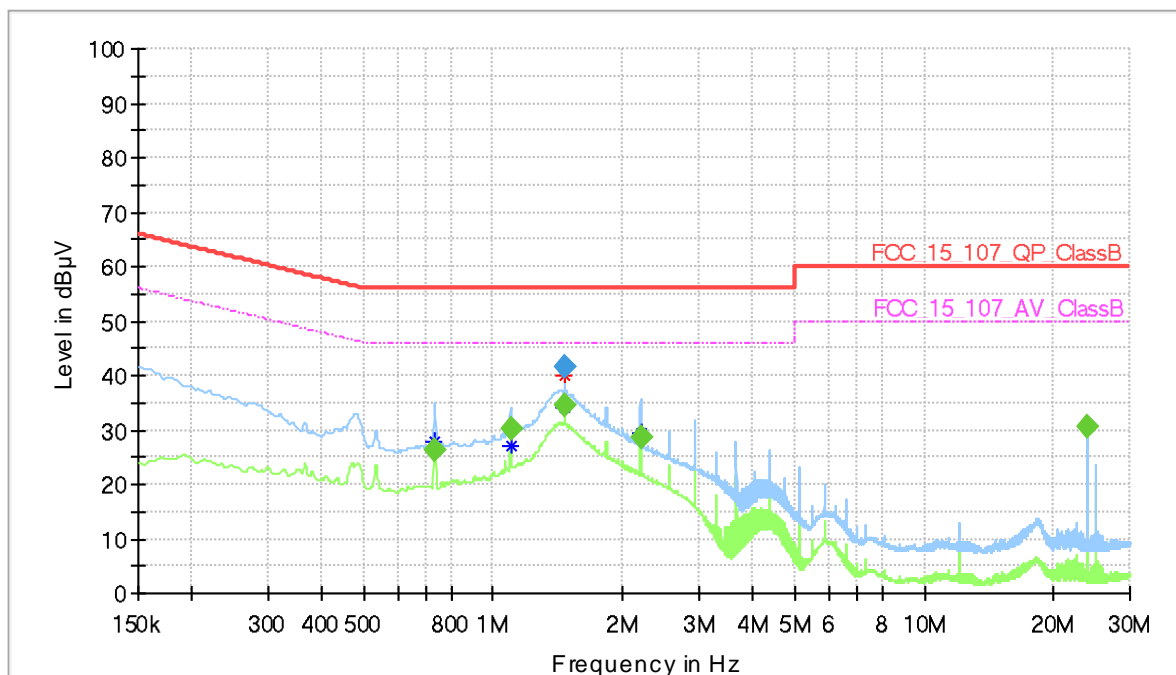

Final Result

Frequency (MHz)	QuasiPeak (dBµV)	CAverage (dBµV)	Limit (dBµV)	Margin (dB)	Meas. Time	Bandwidth (kHz)	Line	PE	Corr. (dB)
0.732750	---	26.28	46.00	19.72	1000.0	9.000	L1	GND	10.1
1.097250	---	30.37	46.00	15.63	1000.0	9.000	L1	GND	10.1
1.464000	---	34.46	46.00	11.54	1000.0	9.000	L1	GND	10.2
1.464000	41.61	---	56.00	14.39	1000.0	9.000	L1	GND	10.2
2.195250	---	28.58	46.00	17.42	1000.0	9.000	L1	GND	10.2
24.002250	---	30.55	50.00	19.45	1000.0	9.000	N	FLO	11.2

5.1.5 TEST EQUIPMENT USED

- Conducted Emissions FCC

5.2 RADIATED EMISSIONS

Standard **FCC Part 15 Subpart B**

The test was performed according to:
ANSI C63.4

5.2.1 TEST DESCRIPTION

The test set-up was made in accordance to the general provisions of ANSI C63.4 in a typical installation configuration. The measurements were performed according the following sub-chapters of ANSI C63.4:

- 30 MHz – 1 GHz: Chapter 8.3.2.1
- > 1 GHz: Chapter 8.3.2.2

The measurement procedure is implemented into the EMI test software EMC32 from R&S. Exploratory tests are performed at 3 orthogonal axes to determine the worst-case orientation of a body-worn or handheld EUT. The final test on all kind of EUTs is also performed at 3 axes. A pre-check is performed while the EUT is powered.

The Equipment Under Test (EUT) was set up on a non-conductive table in the semi-anechoic chamber. The influence of the EUT support table that is used between 30–1000 MHz was evaluated.

1. Measurement setup

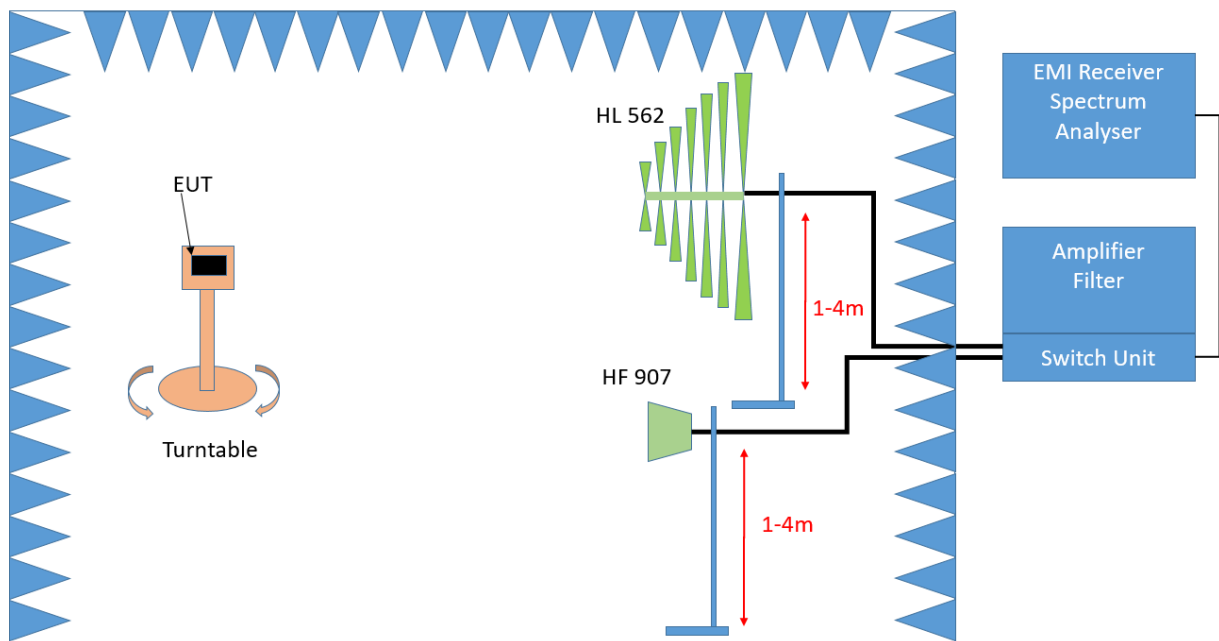

Test Setup; Spurious Emission Radiated (SAC)

Frequency range 30 MHz – 1 GHz

Step 1: Preliminary scan

This is a preliminary test to identify the highest amplitudes relative to the limit.

Settings for step 1:

- Antenna distance: 3 m
- Detector: Peak-Maxhold / Quasipeak (FFT-based)
- Frequency range: 30 – 1000 MHz
- Frequency steps: 30 kHz
- IF-Bandwidth: 120 kHz
- Measuring time / Frequency step: 100 ms
- Turntable angle range: -180° to 90°
- Turntable step size: 90°
- Height variation range: 1 – 4 m
- Height variation step size: 1.5 m
- Polarisation: Horizontal + Vertical

Intention of this step is, to determine the radiated EMI-profile of the EUT. Afterwards the relevant emissions for the final measurement are identified.

Step 2: Adjustment measurement

In this step the accuracy of the turntable azimuth and antenna height will be improved. This is necessary to find out the maximum value of every frequency.

For each frequency, which was determined the turntable azimuth and antenna height will be adjusted. The turntable azimuth will slowly vary by 360° . During this action, the value of emission is continuously measured. The turntable azimuth at the highest emission will be recorded and adjusted. In this position, the antenna height will slowly vary between 1 – 4 m. During this action, the value of emission is also continuously measured. The antenna height of the highest emission will also be recorded and adjusted.

- Detector: Peak – Maxhold
- Measured frequencies: in step 1 determined frequencies
- IF – Bandwidth: 120 kHz
- Measuring time: 100 ms
- Turntable angle range: 360°
- Height variation range: 1 – 4 m
- Antenna Polarisation: max. value determined in step 1

Step 3: Final measurement with QP detector

With the settings determined in step 2, the final measurement will be performed:

EMI receiver settings for step 3:

- Detector: Quasi-Peak
- Measured frequencies: in step 1 determined frequencies
- IF – Bandwidth: 120 kHz
- Measuring time: 1 s

Above 1 GHz:

The following changes apply to the measurement procedure for the frequency range > 1 GHz:

Step 1:

- Turntable step size: 45°
- Detector: Peak, Average (Maxhold)
- IF – Bandwidth: 1 MHz
- Frequency steps: 250 kHz
- Measuring time: 500 ms / GHz

Step 2:

- IF – Bandwidth: 1 MHz

Step 3:

- Detector: Peak / CISPR Average
- IF – Bandwidth: 1 MHz

After every measurement a plot will be generated which contains a diagram with the results of the preliminary scan and a chart with the frequencies and values of the results of the final measurement.

5.2.2 TEST REQUIREMENTS / LIMITS

FCC Part 15, Subpart B, §15.109, Radiated Emission Limits

Class B:

Frequency (MHz)	Limit (µV/m)	Measurement distance (m)	Limits (dBµV/m)
30 – 88	100@3m	3	40.0@3m
88 – 216	150@3m	3	43.5@3m
216 – 960	200@3m	3	46.0@3m
960 – 26000	500@3m	3	54.0@3m
26000 – 40000	500@3m	1	54.0@3m

Class A:

Frequency (MHz)	Limit (µV/m)	Measurement distance (m)	Limits (dBµV/m)
30 – 88	90@10m	3	39.1@10m
88 – 216	150@10m	3	43.5@10m
216 – 960	210@10m	3	46.4@10m
960 – 26000	300@10m	3	49.5@10m
26000 – 40000	300@10m	1	49.5@10m

The measured values for Class A and for Class B (> 26 GHz) measurements are corrected with an inverse linear distance extrapolation factor (20 dB/decade).

§15.35(b) ..., there is also a limit on the radio frequency emissions, as measured using instrumentation with a peak detector function, corresponding to 20 dB above the maximum permitted average limit....

Used conversion factor: $\text{Limit (dBµV/m)} = 20 \log (\text{Limit (µV/m)}/1µV/m)$

5.2.3 TEST PROTOCOL

Ambient temperature: 24 °C
 Air Pressure: 1003 hPa
 Humidity: 42 %
 via auxiliary equipment, computer peripheric

Spurious Freq. [MHz]	Spurious Level [dB μ V/m]	Detector	RBW [kHz]	Limit [dB μ V/m]	Margin to Limit [dB]
4799.8	54.0	PEAK	1000	74.0	20.0
4799.8	27.9	AV	1000	54.0	26.1
5994.3	59.6	PEAK	1000	74.0	14.4
5994.3	27.9	AV	1000	54.0	26.1
144.0	40.9	QP	120	43.5	2.6
240.0	38.4	QP	120	46.0	8.1
336.0	41.6	QP	120	46.0	4.8
432.0	18.4	QP	120	46.0	28.1
528.0	44.9	QP	120	46.0	1.5
720.0	45.6	QP	120	46.0	0.8

Remark: Please see next sub-clause for the measurement plot.

5.2.4 MEASUREMENT PLOT (EXAMPLE PLOT, SHOWING WORST CASE, IF APPLICABLE)

Diagram 2.01

Common Information

Test Description: Radiated Emissions, Test Site: Semi Anechoic Chamber @ 4 m
 Test Standard: FCC 15 B Class A
 EUT / Setup Code: DE1325005ab01
 Operating Conditions: 24 V, EUT powered via DC, USB connected, LAN connected
 Operator Name: CAP
 Comment: External Antenna with short cable,

Legend: Trace (preview): blue = PK, green = QP; Star: red or blue = critical frequency; Rhombus: blue = final QP
 Distance Corr. 3 m/10 m 10.5 dB subtracted from measurement value(s)

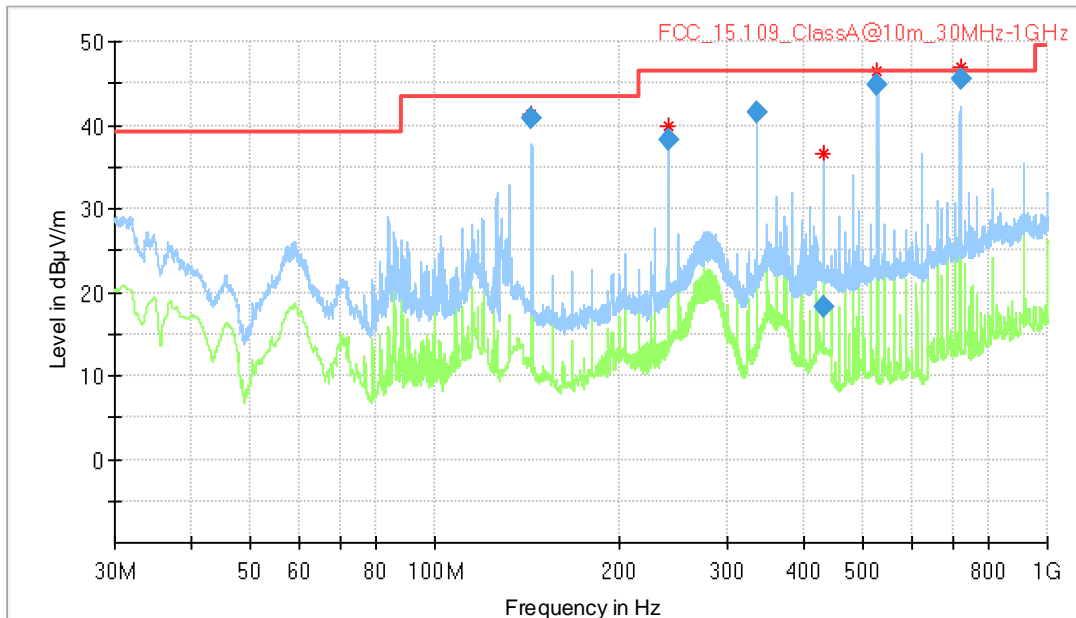

Final Result

Frequency (MHz)	QuasiPeak (dBµV/m)	Limit (dBµV/m)	Margin (dB)	Meas. Time (ms)	Bandwidth (kHz)	Height (cm)	Pol	Azimuth (deg)	Corr. (dB/m)
144.000000	40.92	43.50	2.58	1000.0	120.000	201.0	H	92.0	-1.0
240.000000	38.35	46.40	8.05	1000.0	120.000	213.0	H	-8.0	1.0
336.000000	41.58	46.40	4.82	1000.0	120.000	112.0	H	112.0	4.4
432.030000	18.35	46.40	28.05	1000.0	120.000	329.0	V	-163.0	6.9
528.030000	44.89	46.40	1.51	1000.0	120.000	293.0	H	-9.0	8.9
720.030000	45.64	46.40	0.76	1000.0	120.000	202.0	V	146.0	12.2

Diagram 2.02

Common Information

Test Description:	Radiated Emissions @ 3 m, SAC + mobile floor absorber
Test Standard:	FCC 15 B Class B
EUT / Setup Code:	DE1325005ab01
Operating Conditions:	BTLERX, LAN Ping
Operator Name:	CAP
Comment:	-
Legend:	Trace (preview): blue = PK, green = AV; Star: red or blue = critical frequency; Rhombus: blue = final Peak, green = Final CISPR AV

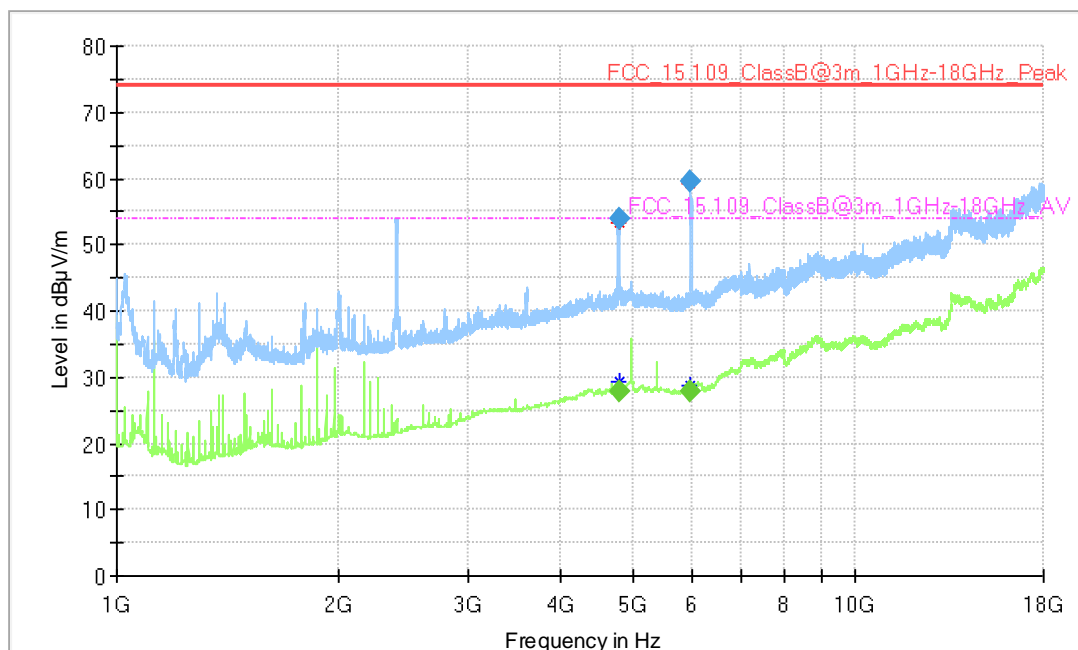

Final Result

Frequency (MHz)	MaxPeak (dBuV/m)	CAverage (dBuV/m)	Limit (dBuV/m)	Margin (dB)	Meas. Time (ms)	Bandwidth (kHz)	Height (cm)	Pol	Azimuth (deg)	Corr. (dB/m)
4799.750000	54.01	---	74.00	19.99	200.0	1000.000	278.0	V	-94.0	13.8
4799.750000	---	27.94	54.00	26.06	200.0	1000.000	262.0	H	50.0	13.8
5994.250000	59.57	---	74.00	14.43	200.0	1000.000	262.0	H	50.0	15.0
5994.250000	---	27.93	54.00	26.07	200.0	1000.000	262.0	H	50.0	15.0

5.2.5 TEST EQUIPMENT USED

- Radiated Emissions

6 TEST EQUIPMENT

- 1 Conducted Emissions FCC
Conducted Emissions AC Mains for FCC standards

Ref.No.	Device Name	Description	Manufacturer	Serial Number	Last Calibration	Calibration Due
1.1	MFS	Rubidium Frequency Normal MFS	Datum GmbH	002	2020-11	2021-11
1.2	Opus10 TPR (8253.00)	T/P Logger 13	Lufft Mess- und Regeltechnik GmbH	13936		
1.3	SMBV100A	Vector Signal Generator 9 kHz - 3.2 GHz (GNSS / Broadcast Signalling Unit)	Rohde & Schwarz GmbH & Co. KG	260001	2021-02	2024-02
1.4	ESH3-Z5	Two-Line V-Network (AUX)	Rohde & Schwarz GmbH & Co. KG	828304/029	2021-08	2023-08
1.5	EP 1200/B, NA/B1	AC Source, Amplifier with integrated variable Oscillator	Spitzenberger & Spies GmbH & Co. KG	B6278		
1.6	CMU 200	"CMU2" Universal Radio Communication Tester	Rohde & Schwarz	837983/052		
1.7	Chroma 6404	AC Source	Chroma ATE INC.	64040001304		
1.8	CMW500	Callbox OIL-RE, SUW	Rohde & Schwarz GmbH & Co. KG	155999-Ei	2019-09	2022-09
1.9	CMU 200	"CMU1" Universal Radio Communication Tester	Rohde & Schwarz GmbH & Co. KG	102366	2021-02	2024-02
1.10	CBT	Bluetooth Tester "CBT-02" incl. BLE-Option	Rohde & Schwarz	100302	2021-05	2024-05
1.11	CMW500	Callbox OIL-RE, SUA	Rohde & Schwarz GmbH & Co. KG	163529-bw	2020-07	2023-07
1.12	Shielded Room 02	Shielded Room 4m x 3m	Frankonia Germany EMC Solution GmbH	-		
1.13	CMW500	Callbox OIL-RE, SUA-160 MHz	Rohde & Schwarz GmbH & Co. KG	168927-cv	2020-05	2023-05
1.14	CMD 55	Digital Radio Communication Tester	Rohde & Schwarz	831050/020		
1.15	ESH3-Z5	Two-Line V-Network (EUT)	Rohde & Schwarz GmbH & Co. KG	829996/002	2021-08	2023-08
1.16	ESR 7	EMI Receiver / Spectrum Analyzer	Rohde & Schwarz	101424	2021-01	2023-01

Ref.No.	Device Name	Description	Manufacturer	Serial Number	Last Calibration	Calibration Due
1.17	CMW500	Callbox OIL-RE, SUA-160 MHz	Rohde & Schwarz GmbH & Co. KG	167766-By	2019-07	2022-07
1.18	Opus10 THI (8152.00)	T/H Logger 02	Lufft Mess- und Regeltechnik GmbH	7489		
1.19	SMU 200A	Vector Signal Generator (GPS Signalling Unit)	Rohde & Schwarz GmbH & Co. KG	100912		
1.20	CMW 500	Wideband Radio communication Tester	Rohde & Schwarz	107500		
1.21	CBT	Bluetooth Tester "CBT-01"	Rohde & Schwarz GmbH & Co. KG	100589	2021-09	2024-09

2 Radiated Emissions
Lab to perform radiated emission tests

Ref.No.	Device Name	Description	Manufacturer	Serial Number	Last Calibration	Calibration Due
2.1	MFS	Rubidium Frequency Normal MFS	Datum GmbH	002	2020-11	2021-11
2.2	N5000/NP	Filter for EUT, 2 Lines, 250 V, 16 A	ETS-LINDGREN	241515		
2.3	Opus10 TPR (8253.00)	T/P Logger 13	Lufft Mess- und Regeltechnik GmbH	13936		
2.4	ESW44	EMI Receiver / Spectrum Analyzer	Rohde & Schwarz GmbH & Co. KG	101603	2019-12	2021-12
2.5	Anechoic Chamber 01	SAC/FAR, 10.58 m x 6.38 m x 6.00 m	Frankonia	none		
2.6	FS-Z60	Harmonic Mixer 40 - 60 GHz	Rohde & Schwarz Messgerätebau GmbH	100178	2020-03	2023-03
2.7	FS-Z220	Harmonic Mixer 140 - 220 GHz	Rohde & Schwarz Messgerätebau GmbH	101005	2020-03	2023-03
2.8	SGH-05	Standard Gain / Pyramidal Horn Antenna (140 - 220 GHz)	RPG-Radiometer Physics GmbH	075		
2.9	HL 562 ULTRALOG	Biconical-log-per antenna (30 MHz - 3 GHz) with HL 562E biconicals	Rohde & Schwarz GmbH & Co. KG	830547/003	2021-09	2024-09
2.10	AMF-7D00101800-30-10P-R	Broadband Amplifier 100 MHz - 18 GHz	Miteq			

Ref.No.	Device Name	Description	Manufacturer	Serial Number	Last Calibration	Calibration Due
2.11	5HC2700/12750-1.5-KK	High Pass Filter	Trilithic	9942012		
2.12	ASP 1.2/1.8-10 kg	Antenna Mast	Maturo GmbH	-		
2.13	Anechoic Chamber 03	FAR, 8.80m x 4.60m x 4.05m (l x w x h)	Albatross Projects	P26971-647-001-PRB	2021-04	2023-04
2.14	Fluke 177	Digital Multimeter 03 (Multimeter)	Fluke Europe B.V.	86670383	2020-04	2022-04
2.15	Opus10 THI (8152.00)	T/H Logger 10	Lufft Mess- und Regeltechnik GmbH	12488	2021-08	2023-08
2.16	PONTIS Con4101	PONTIS Camera Controller		6061510370		
2.17	NRVD	Power Meter	Rohde & Schwarz GmbH & Co. KG	828110/016	2021-09	2022-09
2.18	HF 906	Double-ridged horn	Rohde & Schwarz	357357/002		
2.19	JS4-18002600-32-5P	Broadband Amplifier 18 GHz - 26 GHz	Miteq	849785		
2.20	FSW 43	Spectrum Analyzer	Rohde & Schwarz	103779	2021-06	2023-06
2.21	EP 1200/B, NA/B1	AC Source, Amplifier with integrated variable Oscillator	Spitzenberger & Spies GmbH & Co. KG	B6278		
2.22	3160-09	Standard Gain / Pyramidal Horn Antenna 26.5 GHz	EMCO Elektronik GmbH	00083069		
2.23	SGH-19	Standard Gain / Pyramidal Horn Antenna (40 - 60 GHz)	RPG-Radiometer Physics GmbH	093		
2.24	WHKX 7.0/18G-8SS	High Pass Filter	Wainwright Instruments GmbH	09		
2.25	DS 420S	Turn Table 2 m diameter	HD GmbH	420/573/99		
2.26	4HC1600/12750-1.5-KK	High Pass Filter	Trilithic	9942011		
2.27	Temperature Chamber KWP 120/70	Temperature Chamber Weiss 01	Weiss	59226012190010	2020-05	2022-05
2.28	JS4-00102600-42-5A	Broadband Amplifier 30 MHz - 26 GHz	Miteq	619368		
2.29	TT 1.5 WI	Turn Table	Maturo GmbH	-		
2.30	HL 562 ULTRALOG	Biconical-log-per Antenna (30 MHz - 3 GHz)	Rohde & Schwarz GmbH & Co. KG	100609	2019-05	2022-05
2.31	HF 906	Double-ridged horn	Rohde & Schwarz	357357/001	2021-08	2024-08

Ref.No.	Device Name	Description	Manufacturer	Serial Number	Last Calibration	Calibration Due
2.32	FS-Z325	Harmonic Mixer 220 - 325 GHz	Rohde & Schwarz Messgerätebau GmbH	101006	2020-03	2023-03
2.33	CMW500	Callbox OIL-RE, SUW	Rohde & Schwarz GmbH & Co. KG	155999-Ei	2019-09	2022-09
2.34	CMU 200	"CMU1" Universal Radio Communication Tester	Rohde & Schwarz GmbH & Co. KG	102366	2021-02	2024-02
2.35	3160-10	Standard Gain / Pyramidal Horn Antenna 40 GHz	EMCO Elektronik GmbH	00086675		
2.36	MA4985-XP-ET	Bore Sight Antenna Mast	innco systems GmbH	none		
2.37	SGH-08	Standard Gain / Pyramidal Horn Antenna (90 - 140 GHz)	RPG-Radiometer Physics GmbH	064		
2.38	Temperature Chamber VT 4002	Temperature Chamber Vötsch 03	Vötsch	58566002150010	2020-05	2022-05
2.39	CBT	Bluetooth Tester "CBT-02" incl. BLE-Option	Rohde & Schwarz	100302	2021-05	2024-05
2.40	CMW500	Callbox OIL-RE, SUA	Rohde & Schwarz GmbH & Co. KG	163529-bw	2020-07	2023-07
2.41	CMW500	Callbox OIL-RE, SUA-160 MHz	Rohde & Schwarz GmbH & Co. KG	168927-cv	2020-05	2023-05
2.42	SGH-12	Standard Gain / Pyramidal HornAntenna (60 - 90 GHz)	RPG-Radiometer Physics GmbH	326		
2.43	VLFX-650+	Low Pass Filter DC650 MHz	Mini-Circuits	15542		
2.44	JUN-AIR Mod. 6-15	Air Compressor	JUN-AIR Deutschland GmbH	612582		
2.45	5HC3500/18000-1.2-KK	High Pass Filter	Trilithic	200035008		
2.46	FS-Z140	Harmonic Mixer 90 -140 GHz	Rohde & Schwarz Messgerätebau GmbH	101007	2020-03	2023-03
2.47	HFH2-Z2	Loop Antenna + 3 Axis Tripod	Rohde & Schwarz GmbH & Co. KG	829324/006	2021-01	2024-01
2.48	Voltcraft M-3860M	Digital Multimeter 01 (Multimeter)	Conrad	IJ096055		
2.49	ESR 7	EMI Receiver / Spectrum Analyzer	Rohde & Schwarz	101424	2021-01	2023-01

Ref.No.	Device Name	Description	Manufacturer	Serial Number	Last Calibration	Calibration Due
2.50	SB4-100.OLD20-3T/10 Airwin 2 x 1.5 kW	Air compressor (oil-free)	airWin Kompressoren UG	901/00503		
2.51	UNI-T UT195E	True RMS Digital Multimeter	UNI-T UNI-TREND TECHNOLOGY (CHINA) CO., LTD.	C190729561		
2.52	JS4-00101800-35-5P	Broadband Amplifier 30 MHz - 18 GHz	Miteq	896037		
2.53	AS 620 P	Antenna Mast (pneumatic polarisation)	HD GmbH	620/37		
2.54	CMW500	Callbox OIL-RE, SUA-160 MHz	Rohde & Schwarz GmbH & Co. KG	167766-By	2019-07	2022-07
2.55	6005D (30 V / 5 A)	Laboratory Power Supply 120 V 60 Hz	PeakTech	81062045		
2.56	TD1.5-10kg	EUT Tilt Device (Rohacell)	Maturo GmbH	TD1.5-10kg/024/3790709		
2.57	SGH-03	Standard Gain / Pyramidal Horn Antenna (220 - 325 GHz)	RPG-Radiometer Physics GmbH	060		
2.58	FS-Z90	Harmonic Mixer 60 - 90 GHz	Rohde & Schwarz Messgerätebau GmbH	101686	2020-03	2023-03
2.59	Innco Systems CO3000	Controller for bore sight mast SAC	innco systems GmbH	CO3000/967/39371016/L		
2.60	NRV-Z1	Sensor Head B	Rohde & Schwarz GmbH & Co. KG	827753/006	2021-09	2022-09
2.61	HF 907-2	Double-ridged horn	Rohde & Schwarz	102817	2019-04	2022-04
2.62	PAS 2.5 - 10 kg	Antenna Mast	Maturo GmbH	-		
2.63	AFS42-00101800-25-S-42	Broadband Amplifier 25 MHz - 18 GHz	Miteq	2035324		
2.64	AM 4.0	Antenna Mast 4 m	Maturo GmbH	AM4.0/180/11920513		
2.65	HF 907	Double-ridged horn	Rohde & Schwarz	102444	2021-09	2024-09

The calibration interval is the time interval between "Last Calibration" and "Calibration Due"

7 ANTENNA FACTORS, CABLE LOSS AND SAMPLE CALCULATIONS

This chapter contains the antenna factors with their corresponding path loss of the used measurement path for all antennas as well as the insertion loss of the LISN.

7.1 LISN R&S ESH3-Z5 (150 KHZ – 30 MHZ)

Frequency MHz	Corr. dB	LISN insertion loss ESH3- Z5 dB	cable loss (incl. 10 dB atten- uator) dB
0.15	10.1	0.1	10.0
5	10.3	0.1	10.2
7	10.5	0.2	10.3
10	10.5	0.2	10.3
12	10.7	0.3	10.4
14	10.7	0.3	10.4
16	10.8	0.4	10.4
18	10.9	0.4	10.5
20	10.9	0.4	10.5
22	11.1	0.5	10.6
24	11.1	0.5	10.6
26	11.2	0.5	10.7
28	11.2	0.5	10.7
30	11.3	0.5	10.8

Sample calculation

$$U_{\text{LISN}} (\text{dB } \mu\text{V}) = U (\text{dB } \mu\text{V}) + \text{Corr. (dB)}$$

U = Receiver reading

LISN Insertion loss = Voltage Division Factor of LISN

Corr. = sum of single correction factors of used LISN, cables, switch units (if used)

Linear interpolation will be used for frequencies in between the values in the table.

7.2 ANTENNA R&S HFH2-Z2 (9 KHZ – 30 MHZ)

Frequency MHz	AF HFH-Z2) dB (1/m)	Corr. dB	cable loss 1 (inside chamber) dB	cable loss 2 (outside chamber) dB	cable loss 3 (switch unit) dB	cable loss 4 (to receiver) dB	distance corr. (-40 dB/ decade) dB	d _{Limit} (meas. distance (limit) m	d _{used} (meas. distance (used) m
0.009	20.50	-79.6	0.1	0.1	0.1	0.1	-80	300	3
0.01	20.45	-79.6	0.1	0.1	0.1	0.1	-80	300	3
0.015	20.37	-79.6	0.1	0.1	0.1	0.1	-80	300	3
0.02	20.36	-79.6	0.1	0.1	0.1	0.1	-80	300	3
0.025	20.38	-79.6	0.1	0.1	0.1	0.1	-80	300	3
0.03	20.32	-79.6	0.1	0.1	0.1	0.1	-80	300	3
0.05	20.35	-79.6	0.1	0.1	0.1	0.1	-80	300	3
0.08	20.30	-79.6	0.1	0.1	0.1	0.1	-80	300	3
0.1	20.20	-79.6	0.1	0.1	0.1	0.1	-80	300	3
0.2	20.17	-79.6	0.1	0.1	0.1	0.1	-80	300	3
0.3	20.14	-79.6	0.1	0.1	0.1	0.1	-80	300	3
0.49	20.12	-79.6	0.1	0.1	0.1	0.1	-80	300	3
0.490001	20.12	-39.6	0.1	0.1	0.1	0.1	-40	30	3
0.5	20.11	-39.6	0.1	0.1	0.1	0.1	-40	30	3
0.8	20.10	-39.6	0.1	0.1	0.1	0.1	-40	30	3
1	20.09	-39.6	0.1	0.1	0.1	0.1	-40	30	3
2	20.08	-39.6	0.1	0.1	0.1	0.1	-40	30	3
3	20.06	-39.6	0.1	0.1	0.1	0.1	-40	30	3
4	20.05	-39.5	0.2	0.1	0.1	0.1	-40	30	3
5	20.05	-39.5	0.2	0.1	0.1	0.1	-40	30	3
6	20.02	-39.5	0.2	0.1	0.1	0.1	-40	30	3
8	19.95	-39.5	0.2	0.1	0.1	0.1	-40	30	3
10	19.83	-39.4	0.2	0.1	0.2	0.1	-40	30	3
12	19.71	-39.4	0.2	0.1	0.2	0.1	-40	30	3
14	19.54	-39.4	0.2	0.1	0.2	0.1	-40	30	3
16	19.53	-39.3	0.3	0.1	0.2	0.1	-40	30	3
18	19.50	-39.3	0.3	0.1	0.2	0.1	-40	30	3
20	19.57	-39.3	0.3	0.1	0.2	0.1	-40	30	3
22	19.61	-39.3	0.3	0.1	0.2	0.1	-40	30	3
24	19.61	-39.3	0.3	0.1	0.2	0.1	-40	30	3
26	19.54	-39.3	0.3	0.1	0.2	0.1	-40	30	3
28	19.46	-39.2	0.3	0.1	0.3	0.1	-40	30	3
30	19.73	-39.1	0.4	0.1	0.3	0.1	-40	30	3

Sample calculation

$$E \text{ (dB } \mu\text{V/m)} = U \text{ (dB } \mu\text{V)} + AF \text{ (dB 1/m)} + Corr. \text{ (dB)}$$

U = Receiver reading

AF = Antenna factor

Corr. = sum of single correction factors of used cables, switch unit, distance correction, amplifier (if applicable)

distance correction = $-40 * \text{LOG} (d_{\text{Limit}} / d_{\text{used}})$

Linear interpolation will be used for frequencies in between the values in the table.

Table shows an extract of values

7.3 ANTENNA R&S HL562 (30 MHz – 1 GHz)

($d_{Limit} = 3\text{ m}$)

Frequency	AF R&S HL562	Corr.
MHz	dB (1/m)	dB
30	18.6	0.6
50	6.0	0.9
100	9.7	1.2
150	7.9	1.6
200	7.6	1.9
250	9.5	2.1
300	11.0	2.3
350	12.4	2.6
400	13.6	2.9
450	14.7	3.1
500	15.6	3.2
550	16.3	3.5
600	17.2	3.5
650	18.1	3.6
700	18.5	3.6
750	19.1	4.1
800	19.6	4.1
850	20.1	4.4
900	20.8	4.7
950	21.1	4.8
1000	21.6	4.9

cable loss 1 (inside chamber)	cable loss 2 (outside chamber)	cable loss 3 (switch unit)	cable loss 4 (to receiver)	distance corr. (-20 dB/decade)	d_{Limit} (meas. distance (limit))	d_{used} (meas. distance (used))
dB	dB	dB	dB	dB	m	m
0.29	0.04	0.23	0.02	0.0	3	3
0.39	0.09	0.32	0.08	0.0	3	3
0.56	0.14	0.47	0.08	0.0	3	3
0.73	0.20	0.59	0.12	0.0	3	3
0.84	0.21	0.70	0.11	0.0	3	3
0.98	0.24	0.80	0.13	0.0	3	3
1.04	0.26	0.89	0.15	0.0	3	3
1.18	0.31	0.96	0.13	0.0	3	3
1.28	0.35	1.03	0.19	0.0	3	3
1.39	0.38	1.11	0.22	0.0	3	3
1.44	0.39	1.20	0.19	0.0	3	3
1.55	0.46	1.24	0.23	0.0	3	3
1.59	0.43	1.29	0.23	0.0	3	3
1.67	0.34	1.35	0.22	0.0	3	3
1.67	0.42	1.41	0.15	0.0	3	3
1.87	0.54	1.46	0.25	0.0	3	3
1.90	0.46	1.51	0.25	0.0	3	3
1.99	0.60	1.56	0.27	0.0	3	3
2.14	0.60	1.63	0.29	0.0	3	3
2.22	0.60	1.66	0.33	0.0	3	3
2.23	0.61	1.71	0.30	0.0	3	3

($d_{Limit} = 10\text{ m}$)

30	18.6	-9.9
50	6.0	-9.6
100	9.7	-9.2
150	7.9	-8.8
200	7.6	-8.6
250	9.5	-8.3
300	11.0	-8.1
350	12.4	-7.9
400	13.6	-7.6
450	14.7	-7.4
500	15.6	-7.2
550	16.3	-7.0
600	17.2	-6.9
650	18.1	-6.9
700	18.5	-6.8
750	19.1	-6.3
800	19.6	-6.3
850	20.1	-6.0
900	20.8	-5.8
950	21.1	-5.6
1000	21.6	-5.6

0.29	0.04	0.23	0.02	-10.5	10	3
0.39	0.09	0.32	0.08	-10.5	10	3
0.56	0.14	0.47	0.08	-10.5	10	3
0.73	0.20	0.59	0.12	-10.5	10	3
0.84	0.21	0.70	0.11	-10.5	10	3
0.98	0.24	0.80	0.13	-10.5	10	3
1.04	0.26	0.89	0.15	-10.5	10	3
1.18	0.31	0.96	0.13	-10.5	10	3
1.28	0.35	1.03	0.19	-10.5	10	3
1.39	0.38	1.11	0.22	-10.5	10	3
1.44	0.39	1.20	0.19	-10.5	10	3
1.55	0.46	1.24	0.23	-10.5	10	3
1.59	0.43	1.29	0.23	-10.5	10	3
1.67	0.34	1.35	0.22	-10.5	10	3
1.67	0.42	1.41	0.15	-10.5	10	3
1.87	0.54	1.46	0.25	-10.5	10	3
1.90	0.46	1.51	0.25	-10.5	10	3
1.99	0.60	1.56	0.27	-10.5	10	3
2.14	0.60	1.63	0.29	-10.5	10	3
2.22	0.60	1.66	0.33	-10.5	10	3
2.23	0.61	1.71	0.30	-10.5	10	3

Sample calculation

$$E \text{ (dB } \mu\text{V/m)} = U \text{ (dB } \mu\text{V)} + \text{AF (dB 1/m)} + \text{Corr. (dB)}$$

U = Receiver reading

AF = Antenna factor

Corr. = sum of single correction factors of used cables, switch unit, distance correction, amplifier (if applicable)

distance correction = $-20 * \text{LOG} (d_{Limit} / d_{used})$

Linear interpolation will be used for frequencies in between the values in the table.

Tables show an extract of values.

7.4 ANTENNA R&S HF907 (1 GHZ – 18 GHZ)

Frequency	AF R&S HF907	Corr.
MHz	dB (1/m)	dB
1000	24.4	-19.4
2000	28.5	-17.4
3000	31.0	-16.1
4000	33.1	-14.7
5000	34.4	-13.7
6000	34.7	-12.7
7000	35.6	-11.0

cable loss 1 (relay + cable inside chamber)	cable loss 2 (outside chamber)	cable loss 3 (switch unit, attenuator & pre-amp)	cable loss 4 (to receiver)		
dB	dB	dB	dB		
0.99	0.31	-21.51	0.79		
1.44	0.44	-20.63	1.38		
1.87	0.53	-19.85	1.33		
2.41	0.67	-19.13	1.31		
2.78	0.86	-18.71	1.40		
2.74	0.90	-17.83	1.47		
2.82	0.86	-16.19	1.46		

Frequency	AF R&S HF907	Corr.
MHz	dB (1/m)	dB
3000	31.0	-23.4
4000	33.1	-23.3
5000	34.4	-21.7
6000	34.7	-21.2
7000	35.6	-19.8

cable loss 1 (relay inside chamber)	cable loss 2 (inside chamber)	cable loss 3 (outside chamber)	cable loss 4 (switch unit, attenuator & pre-amp)	cable loss 5 (to receiver)	used for FCC 15.247
dB	dB	dB	dB	dB	
0.47	1.87	0.53	-27.58	1.33	
0.56	2.41	0.67	-28.23	1.31	
0.61	2.78	0.86	-27.35	1.40	
0.58	2.74	0.90	-26.89	1.47	
0.66	2.82	0.86	-25.58	1.46	

Frequency	AF R&S HF907	Corr.
MHz	dB (1/m)	dB
7000	35.6	-57.3
8000	36.3	-56.3
9000	37.1	-55.3
10000	37.5	-56.2
11000	37.5	-55.3
12000	37.6	-53.7
13000	38.2	-53.5
14000	39.9	-56.3
15000	40.9	-54.1
16000	41.3	-54.1
17000	42.8	-54.4
18000	44.2	-54.7

cable loss 1 (relay inside chamber)	cable loss 2 (High Pass)	cable loss 3 (pre-amp)	cable loss 4 (inside chamber)	cable loss 5 (outside chamber)	cable loss 6 (to receiver)
dB	dB	dB	dB	dB	dB
0.56	1.28	-62.72	2.66	0.94	1.46
0.69	0.71	-61.49	2.84	1.00	1.53
0.68	0.65	-60.80	3.06	1.09	1.60
0.70	0.54	-61.91	3.28	1.20	1.67
0.80	0.61	-61.40	3.43	1.27	1.70
0.84	0.42	-59.70	3.53	1.26	1.73
0.83	0.44	-59.81	3.75	1.32	1.83
0.91	0.53	-63.03	3.91	1.40	1.77
0.98	0.54	-61.05	4.02	1.44	1.83
1.23	0.49	-61.51	4.17	1.51	1.85
1.36	0.76	-62.36	4.34	1.53	2.00
1.70	0.53	-62.88	4.41	1.55	1.91

Sample calculation

$$E \text{ (dB } \mu\text{V/m)} = U \text{ (dB } \mu\text{V)} + \text{AF (dB 1/m)} + \text{Corr. (dB)}$$

U = Receiver reading

AF = Antenna factor

Corr. = sum of single correction factors of used cables, switch unit, distance correction, amplifier (if applicable)

Linear interpolation will be used for frequencies in between the values in the table.

Tables show an extract of values.

7.5 ANTENNA EMCO 3160-09 (18 GHZ – 26.5 GHZ)

Frequency MHz	AF EMCO 3160-09 dB (1/m)	Corr. dB
18000	40.2	-23.5
18500	40.2	-23.2
19000	40.2	-22.0
19500	40.3	-21.3
20000	40.3	-20.3
20500	40.3	-19.9
21000	40.3	-19.1
21500	40.3	-19.1
22000	40.3	-18.7
22500	40.4	-19.0
23000	40.4	-19.5
23500	40.4	-19.3
24000	40.4	-19.8
24500	40.4	-19.5
25000	40.4	-19.3
25500	40.5	-20.4
26000	40.5	-21.3
26500	40.5	-21.1

cable loss 1 (inside chamber) dB	cable loss 2 (pre- amp) dB	cable loss 3 (inside chamber) dB	cable loss 4 (switch unit) dB	cable loss 5 (to receiver) dB
0.72	-35.85	6.20	2.81	2.65
0.69	-35.71	6.46	2.76	2.59
0.76	-35.44	6.69	3.15	2.79
0.74	-35.07	7.04	3.11	2.91
0.72	-34.49	7.30	3.07	3.05
0.78	-34.46	7.48	3.12	3.15
0.87	-34.07	7.61	3.20	3.33
0.90	-33.96	7.47	3.28	3.19
0.89	-33.57	7.34	3.35	3.28
0.87	-33.66	7.06	3.75	2.94
0.88	-33.75	6.92	3.77	2.70
0.90	-33.35	6.99	3.52	2.66
0.88	-33.99	6.88	3.88	2.58
0.91	-33.89	7.01	3.93	2.51
0.88	-33.00	6.72	3.96	2.14
0.89	-34.07	6.90	3.66	2.22
0.86	-35.11	7.02	3.69	2.28
0.90	-35.20	7.15	3.91	2.36

Sample calculation

$$E \text{ (dB } \mu\text{V/m)} = U \text{ (dB } \mu\text{V)} + AF \text{ (dB 1/m)} + Corr. \text{ (dB)}$$

U = Receiver reading

AF = Antenna factor

Corr. = sum of single correction factors of used cables, switch unit, distance correction, amplifier (if applicable)

Linear interpolation will be used for frequencies in between the values in the table.

Table shows an extract of values.

7.6 ANTENNA EMCO 3160-10 (26.5 GHZ – 40 GHZ)

Frequency GHz	AF EMCO 3160-10 dB (1/m)	Corr. dB	cable loss 1 (inside chamber) dB	cable loss 2 (outside chamber) dB	cable loss 3 (switch unit) dB	cable loss 4 (to receiver) dB	distance corr. (-20 dB/ decade) dB	d _{Limit} (meas. distance (limit) m	d _{used} (meas. distance (used) m
26.5	43.4	-11.2	4.4				-9.5	3	1.0
27.0	43.4	-11.2	4.4				-9.5	3	1.0
28.0	43.4	-11.1	4.5				-9.5	3	1.0
29.0	43.5	-11.0	4.6				-9.5	3	1.0
30.0	43.5	-10.9	4.7				-9.5	3	1.0
31.0	43.5	-10.8	4.7				-9.5	3	1.0
32.0	43.5	-10.7	4.8				-9.5	3	1.0
33.0	43.6	-10.7	4.9				-9.5	3	1.0
34.0	43.6	-10.6	5.0				-9.5	3	1.0
35.0	43.6	-10.5	5.1				-9.5	3	1.0
36.0	43.6	-10.4	5.1				-9.5	3	1.0
37.0	43.7	-10.3	5.2				-9.5	3	1.0
38.0	43.7	-10.2	5.3				-9.5	3	1.0
39.0	43.7	-10.2	5.4				-9.5	3	1.0
40.0	43.8	-10.1	5.5				-9.5	3	1.0

Sample calculation

$$E \text{ (dB } \mu\text{V/m)} = U \text{ (dB } \mu\text{V)} + \text{AF (dB 1/m)} + \text{Corr. (dB)}$$

U = Receiver reading

AF = Antenna factor

Corr. = sum of single correction factors of used cables, switch unit, distance correction, amplifier (if applicable)

Linear interpolation will be used for frequencies in between the values in the table.

$$\text{distance correction} = -20 * \text{LOG} (d_{\text{Limit}} / d_{\text{used}})$$

Linear interpolation will be used for frequencies in between the values in the table.

Table shows an extract of values.

8 MEASUREMENT UNCERTAINTIES

Test Case	Parameter	Uncertainty
Conducted Emissions at AC mains	Voltage	± 3.4 dB
Radiated Emissions	Field Strength	± 5.5 dB

The measurement uncertainties for all parameters are calculated with an expansion factor (coverage factor) $k = 1.96$. This means, that the true value is in the corresponding interval with a probability of 95 %.

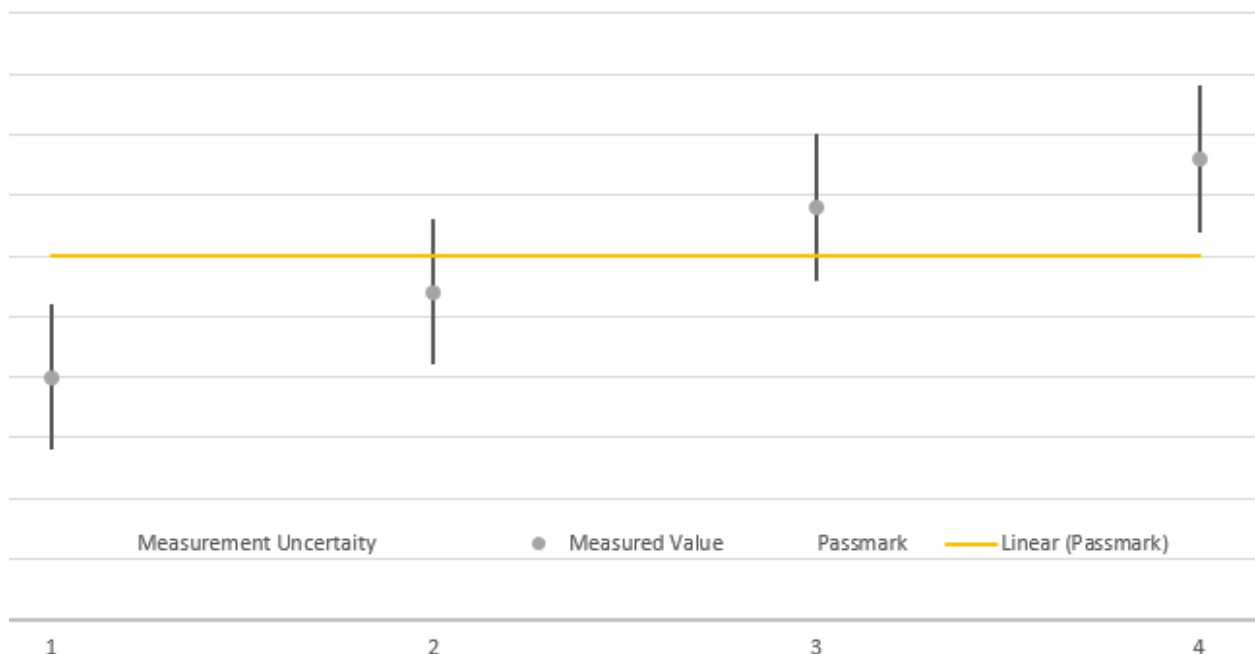

The verdicts in this test report are given according the above diagram:

Case	Measured Value	Uncertainty Range	Verdict
1	below pass mark	below pass mark	Passed
2	below pass mark	within pass mark	Passed
3	above pass mark	within pass mark	Failed
4	above pass mark	above pass mark	Failed

That means, the laboratory applies, as decision rule (see ISO/IEC 17025:2017), the so called shared risk principle.

9 PHOTO REPORT

Please see separate photo report.