



Test Report No.: RF190626W002-1



FCC TEST REPORT (PART 22)



Applicant:	ShadowTrack Technologies, Inc.
Address:	Cypress Bend Office Building, 1001 Ochsner Blvd Suite 425A, Covington, LA. 70433, USA

Manufacturer or Supplier:	Shenzhen Xexun Technology Co.,Ltd
Address:	F/7, Guangrong Building, MeiHua Rd., ShangMei lin,FuTian District, ShenZhen, China
Product:	ShadoWatch
Brand Name:	Shadowtrack
Model Name:	SG-001-18
FCC ID:	2ARH7-SG-001-18
Date of tests:	Jun 27, 2019 ~ Aug 14, 2019

The tests have been carried out according to the requirements of the following standard:

- FCC PART 22, Subpart H
- ANSI/TIA/EIA-603-D
- ANSI/TIA/EIA-603-E
- FCC PART 2
- ANSI C63.26-2015

CONCLUSION: The submitted sample was found to COMPLY with the test requirement

Prepared by Alex Chen Engineer / Mobile Department	Approved by Luke Lu Manager / Mobile Department
 Date: Aug 16, 2019	 Date: Aug 16, 2019

This report is governed by, and incorporates by reference, CPS Conditions of Service as posted at the date of issuance of this report at <http://www.bureauveritas.com/home/about-us/our-business/cps/about-us/terms-conditions> and is intended for your exclusive use. Any copying or replication of this report to or for any other person or entity, or use of our name or trademark, is permitted only with our prior written permission. This report sets forth our findings solely with respect to the test samples identified herein. The results set forth in this report are not indicative or representative of the quality or characteristics of the lot from which a test sample was taken or any similar or identical product unless specifically and expressly noted. Our report includes all of the tests requested by you and the results thereof based upon the information that you provided to us. Measurement uncertainty is only provided upon request for accredited tests. You have 60 days from date of issuance of this report to notify us of any material error or omission caused by our negligence or if you require measurement uncertainty; provided, however, that such notice shall be in writing and shall specifically address the issue you wish to raise. A failure to raise such issue within the prescribed time shall constitute your unqualified acceptance of the completeness of this report, the tests conducted and the correctness of the report contents.



TABLE OF CONTENTS

RELEASE CONTROL RECORD4

1 SUMMARY OF TEST RESULTS.....5

1.1 MEASUREMENT UNCERTAINTY7

1.2 TEST SITE AND INSTRUMENTS8

2 GENERAL INFORMATION9

2.1 GENERAL DESCRIPTION OF EUT9

2.2 CONFIGURATION OF SYSTEM UNDER TEST10

2.3 DESCRIPTION OF SUPPORT UNITS11

2.4 TEST ITEM AND TEST CONFIGURATION.....11

2.5 EUT OPERATING CONDITIONS12

2.6 GENERAL DESCRIPTION OF APPLIED STANDARDS13

3 TEST TYPES AND RESULTS.....14

3.1 OUTPUT POWER MEASUREMENT14

3.1.1 LIMITS OF OUTPUT POWER MEASUREMENT14

3.1.2 TEST PROCEDURES14

3.1.3 TEST SETUP15

3.1.4 TEST RESULTS17

3.2 FREQUENCY STABILITY MEASUREMENT19

3.2.1 LIMITS OF FREQUENCY STABILITY MEASUREMENT19

3.2.2 TEST PROCEDURE19

3.2.3 TEST SETUP19

3.2.4 TEST RESULTS20

3.3 OCCUPIED BANDWIDTH MEASUREMENT20

3.3.1 TEST PROCEDURES20

3.3.2 TEST SETUP20

3.3.3 TEST RESULTS21

3.4 BAND EDGE MEASUREMENT21

3.4.1 LIMITS OF BAND EDGE MEASUREMENT21

3.4.2 TEST SETUP21

3.4.3 TEST PROCEDURES22

3.4.4 TEST RESULTS23

3.5 CONDUCTED SPURIOUS EMISSIONS.....23

3.5.1 LIMITS OF CONDUCTED SPURIOUS EMISSIONS MEASUREMENT23

3.5.2 TEST PROCEDURE23

3.5.3 TEST SETUP23

3.5.4 TEST RESULTS24

3.6 RADIATED EMISSION MEASUREMENT24

3.6.1 LIMITS OF RADIATED EMISSION MEASUREMENT24

3.6.2 TEST PROCEDURES24

3.6.3 DEVIATION FROM TEST STANDARD24

3.6.4 TEST SETUP25



**BUREAU
VERITAS**

Test Report No.: RF190626W002-1

3.6.5	TEST RESULTS	26
3.7	PEAK TO AVERAGE RATIO	34
3.7.1	LIMITS OF PEAK TO AVERAGE RATIO MEASUREMENT	34
3.7.2	TEST SETUP	34
3.7.3	TEST PROCEDURES	34
3.7.4	TEST RESULTS	34
4	PHOTOGRAPHS OF THE TEST CONFIGURATION	35
5	INFORMATION ON THE TESTING LABORATORIES	36
6	APPENDIX A – MODIFICATIONS RECORDERS FOR ENGINEERING CHANGES TO THE EUT BY THE LAB	37



BUREAU
VERITAS

Test Report No.: RF190626W002-1

RELEASE CONTROL RECORD

ISSUE NO.	REASON FOR CHANGE	DATE ISSUED
RF190626W002-1	Original release	Aug 16, 2019



1 SUMMARY OF TEST RESULTS

The EUT has been tested according to the following specifications:

APPLIED STANDARD: FCC Part 22 & Part 2			
STANDARD SECTION	TEST TYPE	RESULT	REMARK
2.1046 22.913 (a)	Effective Radiated Power	PASS	Meet the requirement of limit.
2.1055 22.355	Frequency Stability	PASS	See Note
2.1049 22.917b	Occupied Bandwidth	PASS	See Note
--	Peak to average ratio*	PASS	See Note
22.917	Band Edge Measurements	PASS	See Note
2.1051 22.917	Conducted Spurious Emissions	PASS	See Note
2.1053 22.917	Radiated Spurious Emissions	PASS	Meet the requirement of limit. Minimum passing margin is -14.90dB at 35.290MHz.

Note: These items please refer to the LTE module report I16D00113-RFA_V2 which The FCC ID is UDV-201606, and the LTE module has been certified by ACB,Inc. on 08/17/2016. More detil please refer Statement and certified history as below.

* Refer to KDB 971168 D01 Power Meas License Digital Systems v03r01.

Statement :

The host **SG-001-18** (FCC ID: **2ARH7-SG-001-18**) is a new product with one certified module **SIM7600A**(Module ID: **UDV-201709**; Grant Date: **October,11,2017**). The module **SIM7600A** support WCDMA/DC-HSDPA/LET, manufactured by Shanghai Simcom Ltd, it is a variant product change ID from **SIM7500A**(Module ID: **UDV-201606**; Grant Date: **October,21,2016**).The module **SIM7500A** had Class II Permissive Change to enable LTE band 12 and disable band 17 via software. The module **SIM7500A** first certified by ACB,Inc. on August,17,2016.follow table was the module's certified history:



Test Report No.: RF190626W002-1

CERTIFIED HISTORY		
PROJECT	SIM7500A	
FCC ID	UDV-201606	
GRANT DATA	8/17/2016	
TCB	ACB,Inc.	
SUPPORT LTE BAND	B2,B4,B17	
REPORT NUMBER& REPORT NAME	REPORT NUMBER	REPORT NAME
	I16D00113-EMC.pdf	SIM7500A_FCC_EMCC Report_2016.pdf
	I16D00113-RFA-01_V1.pdf	SIM7500A_FCC_4G RF Test Report_2016.pdf
	I16D00113-RFA_V2.pdf	SIM7500A_FCC_3G RF Test Report_2016.pdf
	I16D00113-SAR.pdf	SIM7500A_FCC_SAR Report_2016.pdf
I16Z41276-GTE01_part222427_LTE_Rev2.pdf	SIM7500A_FCC_part 22&24&27 Test Report_2016.pdf	
PROJECT	SIM7500A C2PC	
FCC ID	UDV-201606	
GRANT DATA	10/21/2016	
TCB	ACB,Inc.	
SUPPORT LTE BAND	B2,B4,B12	
REPORT NUMBER& REPORT NAME	REPORT NUMBER	REPORT NAME
	I16D00213-EMC.pdf	SIM7500A_FCC C2PC_EMCC Report_2016.pdf
	I16D00213-SAR_V1.pdf	SIM7500A_FCC C2PC_SAR Report_2016.pdf
	BL-SZ1690342-501 V02	SIM7500A_FCC C2PC_Test Report_2016.pdf
	I16D00113-EMC.pdf	SIM7500A_FCC_EMCC Report_2016.pdf
	I16D00113-RFA-01_V1.pdf	SIM7500A_FCC_4G RF Test Report_2016.pdf
	I16D00113-RFA_V2.pdf	SIM7500A_FCC_3G RF Test Report_2016.pdf
	I16D00113-SAR.pdf	SIM7500A_FCC_SAR Report_2016.pdf
I16Z41276-GTE01_part222427_LTE_Rev2.pdf	SIM7500A_FCC_part 22&24&27 Test Report_2016.pdf	
PROJECT	SIM7600A(change ID)	
FCC ID	UDV-201709	
GRANT DATA	10/11/2017	
TCB	ACB,Inc.	
SUPPORT LTE BAND	B2,B4,B12	
REPORT NUMBER& REPORT NAME	REPORT NUMBER	REPORT NAME
	I17D00219-SRD05.pdf	SIM7600A_FCC_3G RF Test Report_2017.pdf
	I17D00219-SRD06.pdf	SIM7600A_FCC_4G RF Test Report_2017.pdf
	17D00219-EMC01.pdf	SIM7600A_FCC_EMCC Report_2017.pdf
I17D000219-MPE01 V2 Draft.pdf	SIM7600A_FCC_MPE Report_2017.pdf	

1.1 MEASUREMENT UNCERTAINTY

Where relevant, the following measurement uncertainty levels have been estimated for tests performed on the EUT as specified in CISPR 16-4-2:

MEASUREMENT	UNCERTAINTY
Effective Radiated Power	$\pm 4.48\text{dB}$
Frequency Stability	$\pm 39.27\text{Hz}$
Radiated emissions	$\pm 4.48\text{dB}$
Conducted emissions	$\pm 2\text{ dB}$
Occupied Channel Bandwidth	$\pm 21.7\text{KHz}$
Band Edge Measurements	$\pm 4.48\text{dB}$
Peak to average ratio	$\pm 0.76\text{dB}$

This uncertainty represents an expanded uncertainty expressed at approximately the 95% confidence level using a coverage factor of $k=2$.



1.2 TEST SITE AND INSTRUMENTS

Equipment	Manufacturer	Model No.	Serial No.	Last Cal.	Next Cal.
MXE EMI Receiver	KEYSIGHT	N9038A-544	MY54450026	Feb. 26,19	Feb. 25,20
EXA Signal Analyzer	KEYSIGHT	N9010A-526	MY54510322	Feb. 26,19	Feb. 25,20
Bilog Antenna 1	ETS-LINDGREN	3143B	00161964	Feb. 26,19	Feb. 25,20
Bilog Antenna 2	ETS-LINDGREN	3143B	00161965	Feb. 26,19	Feb. 25,20
Horn Antenna 1	ETS-LINDGREN	3117	00168728	Feb. 26,19	Feb. 25,20
Horn Antenna 2	ETS-LINDGREN	3117	00168692	Nov. 30, 18	Nov. 29, 19
Horn Antenna (18GHz-40GHz)	N/A	QWH-SL-18-40 -K-SG/QMS-00 361	15433	Nov. 21, 18	Nov. 20, 19
Radio Communication Analyzer	ANRITSU	MT8820C	6201465426	Feb. 26,19	Feb. 25,20
Signal Pre-Amplifier	EMSI	EMC 9135	980249	Jun. 24,19	Jun. 23,20
Signal Pre-Amplifier	EMSI	EMC 012645B	980257	Jun. 24,19	Jun. 23,20
Signal Pre-Amplifier	EMSI	EMC 184045B	980259	Jun. 24,19	Jun. 23,20
3m Semi-anechoic Chamber	ETS-LINDGREN	9m*6m*6m	Euroshieldpn- CT0001143-1216	Feb. 26,19	Feb. 25,20
Test Software	E3	V 9.160323	N/A	N/A	N/A
Test Software	ADT	ADT_Radiated _V7.6.15.9.2	N/A	N/A	N/A
10dB Attenuator	JFW/USA	50HF-010-SM A	1505	Jun. 24,19	Jun. 23,20
Power Meter	Anritsu	ML2495A	1506002	Feb. 26,19	Feb. 25,20
Power Sensor	Anritsu	MA2411B	1339352	Feb. 26,19	Feb. 25,20
Humid & Temp Programmable Tester	Juyi	ITH-120-45-CP -AR	IAA1504-001	Jun. 24,19	Jun. 23,20
MXG Analog Microvave Signal Generator	KEYSIGHT	N5183A	MY50143024	Feb. 26,19	Feb. 25,20

NOTE: 1. The calibration interval of the above test instruments is 12 months or 24 months and the calibrations are traceable to CEPREI/CHINA, GRGT/CHINA and NIM/CHINA.

2. The test was performed in 3m Semi-anechoic Chamber and RF Oven Room.
3. The horn antenna is used only for the measurement of emission frequency above 1GHz if tested.
4. The FCC Site Registration No. is 525120; The Designation No. is CN1171.



2 GENERAL INFORMATION

2.1 GENERAL DESCRIPTION OF EUT

EUT	ShadoWatch	
BRAND NAME	Shadowtrack	
MODEL NAME	SG-001-18	
POWER SUPPLY	5Vdc (adapter or host equipment) 3.7Vdc (Li-ion, battery)	
MODULATION TYPE	WCDMA	BPSK, QPSK
FREQUENCY RANGE	WCDMA	826.4MHz ~ 846.6MHz
MAX. ERP POWER	WCDMA	254mW
EMISSION DESIGNATOR	WCDMA	4M15F9W
ANTENNA TYPE	FPC Antenna	
HW VERSION	4G_MT2503MB_V1.1	
SW VERSION	A03190531V01	
I/O PORTS	Refer to user's manual	
DATA CABLE	Refer to note as below	

NOTE:

1. For a more detailed features description, please refer to the manufacturer's specifications or the user's manual.
2. For the test results, the EUT had been tested with all conditions. But only the worst case was shown in test report.

3. List of Accessories:

ACCESSORIES	BRAND	MODEL	Manufacturer	SPECIFICATION
LCD Panel	SHENZHEN LIJING	LD-1.54TFT-16PIN	LIJING ELECTRONICS CO.,LTD	-
CPU	MTK	MT2503	MediaTek.Inc	-
WLAN Module	MTK	MT5931	MediaTek.Inc	-
4G Module	SIMCOM	SIM7600A	SIMCOM	-
Battery	SHENZHEN HUAYOU	603048	SHENZHEN HUAYOU POLYMER LI-ION BATTERY CO.,LTD	3.7Vdc, 800 mAh
Wireless Charger	SHADOWTRACK	ShadoWatch WLC00119	Xexun	I/P: 5V, 2 A, O/P: 5W Max



2.2 CONFIGURATION OF SYSTEM UNDER TEST

FOR RADIATION EMISSION

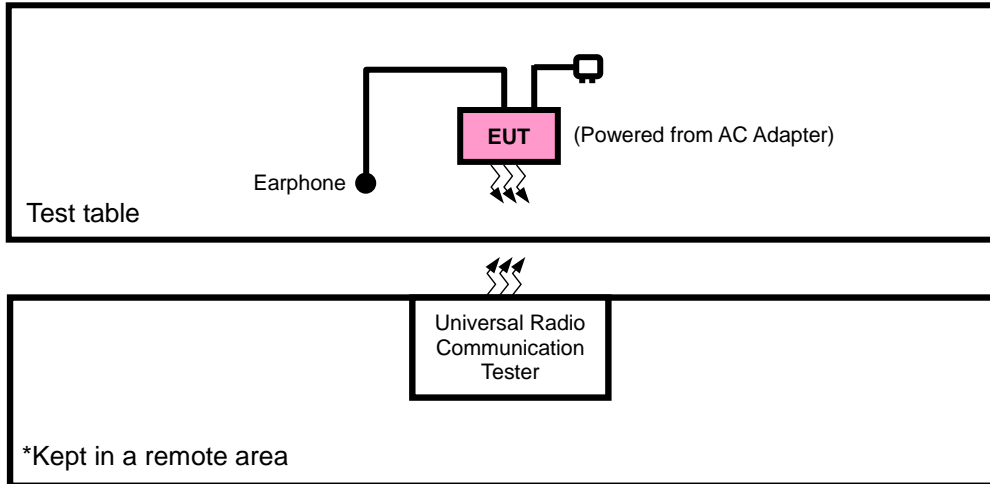

FOR CONDUCTED & E.R.P. TEST

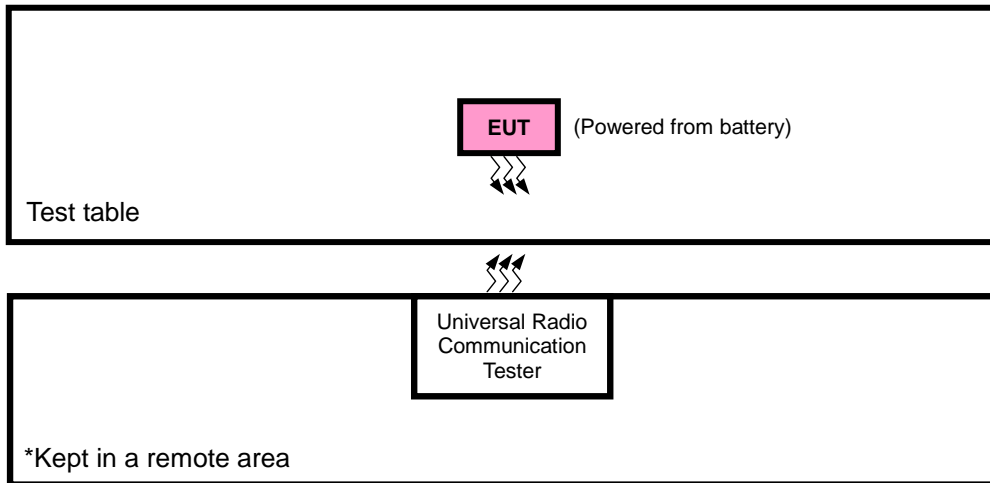



2.3 DESCRIPTION OF SUPPORT UNITS

The EUT has been tested as an independent unit together with other necessary accessories or support units. The following support units or accessories were used to form a representative test configuration during the tests.

NO.	PRODUCT	BRAND	MODEL NO.	SERIAL NO.	FCC ID
1	DC source	LONG WEI	PS-6403D	010934269	N/A
2	PC	HP	A6608CN	3CR83825X3	N/A

NO.	SIGNAL CABLE DESCRIPTION OF THE ABOVE SUPPORT UNITS
1	DC Line: Unshielded, Detachable 1.0m
2	AC Line: Unshielded, Detachable 1.5m

NOTE:

1. All power cords of the above support units are non shielded (1.8m).

2.4 TEST ITEM AND TEST CONFIGURATION

Pre-Scan has been conducted to determine the worst-case mode from all possible combinations between available modulations, data rates, XYZ axis and antenna ports. The worst case in ERP and radiated emission was found when positioned on X-plane for WCDMA/LTE. Following channel(s) was (were) selected for the final test as listed below:

EUT CONFIGURE MODE	DESCRIPTION
A	EUT + Adapter with WCDMA
B	EUT + Battery with WCDMA



WCDMA MODE

EUT CONFIGURE MODE	TEST ITEM	AVAILABLE CHANNEL	TESTED CHANNEL	MODE
B	ERP	4132 to 4233	4132, 4182, 4233	WCDMA
A	RADIATED EMISSION	4132 to 4233	4132, 4182, 4233	WCDMA

TEST ITEM	ENVIRONMENTAL CONDITIONS	INPUT POWER	TESTED BY
ERP	23deg. C, 70%RH	3.7Vdc from Battery	Star Le
RADIATED EMISSION	23deg. C, 70%RH	5Vdc from Adapter	Star Le

2.5 EUT OPERATING CONDITIONS

The EUT makes a call to the communication simulator. The communication simulator station system controlled a EUT to export maximum output power under transmission mode and specific channel frequency



Test Report No.: RF190626W002-1

2.6 GENERAL DESCRIPTION OF APPLIED STANDARDS

The EUT is a RF product. According to the specifications of the manufacturer, it must comply with the requirements of the following standards:

FCC 47 CFR Part 2

FCC 47 CFR Part 22

KDB 971168 D01 Power Meas License Digital Systems v03r01

ANSI/TIA/EIA-603-D

ANSI/TIA/EIA-603-E

ANSI C63.26-2015

NOTE: All test items have been performed and recorded as per the above standards.

3 TEST TYPES AND RESULTS

3.1 OUTPUT POWER MEASUREMENT

3.1.1 LIMITS OF OUTPUT POWER MEASUREMENT

Mobile / Portable station are limited to 7 watts e.r.p.

3.1.2 TEST PROCEDURES

EIRP / ERP MEASUREMENT:

- a. All measurements were done at low, middle and high operational frequency range. RBW and VBW is 5MHz for WCDMA mode and 10MHz for LTE mode.
- b. Substitution method is used for E.I.R.P measurement. In the semi-anechoic chamber, EUT placed on the 0.8m height of Turn Table, rotated the table around 360 degrees to search the maximum radiation power and receiver antenna shall be rotated vertical and horizontal polarization and moved height from 1m to 4m to find the maximum polar radiated power. The “Read Value” is the spectrum reading the maximum power value.
- c. The substitution horn antenna is substituted for EUT at the same position and signals generator export the CW signal to the substitution antenna via a tx cable. Rotated the Turn Table and moved receiving antenna to find the maximum radiation power. Adjust output power level of S.G to get a Value of spectrum reading equal to “Read Value” of step b. Record the power level of S.G
- d. $EIRP = \text{Output power level of S.G} - \text{TX cable loss} + \text{Antenna gain of substitution horn}$.
E.R.P power can be calculated form E.I.R.P power by subtracting the gain of dipole,
 $E.R.P \text{ power} = E.I.P.R \text{ power} - 2.15\text{dBi}$.

CONDUCTED POWER MEASUREMENT:

The EUT was set up for the maximum power with WCDMA link data modulation and link up with simulator. Set the EUT to transmit under low, middle and high channel and record the power level shown on simulator.



3.1.3 TEST SETUP

EIRP / ERP Measurement:

<Radiated Emission below or equal 1 GHz>

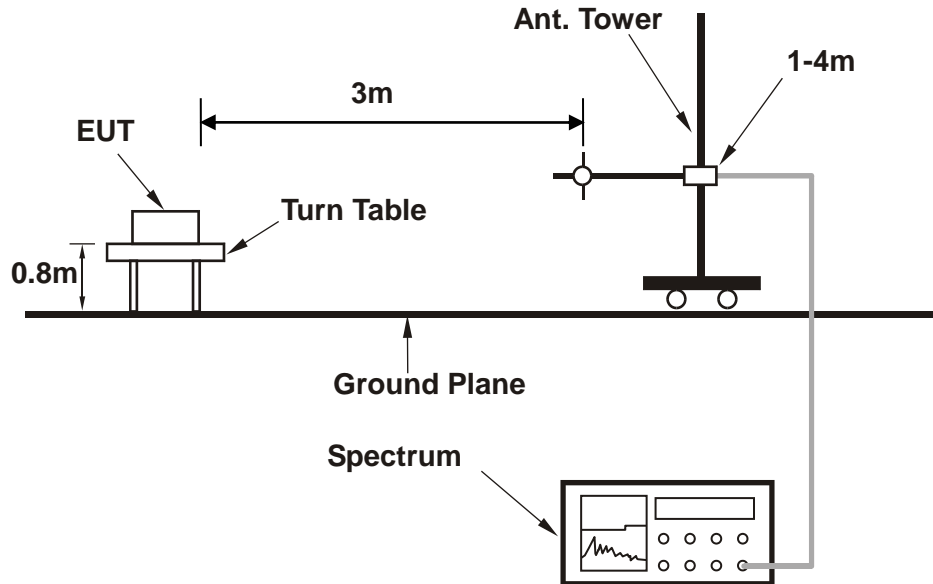

<Frequency Range above 1GHz>

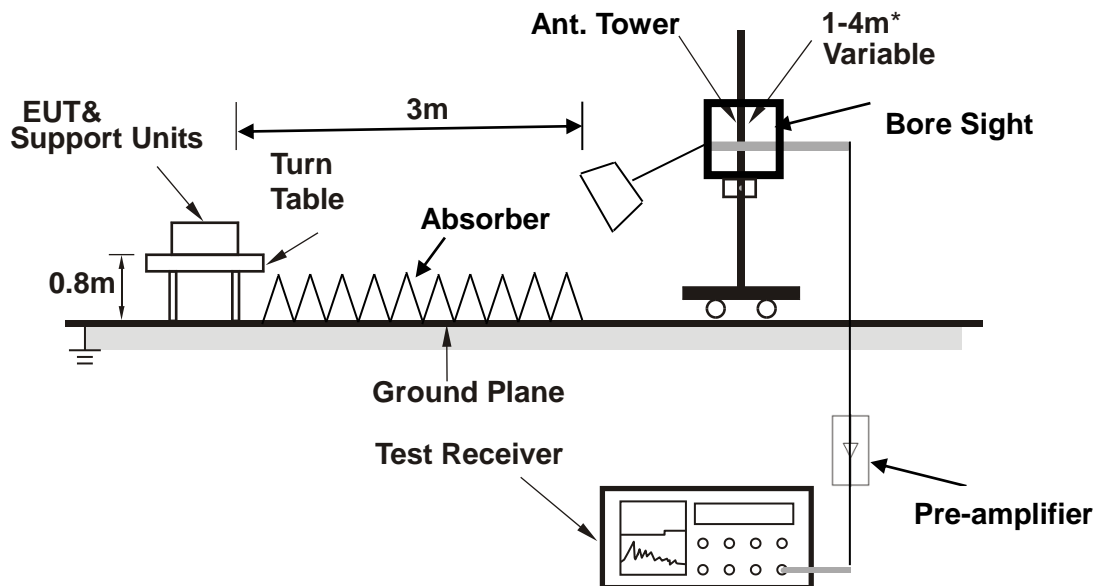

Note: Above 1G is a directional antenna

Depends on the EUT height and the antenna 3dB bandwidth both, refer to section 7.3 of CISPR 16-2-3.

For the actual test configuration, please refer to the attached file (Test Setup Photo).



**BUREAU
VERITAS**

Test Report No.: RF190626W002-1

CONDUCTED POWER MEASUREMENT:

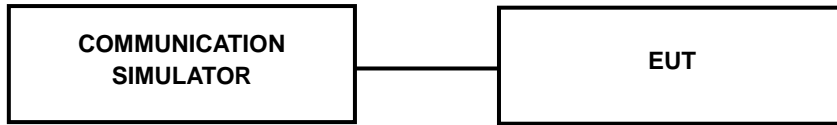



3.1.4 TEST RESULTS

CONDUCTED OUTPUT POWER (dBm)

Base on verify the Conducted Power is the same with module test report (I16D00113-RFA-V2) by lab, the test results please refer the module Report No.: I16D00113-RFA-V2, and the pre-scan data as below.

LTE WCDMA V

Band	WCDMA V		
Channel	4132	4182	4233
Frequency (MHz)	826.4	836.4	846.6
RMC 12.2K	24.55	24.58	24.52
HSPA			
HSDPA Subtest-1	23.64	23.67	23.61
HSDPA Subtest-2	23.56	23.59	23.53
HSDPA Subtest-3	23.00	23.03	22.97
HSDPA Subtest-4	22.93	22.96	22.90
HSUPA Subtest-1	23.55	23.58	23.52
HSUPA Subtest-2	21.51	21.54	21.48
HSUPA Subtest-3	22.59	22.62	22.56
HSUPA Subtest-4	21.55	21.58	21.52
HSUPA Subtest-5	23.44	23.47	23.41



BUREAU
VERITAS

Test Report No.: RF190626W002-1

ERP POWER (dBm)

WCDMA V

Channel	Frequency (MHz)	SPA LVL (dBm)	Correction Factor(dB)	ERP(dBm)	ERP(mW)	Polarization (H/V)
4132	826.4	-7.36	33.56	24.05	254.04	H
4182	836.4	-7.82	33.63	23.66	232.22	H
4233	846.6	-8.35	33.57	23.07	202.67	H
4132	826.4	-13.35	34.24	18.74	74.75	V
4182	836.4	-13.96	34.59	18.48	70.40	V
4233	846.6	-14.99	34.62	17.48	56.01	V

REMARKS: 1. ERP Output Power (dBm) = SPA LVL (dBm) + Correction Factor (dB) -2.15(dB).
2. Correction factor (dB) = Free Space Loss + Antenna Factor + Cable Loss

3.2 FREQUENCY STABILITY MEASUREMENT

3.2.1 LIMITS OF FREQUENCY STABILITY MEASUREMENT

1.5 ppm is for base and fixed station. 2.5 ppm is for mobile station.

3.2.2 TEST PROCEDURE

- Device is placed at the oven room. The oven room could control the temperatures and humidity. Power warm up is at least 15 min and power applied should perform before recording frequency error.
- EUT is connected the external power supply to control the DC input power. The test voltage range is from minimum to maximum working voltage. Each step shall be record the frequency error rate.
- The temperature range step is 10 degrees in this test items. All temperature levels shall be hold the $\pm 0.5^{\circ}\text{C}$ during the measurement testing. The each temperature step shall be at least 0.5 hours, consider the EUT could be test under the stability condition.

NOTE: The frequency error was recorded frequency error from the communication simulator.

3.2.3 TEST SETUP

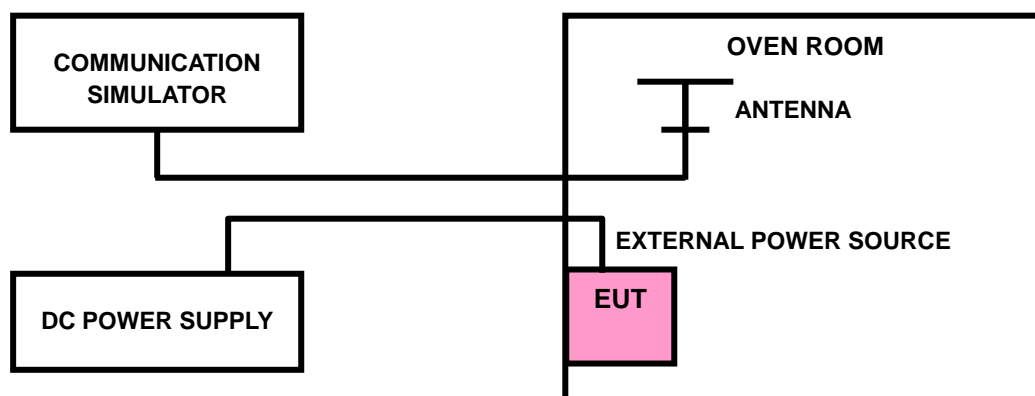



3.2.4 TEST RESULTS

The test results was recorded in Report No.: I16D00113-RFA-V2.

3.3 OCCUPIED BANDWIDTH MEASUREMENT

3.3.1 TEST PROCEDURES

The EUT makes a call to the communication simulator. All measurements were done at low, middle and high operational frequency range. The communication simulator station system controlled a EUT to export maximum output power under transmission mode and specific channel frequency. Use OBW measurement function of Spectrum analyzer to measure 99 % occupied bandwidth.

3.3.2 TEST SETUP

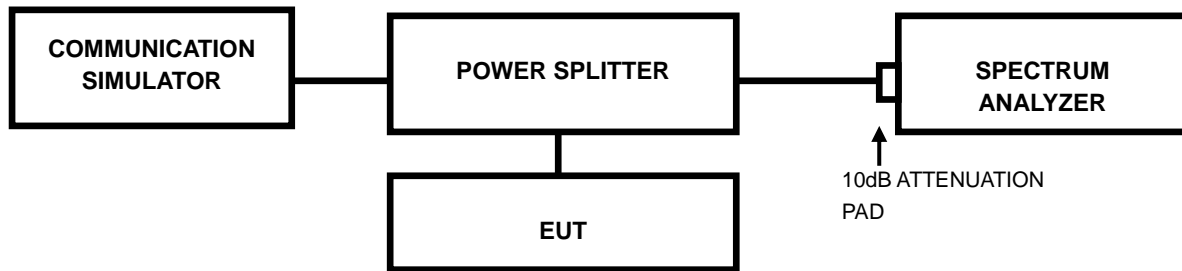

3.3.3 TEST RESULTS

The test results was recorded in Report No.: I16D00113-RFA_V2.

3.4 BAND EDGE MEASUREMENT

3.4.1 LIMITS OF BAND EDGE MEASUREMENT

Power of any emission outside of the authorized operating frequency ranges must be attenuated below the transmitting power (P) by a factor of at least $43 + 10 \log(P)$ dB. In the 1 MHz bands immediately outside and adjacent to the frequency block a resolution bandwidth of at least one percent of the emission bandwidth of the fundamental emission of the transmitter may be employed.

3.4.2 TEST SETUP

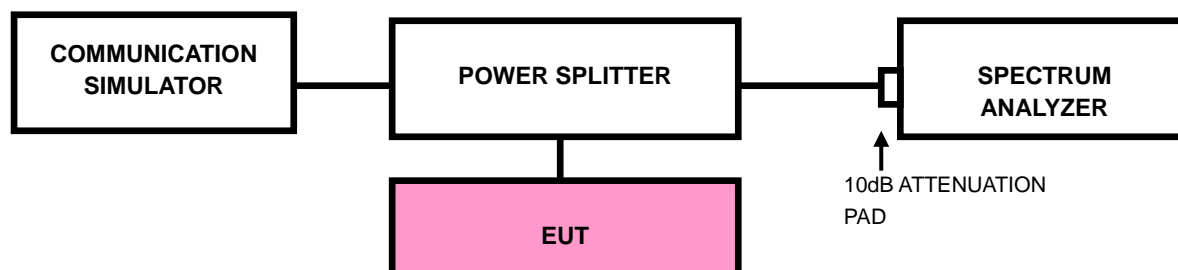



**BUREAU
VERITAS**

Test Report No.: RF190626W002-1

3.4.3 TEST PROCEDURES

- a. All measurements were done at low and high operational frequency range.
- b. The center frequency of spectrum is the band edge frequency and span is 10MHz. RBW of the spectrum is 100kHz and VBW of the spectrum is 300kHz (WCDMA).
- c. Record the max trace plot into the test report.

3.4.4 TEST RESULTS

The test results was recorded in Report No.: I16D00113-RFA_V2.

3.5 CONDUCTED SPURIOUS EMISSIONS

3.5.1 LIMITS OF CONDUCTED SPURIOUS EMISSIONS MEASUREMENT

The power of any emission outside of the authorized operating frequency ranges must be attenuated below the transmitting power (P) by a factor of at least $43 + 10 \log(P)$ dB. The emission limit equal to -13dBm .

3.5.2 TEST PROCEDURE

- a. The EUT makes a phone call to the communication simulator. All measurements were done at low, middle and high operational frequency range.
- b. Measuring frequency range is from 9 kHz to 9GHz. 10dB attenuation pad is connected with spectrum. RBW=1MHz and VBW=3MHz is used for conducted emission measurement.

3.5.3 TEST SETUP

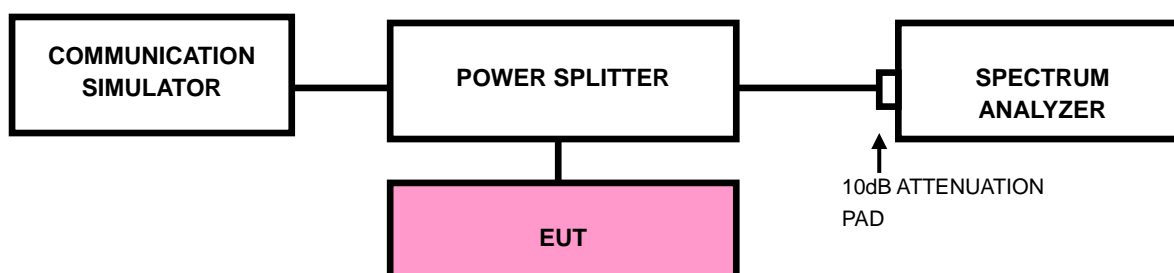



3.5.4 TEST RESULTS

The test results was recorded in Report No.: I16D00113-RFA_V2.

3.6 RADIATED EMISSION MEASUREMENT

3.6.1 LIMITS OF RADIATED EMISSION MEASUREMENT

The power of any emission outside of the authorized operating frequency ranges must be attenuated below the transmitting power (P) by a factor of at least $43 + 10 \log(P)$ dB. The emission limit equal to -13dBm .

3.6.2 TEST PROCEDURES

- a. Substitution method is used for E.I.R.P measurement. In the semi-anechoic chamber, EUT placed on the 0.8m height of Turn Table, rotated the table around 360 degrees to search the maximum radiation power and receiver antenna shall be rotated vertical and horizontal polarization and moved height from 1m to 4m to find the maximum polar radiated power. The “Read Value” is the spectrum reading the maximum power value.
- b. The substitution horn antenna is substituted for EUT at the same position and signals generator export the CW signal to the substitution antenna via a TX cable. Rotated the Turn Table and moved receiving antenna to find the maximum radiation power. Adjust output power level of S.G to get a Value of spectrum reading equal to “Read Value” of step a. Record the power level of S.G
- c. $\text{EIRP} = \text{Output power level of S.G} - \text{TX cable loss} + \text{Antenna gain of substitution horn}$.
- d. E.R.P power can be calculated form E.I.R.P power by subtracting the gain of dipole,
 $\text{E.R.P power} = \text{E.I.P.R power} - 2.15\text{dBi}$.

NOTE: The resolution bandwidth and video bandwidth of test receiver/spectrum analyzer is 1MHz/3MHz.

3.6.3 DEVIATION FROM TEST STANDARD

No deviation



3.6.4 TEST SETUP

< Frequency Range 30MHz~1GHz >

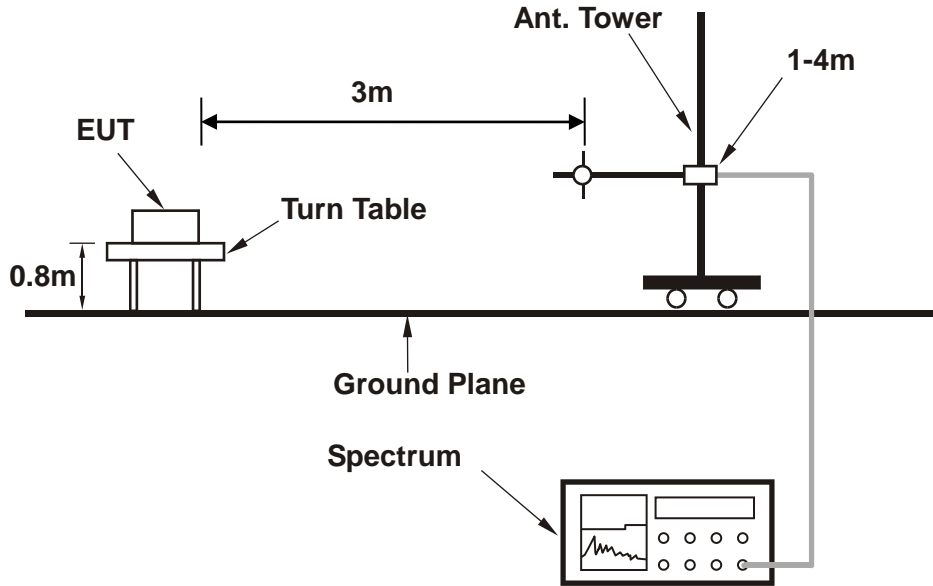

<Frequency Range above 1GHz>

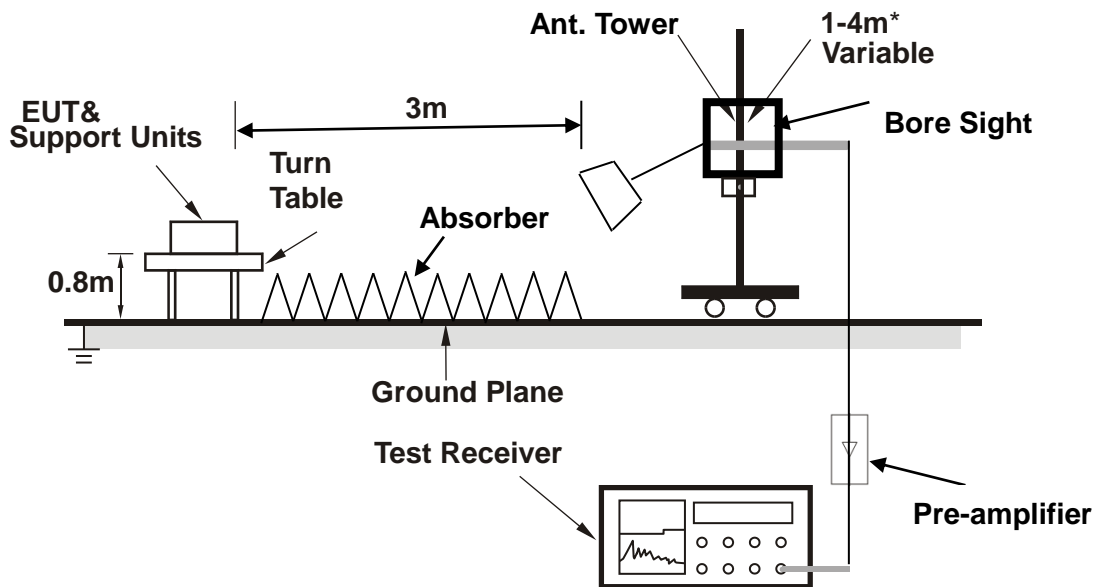

Note: Above 1G is a directional antenna

Depends on the EUT height and the antenna 3dB bandwidth both, refer to section 7.3 of CISPR 16-2-3.

For the actual test configuration, please refer to the attached file (Test Setup Photo).



3.6.5 TEST RESULTS

BELOW 1GHz WORST-CASE DATA

30 MHz – 1GHz data:

WCDMA Band V

MODE	TX channel 4182	FREQUENCY RANGE	Below 1000MHz
ENVIRONMENTAL CONDITIONS	23deg. C, 70%RH	INPUT POWER	DC 5V from adapter
TESTED BY	Star Le		
ANTENNA POLARITY & TEST DISTANCE: HORIZONTAL AT 3 M			

	Freq	Level	Read Level	Limit Line	Over Limit	Factor	Remark	Pol/Phase	
	MHz	dBm/m	dBm	dBm/m	dB	dB/m			
1	PP	35.290	-27.90	-42.15	-13.00	-14.90	14.25	Peak	Horizontal
2		89.670	-36.77	-45.26	-13.00	-23.77	8.49	Peak	Horizontal
3		125.340	-38.03	-46.69	-13.00	-25.03	8.66	Peak	Horizontal
4		205.310	-38.55	-49.58	-13.00	-25.55	11.03	Peak	Horizontal
5		258.740	-39.19	-52.38	-13.00	-26.19	13.19	Peak	Horizontal
6		411.270	-38.04	-55.39	-13.00	-25.04	17.35	Peak	Horizontal

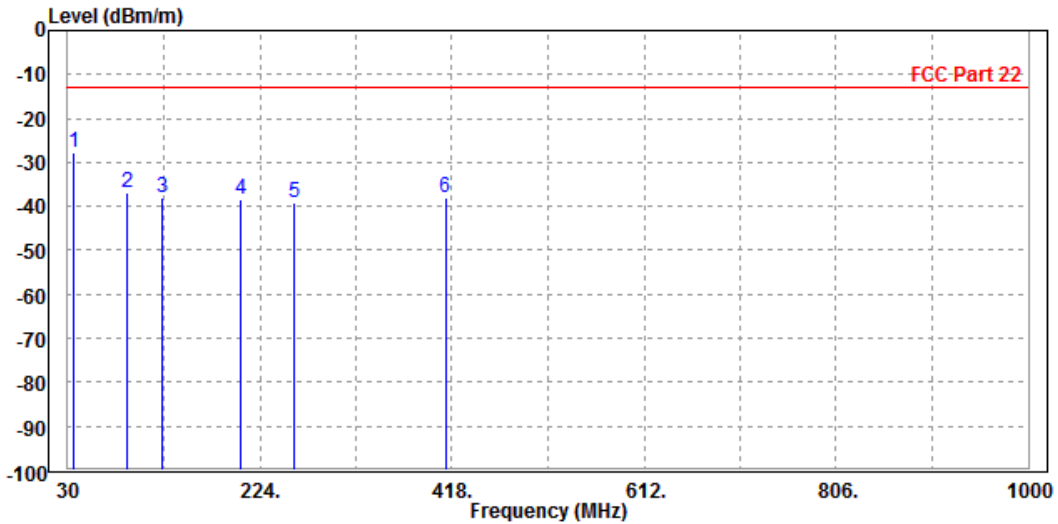



**BUREAU
VERITAS**

Test Report No.: RF190626W002-1

MODE	TX channel 4182	FREQUENCY RANGE	Below 1000MHz
ENVIRONMENTAL CONDITIONS	23deg. C, 70%RH	INPUT POWER	DC 5V from adapter
TESTED BY	Star Le		
ANTENNA POLARITY & TEST DISTANCE: VERTICAL AT 3 M			

	Freq	Level	Read Level	Limit Line	Over Limit	Factor	Remark	Pol/Phase
	MHz	dBm/m	dBm	dBm/m	dB	dB/m		
1	PP	42.360	-33.43	-44.25	-13.00	-20.43	10.82 Peak	Vertical
2		56.320	-38.26	-45.28	-13.00	-25.26	7.02 Peak	Vertical
3		105.240	-42.63	-52.14	-13.00	-29.63	9.51 Peak	Vertical
4		235.210	-42.77	-55.26	-13.00	-29.77	12.49 Peak	Vertical
5		269.890	-44.85	-58.45	-13.00	-31.85	13.60 Peak	Vertical
6		421.360	-39.15	-56.75	-13.00	-26.15	17.60 Peak	Vertical

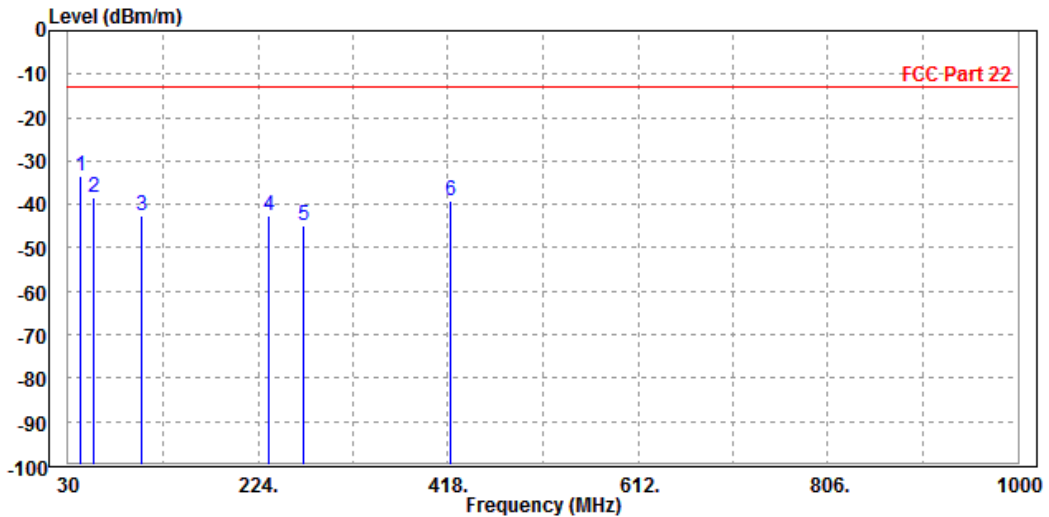



**BUREAU
VERITAS**

Test Report No.: RF190626W002-1

ABOVE 1GHz DATA

Note: For higher frequency, the emission is too low to be detected.

WCDMA Band V:

CH 4132:

MODE	TX channel 4132	FREQUENCY RANGE	Above 1000MHz
ENVIRONMENTAL CONDITIONS	23deg. C, 70%RH	INPUT POWER	DC 5V from adapter
TESTED BY	Star Le		
ANTENNA POLARITY & TEST DISTANCE: HORIZONTAL AT 3 M			

	Freq	Level	Read Level	Limit Line	Over Limit	Factor	Remark	Pol/Phase
	MHz	dBm/m	dBm	dBm/m	dB	dB/m		
1	PP 1648.000	-54.21	-49.24	-13.00	-41.21	-4.97	Peak	Horizontal
2	2480.000	-54.54	-52.89	-13.00	-41.54	-1.65	Peak	Horizontal

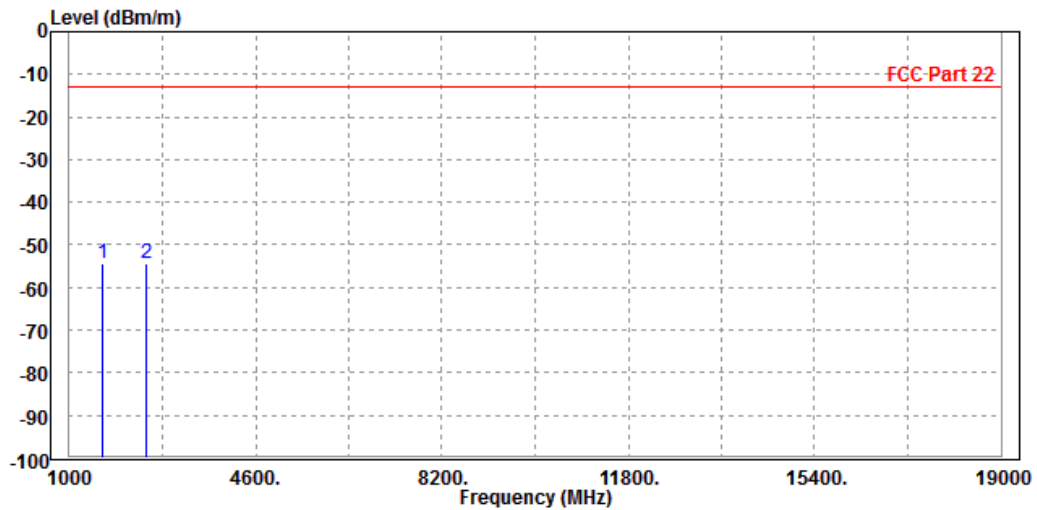



**BUREAU
VERITAS**

Test Report No.: RF190626W002-1

MODE	TX channel 4132	FREQUENCY RANGE	Above 1000MHz
ENVIRONMENTAL CONDITIONS	23deg. C, 70%RH	INPUT POWER	DC 5V from adapter
TESTED BY	Star Le		
ANTENNA POLARITY & TEST DISTANCE: VERTICAL AT 3 M			

	Freq	Level	Read Level	Limit Line	Over Limit	Factor	Remark	Pol/Phase
	MHz	dBm/m	dBm	dBm/m	dB	dB/m		
1	1648.000	-53.84	-50.29	-13.00	-40.84	-3.55	Peak	Vertical
2	PP 2480.000	-52.48	-52.31	-13.00	-39.48	-0.17	Peak	Vertical

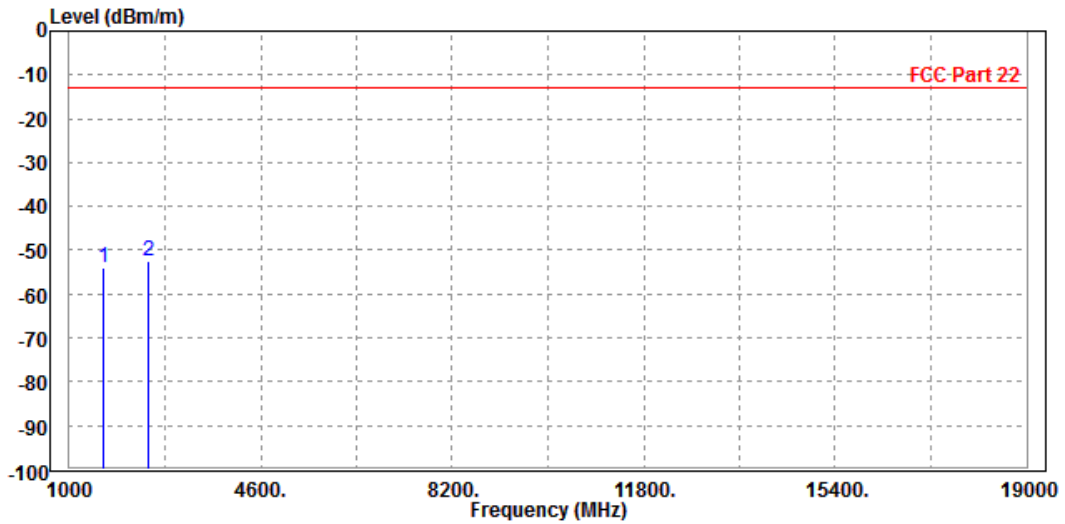



**BUREAU
VERITAS**

Test Report No.: RF190626W002-1

CH 4182:

MODE	TX channel 4182	FREQUENCY RANGE	Above 1000MHz
ENVIRONMENTAL CONDITIONS	23deg. C, 70%RH	INPUT POWER	DC 5V from adapter
TESTED BY	Star Le		
ANTENNA POLARITY & TEST DISTANCE: HORIZONTAL AT 3 M			

	Freq	Level	Read Level	Limit Line	Over Limit	Factor	Remark	Pol/Phase
	MHz	dBm/m	dBm	dBm/m	dB	dB/m		
1	PP 1666.000	-50.45	-45.63	-13.00	-37.45	-4.82	Peak	Horizontal
2	2512.000	-51.80	-50.21	-13.00	-38.80	-1.59	Peak	Horizontal

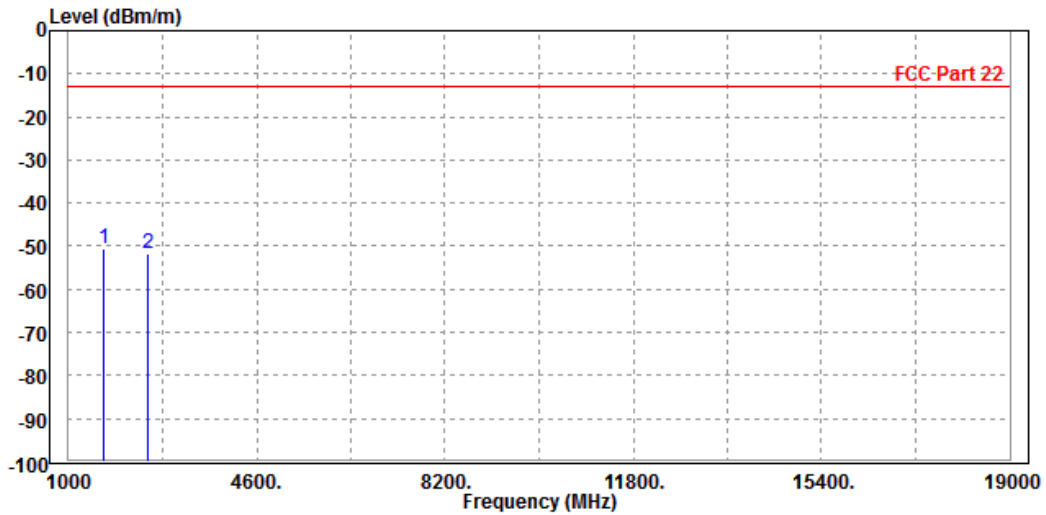



**BUREAU
VERITAS**

Test Report No.: RF190626W002-1

MODE	TX channel 4182	FREQUENCY RANGE	Above 1000MHz
ENVIRONMENTAL CONDITIONS	23deg. C, 70%RH	INPUT POWER	DC 5V from adapter
TESTED BY	Star Le		
ANTENNA POLARITY & TEST DISTANCE: VERTICAL AT 3 M			

	Freq	Level	Read Level	Limit Line	Over Limit	Factor	Remark	Pol/Phase
	MHz	dBm/m	dBm	dBm/m	dB	dB/m		
1	PP 1666.000	-52.07	-48.69	-13.00	-39.07	-3.38	Peak	Vertical
2	2512.000	-52.57	-52.45	-13.00	-39.57	-0.12	Peak	Vertical

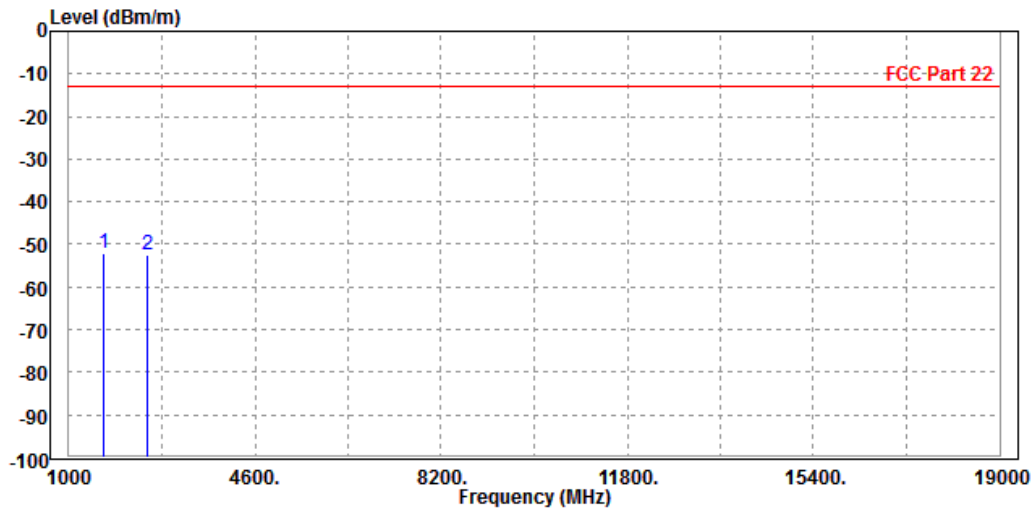



**BUREAU
VERITAS**

Test Report No.: RF190626W002-1

CH 4233:

MODE	TX channel 4233	FREQUENCY RANGE	Above 1000MHz
ENVIRONMENTAL CONDITIONS	23deg. C, 70%RH	INPUT POWER	DC 5V from adapter
TESTED BY	Star Le		
ANTENNA POLARITY & TEST DISTANCE: HORIZONTAL AT 3 M			

	Freq	Level	Read Level	Limit Line	Over Limit	Factor	Remark	Pol/Phase
	MHz	dBm/m	dBm	dBm/m	dB	dB/m		
1	1702.000	-54.78	-50.26	-13.00	-41.78	-4.52	Peak	Horizontal
2 PP	2548.000	-54.62	-53.17	-13.00	-41.62	-1.45	Peak	Horizontal

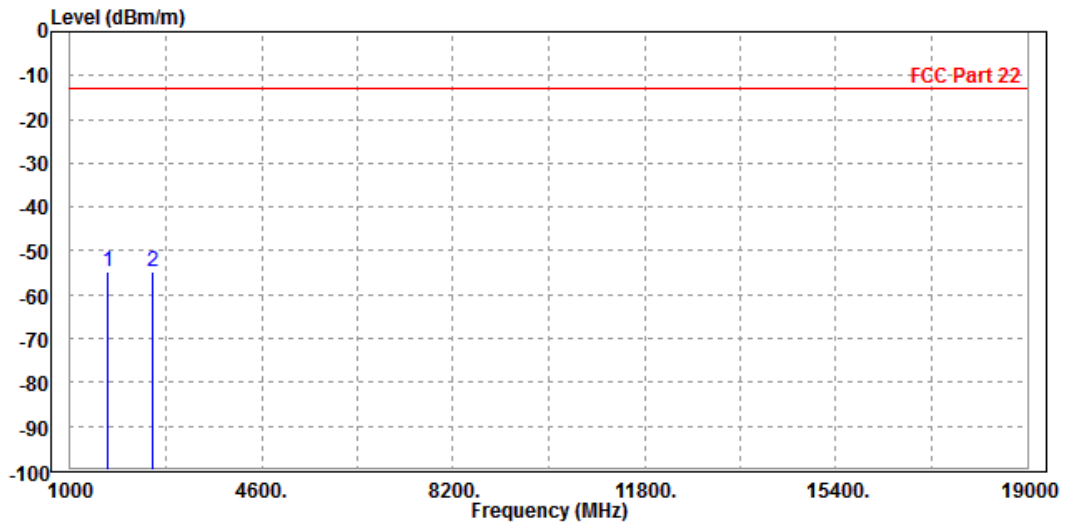



**BUREAU
VERITAS**

Test Report No.: RF190626W002-1

MODE	TX channel 4233	FREQUENCY RANGE	Above 1000MHz
ENVIRONMENTAL CONDITIONS	23deg. C, 70%RH	INPUT POWER	DC 5V from adapter
TESTED BY	Star Le		
ANTENNA POLARITY & TEST DISTANCE: VERTICAL AT 3 M			

	Freq	Level	Read Level	Limit Line	Over Limit	Factor	Remark	Pol/Phase
	MHz	dBm/m	dBm	dBm/m	dB	dB/m		
1	1702.000	-53.17	-50.12	-13.00	-40.17	-3.05	Peak	Vertical
2	PP 2548.000	-52.65	-52.68	-13.00	-39.65	0.03	Peak	Vertical

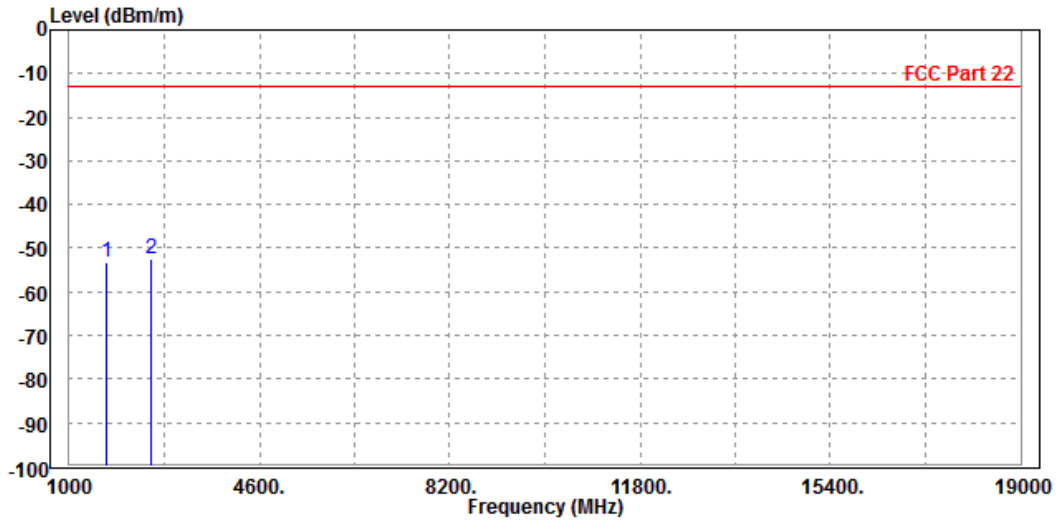

3.7 PEAK TO AVERAGE RATIO

3.7.1 LIMITS OF PEAK TO AVERAGE RATIO MEASUREMENT

In measuring transmissions in this band using an average power technique, the peak to-average ratio (PAR) of the transmission may not exceed 13 dB

3.7.2 TEST SETUP

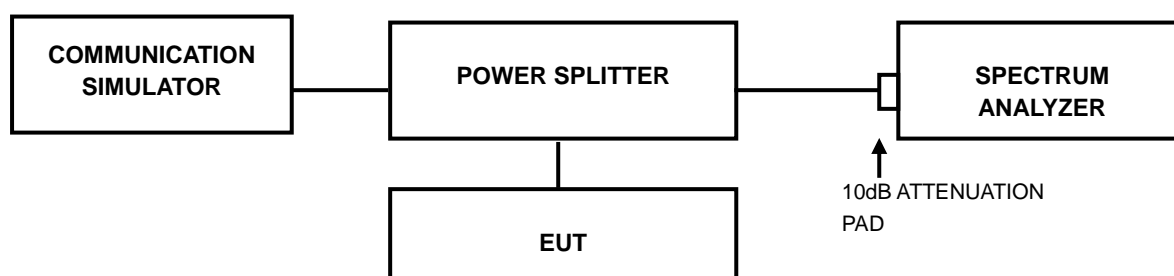

3.7.3 TEST PROCEDURES

1. Set resolution/measurement bandwidth \geq signal's occupied bandwidth;
2. Set the number of counts to a value that stabilizes the measured CCDF curve;
3. Record the maximum PAPR level associated with a probability of 0.1%.

3.7.4 TEST RESULTS

The test results was recorded in Report No.: I16D00113-RFA.



BUREAU
VERITAS

Test Report No.: RF190626W002-1

4 PHOTOGRAPHS OF THE TEST CONFIGURATION

Please refer to the attached file (Test Setup Photo).



Test Report No.: RF190626W002-1

5 INFORMATION ON THE TESTING LABORATORIES

We, BV 7LAYERS COMMUNICATIONS TECHNOLOGY (SHENZHEN) CO. LTD., were founded in 2015 to provide our best service in EMC, Radio, Telecom and Safety consultation. Our laboratories are accredited and approved according to ISO/IEC 17025.

If you have any comments, please feel free to contact us at the following:

Shenzhen EMC/RF Lab:

Tel: +86-755-88696566

Fax: +86-755-88696577

Email: customerservice.dg@cn.bureauveritas.com

Web Site: www.adt.com.tw

The address and road map of all our labs can be found in our web site also.



**BUREAU
VERITAS**

Test Report No.: RF190626W002-1

6 APPENDIX A – MODIFICATIONS RECORDERS FOR ENGINEERING CHANGES TO THE EUT BY THE LAB

No any modifications are made to the EUT by the lab during the test.

---END---