

Product specification

Quick Reference Date

	Antenna module on the system board	
Frequenc Range	2400 ~ 2500GHz	
Ant. Port Input Pwr. (dBm)	0 (Typ. BT class 2 output power)	
Tot. Rad. Pwr. (dBm)	-1.2 (Input pwr – loss pwr)	
Peak EIRP(dBm)	0	
Directivity (dB)	1 (all direction antenna)	
Efficiency (%)	1.0%	
Gain (dBi)	-0.12	
Maximum Power (dBm)	0 (XY-plane)	
Minimum Power (dBm)	0(XY-plane)	
Avg. Power (dBm)	0(XY-plane)	
Input Impedence(ohm)	50	
Polarization Type	V ertical & Horizontal	
V . S . W . R	< 6	

All the technical data and information contained herein are subject to change without prior notice

Antenna Layout & module on the system board

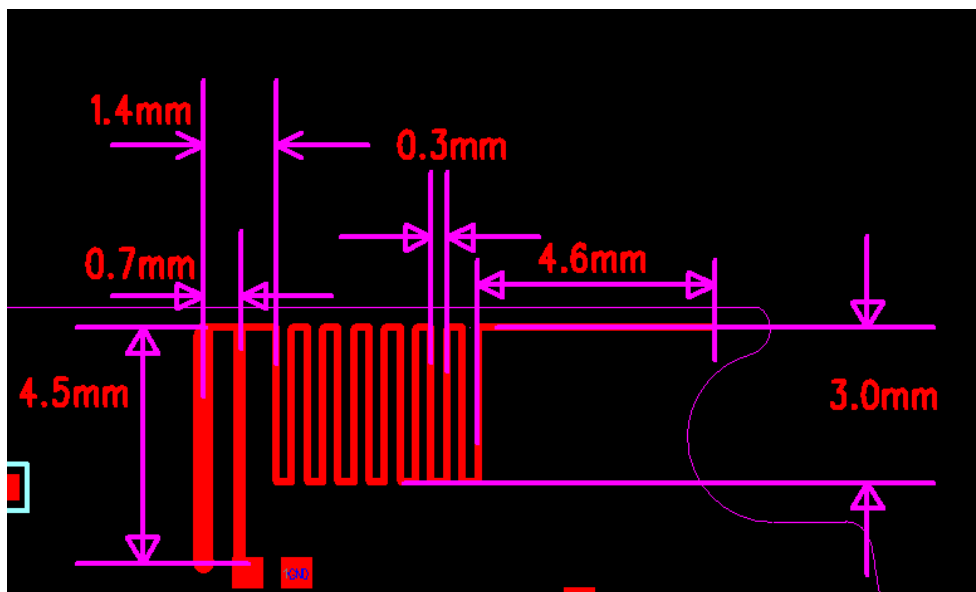

Antenna Gain

Frequency (MHz)	Efficiency(%)	Gain(dBi)
2300	13.17	-1.57
2320	19.08	-0.76
2340	22.65	-0.41
2360	22.62	-0.12
2380	18.03	-0.42
2400	14.86	-0.93
2420	12.54	-1.17
2440	9.92	-2.03
2460	7.46	-2.47
2480	6.11	-2.98
2500	5.39	-3.83

Manufacturer: SHENZHEN HAOHUALIANHE TECHNOLOGY CO.,LTD

Address: 7F, Zhongpengcheng Industrial Park Gongming Street, Guangming New District,
Shenzhen

Model Number: A702PCBANT