

**TURBO<sup>®</sup>**  
**RACING**

# 1:76 RC Semi-Truck



**14+**  
**AGES**

Age-appropriate tips

[www.turboracing.net](http://www.turboracing.net)

Please read the manual before using the product and keep the manual for future use.

## SAFETY INFORMATION

- Movable parts are dangerous, so it is forbidden to put fingers、hair、clothes and other things into the space between the tire and the car body, to avoid being clamped by the rotating parts.
- Please play the car with the following scene:  
Please don't play in places where the car is running or near children, then avoid the risk of collision.  
Please don't play it in sand、water or dust, then avoid trouble.  
Please don't play towards people or animal, then avoid accident.
- For functional requirements, this product contains sharp parts, please follow the correct steps and use methods, pay attention to eye safety.
- Please don't bend or throw the product or play it with rough ways, then avoid an accidents.
- Please don't put this product into water or fire source(such as stove、gas stove,etc.), then avoid accidents.

## THE PACKAGE CONTAINS



1\*Manual

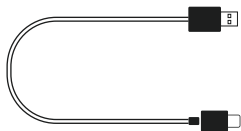

USB&Type-C line \*1

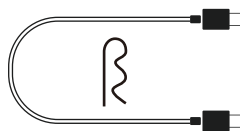

Type-C&Type-C line + 1\*Bind

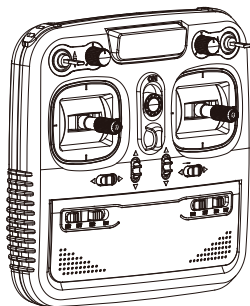

1\*Transmitter



1\* Semi-Truck



1\* Clump weight



Double-sided tape+Rearview mirror sticker

**FUNCTION DESCRIPTION**

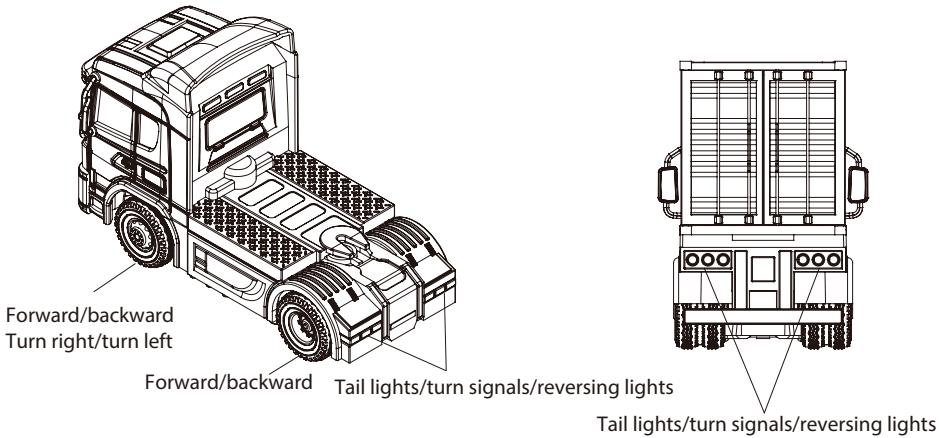
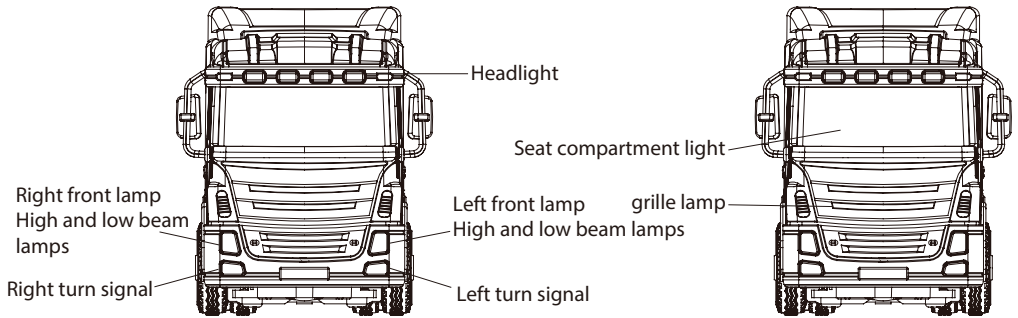

Recharging hole: connect Type-C line

Recharging hole: connect Type-C line

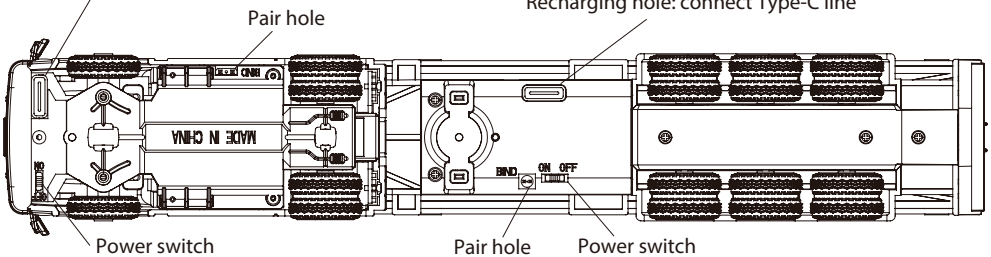

1. The front lights are high and low beams (white light)
2. The rear tail is equipped with tail lights (red light) brake lights
3. The grille light is white light
4. The seat light is blue light
5. The headlights are four color lights (red, green, blue, and white)
6. The reversing light is also a code matching light (white light)
7. The turn signal is orange light

**PREPARE FOR RUN****1 Transmitter battery installation**

This remote uses AA battery or Ni MH battery, when the voltage is lower than  $4.5V \pm 0.2V$ , the LED starts flashing.

**Note: instructions for safe use of the replaceable battery of the remote control:**

1. non rechargeable batteries cannot be charged; rechargeable batteries can only be charged under the supervision of adults.
2. the rechargeable battery shall be removed from the remote control before charging; different types of batteries or old and new batteries cannot Mixed use.
3. the battery shall be placed in the correct polarity; the exhausted battery shall be taken out from the remote control; the power terminal shall not Short circuit to.

**1. Transmitter battery installation. (Picture 1-3)**

1. Open the remote control battery cover.
2. Install according to the polarity mark on the battery box bracketFour new AA batteries.
3. Then close the battery cover. Ensure that the battery cover clicks in In place. Check if it is in the correct position.

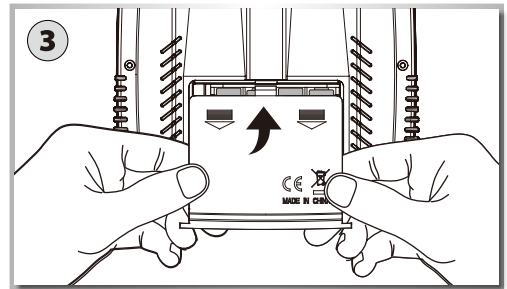
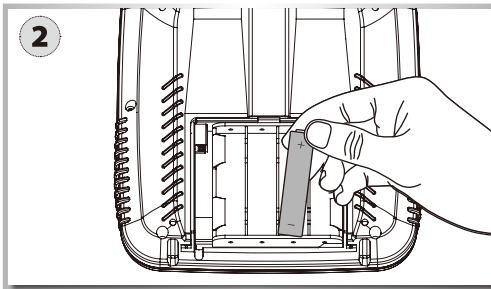
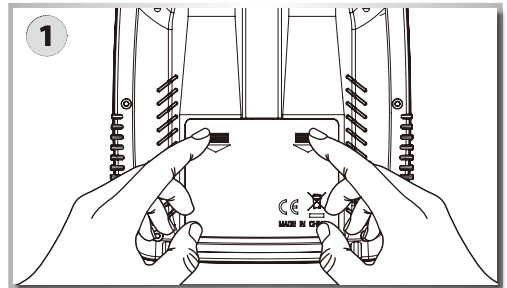

- DO NOT KEEP THE BATTERY IN THE BATTERY COMPARTMENT FOR A LONG TIME TO AVOID BATTERY OXIDATION AND DAMAGE THE PRODUCT.

## 2 Charging

When the car is in power off status, it can be charged in the following two ways; (Please charge the RC car for the first time you use.)

**Tip: When the car is power on, it will not be charged when charging power is inserted. If need charge the car, the car's power switch must be turned "OFF".**

1. Use the hidden Type-C port on the remote to charge the car.(Picture 1-3)

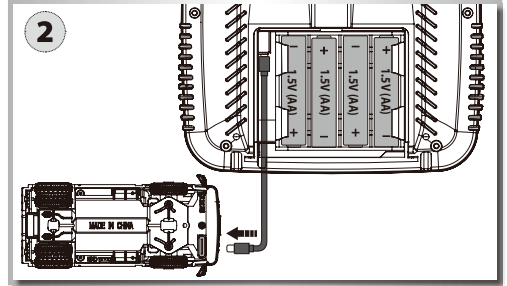
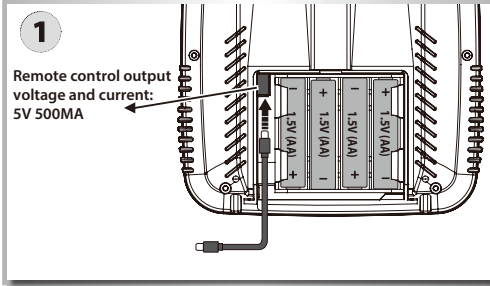

1. Insert the charging cable into the Type-C port of the remote control.

2. The car must be in a shutdown state, and then the charging cable must be connected. Insert the car port for charging.

**Reminder: Remote control output voltage and current: 5V 500MA**

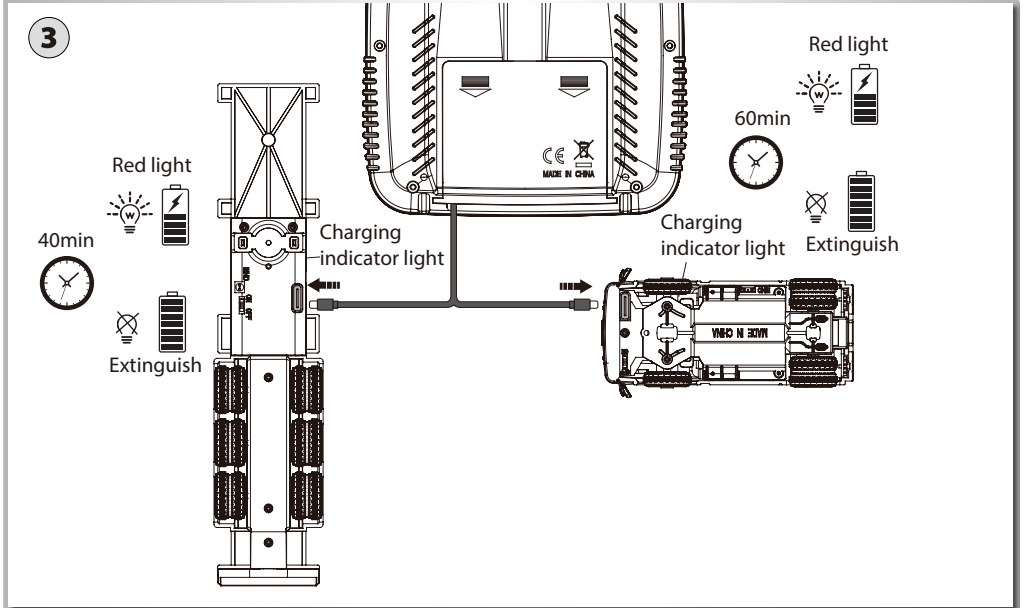

3. At this point, the car's charging indicator light remains on for a long time. If the car's charging indicator light goes out, it indicates that charging is complete.

**Reminder: When charging, the remote control can charge the car when turned on or off.**

2. Insert the attached charging cable into the charging port of the car and connect the power supply for charging. (as picture shows)

**Tip: When the car is power on, it will not be charged when charging power is inserted. If need charge the car, the car's power switch must be turned "OFF".**

The remote control car should be charged by an adult; The charger is not a toy,  
The remote control car can only use the recommended charger (5V/1A);  
Disconnect the remote control car from the charger before cleaning.

**Note: Before charging the car, make sure the charging plug is dry.  
Do not leave when charging the car.**

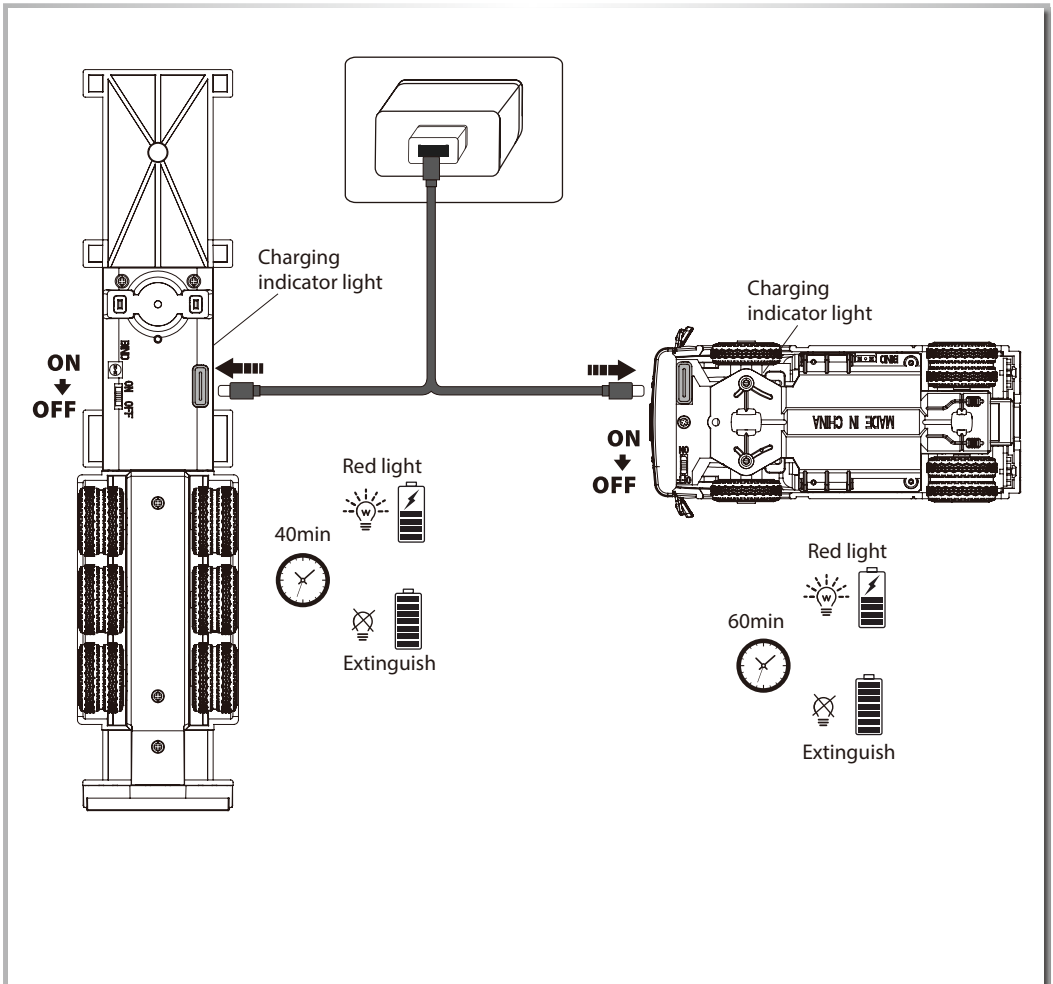

### 3 Turn on/off the power of the car

Car startup: in the shutdown state, turn on the power switch (push to the "on" position),  
The vehicle starts up after the LED lights up for 1 second.

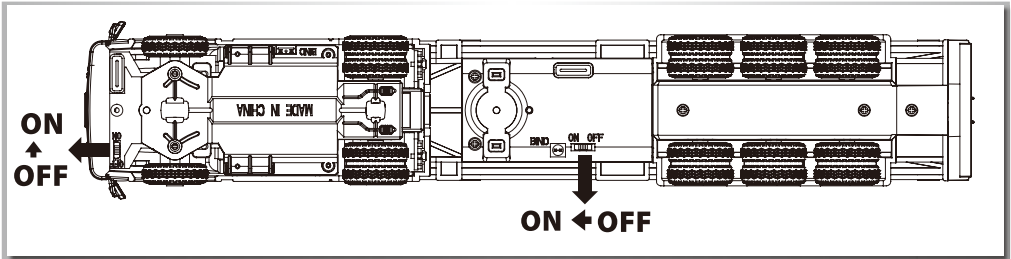

If the front light of the car stays on, it indicates that it's connected with the remote control.

If the front light of the car is flashing, please check whether the power of remote control has been turned on. If yes, you need to re-code the remote control with the car. (See page 10 for details)

Turn off the car: Turn off the power switch, (switch to "OFF" position), the LED goes off and the the car is power off.

### 4 Vehicle battery replacement/peripheral power supply

If it is necessary to disassemble or replace the battery, please pay attention to the correct plug position. If the battery is connected to the external power port, the vehicle will be directly powered on, and plugging it in backwards will cause the power switch to be inoperable, and the vehicle will not be able to charge. Please connect the battery correctly.

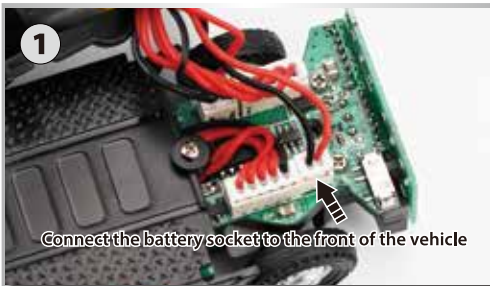

Connect the battery socket to the front of the vehicle

1. Connect the battery socket to the front of the vehicle



Trailer connected to external power port, voltage 3.2-4.2V

2. Connect the trailer to the battery socket, and connect the trailer to the external power port, Voltage 3.2-4.2V

**OPERATION NOTE**

*Note: If you're the first time to use the 1:76 RC car, please take a few minutes to read this statement carefully to get familiar with different features of this operation system.*

**1 Functions Transmitter**

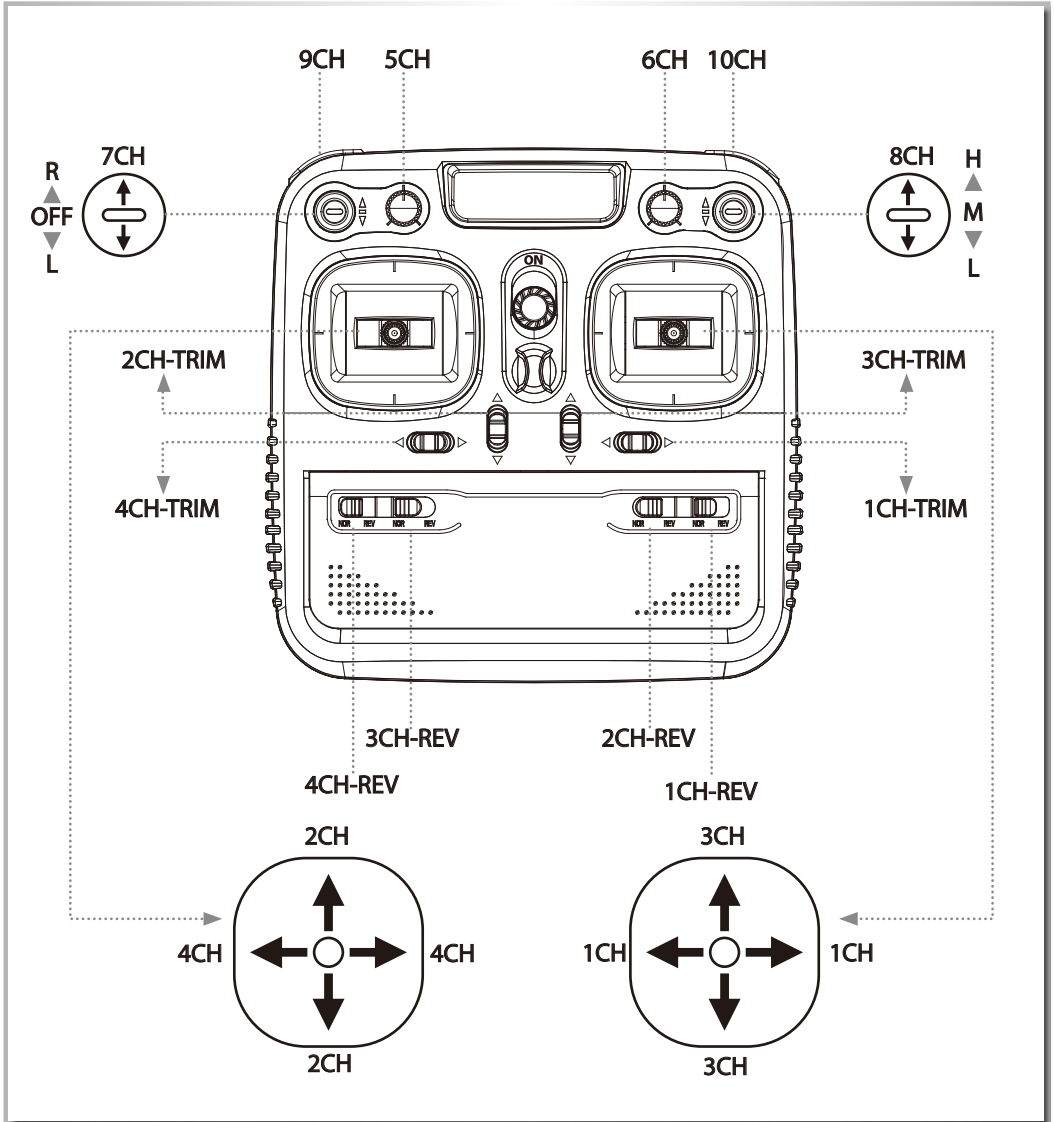



**1CH (direction):** Control left and right turns.

**1CH-REV:** Use the reverse steering switch to reverse the left and right directions.

**2CH (throttle):** Control the throttle to move forward, brake, and backward (Brake lights, backup lights)

**2CH REV:** Using the throttle reverse switch, Reverse the front and rear directions.

**1CH-TRIM:** When the steering lever is at the center point, if the vehicle cannot walk in a straight line, please use steering fine adjustment.

**2CH TRIM:** When the steering lever is at the center point, if the vehicle is moving forward or backward, please use the throttle to adjust it slightly.

**3CH:** Up represents the horn/down represents the turn signal lights on the left and right sides.

**3CH-REV:** Use the CH3-REV reverse switch to reverse the direction of the horn and turn signal.

**4CH:** Cycle left and right to switch headlights (red green blue white)

**4CH-REV:** Use the CH4-REV reverse switch to reverse the order of the headlights.

**5CH:** Control the lifting and lowering of the chassis tripod of the container carriage.

**6CH:** Control the sound switch.

**7CH:** Turn signal quick switch/third gear switch: up for right turn signal on - middle for off - down for Left turn signal.

**8CH:** Fast speed gear/switch up for fast speed Gear - medium speed gear in the middle - slow speed gear down.

**9CH:** Container car:

- Press for the first time: low beam headlights+tail lights
- Press the second time: high beam lights+tail lights
- Press the third time: high beam lights+tail lights+grille lights
- Press the fourth time: high beam lights, tail lights, grille lights, and headlights (this mode can be switched between red, green, blue, and white through the CH4 )
- Press the fifth time: high beam lights, tail lights, grille lights, and headlights (this mode can be switched between red, green, blue, and white through the CH4 )+Seat compartment light
- Press for the sixth time: high beam lights, tail lights, grille lights, and headlights (this mode can be switched between red, green, blue, and white through the CH4 channel)+Seat compartment lights+front and rear fog lights
- Press for the seventh time: high beam lights, tail lights, grille lights, and headlights (this mode can be switched between red, green, blue, and white through the CH4 channel)+Seat lights+front and rear fog lights+hazard warning lights flashing and warning tone
- Press the eighth time to turn off the lights

**10CH:** Container trucks:

- Press the first time: the tail light is on (red light)
- Press for the second time: tail light on (red light)+rear fog light always on (orange light)
- Press the third time: tail light on (red light)+hazard warning light flashing
- Press the fourth time: turn off the lights
- The rear of the container can be synchronized with the front of the vehicle: the brake light/reversing light/turn signal light/reversing light is (white light) and is also a matching light

## 2 Remote control battery case

When installing a new battery case for the remote control, pay attention to the positive and negative poles of the JST plug, do not plug it in backwards!

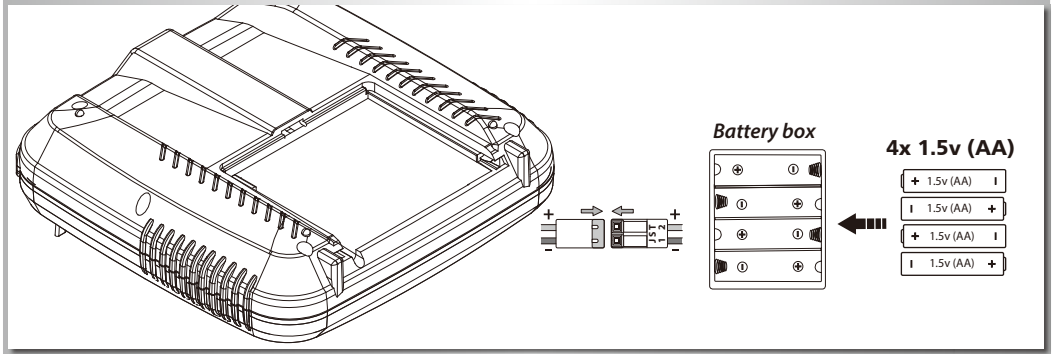

## 3 Binding

1. Switch on the transmitter.

2. Turn on the power switch on the car, and the front light on the car flashes.

3. Using the binding pin plug into the BIND hole to pair the truck to the remote, and the vehicle's tail light LED changes from flashing to off, indicates that the remote control has successfully paired with the vehicle.

Reminder: Both the tractor and trailer should be paired.

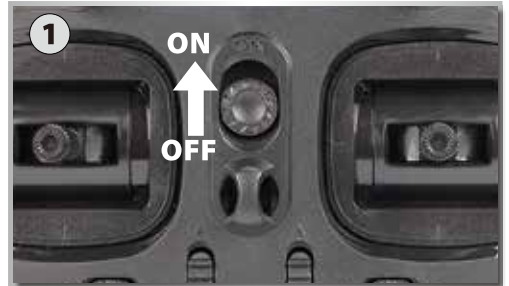

*Tip: If fail binding, please turn off the power switch of the car and remote, and restart the binding.*

*Note: The rc car has been connected to the remote. The above procedure is only necessary when use a new remote or car.*

Turn off the car: Please turn off the power switch of the car first, and then turn off the power switch of the remote to prevent the car from losing control.

#### 4 Car running settings

1

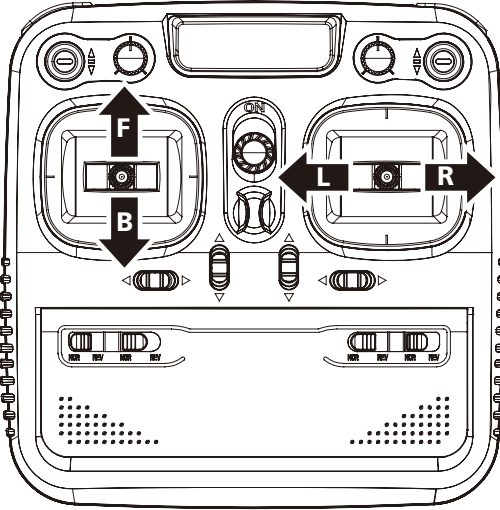

- **Throttle trigger:** Control forward / brake /backward.
- **Steering wheel:** Control left / right steering.

Forward/speed up  
Left ↑ Right

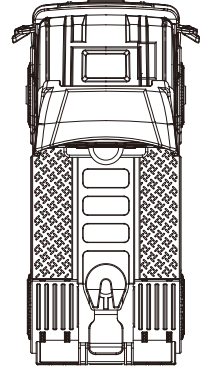

↓  
Brake /Backward

2

- **1CH/TRIM:** When the steering wheel in the middle position, if the front wheel is not in a straight line, please adjust it with 1CH/TRIM "+" or "-" button.

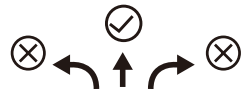
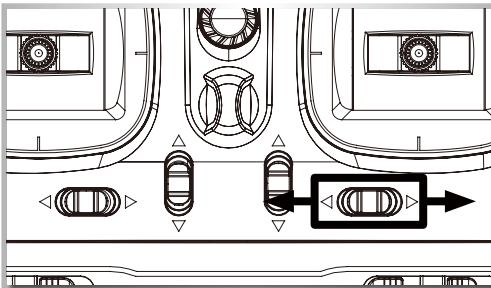

Linearity

## SPECIFICATION

Product name	1: 76 RC Tractor	Model	C50-T
Driving distance	30m	Scale	1:76
Slope angle	30°	Driving time	40min
Drive mode	Four-wheel drive	Size	80x41x49.3mm
Proportional steering	Proportional steering	Battery	3.7V、 150mAh lithium battery Note: The lithium battery is built-in and detachable
Weight	55g		

Product name	1: 76 RC Trailer	Model	C50-C
Driving distance	30M	Scale	1:76
Weight	40g	charging time	40min
Size	161.7x35x56.2mm	Battery	3.7V、 75mAh lithium battery Note: The lithium battery is built-in and detachable

## LED LIGHT STATUS TABLE

Display	Status
The tail lights of the vehicle flash once every 2 seconds	Please check whether the power of remote control has been turned on, if yes, you need to re-code the remote control with the car
The tail lights of the vehicle are off	The remote control is connected to the car and can be operated
The front and tail lights are off	The vehicle is in a shutdown state and the battery is low; CH9, closed state; CH10, closed state

**PRODUCT PERFORMANCE FAILURE TABLE**

Product Name	Product performance failure
1: 76 RC Semi-Truck	<ol style="list-style-type: none"><li>1. The product cannot be turned on.</li><li>2. Cannot charge.</li><li>3. Unable to operate.</li><li>4. Dysfunction.</li></ol>

**MAINTENANCE**

1. Before using the product, please ensure that all components have been tightened, check and clear foreign matter in the gap between the wheel and chassis.
2. When the car is to be stored for a long time, it should be kept at 70% of its power to maximize battery life. And charge the battery once every 1-3 months to avoid battery damage. (It is recommended to fully charge the battery and store it after 5-10 minutes of use).
3. If the remote control will not be used for a long time, please remove the batteries to avoid oxidation.

## TROUBLESHOOTING

Fault symptom	Cause of failure	Solutions
The transmitter connection failed	<ol style="list-style-type: none"> <li>1. Distance is too far</li> <li>2. Multicars pairing at the same time</li> </ol>	Make sure that the product is in car receiving mode.(The headlights flash).
Freeze	Foreign object between the wheels	Check the wheels for foreign objects
No reaction when remote control left and right steering / no response when steering	The steering angle is set too small	Clean foreign objects between the wheels Restart the remote control and vehicle
The steering is in the opposite direction of the remote steering operation	The remote steering reverse switch is not properly set	Set the remote steering reverse switch to the correct direction
When the throttle is in neutral position, the car immediately starts to move forward or backward	The throttle fine-tuning does not set to the center position	Set the remote throttle fine-tuning to the center position
The car cannot move in a straight line/The left and right steering radius is significantly different	Steering fine-tuning is not set to the center position	Set the steering fine-tuning to the center position
The maximum speed cannot be reached	<ol style="list-style-type: none"> <li>1. The speed gear setting is too small</li> <li>2. Low battery level</li> <li>3. There are foreign objects between the wheels</li> </ol>	Set the remote control gear to maximum, And check for foreign objects and battery power between the wheels Is the quantity sufficient
Overheating in the motor part	Ambient temperature is too high	The car should be immediately turned off and placed in a cool, well-ventilated place for cooling to avoid damage to electronic parts
The power-on light is not on	The voltage is less than 3.0V and there is not enough power	Charge in a timely manner
Shutdown		

## PRECAUTION

- The car contains lithium batteries. Disassembling, striking, squeezing or throwing the car into the fire is prohibited. If severe swelling occurs, do not continue to use it. Do not place it in high-temperature environment.
- Due to the special feature of lithium batteries, overly high or low temperature will affect the battery charge and discharge performance and battery life, so please do not use or store this product under environments such as high temperature, low temperature, high humidity or direct sunlight.
- The charging cable, plug, body shell, and other parts must be checked regularly for damage. If the damage is found, stop using until the repair is complete.
- The car has low battery voltage protection.
- When the battery voltage is lower than 3.0V, it will automatically cut off the current and the car will seize all functions to protect the battery.
- When using remote control nearby high-voltage power lines, light rails, microwave ovens electric waves of the same frequency will lead to dysfunction of the car. Please change the location or choose another time to operate.
- Our company holds no responsibility if accidents such as injury to others or damage due to operating errors.

## NON-WARRANTY REGULATIONS

- Unauthorized repair, misuse, collision, negligence, abuse, fluid intake, accidents, alterations, incorrect use. Non-product accessories, or tear, alter marks and anti-counterfeiting marks;
- The validity period of "three guarantees" has passed.
- Damage caused by force majeure;
- Does not meet the performance failures listed in "performance failure table of 1: 76 RC Semi-Truck";
- Performance failure of the product and its accessories that meets the "performance failure table of 1: 76 RC Semi-Truck" due to human factors.

### 1. Return and exchange services require confirmation.

When the client applies for return and exchange, it is necessary to follow the 1: 76 RC Semi-Truck warranty instructions and the customer service should confirm whether it meets the after-sales conditions and then arrange relevant service.

Notice: The products, accessories, remote control, etc. in the instruction manual are schematic diagrams and for reference only. Due to product updates and upgrades the physical and schematics of the product may differ slightly, please refer to the actual product.

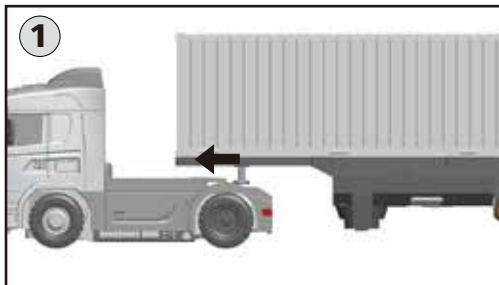
**INSTALLATION OF SEMI-TRUCK**

1. Insert the trailer bottom hook along the locking position.

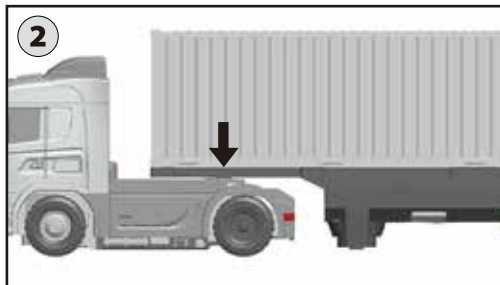

2. Then proceed downwards.

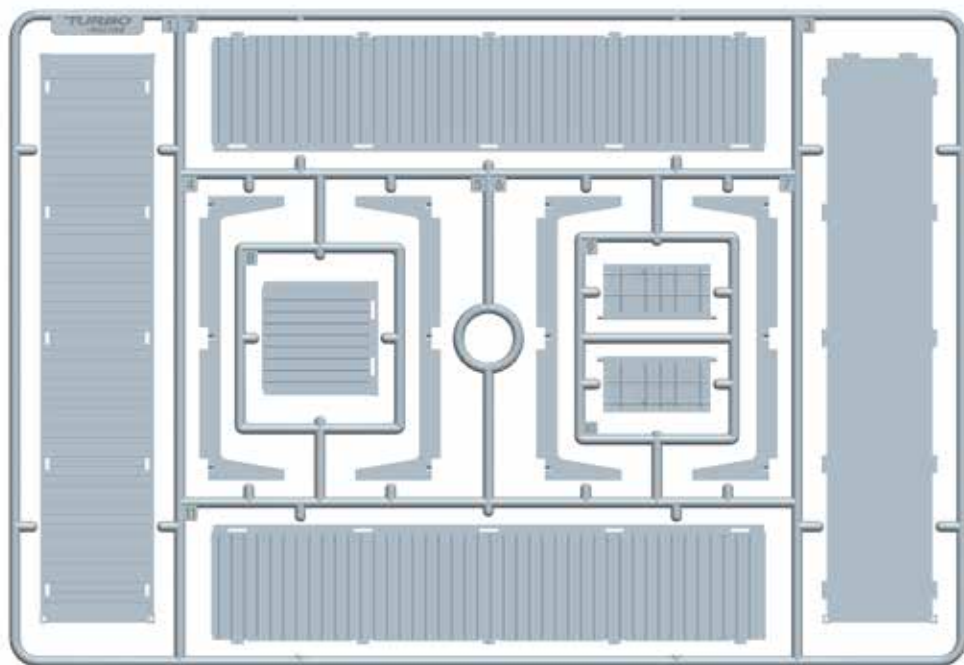
**CONTAINER ACCESSORIES DIAGRAM**



**ASSEMBLY METHOD OF CONTAINER ACCESSORIES****1.****2.****3.****4.****5.****6.****7.****8.****9.**

**General assembly drawing**



**Tractor explosion diagram**

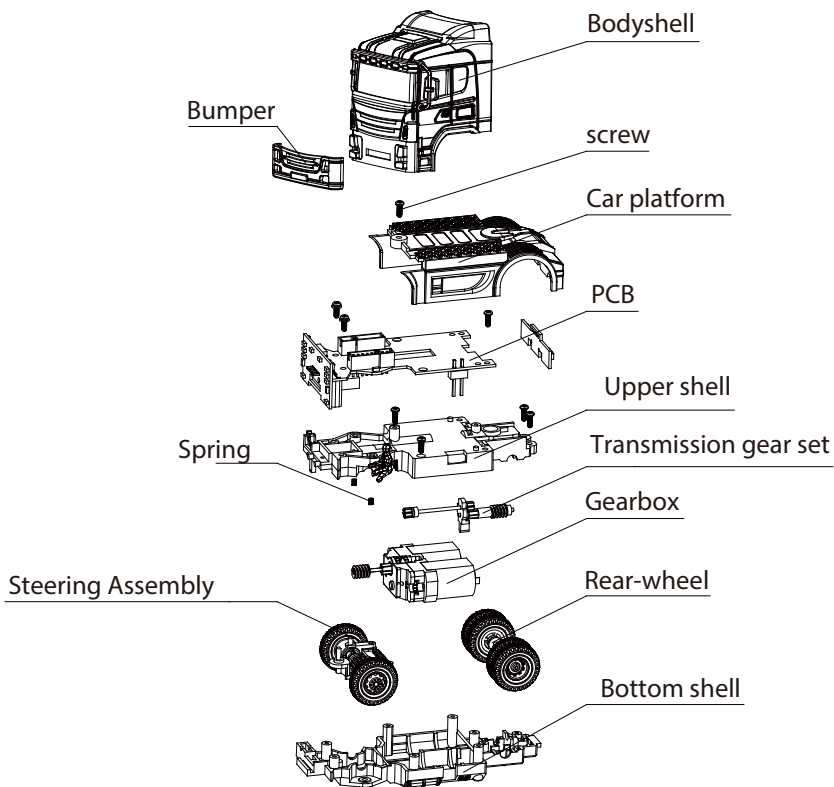

**Explosion diagram of car shell**

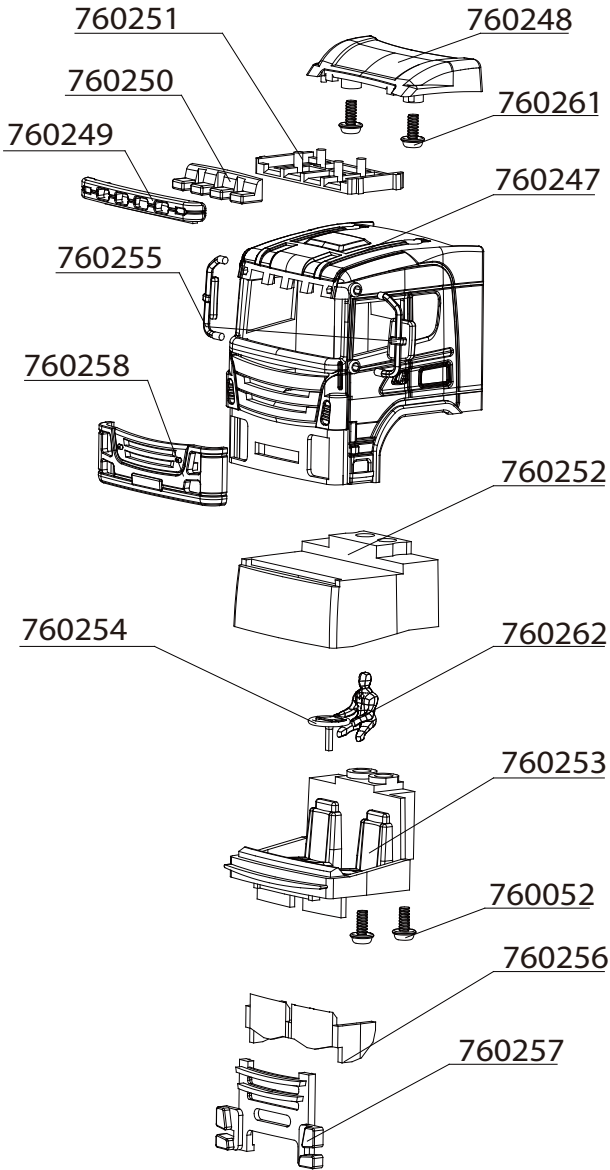

**Tractor transmission shaft**

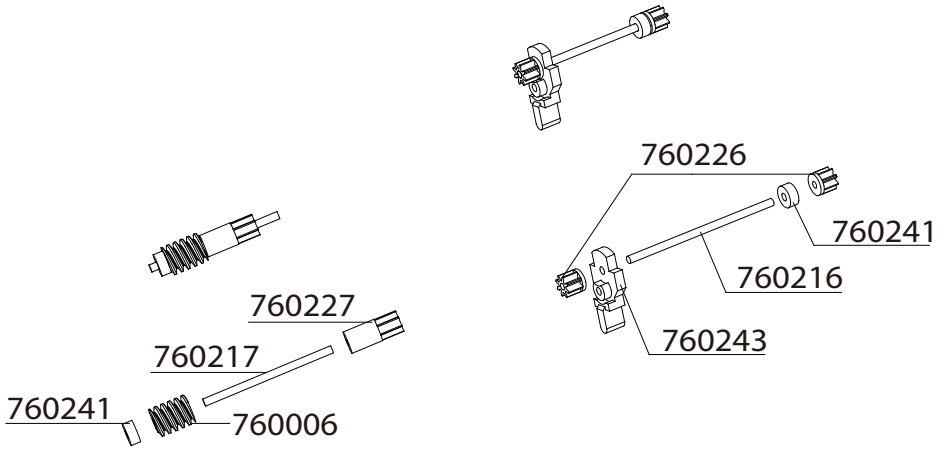

**Tractor rear wheel**

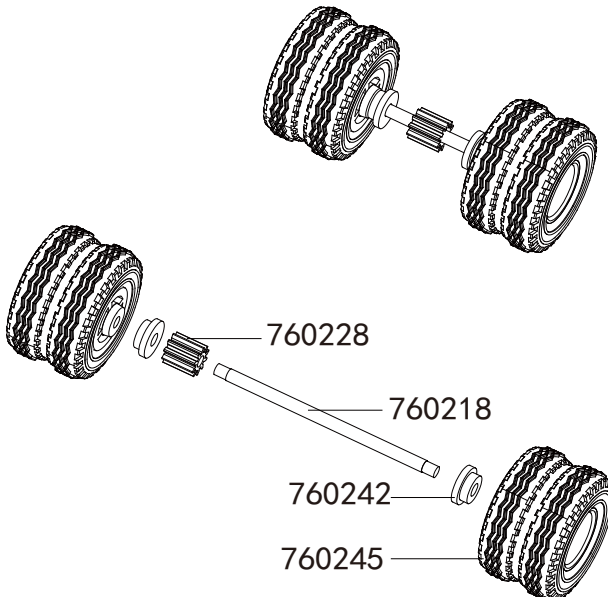

**Tractor steering**

