



FCC TEST REPORT

FCC ID: 2ARE7-P21

On Behalf of

ShenZhenShi NewStone Technology Co., Ltd

2.4G Transmitter

Model No.: P21

Prepared for : ShenZhenShi NewStone Technology Co., Ltd
Address : B2 blvd, YuHong Industrial Park, No.20, XingYe West Road, ShaJing
Town, ShenZhen, China

Prepared By : Shenzhen Alpha Product Testing Co., Ltd.
Address : Building i, No.2, Lixin Road, Fuyong Street, Bao'an District, 518103,
Shenzhen, Guangdong, China

Report Number : A2105193-C01-R04
Date of Receipt : May 26, 2021
Date of Test : May 26, 2021-June 1, 2021
Date of Report : June 2, 2021
Version Number : V0

TABLE OF CONTENTS

Description	Page
1. Summary of Standards And Results	6
1.1. Description of Standards and Results	6
2. General Information.....	7
2.1. Description of Device (EUT).....	7
2.2. Accessories of Device (EUT)	8
2.3. Tested Supporting System Details	8
2.4. Block Diagram of connection between EUT and simulators	8
2.5. Test Mode Description.....	8
2.6. Test Conditions	8
2.7. Additional instructions.....	9
2.8. Test Facility	10
2.9. Measurement Uncertainty.....	10
2.10. Test Equipment List	11
3. Maximum Peak Output power	12
3.1. Limit	12
3.2. Test Procedure	12
3.3. Test Setup.....	12
3.4. Test Result	12
4. Bandwidth.....	13
4.1. Limit	13
4.2. Test Procedure	13
4.3. Test Result	13
5. Carrier Frequency Separation.....	17
5.1. Limit	17
5.2. Test Procedure	17
5.3. Test Result	17
6. Number Of Hopping Channel.....	18
6.1. Limit	18
6.2. Test Procedure	18
6.3. Test Result	18
7. Dwell Time.....	19
7.1. Test limit	19
7.2. Test Procedure	19
7.3. Test Result	19
8. Radiated emissions.....	21
8.1. Limit	21
8.2. Block Diagram of Test setup	22
8.3. Test Procedure	23
8.4. Test Result	23

9. Band Edge Compliance	29
9.1. Block Diagram of Test Setup	29
9.2. Limit	29
9.3. Test Procedure	29
9.4. Test Result	29
10. Power Line Conducted Emissions	33
10.1. Block Diagram of Test Setup	33
10.2. Limit	33
10.3. Test Procedure	33
10.4. Test Result	33
11. Antenna Requirements	34
11.1. Limit	34
11.2. Result	34
12. Test setup photo	35
12.1. Photos of Radiated emission.....	35
13. Photos of EUT	36

TEST REPORT DECLARATION

Applicant : ShenZhenShi NewStone Technology Co., Ltd

Address : B2 blvd, YuHong Industrial Park, No.20, XingYe West Road, ShaJing Town,
ShenZhen, China

Manufacturer : ShenZhenShi NewStone Technology Co., Ltd

Address : B2 blvd, YuHong Industrial Park, No.20, XingYe West Road, ShaJing Town,
ShenZhen, China

EUT Description : 2.4G Transmitter

(A) Model No. : P21

(B) Trademark : N/A

Measurement Standard Used:

FCC Rules and Regulations Part 15 Subpart C Section 15.247

ANSI C63.10:2013

The device described above is tested by Shenzhen Alpha Product Testing Co., Ltd. to determine the maximum emission levels emanating from the device. The maximum emission levels are compared to the FCC Part 15 Subpart C limits both conducted and radiated emissions. The test results are contained in this test report and Shenzhen Alpha Product Testing Co., Ltd. is assumed of full responsibility for the accuracy and completeness of these tests.

After the test, our opinion is that EUT compliance with the requirement of the above standards.

This report applies to above tested sample only. This report shall not be reproduced in parts without written approval of Shenzhen Alpha Product Testing Co., Ltd.

Tested by (name + signature).....: Lucas Pang
Project Engineer



Approved by (name + signature).....: Simple Guan
Project Manager



Date of issue..... : June 2, 2021

Revision History

Revision	Issue Date	Revisions	Revised By
V0	June 2, 2021	Initial released Issue	Lucas Pang

1. SUMMARY OF STANDARDS AND RESULTS

1.1. Description of Standards and Results

The EUT have been tested according to the applicable standards as referenced below:

Test Item	Standards Paragraph	Result
Maximum Peak Output Power	FCC Part 15: 15.247(b)(1) ANSI C63.10 :2013	P
Bandwidth	FCC Part 15: 15.215 ANSI C63.10 :2013	P
Carrier Frequency Separation	FCC Part 15: 15.247(a)(1) ANSI C63.10 :2013	P
Number Of Hopping Channel	FCC Part 15: 15.247(a)(1)(iii) ANSI C63.10 :2013	P
Dwell Time	FCC Part 15: 15.247(a)(1)(iii) ANSI C63.10 :2013	P
Radiated Emission	FCC Part 15: 15.209 FCC Part 15: 15.247(d) ANSI C63.10 :2013	P
Band Edge Compliance	FCC Part 15: 15.247(d) ANSI C63.10 :2013	P
Power Line Conducted Emissions	FCC Part 15: 15.207 ANSI C63.10 :2013	N/A
Antenna requirement	FCC Part 15: 15.203	P
Note:	1. P is an abbreviation for Pass. 2. F is an abbreviation for Fail. 3. N/A is an abbreviation for Not Applicable.	

2. GENERAL INFORMATION

2.1. Description of Device (EUT)

Description : 2.4G Transmitter

Model Number : P21

Diff : N/A

Trademark : N/A

Test Voltage : DC 6V from battery

Operation
frequency : 2405-2478MHz

Channel No. : 73 Channels

Modulation type : GFSK

Antenna Type : Internal Antenna, Maximum Gain is 2.5dBi

Software version : V1.0

Hardware version : V1.0

2.2. Accessories of Device (EUT)

Accessory 1 : N/A

2.3. Tested Supporting System Details

No.	Description	Manufacturer	Model	Serial Number	Certification or SDOC
1	N/A	N/A	N/A	N/A	N/A

2.4. Block Diagram of connection between EUT and simulators

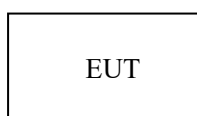

2.5. Test Mode Description

Tested mode, channel, and data rate information		
Mode	Channel	Frequency (MHz)
GFSK	Low :CH1	2405
	Middle: CH37	2441
	High: CH73	2478
	Hopping	2405-2478

2.6. Test Conditions

Items	Required	Actual
Temperature range:	15-45°C	27°C
Humidity range:	25-75%	56%
Pressure range:	86-106kPa	98kPa

2.7. Additional instructions

The operation (Used for test) from client

Mode	Special operated method is used. The operation provided by client to enable the EUT under transmission condition continuously at specific channel frequencies individually.		
Power level setup in software			
Mode	Channel	Frequency (MHz)	Soft Set
GFSK	CH1	2405	TX level is set as defaults value.
	CH37	2441	
	CH73	2478	
	Hopping	2405-2478	

Note: New batteries were used during all testing.

2.8. Test Facility

Shenzhen Alpha Product Testing Co., Ltd

Building i, No.2, Lixin Road, Fuyong Street, Bao'an District, 518103,
Shenzhen, Guangdong, China

June 21, 2018 File on Federal Communication Commission

Registration Number: 293961

Designation Number: CN1236

July 15, 2019 Certificated by IC

Registration Number: CN0085

2.9. Measurement Uncertainty

(95% confidence levels, k=2)

Item	Uncertainty
Uncertainty for Power point Conducted Emissions Test	2.77dB
Uncertainty for Radiation Emission test in 3m chamber (below 30MHz)	2.16 dB(Polarize: V)
	2.62dB(Polarize: H)
Uncertainty for Radiation Emission test in 3m chamber (30MHz to 1GHz)	3.76dB(Polarize: V)
	3.82dB(Polarize: H)
Uncertainty for Radiation Emission test in 3m chamber (1GHz to 25GHz)	4.22dB(Polarize: H)
	4.18dB(Polarize: V)
Uncertainty for radio frequency	5.6×10^{-8}
Uncertainty for conducted RF Power	0.39dB
Uncertainty for temperature	0.2°C
Uncertainty for humidity	1%
Uncertainty for DC and low frequency voltages	0.06%

2.10. Test Equipment List

Equipment	Manufacture	Model No.	Serial No.	Last cal.	Cal Interval
9*6*6 anechoic chamber	CHENYU	9*6*6	N/A	2019.09.06	3Year
Spectrum analyzer	ROHDE&SCHWARZ	FSV40-N	102137	2020.09.02	1 Year
Spectrum analyzer	Agilent	N9020A	MY499100060	2020.09.02	1 Year
Receiver	ROHDE&SCHWARZ	ESR	1316.3003K03-10208 2-Wa	2020.09.02	1 Year
Receiver	R&S	ESCI	101165	2020.09.02	1 Year
Bilog Antenna	Schwarzbeck	VULB 9168	VULB9168-438	2020.04.12	2Year
Horn Antenna	SCHWARZBECK	BBHA 9120 D	BBHA 9120 D(1201)	2020.04.12	2Year
Active Loop Antenna	SCHWARZBECK	FMZB 1519B	00059	2019.09.07	2Year
Cable	Resenberger	N/A	No.1	2020.09.02	1 Year
Cable	Resenberger	N/A	No.2	2020.09.02	1 Year
Cable	Resenberger	N/A	No.3	2020.09.02	1 Year
Pre-amplifier	HP	HP8347A	2834A00455	2020.09.02	1 Year
Pre-amplifier	Agilent	8449B	3008A02664	2020.09.02	1 Year
L.I.S.N.#1	Schwarzbeck	NSLK8126	8126466	2020.09.02	1 Year
L.I.S.N.#2	ROHDE&SCHWARZ	ENV216	101043	2020.09.02	1 Year
20db Attenuator	ICPROBING	IATS1	82347	2020.09.02	1 Year
Horn Antenna	SCHWARZBECK	BBHA9170	00946	2019.09.07	2 Year
Preamplifier	SKET	LNPA_1840-50	SK2018101801	2020.09.02	1 Year
Power Meter	Agilent	E9300A	MY41496625	2020.09.02	1 Year
Temp. & Humid. Chamber	Weihuang	WHTH-1000-40-8 80	100631	2020.09.02	1 Year
Switching Mode Power Supply	JUNKE	JK12010S	20140927-6	2020.09.02	1 Year

3. MAXIMUM PEAK OUTPUT POWER

3.1.Limit

Please refer section 15.247.

For frequency hopping systems operating in the 2400-2483.5 MHz band employing at least 75 non-overlapping hopping channels, and all frequency hopping systems in the 5725-5850 MHz band: 1 watt. For all other frequency hopping systems in the 2400-2483.5 MHz band: 0.125 watts, the e.i.r.p shall not exceed 4W

3.2.Test Procedure

The transmitter output is connected to the RF Power Meter. The RF Power Meter is set to the peak power detection.

3.3.Test Setup

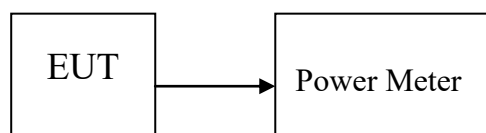

3.4.Test Result

Mode	Freq (MHz)	PK Output Power (dBm)	PK Output Power (mW)	Limit (dBm)	Result
GFSK	2405	14.287	26.835	21.00	Pass
	2441	14.322	27.052	21.00	Pass
	2478	11.866	15.367	21.00	Pass
Conclusion: Pass					

4. BANDWIDTH

4.1.Limit

Intentional radiators operating under the alternative provisions to the general emission limits, as contained in §§ 15.217 through 15.257 and in Subpart E of this part, must be designed to ensure that the 20 dB bandwidth of the emission, or whatever bandwidth may otherwise be specified in the specific rule section under which the equipment operates, is contained within the frequency band designated in the rule section under which the equipment is operated.

4.2.Test Procedure

The transmitter output was directly connected to a spectrum analyzer with a 50Ω cable. The bandwidth of the fundamental frequency was measured by spectrum analyzer with 30kHz RBW and 100kHz VBW. The 20dB bandwidth is defined as the total spectrum the power of which is higher than peak power minus 20dB.

4.3.Test Result

Condition	Mode	Frequency (MHz)	Antenna	99% OBW (MHz)	-20 dB Bandwidth (MHz)	Limit -20 dB Bandwidth (MHz)	Verdict
NVNT	user	2405	Ant 1	0.5003	0.5272	/	Pass
NVNT	user	2441	Ant 1	0.9505	1.0454	/	Pass
NVNT	user	2478	Ant 1	0.9649	1.0874	/	Pass

OBW NVNT user 2405MHz Ant1

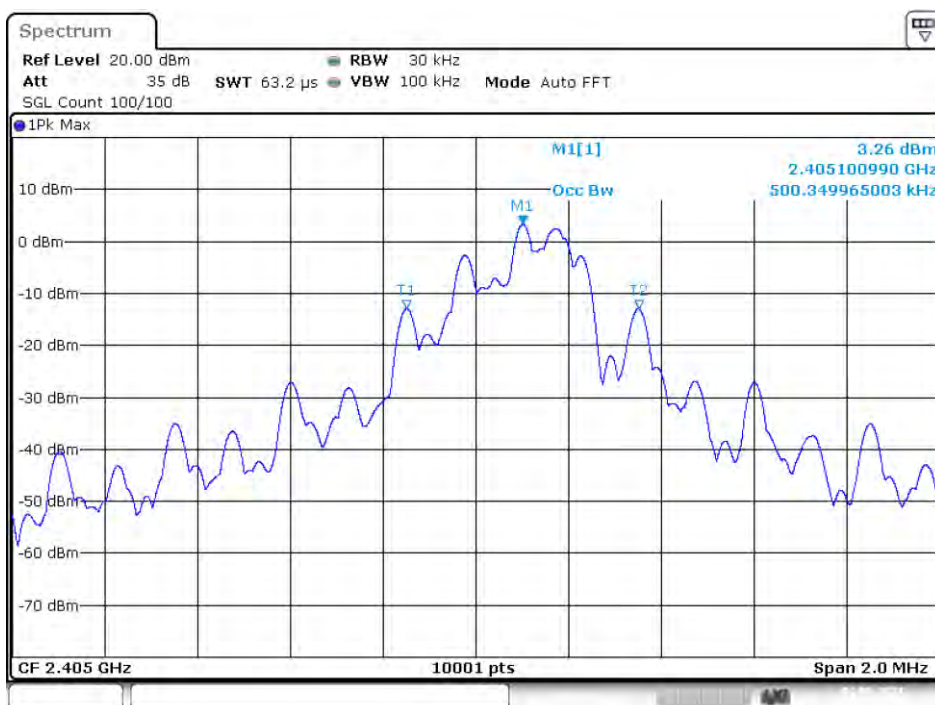

Date: 1.JUN.2021 11:27:59

-20 dB BW NVNT user 2405MHz Ant1

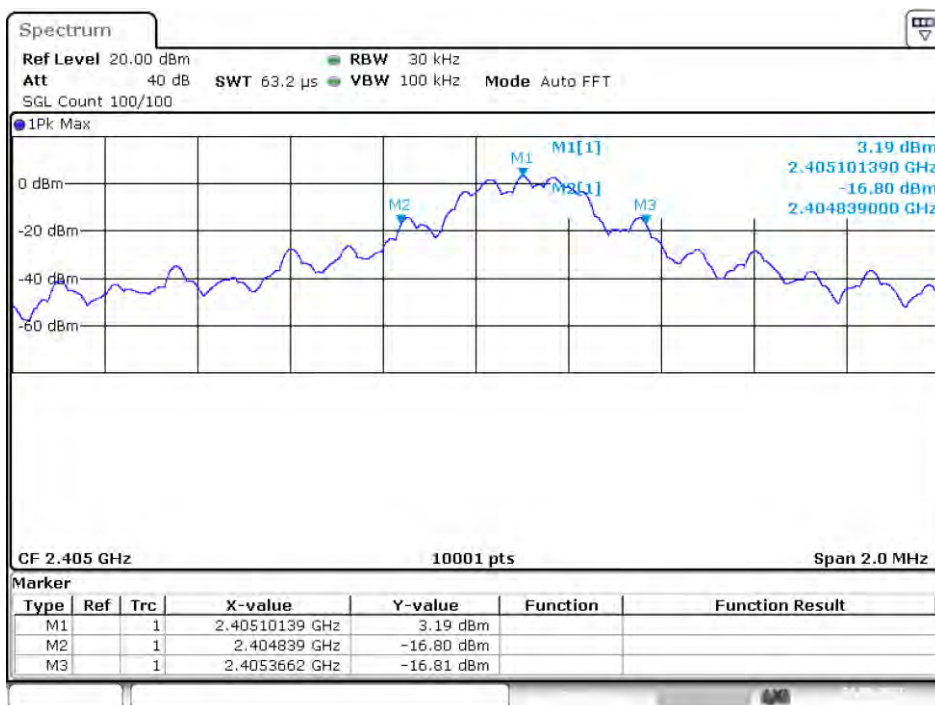

Date: 1.JUN.2021 11:28:02

OBW NVNT user 2441MHz Ant1



Date: 1. JUN. 2021 11:32:11

-20 dB BW NVNT user 2441MHz Ant1

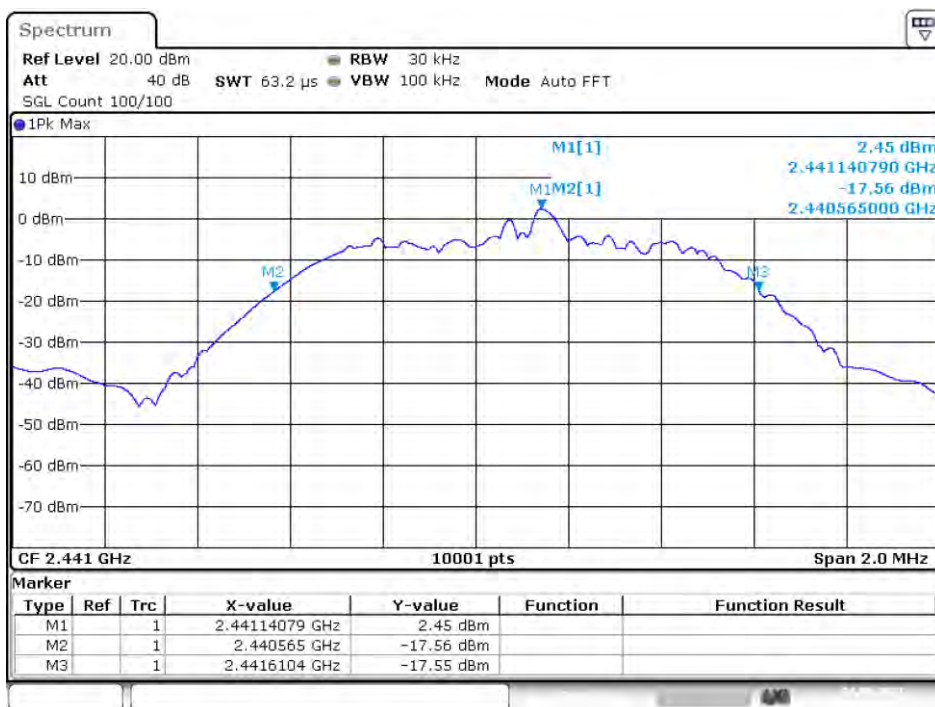

Date: 1. JUN. 2021 11:32:14

OBW NVNT user 2478MHz Ant1

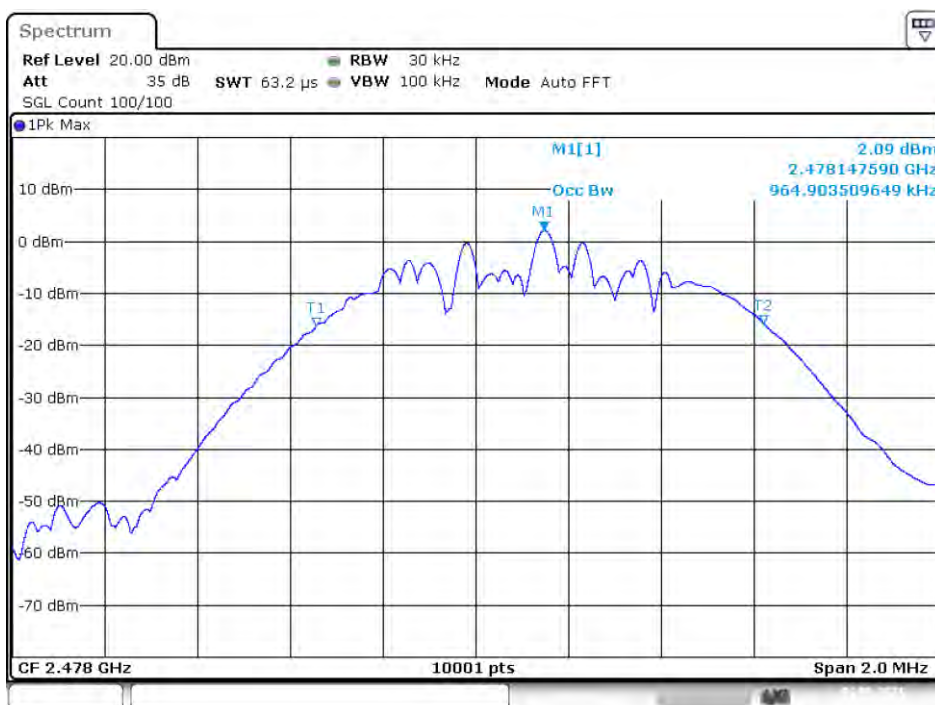

Date: 1.JUN.2021 11:42:02

-20 dB BW NVNT user 2478MHz Ant1

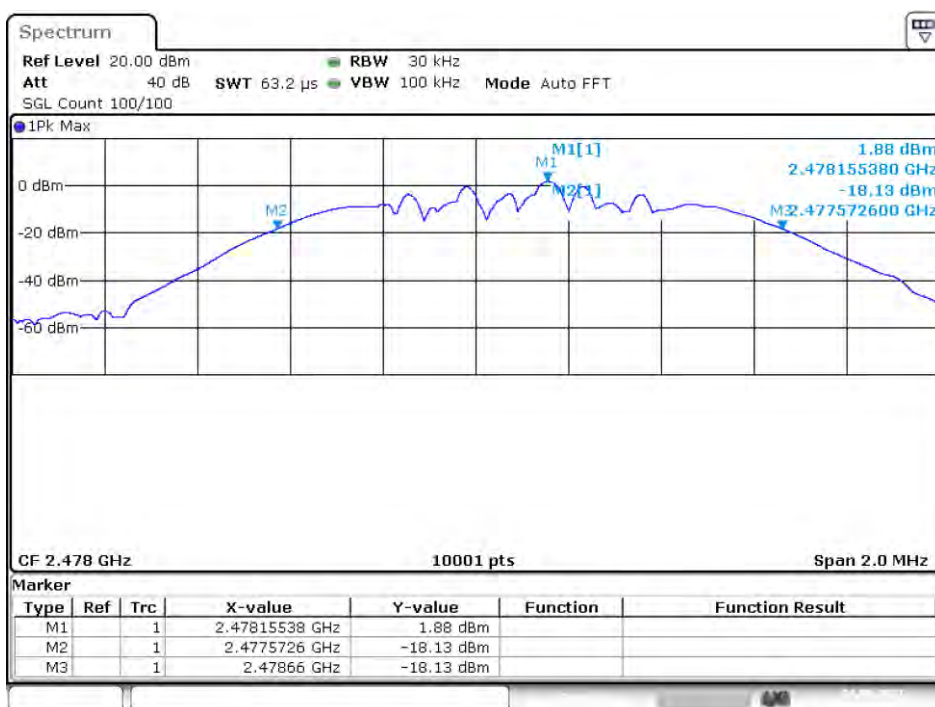

Date: 1.JUN.2021 11:42:05

5. CARRIER FREQUENCY SEPARATION

5.1.Limit

Frequency hopping systems shall have hopping channel carrier frequencies separated by a minimum of 25 kHz or the 20 dB bandwidth of the hopping channel, whichever is greater. Alternatively, frequency hopping systems operating in the 2400-2483.5 MHz band may have hopping channel carrier frequencies that are separated by 25 kHz or two-thirds of the 20 dB bandwidth of the hopping channel, whichever is greater, provided the systems operate with an output power no greater than 125 mW

5.2.Test Procedure

The transmitter output was directly connected to a spectrum analyzer with a 50Ω cable. The carrier frequency was measured by spectrum analyzer with 100kHz RBW and 300kHz VBW.

5.3.Test Result

Condition	Mode	Hopping Freq1 (MHz)	Hopping Freq2 (MHz)	HFS (MHz)	Limit (MHz)	Verdict
NVNT	user	2441.042	2442.032	0.99	0.667	Pass

CFS NVNT user 2441MHz

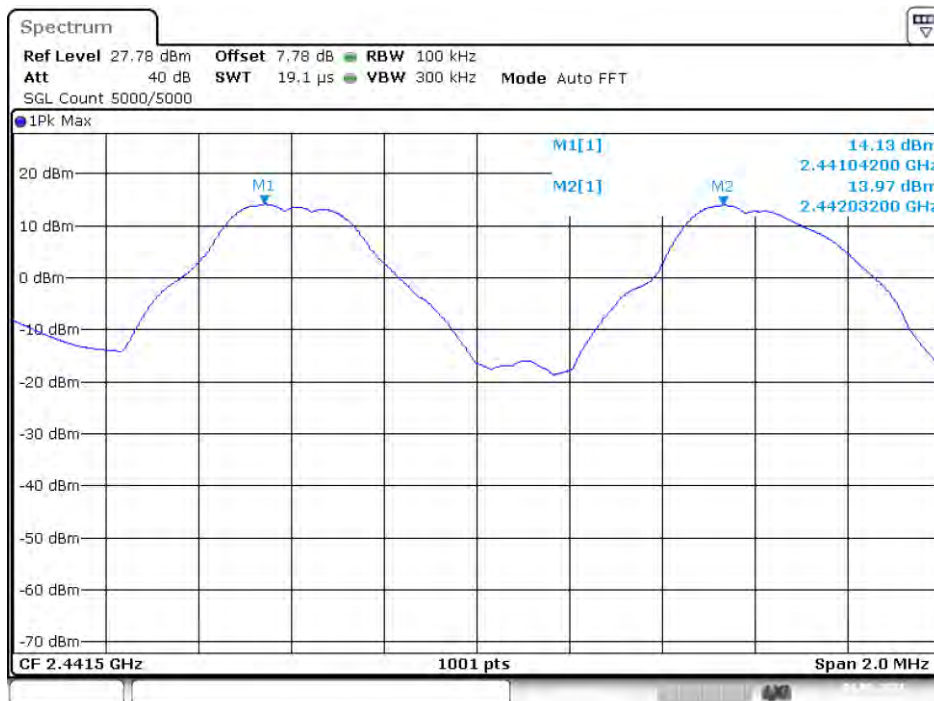

Date: 1.JUN.2021 11:20:20

6. NUMBER OF HOPPING CHANNEL

6.1.Limit

Frequency hopping systems in the 2400-2483.5 MHz band shall use at least 15 channels

6.2.Test Procedure

The transmitter output was directly connected to a spectrum analyzer with a 50Ω cable. The number of hopping channel was measured by spectrum analyzer with 100kHz RBW and 300KHz VBW.

6.3.Test Result

Condition	Mode	Hopping Number	Limit	Verdict
NVNT	user	73	15	Pass

Hopping No. NVNT user 2441MHz

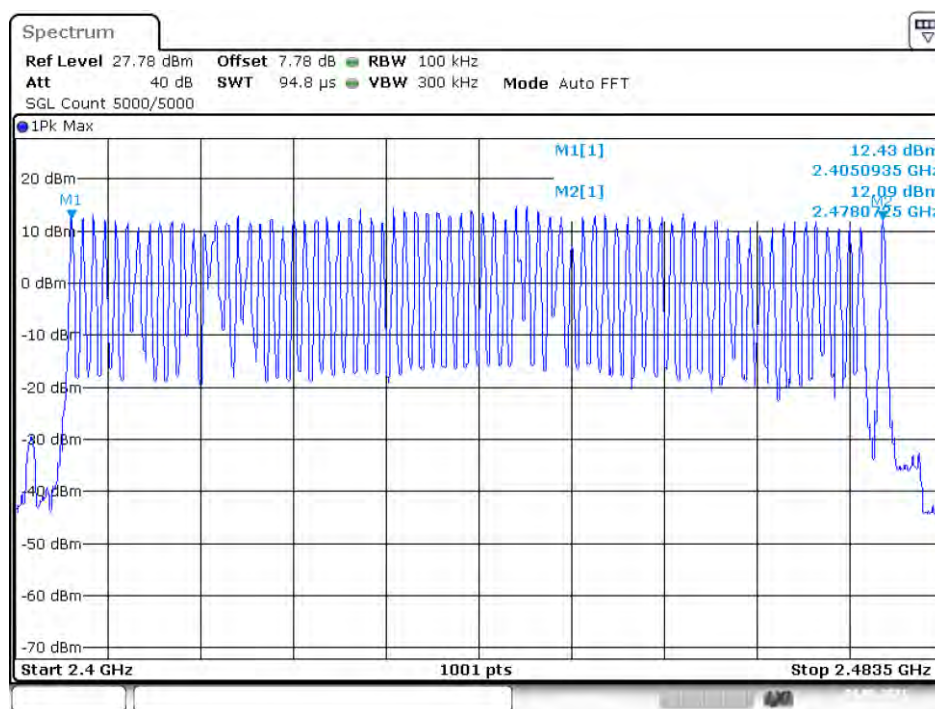

Date: 1.JUN.2021 11:19:42

7. DWELL TIME

7.1. Test limit

Please refer section 15.247

According to §15.247(a)(1)(iii), Frequency hopping systems operating in the 2400MHz-2483.5 MHz. The average time of occupancy on any frequency shall not be greater than 0.4 s within period of 0.4 seconds multiplied by the number of hopping channels employed.

7.2. Test Procedure

7.2.1. Place the EUT on the table and set it in transmitting mode.

7.2.2. Remove the antenna from the EUT and then connect a low loss RF cable from the antenna port to the spectrum analyzer.

7.2.3. Set center frequency of spectrum analyzer = operating frequency.

7.2.4. Set the spectrum analyzer as RBW=1MHz, VBW=1MHz, Span = 0Hz, Sweep = auto.

7.2.5. Repeat above procedures until all frequencies measured were complete.

7.3. Test Result

Mode	Frequency (MHz)	Pulse Duration (ms)	Dwell Time (ms)	Limit (ms)	Conclusion
GFSK	2441	1.204	105.952	<400	Pass
Note: Dwell time = $88 * 1.204 = 105.952$ ms N=88					

Dwell NVNT user 2441MHz

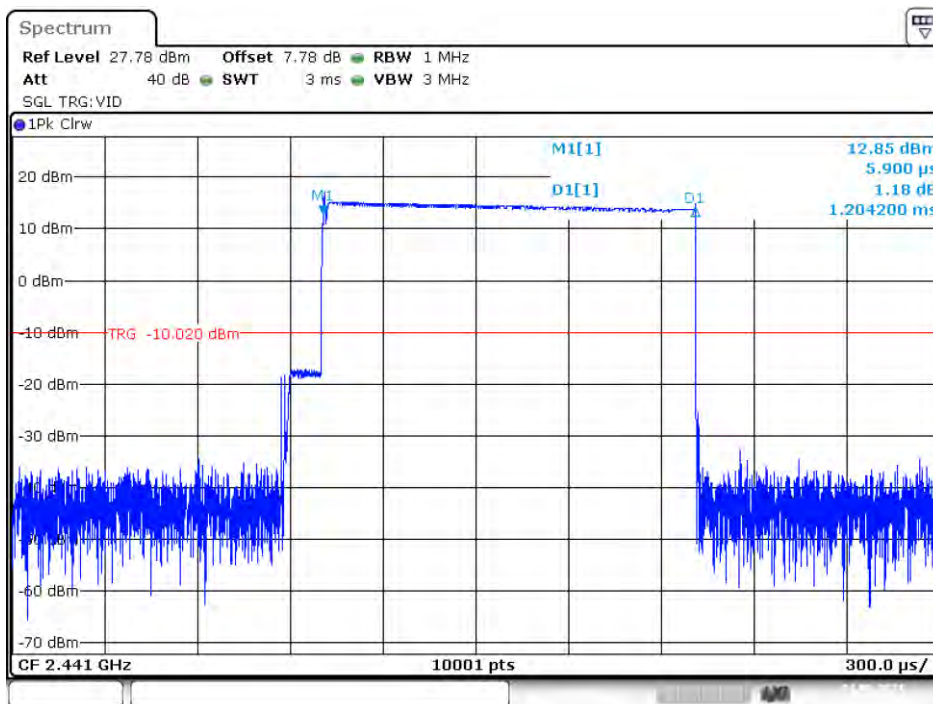

Date: 1 JUN 2021 11:16:19

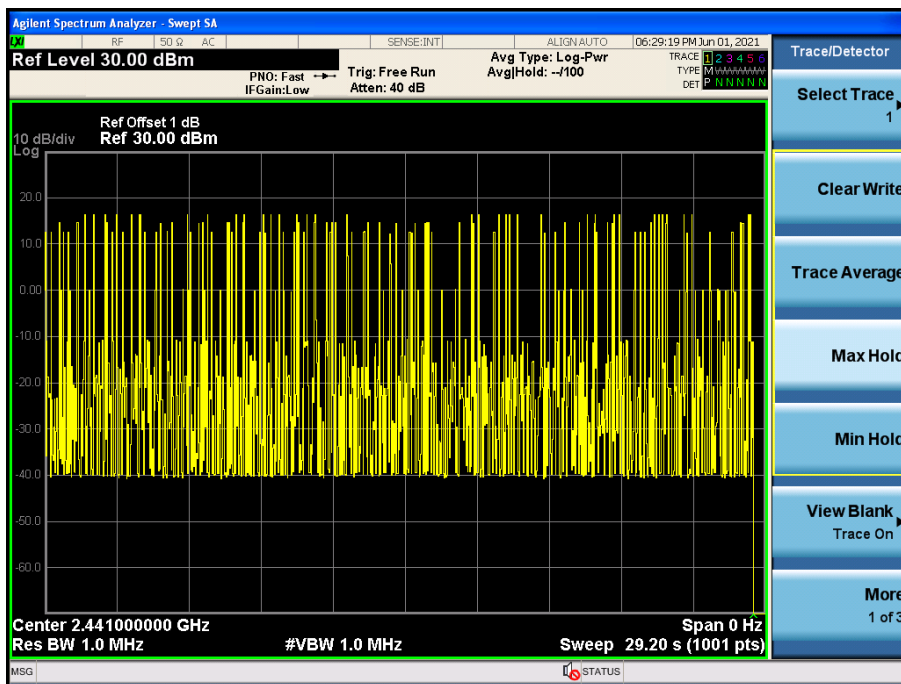

8. RADIATED EMISSIONS

8.1.Limit

All the emissions appearing within 15.205 restricted frequency bands shall not exceed the limits shown in 15.209, all the other emissions shall be at least 20dB below the fundamental emissions, or comply with 15.209 limits.

15.205 Restricted frequency band

MHz	MHz	MHz	GHz
0.090 - 0.110	16.42 - 16.423	399.9 - 410	4.5 - 5.15
0.495 - 0.505	16.69475 - 16.69525	608 - 614	5.35 - 5.46
2.1735 - 2.1905	16.80425 - 16.80475	960 - 1240	7.25 - 7.75
4.125 - 4.128	25.5 - 25.67	1300 - 1427	8.025 - 8.5
4.17725 - 4.17775	37.5 - 38.25	1435 - 1626.5	9.0 - 9.2
4.20725 - 4.20775	73 - 74.6	1645.5 - 1646.5	9.3 - 9.5
6.215 - 6.218	74.8 - 75.2	1660 - 1710	10.6 - 12.7
6.26775 - 6.26825	108 - 121.94	1718.8 - 1722.2	13.25 - 13.4
6.31175 - 6.31225	123 - 138	2200 - 2300	14.47 - 14.5
8.291 - 8.294	149.9 - 150.05	2310 - 2390	15.35 - 16.2
8.362 - 8.366	156.52475 - 156.52525	2483.5 - 2500	17.7 - 21.4
8.37625 - 8.38675	156.7 - 156.9	2690 - 2900	22.01 - 23.12
8.41425 - 8.41475	162.0125 - 167.17	3260 - 3267	23.6 - 24.0
12.29 - 12.293	167.72 - 173.2	3332 - 3339	31.2 - 31.8
12.51975 - 12.52025	240 - 285	3345.8 - 3358	36.43 - 36.5
12.57675 - 12.57725	322 - 335.4	3600 - 4400	(²)

15.209 Limit

FREQUENCY MHz	DISTANCE Meters	FIELD STRENGTHS LIMIT	
		$\mu\text{V}/\text{m}$	$\text{dB}(\mu\text{V})/\text{m}$
0.009-0.490	300	2400/F(KHz)	/
0.490-1.705	30	24000/F(KHz)	/
1.705-30	30	30	29.5
30 ~ 88	3	100	40.0
88 ~ 216	3	150	43.5
216 ~ 960	3	200	46.0
960 ~ 1000	3	500	54.0
Above 1000	3	74.0 $\text{dB}(\mu\text{V})/\text{m}$ (Peak) 54.0 $\text{dB}(\mu\text{V})/\text{m}$ (Average)	

8.2. Block Diagram of Test setup

8.2.1 In 3m Anechoic Chamber Test Setup Diagram for 9KHzHz to 30MHz

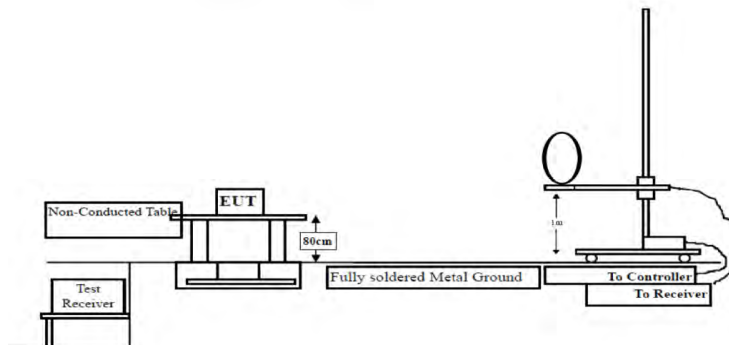

8.2.2 In 3m Anechoic Chamber Test Setup Diagram for 30MHz to 1GHz

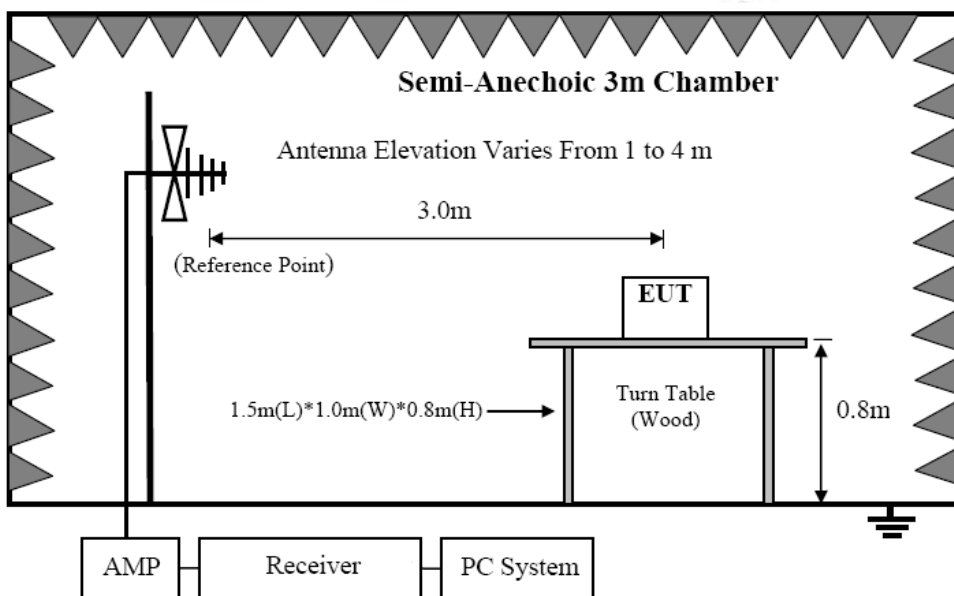

8.2.3 In 3m Anechoic Chamber Test Setup Diagram for frequency above 1GHz

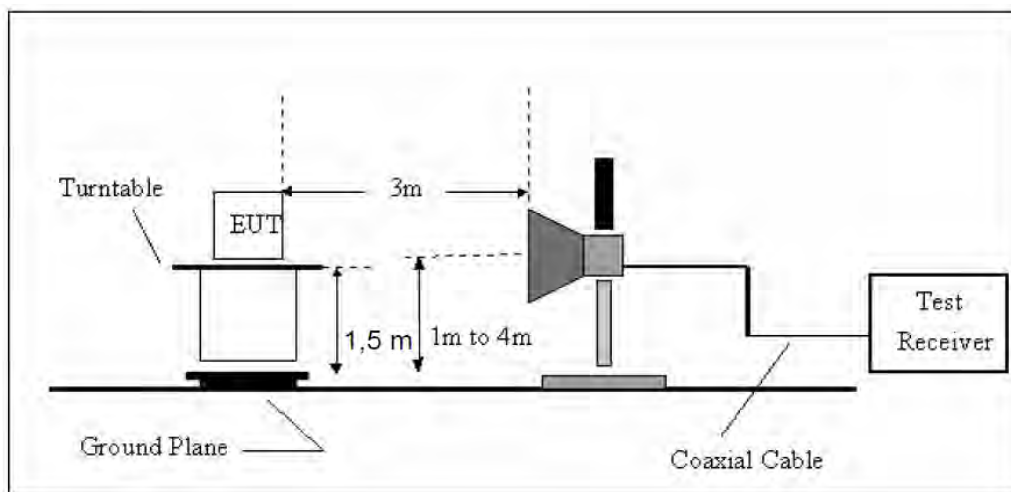

Note: For harmonic emissions test a appropriate high pass filter was inserted in the input port of AMP.

8.3. Test Procedure

- (1) EUT was placed on a non-metallic table, 80 cm above the ground plane inside a semi-anechoic chamber for below 1GHz test, 150 cm above the ground plane inside a semi-anechoic chamber for above 1GHz test
- (2) Setup EUT and simulator as shown in section 1.4 and 6.1
- (3) Test antenna was located 3m from the EUT on an adjustable mast. Below pre-scan procedure was first performed in order to find prominent radiated emissions.
 - (a) Change work frequency or channel of device if practicable.
 - (b) Change modulation type of device if practicable.
 - (c) Rotated EUT though three orthogonal axes to determine the attitude of EUT arrangement produces highest emissions
- (4) Spectrum frequency from 9KHz to 25GHz (tenth harmonic of fundamental frequency) was investigated
- (5) For final emissions measurements at each frequency of interest, the EUT were rotated and the antenna height was varied between 1m and 4m in order to maximize the emission. Measurements in both horizontal and vertical polarities were made and the data was recorded. In order to find the maximum emission, the relative positions of equipments and all of the interface cables were changed according to ANSI C63.10:2013on Radiated Emission test.
- (6) For emissions above 1GHz, both Peak and Average level were measured with Spectrum Analyzer, and the RBW is set at 1MHz, VBW is set at 3MHz for Peak measure; RBW is set at 1MHz, VBW is set at 10Hz for Average measure.

8.4. Test Result

We have scanned the 10th harmonic from 9KHz to the EUT's highest frequency..
Detailed information please see the following page.

From 9KHz to 30MHz: Conclusion: Pass

Note: The amplitude of spurious emissions which are attenuated by more than 20dB below the permissible value has no need to be reported.

From 30MHz to 1000MHz: Conclusion: Pass

Polarization: **Vertical**

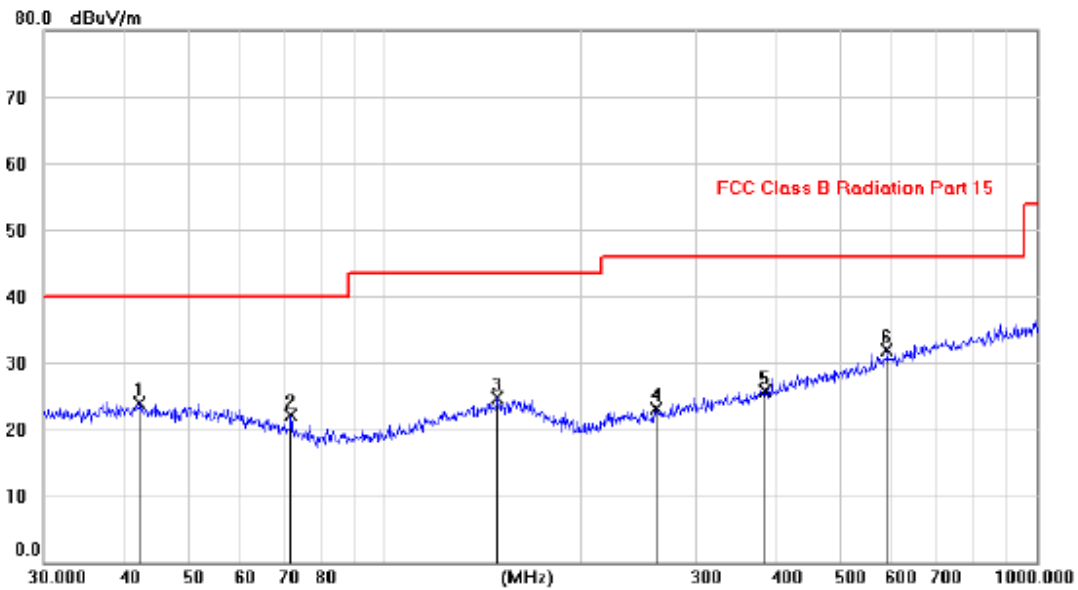

No.	Mk.	Freq.	Reading	Correct	Measure-	Limit	Margin	Antenna	Table		
		MHz	Level	Factor	ment			Height	Degree		
			dBuV	dB	dBuV/m	dBuV/m	dB	Detector	cm	degree	Comment
1		42.2972	9.69	14.31	24.00	40.00	-16.00	peak			
2		71.8656	10.95	11.11	22.06	40.00	-17.94	peak			
3		149.0147	9.65	14.99	24.64	43.50	-18.86	peak			
4		261.8528	10.08	13.03	23.11	46.00	-22.89	peak			
5		383.5281	9.77	15.98	25.75	46.00	-20.25	peak			
6	*	590.9047	11.95	20.04	31.99	46.00	-14.01	peak			

Note: 1. *:Maximum data; x:Over limit; !:over margin.

2.Measurement=Reading Level+Correct Factor; Correct Factor=Antenna Factor+Cable Loss.

Polarization: *Horizontal*

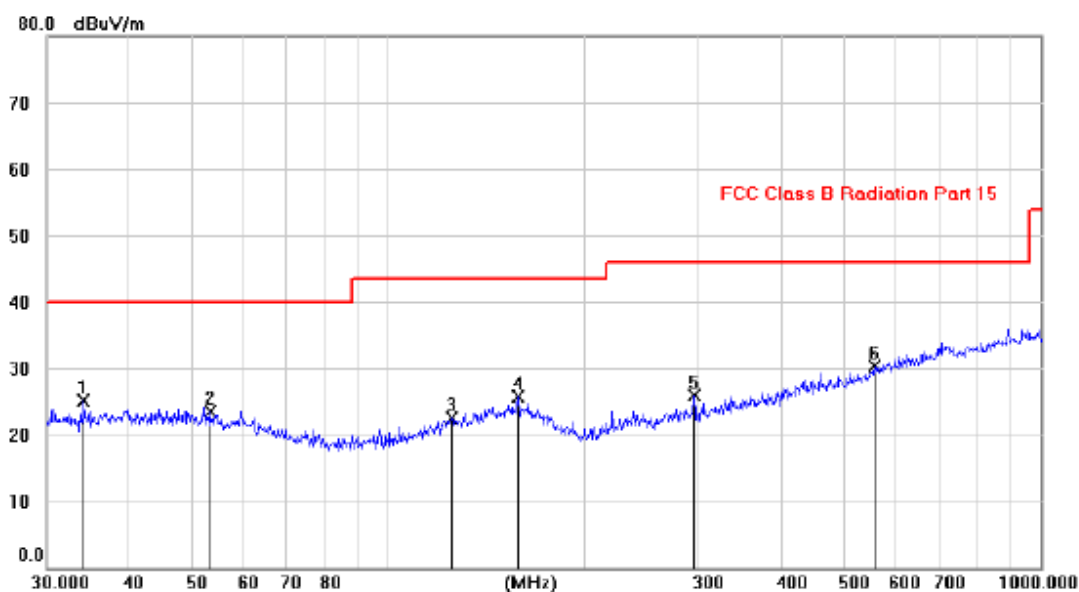

No.	Mk.	Freq. MHz	Reading Level dBuV	Correct Factor dB	Measure- ment dBuV/m	Limit dBuV/m	Margin dB	Antenna Height cm	Table Degree degree	Comment
1	*	34.2280	11.40	13.71	25.11	40.00	-14.89	peak		
2		53.4802	9.74	13.72	23.46	40.00	-16.54	peak		
3		125.3138	9.26	13.33	22.59	43.50	-20.91	peak		
4		158.2603	10.62	15.04	25.66	43.50	-17.84	peak		
5		294.6986	11.88	13.98	25.86	46.00	-20.14	peak		
6		555.0848	10.99	19.28	30.27	46.00	-15.73	peak		

Note: 1. *:Maximum data; x:Over limit; !:over margin.

2.Measurement=Reading Level+Correct Factor; Correct Factor=Antenna Factor+Cable Loss.

Remark: All modes have been tested, and only worst data of GFSK Channel High mode was listed in this report.

From 1G-25GHz

Test Mode: GFSK TX Low									
Freq (MHz)	Read Level (dBuV/m)	Polar (H/V)	Antenna Factor (dB/m)	Cable loss(dB)	Amp Factor (dB)	Result (dBuV/m)	Limit (dBuV/m)	Margin (dB)	Remark
4810	45.83	V	33.98	10.22	34.25	55.78	74	18.22	PK
4810	35.73	V	33.98	10.22	34.25	45.68	54	8.32	AV
7215	/	/	/	/	/	/	/	/	/
9620	/	/	/	/	/	/	/	/	/
4810	45.92	H	33.98	10.22	34.25	55.87	74	18.13	PK
4810	34.53	H	33.98	10.22	34.25	44.48	54	9.52	AV
7215	/	/	/	/	/	/	/	/	/
9620	/	/	/	/	/	/	/	/	/
Test Mode: GFSK TX Mid									
4882	46.58	V	33.98	10.22	34.25	56.53	74	17.47	PK
4882	35.89	V	33.98	10.22	34.25	45.84	54	8.16	AV
7323	/	/	/	/	/	/	/	/	/
9764	/	/	/	/	/	/	/	/	/
4882	46.68	H	33.98	10.22	34.25	56.63	74	17.37	PK
4882	34.83	H	33.98	10.22	34.25	44.78	54	9.22	AV
7323	/	/	/	/	/	/	/	/	/
9764	/	/	/	/	/	/	/	/	/
Test Mode: GFSK TX High									
4956	46.28	V	33.98	10.22	34.25	56.23	74	17.77	PK
4956	35.27	V	33.98	10.22	34.25	45.22	54	8.78	AV
7434	/	/	/	/	/	/	/	/	/
9912	/	/	/	/	/	/	/	/	/
4956	46.67	H	33.98	10.22	34.25	56.62	74	17.38	PK
4956	35.15	H	33.98	10.22	34.25	45.10	54	8.90	AV
7434	/	/	/	/	/	/	/	/	/
9912	/	/	/	/	/	/	/	/	/
Note:									
1, Result = Read level + Antenna factor + cable loss-Amp factor									
2, All the other emissions not reported were too low to read and deemed to comply with FCC limit.									

Conducted RF Spurious Emission

Condition	Mode	Frequency (MHz)	Antenna	Max Value (dBc)	Limit (dBc)	Verdict
NVNT	user	2405	Ant 1	-35.7710029602	-20	Pass
NVNT	user	2441	Ant 1	-65.1772436523	-20	Pass
NVNT	user	2478	Ant 1	-41.3278052902	-20	Pass

Tx. Spurious NVNT user 2405MHz Ant1 Emission

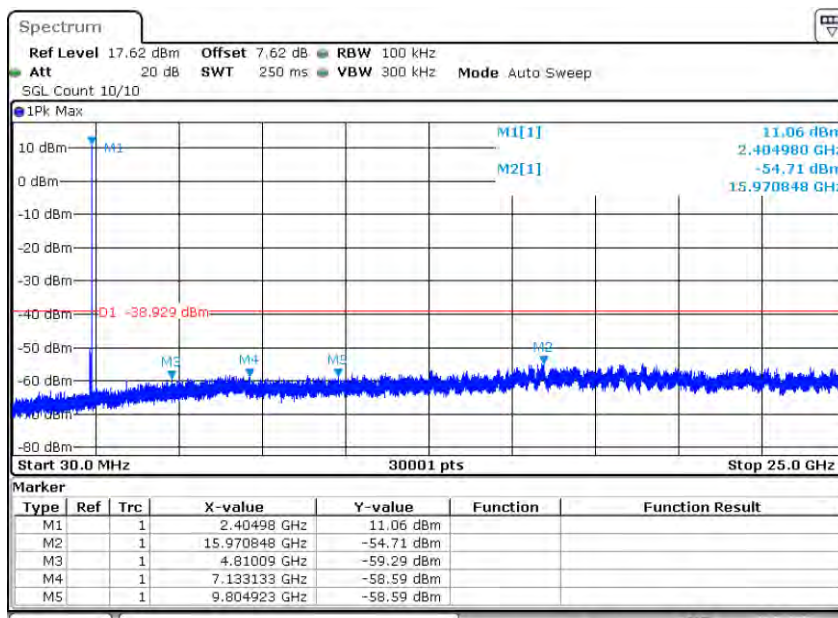

Date: 1.JUN.2021 11:29:06

Tx. Spurious NVNT user 2441MHz Ant1 Emission

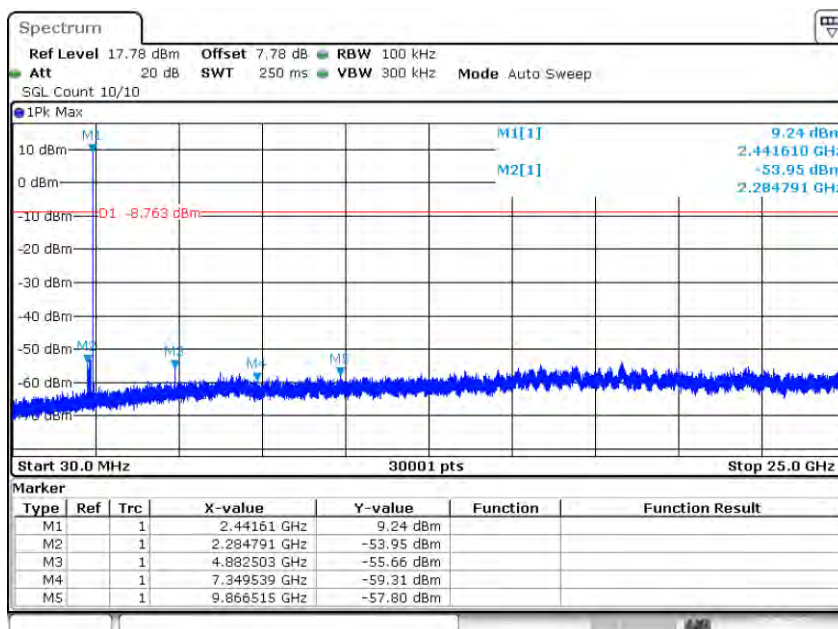

Date: 1.JUN.2021 11:39:32

Tx. Spurious NVNT user 2478MHz Ant1 Emission

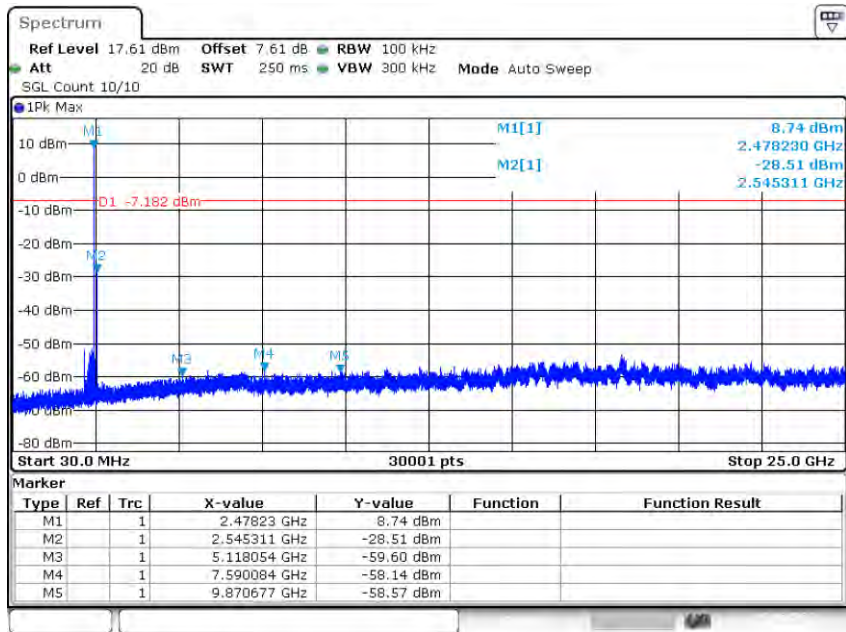

Date: 1 JUN 2021 12:09:13

9. BAND EDGE COMPLIANCE

9.1. Block Diagram of Test Setup

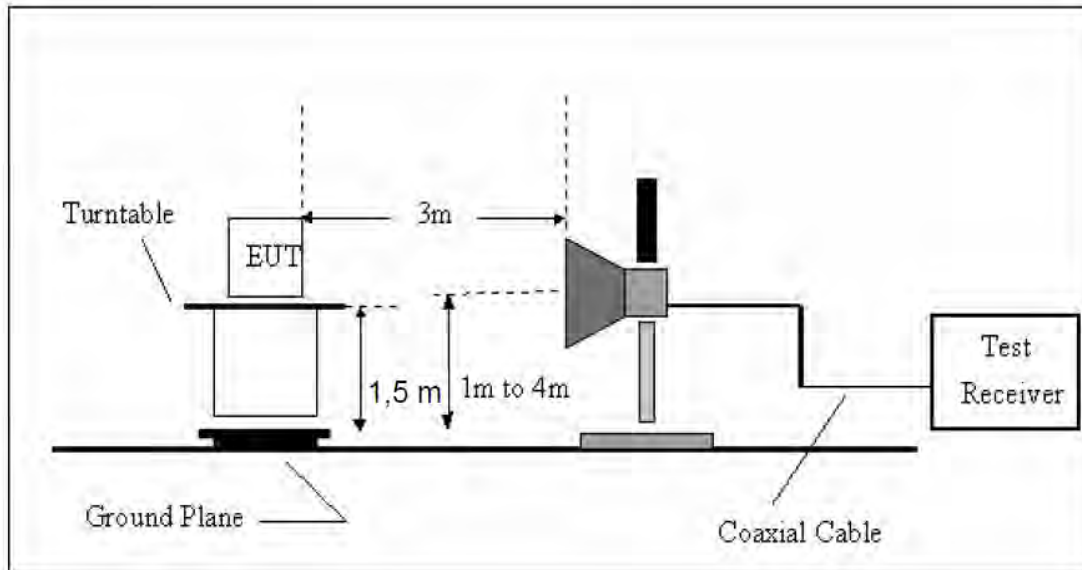

9.2. Limit

All the lower and upper band-edges emissions appearing within restricted frequency bands shall not exceed the limits shown in 15.209, all the other emissions outside operation shall be at least 20dB below the fundamental emissions, or comply with 15.209 limits.

9.3. Test Procedure

All restriction band and non- restriction band have been tested , only worse case is reported.

9.4. Test Result

Pass. (See below detailed test data)

No-hopping
CH-L

Horizontally

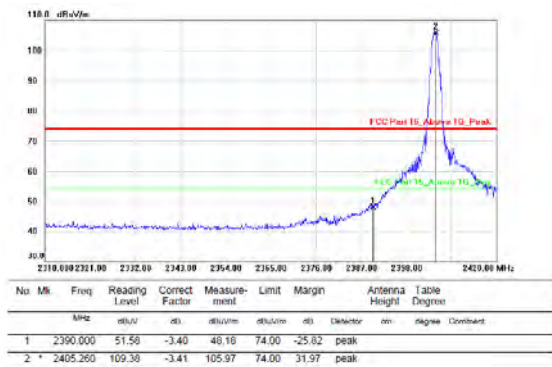

Vertically

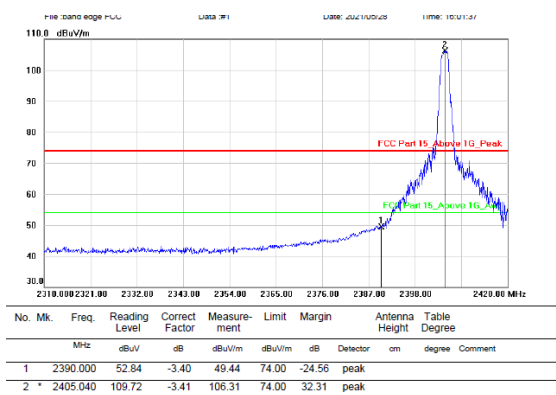

CH-H

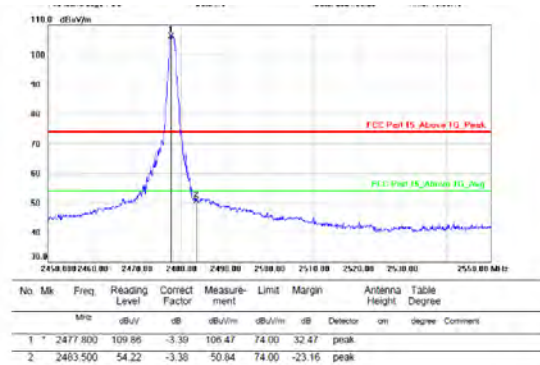
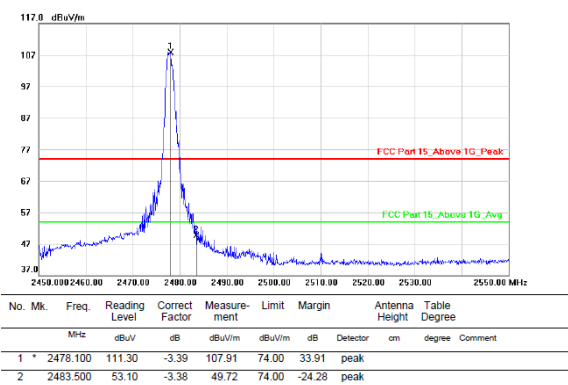

Hopping
CH-L

Horizontally

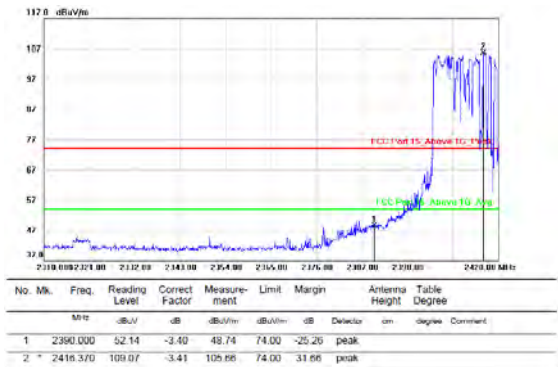

Vertically

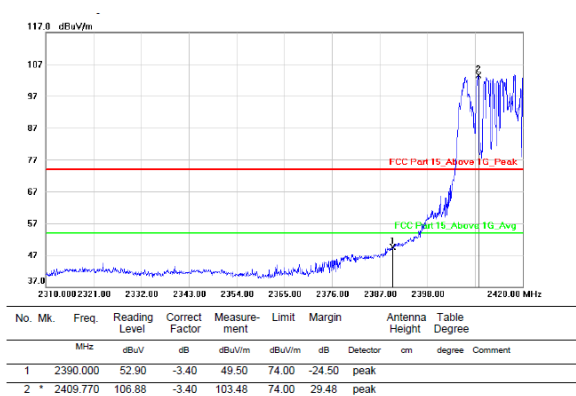

CH-H

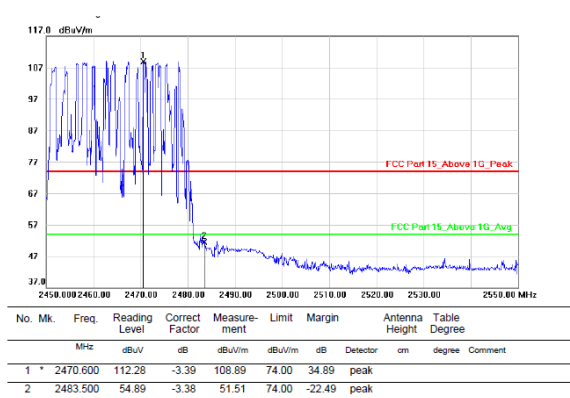
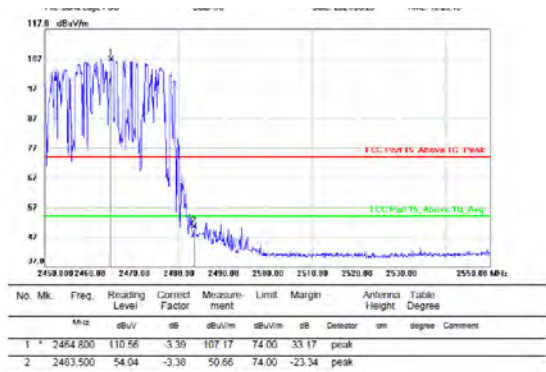

No-hopping

CH-L

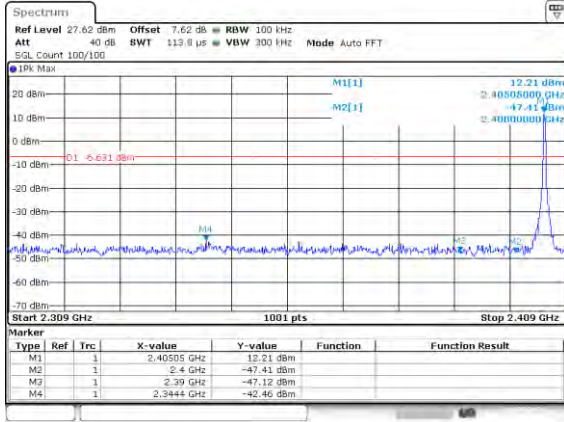

CH-H

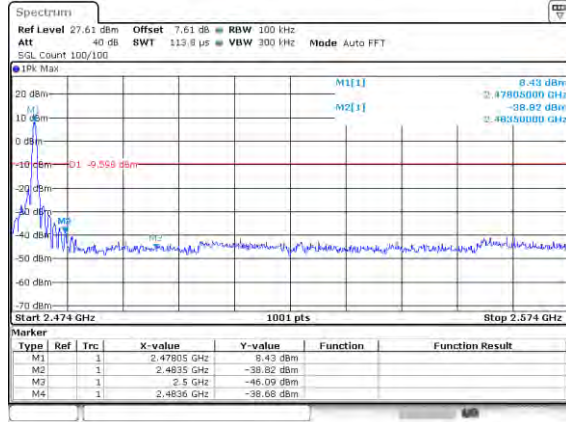

Hopping

CH-L

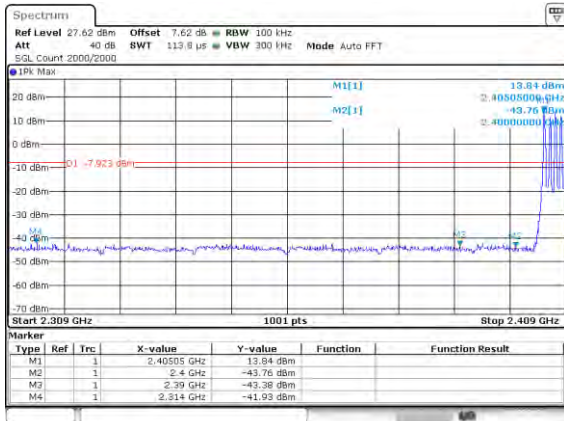

CH-H

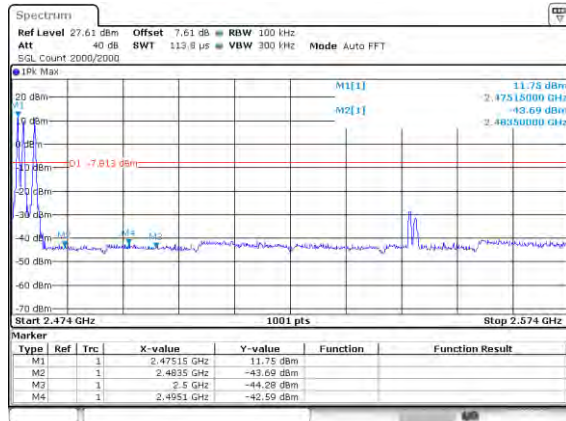

10. POWER LINE CONDUCTED EMISSIONS

10.1. Block Diagram of Test Setup

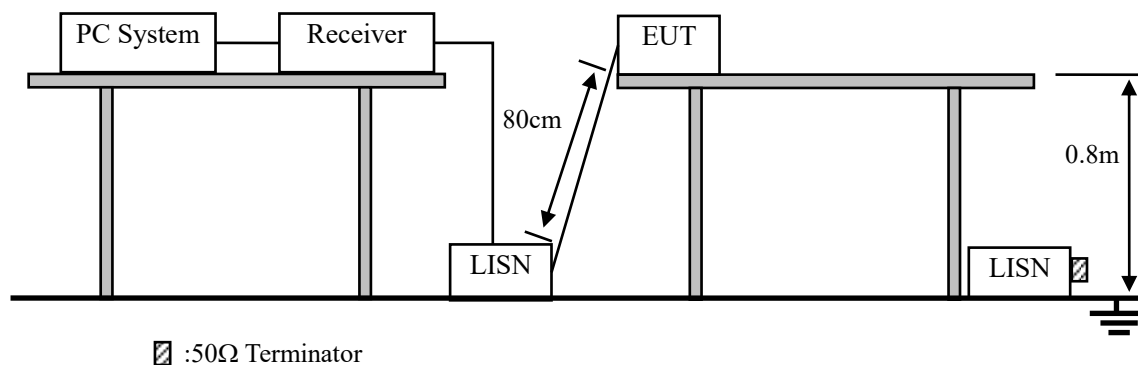

10.2. Limit

Frequency	Maximum RF Line Voltage	
	Quasi-Peak Level dB(μ V)	Average Level dB(μ V)
150kHz ~ 500kHz	66 ~ 56*	56 ~ 46*
500kHz ~ 5MHz	56	46
5MHz ~ 30MHz	60	50

Notes: 1. * Decreasing linearly with logarithm of frequency.

2. The lower limit shall apply at the transition frequencies.

10.3. Test Procedure

- (1) The EUT was placed on a non-metallic table, 80cm above the ground plane.
- (2) Setup the EUT and simulator as shown in 10.1
- (3) The EUT Power connected to the power mains through a power adapter and a line impedance stabilization network (L.I.S.N1). The other peripheral devices power cord connected to the power mains through a line impedance stabilization network (L.I.S.N2), this provided a 50-ohm coupling impedance for the EUT (Please refer to the block diagram of the test setup and photographs). Both sides of power line were checked for maximum conducted interference. In order to find the maximum emission, the relative positions of equipments and all of the interface cables were changed according to ANSI C63.10 :2013on conducted Emission test.
- (4) The bandwidth of test receiver is set at 10KHz.
- (5) The frequency range from 150 KHz to 30MHz is checked.

10.4. Test Result

The EUT is supplied by battery only, so this item does not applicable.

11. ANTENNA REQUIREMENTS

11.1. Limit

For intentional device, according to FCC 47 CFR Section 15.203, an intentional radiator shall be designed to ensure that no antenna other than that furnished by the responsible party shall be used with the device. And according to FCC 47 CFR Section 15.247 (b), if transmitting antennas of directional gain greater than 6dBi are used, the power shall be reduced by the amount in dB that the directional gain of the antenna exceeds 6dBi.

11.2. Result

The EUT antenna is integrated Antenna. It complies with the standard requirement.

12. TEST SETUP PHOTO

12.1. Photos of Radiated emission

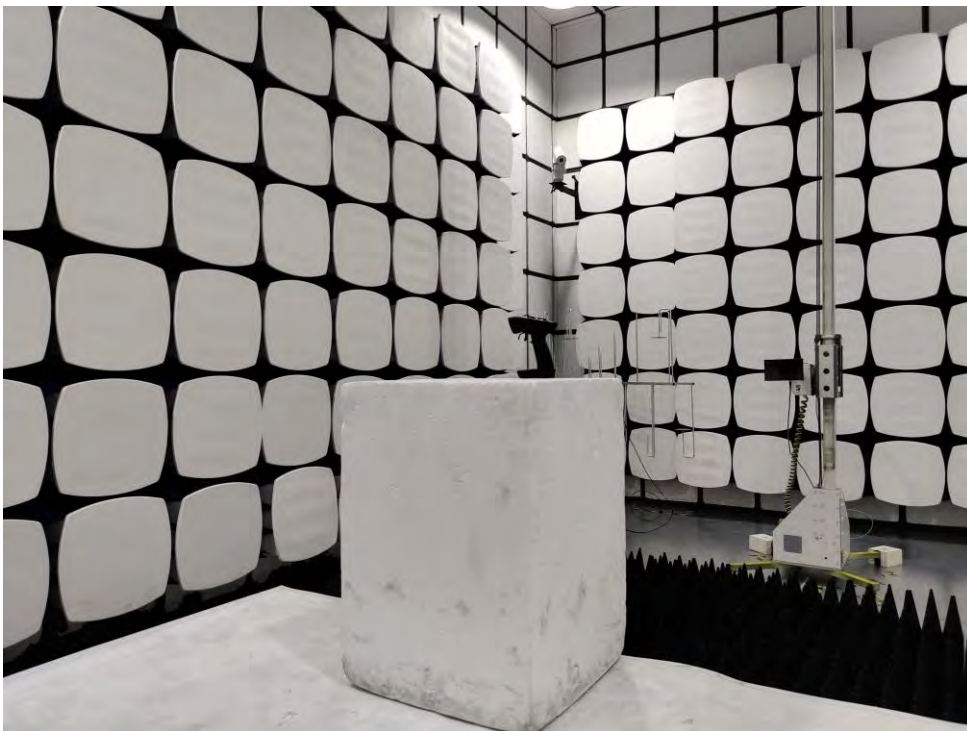
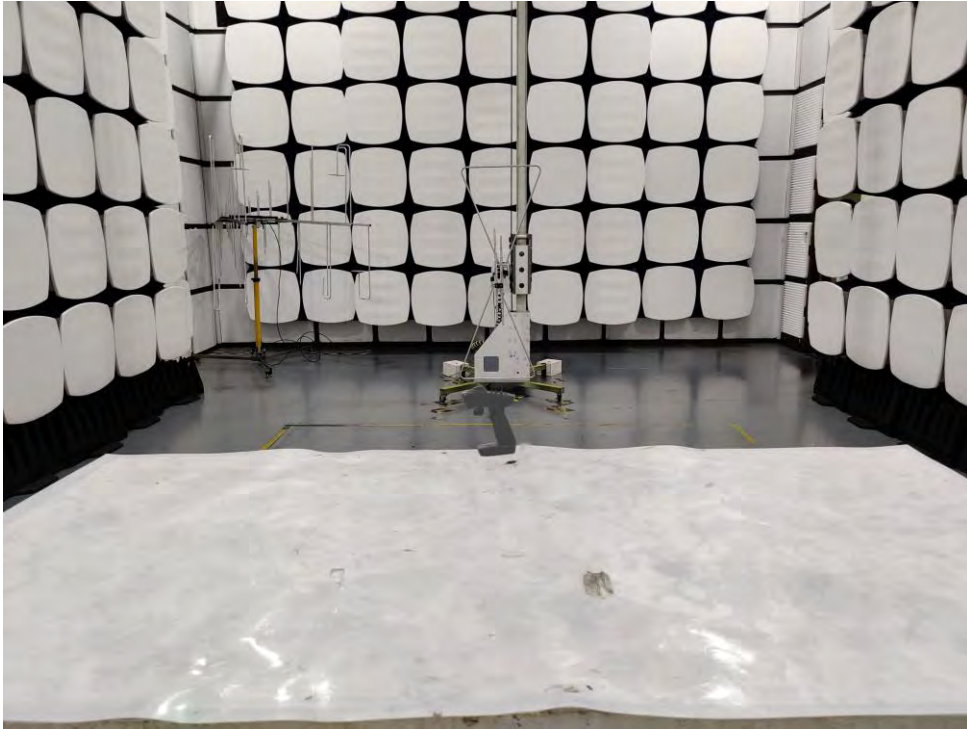

13. PHOTOS OF EUT







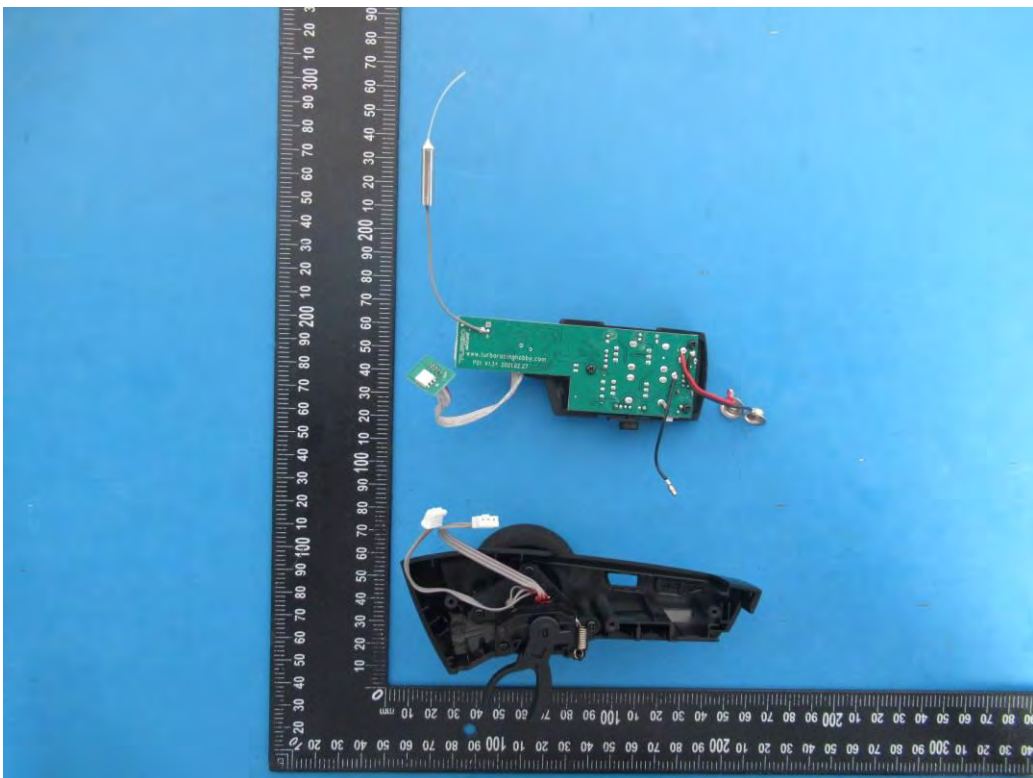

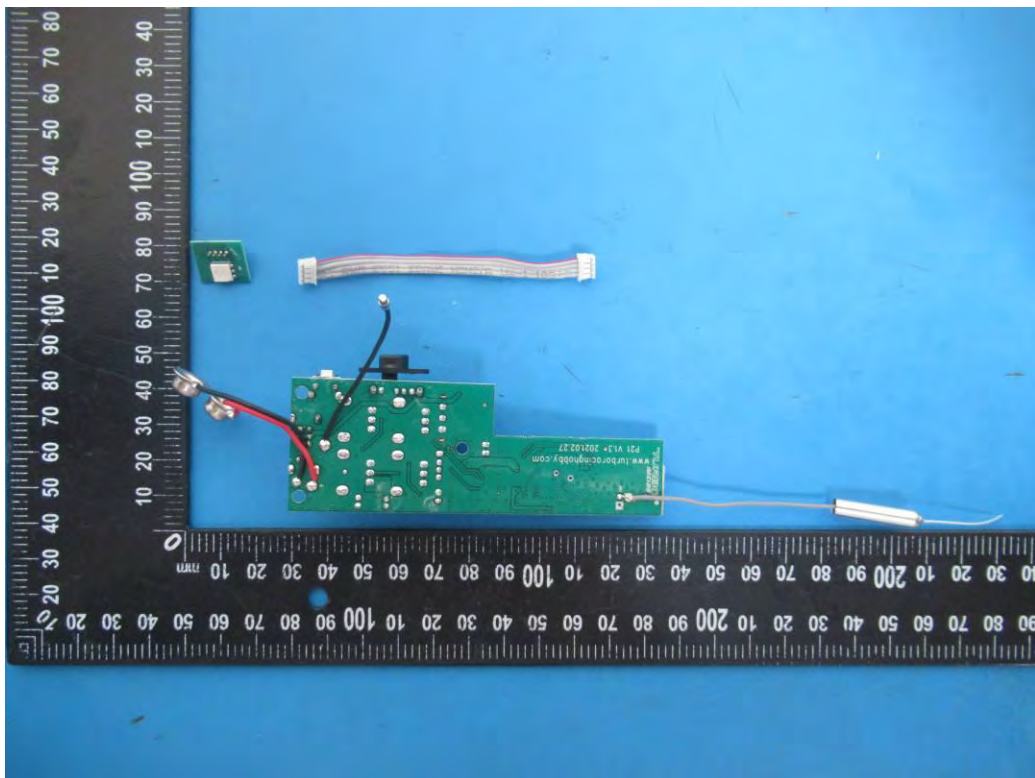
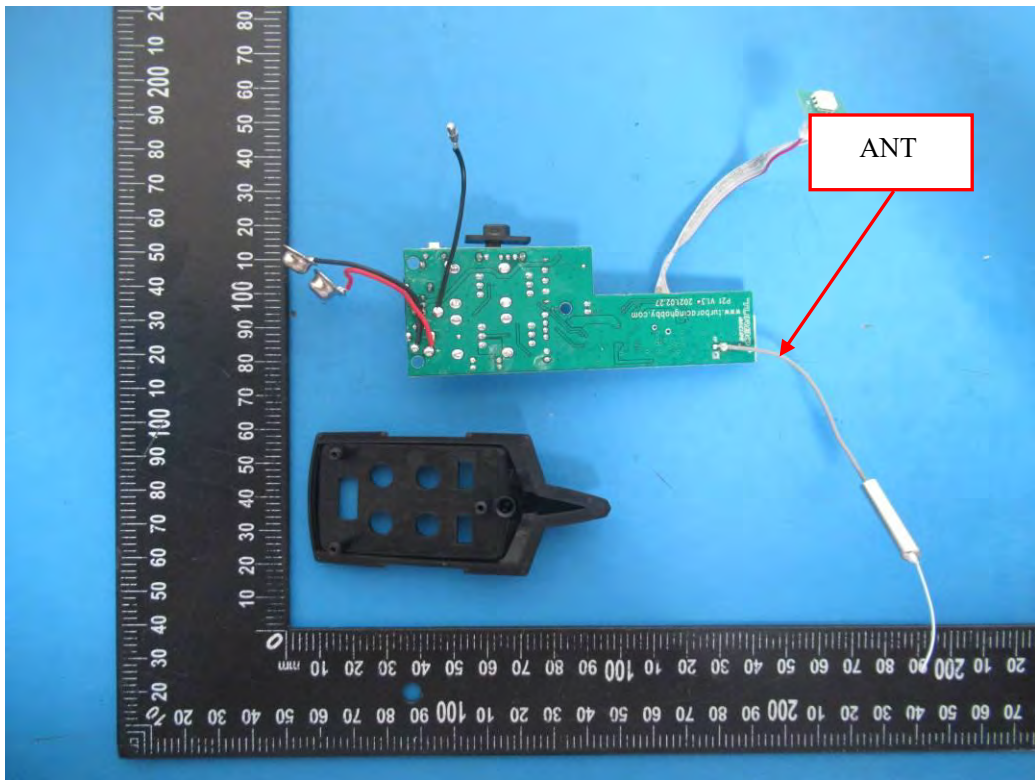

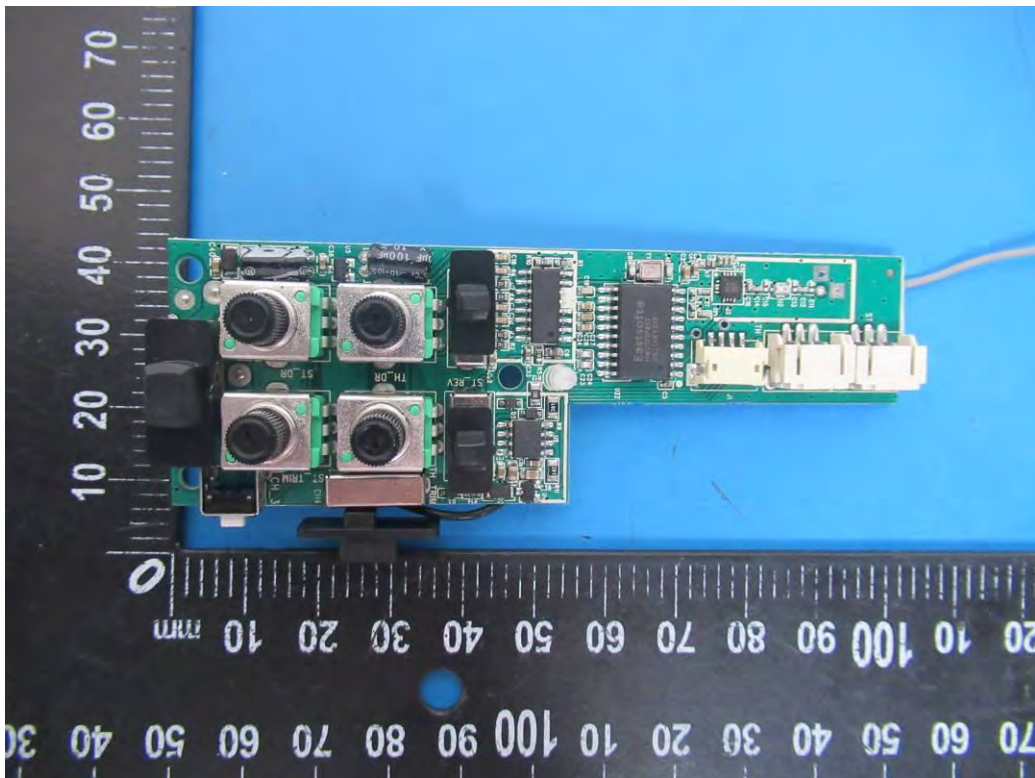
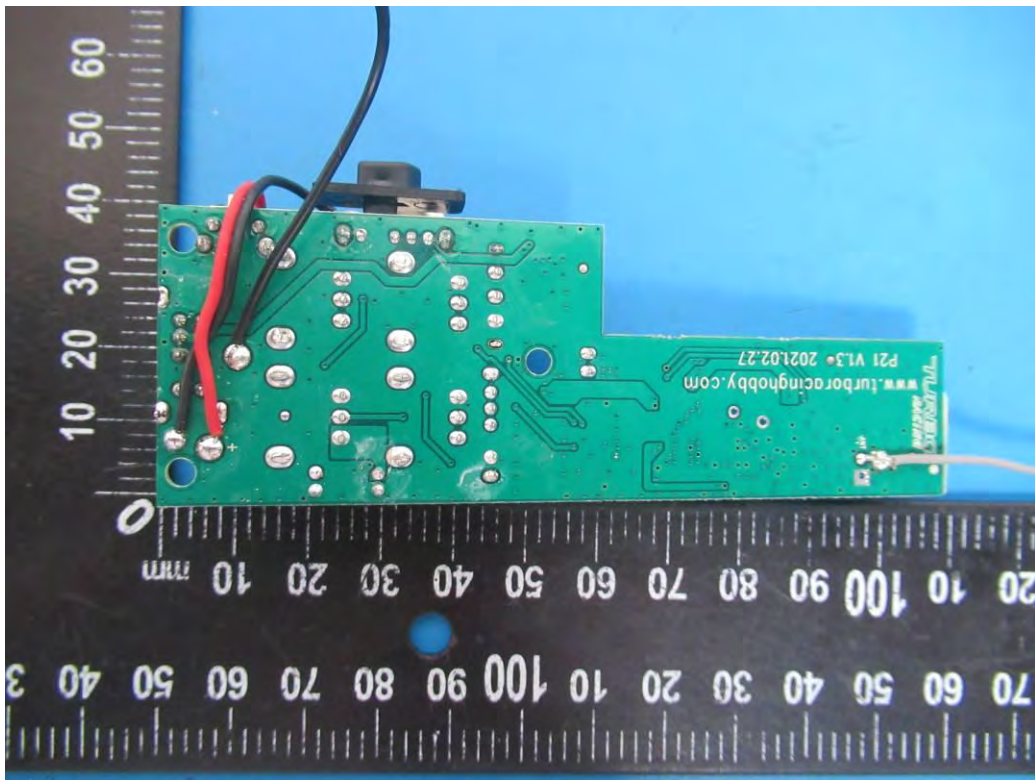

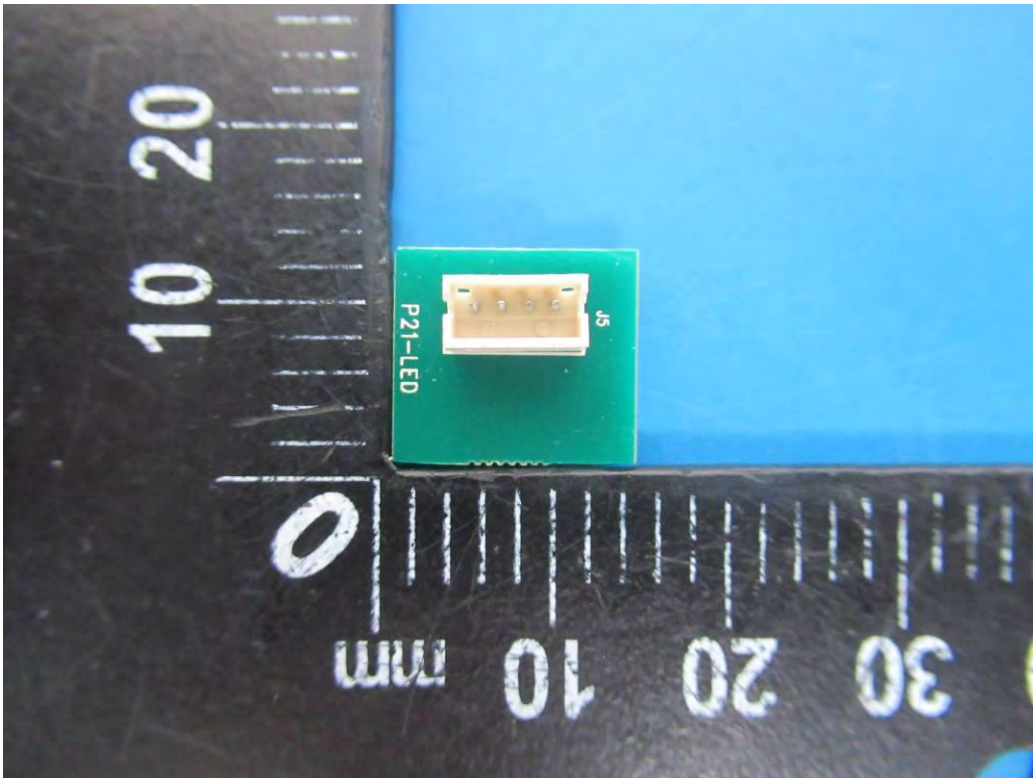
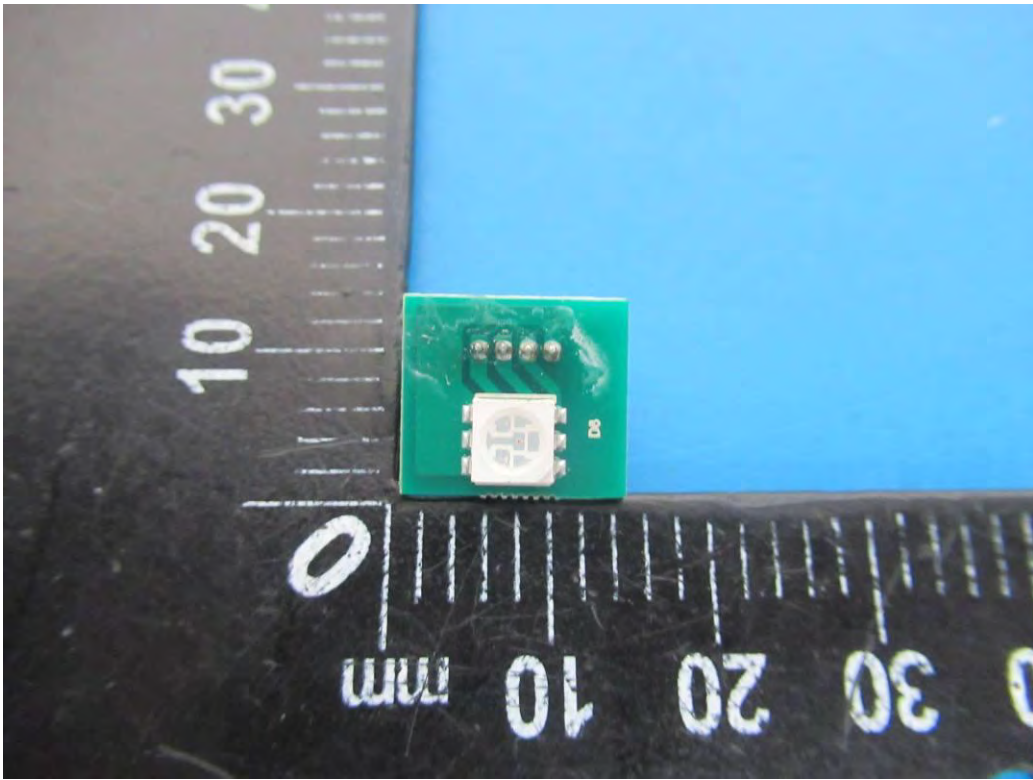



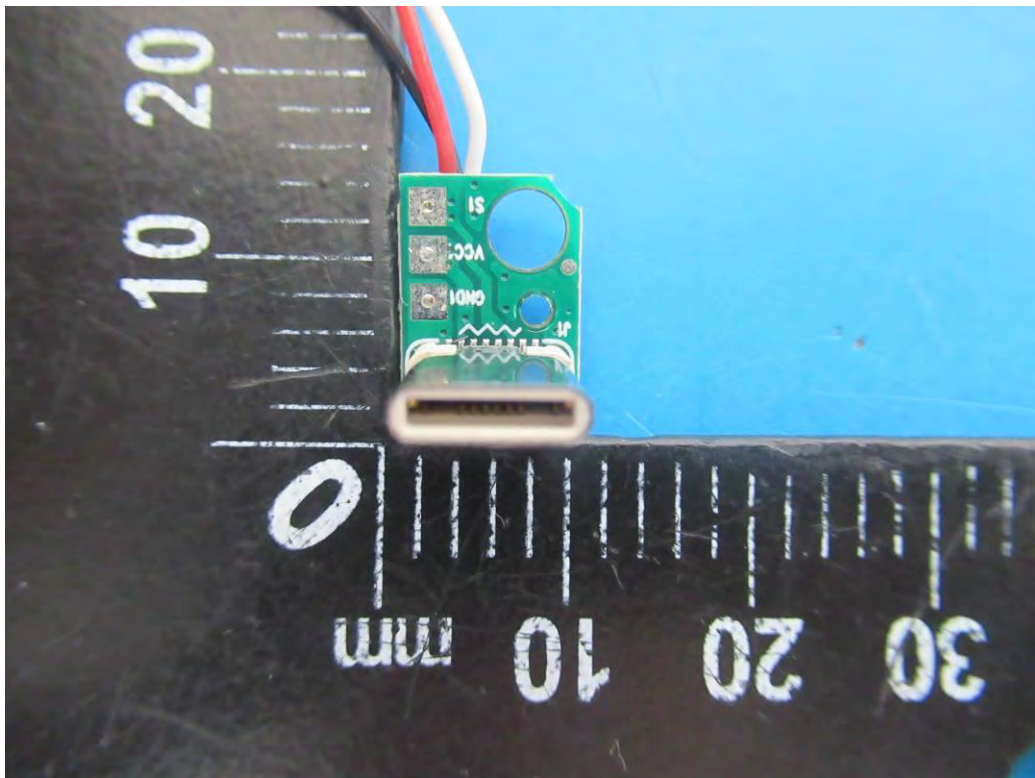
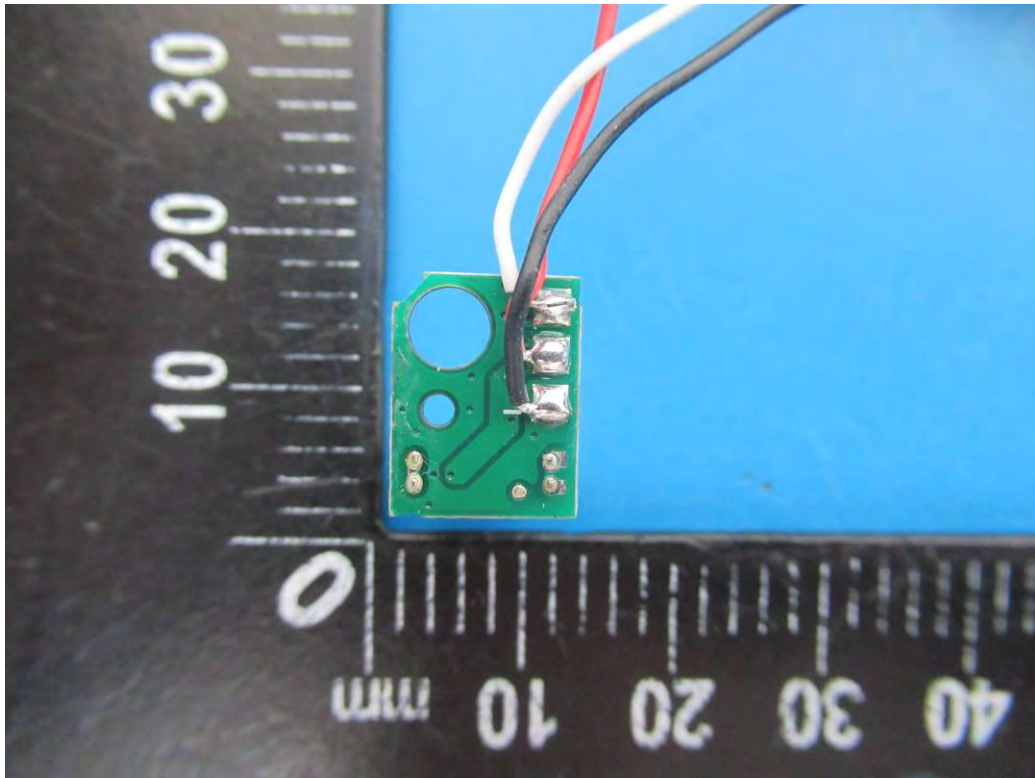

-----THE END OF REPORT-----