

Testing Report

Customer Name: Ningbo Qinghe Electronics Co., Ltd

Product Name: 2.4G Antenna

Sample Model: QHL020_2.4G-7.5-10.8

Reference Standard: *GB/T 9410-2008; ANSI/IEEE Std149-1979*

Issue Date: 2023.04.18

Engineer: Zkmis	Date: 2023.4.17
Auditor: Eason	Date: 2023.4.18
Approver: Janson	Date: 2023.4.18

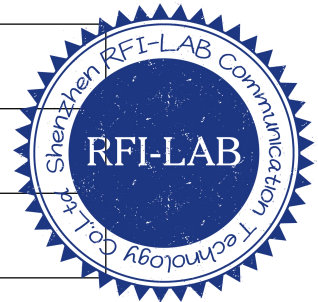

Version

Version No.	Date	Description	Formulate	Approval
A0	2023.04.18	For the first time, formulate	Zkris	Eason

Contents

1.General Information	3
1.1 General information of testing institutions	3
1.2 Testing principle	3
1.3 Test equipment	4
1.4 Test environment	4
1.5 Statement	4
2.Sample Information	5
2.1 Client information	5
2.2 Description of EUT(S)	5
2.3 EUT appearance	6
2.4 EUT setup photo of free space OTA testing	6
3. Test Results	7
3.1 Test standard	7
3.2 Test uncertainty	7
3.3 Test data	8
3.3.1 VSWR parameters	8
3.3.2 VSWR data	8
3.3.3 Typical free space efficiency and gain	8
3.3.4 Typical free space radiation pattern	9
(The following is blank)	10

1. General Information

1.1 General information of testing institutions

Name	Shenzhen RFI-LAB Communication Technology Co., Ltd.
Address	10/F A, Lingyun Bld, Liufang Rd, Baoan District, SZ
Tel	13682621346
E-mail	rfi-lab@tech-now.com
Equipment	All the equipment used in the report is fixed in Zone B, West Side of 1/F, Building 1, Tingwei Industrial Park, No.6 Liufang Road, Bao 'an District, Shenzhen

1.2 Testing principle

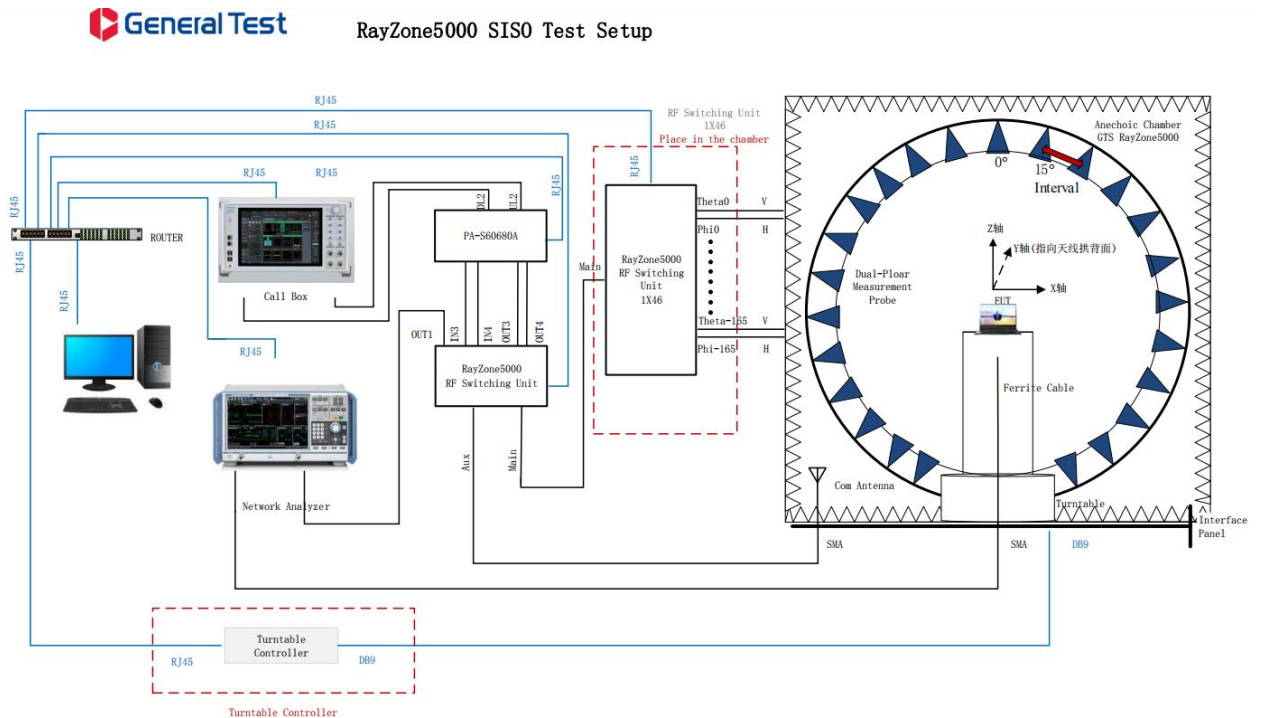

1.3 Test equipment

Equipment	Model No.	Serial No.	Manufacturer	Calibration date	Next calibration date
OTA Test System	RayZone-5000	RFI-LAB-RF-D00	GTS	2023.3.14	2025.3.13
Network Analyzer	E5071C	RFI-LAB-RF-D01	KEYSIGHT	2022.5.13	2023.5.12

1.4 Test environment

Temperature	22.8°C
Humidity	58%RH
Pressure	100.35kPa

1.5 Statement

- (1) The test results in the report are only applicable to the tested samples and the tested samples work under the environment described in the report.
- (2) Only Shenzhen RFI-LAB Communication Technology Co., Ltd. have the right to modify the report, and the modification information shall be annotated in the revision form.
- (3) Any objection to this report shall be raised within 30 days after formal confirmation of the report.
- (4) This report is invalid if there is any evidence that the sample information provided is falsified.
- (5) The report is invalid without the signature of the auditor and approver.

2. Sample Information

2.1 Client information

Name	Ningbo Qinghe Electronics Co., Ltd
Address	Gao Qiao Zhen Song Jia Cao Cun, Haishu District, Ningbo City, Zhejiang
Contacts	/
Tel	/
E-mail	/
Manufacturer	/

2.2 Description of EUT(S)

Product Name	2.4G Antenna
Sample Model	QHL020_2.4G-7.5-10.8
Antenna Size	/
Serial No.	/
Antenna Type	PCB Antenna
Test Item	VSWR;Antenna gain; Efficiency; Radiation pattern
Frequency Range	2400-2500MHz
Received Date	2023.04.17
Test Date	2023.04.17
Remark	The length of the RF cable is 50mm

2.3 EUT appearance

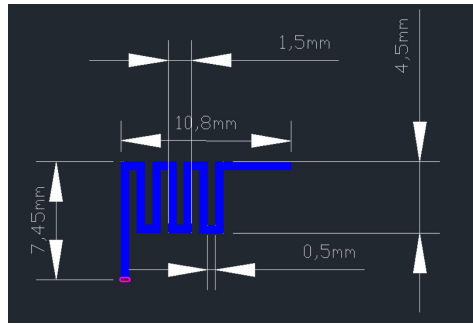
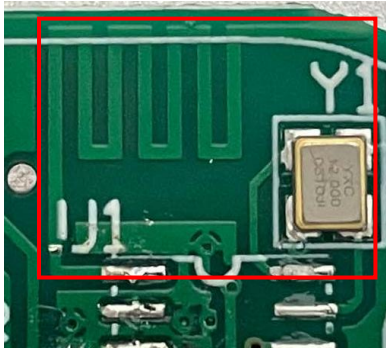

2.4 EUT setup photo of free space OTA testing

Planform

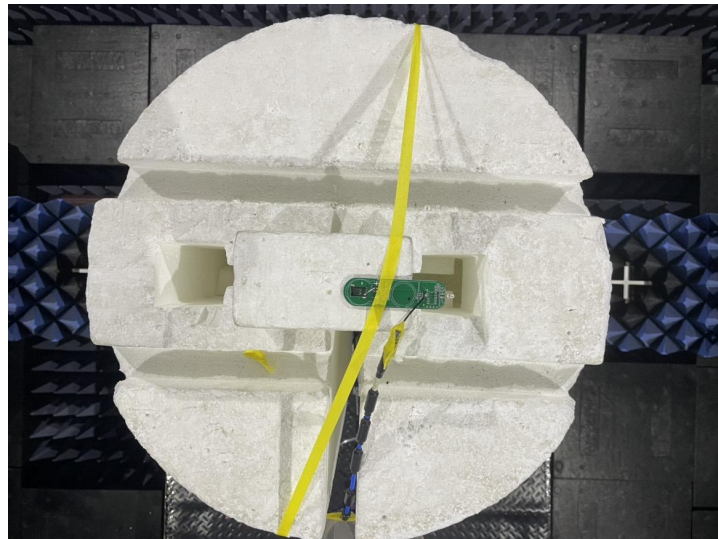

Front view

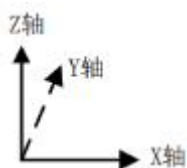
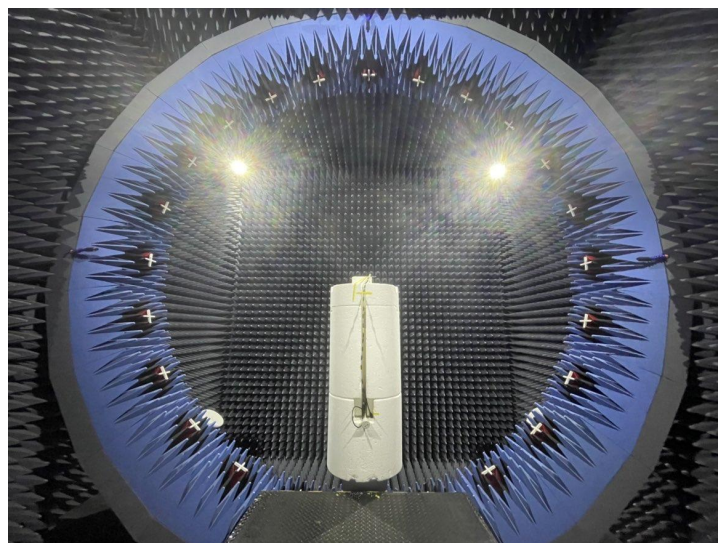

3. Test Results

3.1 Test standard

Name	Parameter	Method	Standard no.
Mobile communication antenna	Antenna gain	Generic specification for antennas used in the mobile communications	GB/T 9410-2008
	Radiation pattern		
	VSWR		
Antenna	Radiation efficiency	IEEE Standard Test Procedures for Antennas	ANSI/IEEE Std 149-1979
	Gain and directivity		

3.2 Test uncertainty

The uncertainty was calculated on the basis of the GUM published by ISO, using the inclusion factor of $K=2$ and the 95% confidence level to express the extended uncertainty.

Item	Uncertainty
VSWR	± 0.3
Antenna gain	$\pm 1\text{dB}$
Radiation efficiency	$\pm 10\%$

3.3 Test data

3.3.1 VSWR parameters

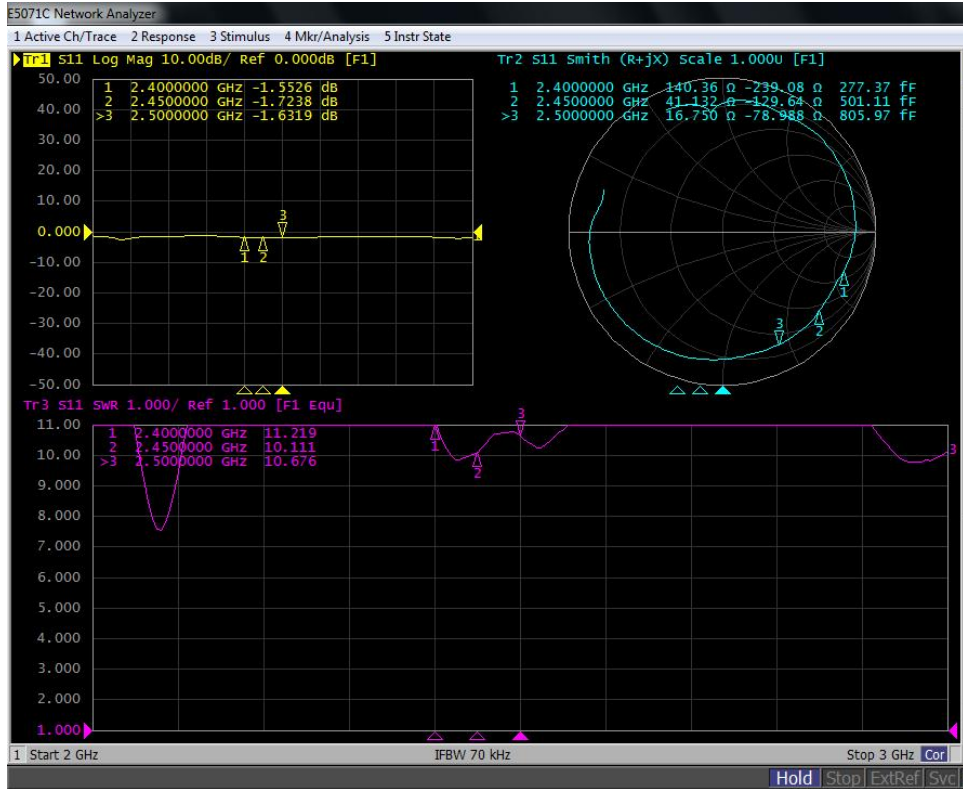

3.3.2 VSWR data

Frequency/MHz	2400	2450	2500
VSWR	11.219	10.111	10.676

3.3.3 Typical free space efficiency and gain

Frequency/MHz	2400	2410	2420	2430	2440	2450	2460	2470	2480	2490	2500
Peak Gain/dBi	-8.73	-8.24	-8.15	-8.11	-8.35	-9.27	-9.34	-9.15	-9.38	-9.42	-9.38
Efficiency/%	3.90	4.49	4.83	5.12	4.94	4.42	4.23	4.08	3.75	3.67	3.82

3.3.4 Typical free space radiation pattern

(1) X-Z Plane(unit: dBi):

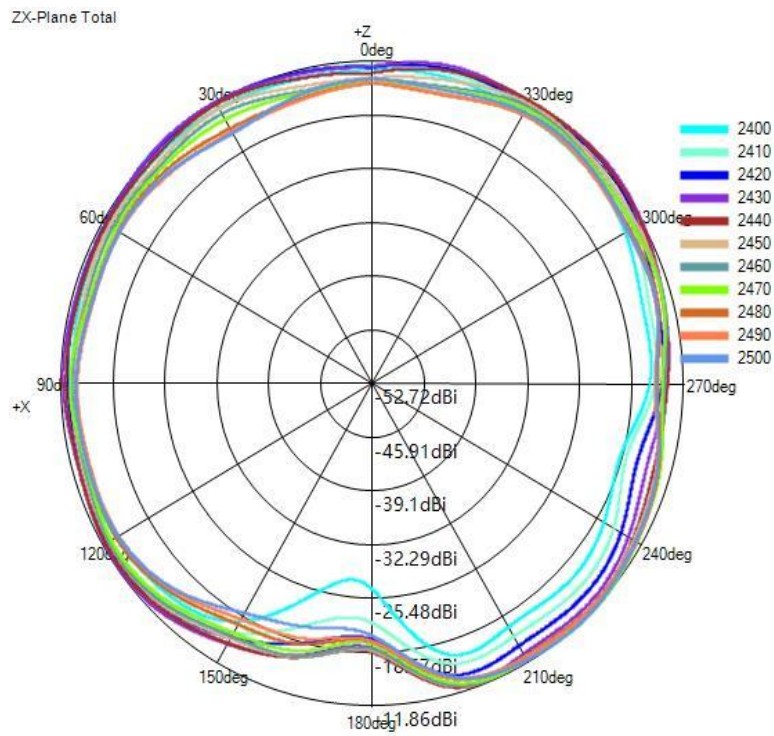

(2) Y-Z Plane(unit: dBi):

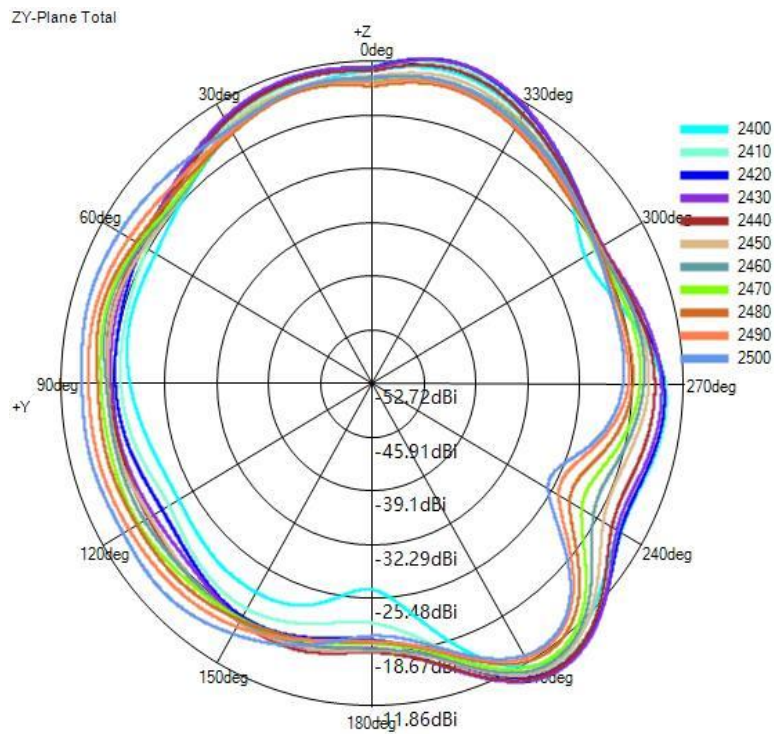

(3) X-Y Plane(unit: dBi):

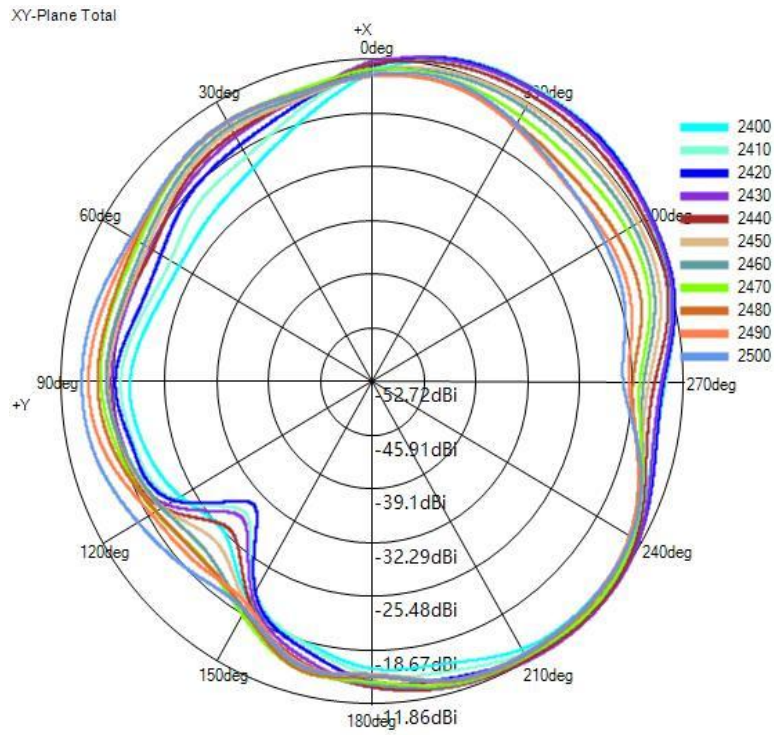

(4) Typical Free Space 3D Radiation Pattern at 2.43GHz(unit: dBi):

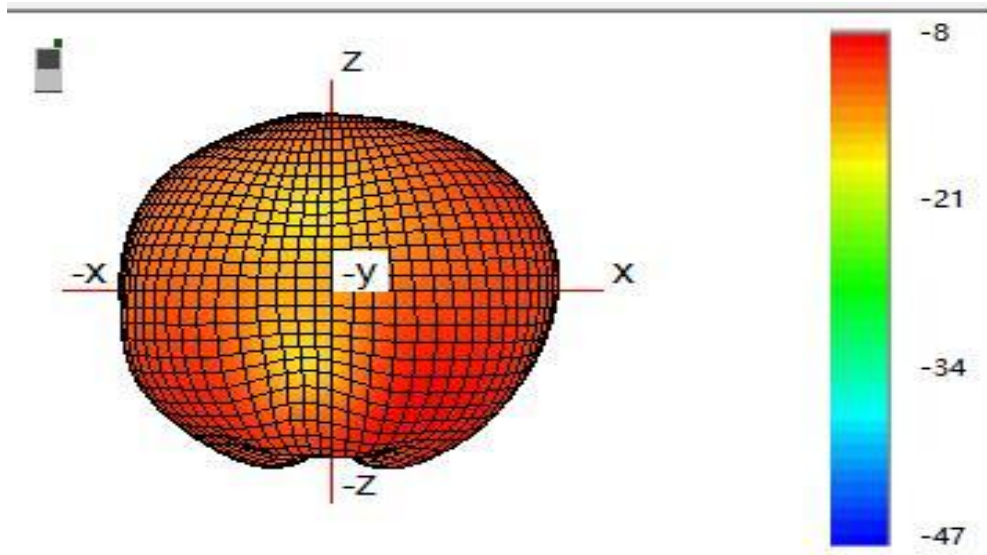

 End

(The following is blank)