

FCC RADIO TEST REPORT

FCC ID: 2ARCP-WP-10

Sample : Wireless System

Trade Name : M-VAVE

Main Model : WP-10

Additional Model :

WP-1, WP-2, WP-3, WP-4, WP-5, WP-6,
WP-7, WP-8, WP-9, WP-11, WP-12,
GWM-11, LEM-01, WAVE AIR 2 GWM-12,
SWS1, SWS2, SWS3, SWS4, SWS5,
SWS6, SWS7, SWS8, SWS9, SWS10,
SWS11, SWS12

Report No. : UNIA22061726ER-61

Prepared for

Sinco Intelligent Technology Co., Ltd.

Workshop D-2, Assembly Workshop, North Airport Road, Hongqi Town,
Jinwan District, Zhuhai, China

Prepared by

Shenzhen United Testing Technology Co., Ltd.

2F, Annex Bldg, Jiahuangyuan Tech Park, #365 Baotian 1 Rd, Tiegang
Community, Xixiang Str, Bao'an District, Shenzhen, China

TEST RESULT CERTIFICATION

Applicant : Sinco Intelligent Technology Co., Ltd.
Address : Workshop D-2, Assembly Workshop, North Airport Road, Hongqi
Town, Jinwan District, Zhuhai, China
Manufacturer : Sinco Intelligent Technology Co., Ltd.
Address : Workshop D-2, Assembly Workshop, North Airport Road, Hongqi
Town, Jinwan District, Zhuhai, China

Product description

Product : Wireless System
Trade Name : M-VAVE
Model Name : WP-10, WP-1, WP-2, WP-3, WP-4, WP-5, WP-6, WP-7, WP-8,
WP-9, WP-11, WP-12, GWM-11, LEM-01, WAVE AIR 2
GWM-12, SWS1, SWS2, SWS3, SWS4, SWS5, SWS6, SWS7,
SWS8, SWS9, SWS10, SWS11, SWS12
Test Methods : FCC Rules and Regulations Part 15 Subpart C Section 15.249,
ANSI C63.10: 2013

This device described above has been tested by Shenzhen United Testing Technology Co., Ltd., and the test results show that the equipment under test (EUT) is in compliance with the FCC requirements. And it is applicable only to the tested sample identified in the report.

This report shall not be reproduced except in full, without the written approval of UNI, this document may be altered or revised by Shenzhen United Testing Technology Co., Ltd., personnel only, and shall be noted in the revision of the document.

Date of Test :
Date (s) of performance of tests : Jun. 17, 2022 ~ Jun. 24, 2022
Date of Issue : Jun. 30, 2022
Test Result : Pass

Prepared by:

kahn.yang

Kahn yang/Supervisor

Reviewer:

Kelly Cheng/Supervisor

Approved & Authorized Signer:

Liuze/Manager

Table of Contents	Page
1 TEST SUMMARY	4
2 GENERAL INFORMATION	6
2.1 GENERAL DESCRIPTION OF EUT	6
2.2 CARRIER FREQUENCY OF CHANNELS	7
2.3 TEST MODE	7
2.4 TEST SETUP	7
2.5 DESCRIPTION TEST PERIPHERAL AND EUT PERIPHERAL	8
2.6 MEASUREMENT INSTRUMENTS LIST	9
3 CONDUCTED EMISSION	10
3.1 TEST LIMIT	10
3.2 TEST SETUP	10
3.3 TEST PROCEDURE	11
3.4 TEST RESULT	11
4 RADIATED EMISSION	14
4.1 TEST LIMIT	14
4.2 TEST SETUP	15
4.3 TEST PROCEDURE	16
4.4 TEST RESULT	16
5 BAND EDGE	23
5.1 TEST LIMIT	23
5.2 TEST PROCEDURE	23
5.3 TEST RESULT	23
6 OCCUPIED BANDWIDTH	26
6.1 TEST SETUP	26
6.2 TEST PROCEDURE	26
6.4 TEST RESULT	26
7 ANTENNA REQUIREMENT	28
8 PHOTO OF TEST	29
8.1 RADIATED EMISSION	29
8.2 CONDUCTED EMISSION	30

1 TEST SUMMARY

1.1 TEST PROCEDURES AND RESULTS

ITEM	STANGARD	RESULT
CONDUCTED EMISSION	FCC Part 15.207	COMPLIANT
RADIATED EMISSION	FCC Part 15.209/15.249	COMPLIANT
BAND EDGE	FCC Part 15.249/15.205	COMPLIANT
OCCUPIED BANDWIDTH	FCC Part 15.215	COMPLIANT
ANTENNA REQUIREMENT	FCC Part 15.203	COMPLIANT

1.2 TEST FACILITY

Test Firm : Shenzhen United Testing Technology Co., Ltd.
Address : 2F, Annex Bldg, Jiahuangyuan Tech Park, #365 Baotian 1 Rd, Tiegang Community, Xixiang Str, Bao'an District, Shenzhen, China

The testing quality ability of our laboratory meet with "Quality Law of People's Republic of China" Clause 19. The testing quality system of our laboratory meets with ISO/IEC-17025 requirements. This approval result is accepted by MRA of APLAC.

Our test facility is recognized, certified, or accredited by the following organizations:

A2LA Certificate Number: 4747.01

The EMC Laboratory has been accredited by A2LA, and in compliance with ISO/IEC 17025:2017 General Requirements for testing Laboratories.

FCC Registration Number: 674885

The EMC Laboratory has been registered and fully described in a report filed with the (FCC) Federal Communications commission.

IC Registration Number: 21947

The EMC Laboratory has been registered and fully described in a report filed with the (IC) Industry Canada.

1.3 MEASUREMENT UNCERTAINTY

The reported uncertainty of measurement $y \pm U$, where expanded uncertainty U is based on a standard uncertainty multiplied by a coverage factor of $k=2$, providing a level of confidence of approximately 95 %.

A. Conducted Measurement:

Test Site	Method	Measurement Frequency Range	U, (dB)	NOTE
UNI	ANSI	9kHz ~ 150kHz	2.96	
		150kHz ~ 30MHz	2.44	

B. Radiated Measurement:

Test Site	Method	Measurement Frequency Range	U, (dB)	NOTE
UNI	ANSI	9kHz ~ 30MHz	2.50	
		30MHz ~ 1000MHz	4.80	
		Above 1000MHz	4.13	

2 GENERAL INFORMATION

2.1 GENERAL DESCRIPTION OF EUT

Product:	Wireless System
Trade Name:	M-VAVE
Main Model:	WP-10
Additional Model:	WP-1, WP-2, WP-3, WP-4, WP-5, WP-6, WP-7, WP-8, WP-9, WP-11, WP-12, GWM-11, LEM-01, WAVE AIR 2 GWM-12, SWS1, SWS2, SWS3, SWS4, SWS5, SWS6, SWS7, SWS8, SWS9, SWS10, SWS11, SWS12
Model Difference:	All model's the function, software and electric circuit are the same, only with a product color and model named different. Test sample model: WP-10.
FCC ID:	2ARCP-WP-10
Operation Frequency:	2403MHz~2478MHz
Number of Channels:	26CH
Modulation Type:	GFSK
Antenna Type:	PCB Antenna
Antenna Gain:	0dBi
Battery:	DC 3.7V, 780mAh
Adapter:	N/A
Power Source:	DC 3.7V from Li-battery or DC 5.0V from adapter with AC 120(240)V/60Hz

2.2 CARRIER FREQUENCY OF CHANNELS

Channel List							
Channel	Frequency (MHz)	Channel	Frequency (MHz)	Channel	Frequency (MHz)	Channel	Frequency (MHz)
01	2403	08	2424	15	2445	22	2466
02	2406	09	2427	16	2448	23	2469
03	2409	10	2430	17	2451	24	2472
04	2412	11	2433	18	2454	25	2475
05	2415	12	2436	19	2457	26	2478
06	2418	13	2439	20	2460		
07	2421	14	2442	21	2463		

2.3 TEST MODE

The EUT was programmed to be in continuously transmitting mode.

Channel List		
Test Channel	EUT Channel	Test Frequency (MHz)
Low	CH01	2403
Middle	CH13	2439
High	CH26	2478

2.4 TEST SETUP

Operation of EUT during Conducted and Below 1GHz Radiation testing:



Operation of EUT during Above 1GHz Radiation testing:



2.5 DESCRIPTION TEST PERIPHERAL AND EUT PERIPHERAL

The EUT has been tested as an independent unit together with other necessary accessories or support units. The following support units or accessories were used to form a representative test configuration during the tests.

Item	Equipment	Mfr/Brand	Model/Type No.	Note
E-1	Wireless System	M-VAVE	WP-10	EUT
E-2	Adapter	XIAOMI	MDY-08-EF	AE

Item	Shielded Type	Ferrite Core	Length	Note

Note:

1. The support equipment was authorized by Declaration of Confirmation.
2. For detachable type I/O cable should be specified the length in cm in 『Length』 column.
3. “YES” is means “shielded” “with core”; “NO” is means “unshielded” “without core”.

2.6 MEASUREMENT INSTRUMENTS LIST

Item	Equipment	Manufacturer	Model No.	Serial No.	Calibrated until
Conduction Emissions Measurement					
1	Conducted Emission Test Software	EZ-EMC	Ver.CCS-3A1-CE	N/A	N/A
2	AMN	Schwarzbeck	NNLK8121	8121370	2022.09.22
3	AAN	TESEQ	T8-Cat6	38888	2022.09.22
4	Pulse Limiter	CYBRTEK	EM5010	E115010056	2023.05.30
5	EMI Test Receiver	Rohde&Schwarz	ESCI	101210	2022.09.22
Radiated Emissions Measurement					
1	Radiated Emission Test Software	EZ-EMC	Ver.CCS-03A1	N/A	N/A
2	Horn Antenna	Sunol	DRH-118	A101415	2022.09.27
3	Broadband Hybrid Antenna	Sunol	JB1	A090215	2024.02.26
4	PREAMP	HP	8449B	3008A00160	2022.09.22
5	PREAMP	HP	8447D	2944A07999	2023.05.30
6	EMI TEST RECEIVER	Rohde&Schwarz	ESR3	101891	2022.09.22
7	VECTOR Signal Generator	Rohde&Schwarz	SMU200A	101521	2022.09.22
8	Signal Generator	Agilent	E4421B	MY4335105	2022.09.22
9	MXA Signal Analyzer	Agilent	N9020A	MY50510140	2022.09.22
10	MXA Signal Analyzer	Keysight	N9020A	MY51110104	2022.09.22
11	RF Power sensor	DARE	RPR3006W	15I00041SNO88	2023.05.30
12	RF Power sensor	DARE	RPR3006W	15I00041SNO89	2023.05.30
13	RF power divider	Anritsu	K241B	992289	2022.09.22
14	Wideband radio communication tester	Rohde&Schwarz	CMW500	154987	2022.09.22
15	Active Loop Antenna	Com-Power	AL-130R	10160009	2023.05.30
16	Broadband Hybrid Antennas	Schwarzbeck	VULB9163	VULB9163#958	2022.09.22
17	Horn Antenna	Schwarzbeck	BBHA9120D	9120D-1680	2023.05.30
18	Horn Antenna	A-INFOMW	LB-180400-KF	J211060660	2022.09.27
19	Microwave Broadband Preampfier	Schwarzbeck	BBV 9721	100472	2022.09.22
20	Signal Generator	Agilent	N5183A	MY47420153	2022.09.22
21	Spectrum Analyzer	Rohde&Schwarz	FSP 40	100501	2022.09.22
22	Power Meter	KEYSIGHT	N1911A	MY50520168	2022.09.22
23	Frequency Meter	VICTOR	VC2000	997406086	2022.09.22
24	DC Power Source	HYELEC	HY5020E	055161818	2022.09.22

3 CONDUCTED EMISSION

3.1 TEST LIMIT

For unintentional device, according to § 15.207(a) Line Conducted Emission Limits is as following

Frequency (MHz)	Maximum RF Line Voltage (dB μ V)			
	CLASS A		CLASS B	
	Q.P.	Ave.	Q.P.	Ave.
0.15~0.50	79	66	66~56*	56~46*
0.50~5.00	73	60	56	46
5.00~30.0	73	60	60	50

* Decreasing linearly with the logarithm of the frequency.

For intentional device, according to §15.207(a) Line Conducted Emission Limit is same as above table.

3.2 TEST SETUP

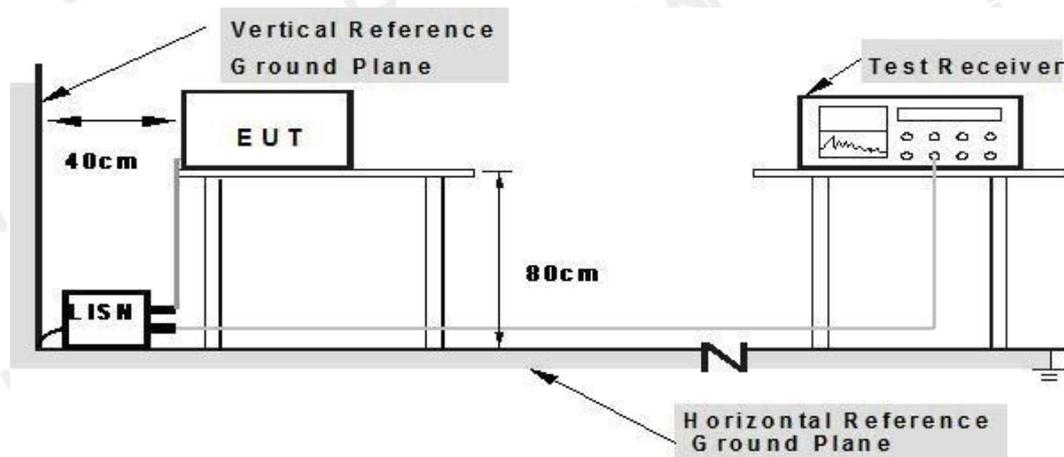

- Note: 1. Support units were connected to second LISN.**
2. Both of LISNs (AMN) are 80 cm from EUT and at least 80 cm from other units and other metal planes

3.3 TEST PROCEDURE

1. The equipment was set up as per the test configuration to simulate typical actual usage per the user's manual. The EUT is placed on a wooden table with a height of 0.8 meters is used and is placed on the ground plane as per ANSI C63.10.
2. Support equipment, if needed, was placed as per ANSI C63.10.
3. All I/O cables were positioned to simulate typical actual usage as per ANSI C63.10.
4. If a EUT received DC power from the USB Port of Notebook PC, the PC's adapter received AC120V/60Hz power through a Line Impedance Stabilization Network (LISN) which supplied power source and was grounded to the ground plane.
5. All support equipments received AC power from a second LISN, if any.
6. The EUT test program was started. Emissions were measured on each current carrying line of the EUT using a spectrum Analyzer / Receiver connected to the LISN powering the EUT. The LISN has two monitoring points: Line 1 (Hot Side) and Line 2 (Neutral Side). Two scans were taken: one with Line 1 connected to Analyzer / Receiver and Line 2 connected to a 50 ohm load; the second scan had Line 1 connected to a 50 ohm load and Line 2 connected to the Analyzer / Receiver.
7. Analyzer / Receiver scanned from 150 kHz to 30MHz for emissions in each of the test modes.

3.4 TEST RESULT

PASS

Remark:

1. All modes were tested at AC 120V and 240V, only the worst result of AC 120V was reported.
2. All modes were test at Low, Middle, and High channel, only the worst result of GFSK Low Channel was reported.

Temperature:	24°C	Relative Humidity:	48%
Test Date:	Jun. 21, 2022	Pressure:	1010hPa
Test Voltage:	AC 120V, 60Hz	Phase:	Line
Test Mode:	Transmitting mode of GFSK 2403MHz		

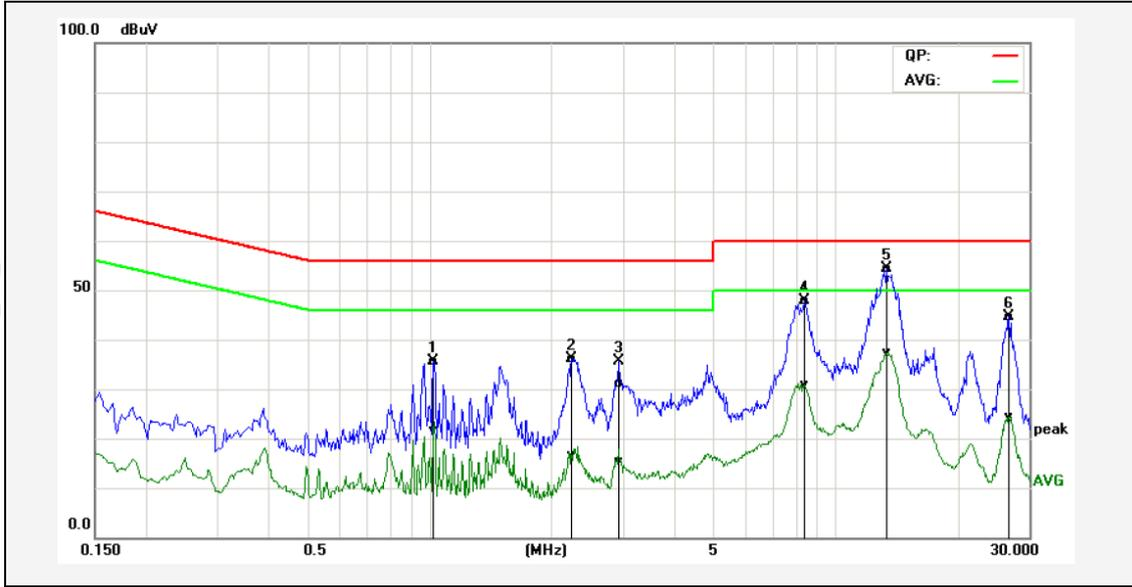

No.	Frequency (MHz)	QuasiPeak reading (dBuV)	Average reading (dBuV)	Correction factor (dB)	QuasiPeak result (dBuV)	Average result (dBuV)	QuasiPeak limit (dBuV)	Average limit (dBuV)	QuasiPeak margin (dB)	Average margin (dB)	Remark
1P	1.0260	25.50	11.43	10.12	35.62	21.55	56.00	46.00	-20.38	-24.45	Pass
2P	2.2380	26.07	6.61	10.13	36.20	16.74	56.00	46.00	-19.80	-29.26	Pass
3P	2.8900	20.95	5.23	10.17	31.12	15.40	56.00	46.00	-24.88	-30.60	Pass
4P	8.3979	37.63	20.62	10.18	47.81	30.80	60.00	50.00	-12.19	-19.20	Pass
5*	13.3580	44.05	27.20	10.21	54.26	37.41	60.00	50.00	-5.74	-12.59	Pass
6P	26.7500	34.02	13.77	10.71	44.73	24.48	60.00	50.00	-15.27	-25.52	Pass

Remark: Factor = Insertion Loss + Cable Loss, Result = Reading + Factor, Margin = Result – Limit.

Temperature:	24°C	Relative Humidity:	48%
Test Date:	Jun. 21, 2022	Pressure:	1010hPa
Test Voltage:	AC 120V, 60Hz	Phase:	Neutral
Test Mode:	Transmitting mode of GFSK 2403MHz		

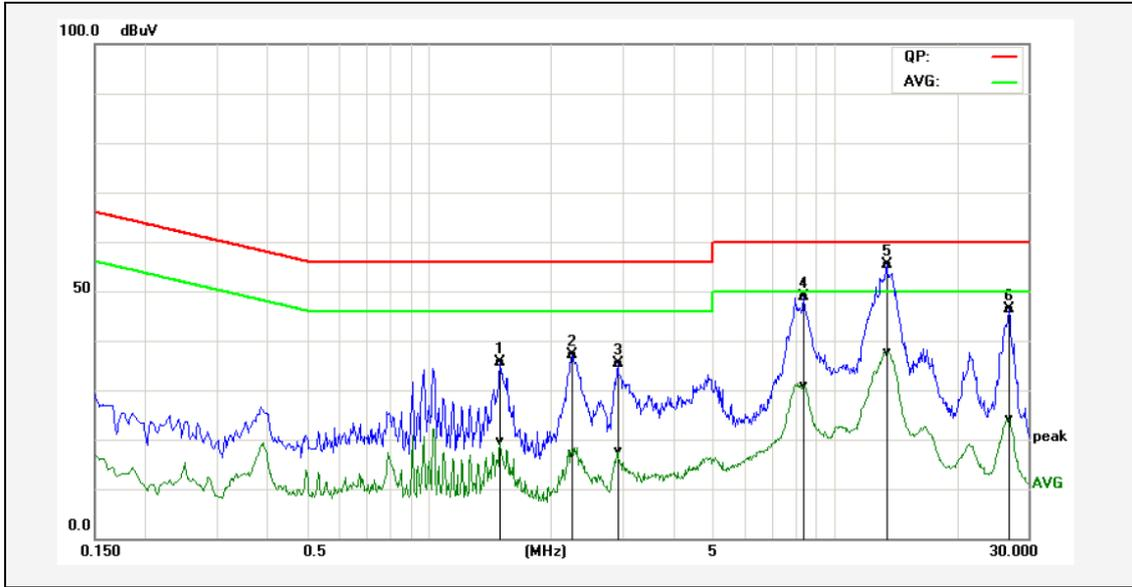

No.	Frequency (MHz)	QuasiPeak reading (dBuV)	Average reading (dBuV)	Correction factor (dB)	QuasiPeak result (dBuV)	Average result (dBuV)	QuasiPeak limit (dBuV)	Average limit (dBuV)	QuasiPeak margin (dB)	Average margin (dB)	Remark
1P	1.4980	25.60	9.54	10.10	35.70	19.64	56.00	46.00	-20.30	-26.36	Pass
2P	2.2580	26.95	7.07	10.13	37.08	17.20	56.00	46.00	-18.92	-28.80	Pass
3P	2.9180	25.16	7.38	10.17	35.33	17.55	56.00	46.00	-20.67	-28.45	Pass
4P	8.3820	38.62	20.81	10.18	48.80	30.99	60.00	50.00	-11.20	-19.01	Pass
5*	13.4740	45.28	27.44	10.21	55.49	37.65	60.00	50.00	-4.51	-12.35	Pass
6P	26.9100	35.42	13.36	10.85	46.27	24.21	60.00	50.00	-13.73	-25.79	Pass

Remark: Factor = Insertion Loss + Cable Loss, Result = Reading + Factor, Margin = Result – Limit.

4 RADIATED EMISSION

4.1 TEST LIMIT

For unintentional device, according to § 15.209(a), except for Class B digital devices, the field strength of radiated emissions from unintentional radiators at a distance of 3 meters shall not exceed the following values:

Frequency	Field strength (microvolt/meter)	Limit (dBuV/m)	Remark	Measurement distance (m)
0.009MHz-0.490MHz	2400/F (kHz)	-	Quasi-peak	300
0.490MHz-1.705MHz	24000/F (kHz)	-	Quasi-peak	30
1.705MHz-30MHz	30	-	Quasi-peak	30
30MHz-88MHz	100	40.0	Quasi-peak	3
88MHz-216MHz	150	43.5	Quasi-peak	3
216MHz-960MHz	200	46.0	Quasi-peak	3
960MHz-1GHz	500	54.0	Quasi-peak	3
Above 1GHz	500	54.0	Average	3
		74.0	Peak	3

For intentional device, according to § 15.209(a), the general requirement of field strength of radiated emissions from intentional radiators at a distance of 3 meters shall not exceed the above table.

Limit: (Field strength of the fundamental signal)

Frequency	Limit (dBuV/m @3m)	Remark
2400MHz-2483.5MHz	94.0	Average Value
	114.0	Peak Value

4.2 TEST SETUP

1. Radiated Emission Test-Up Frequency Below 30MHz

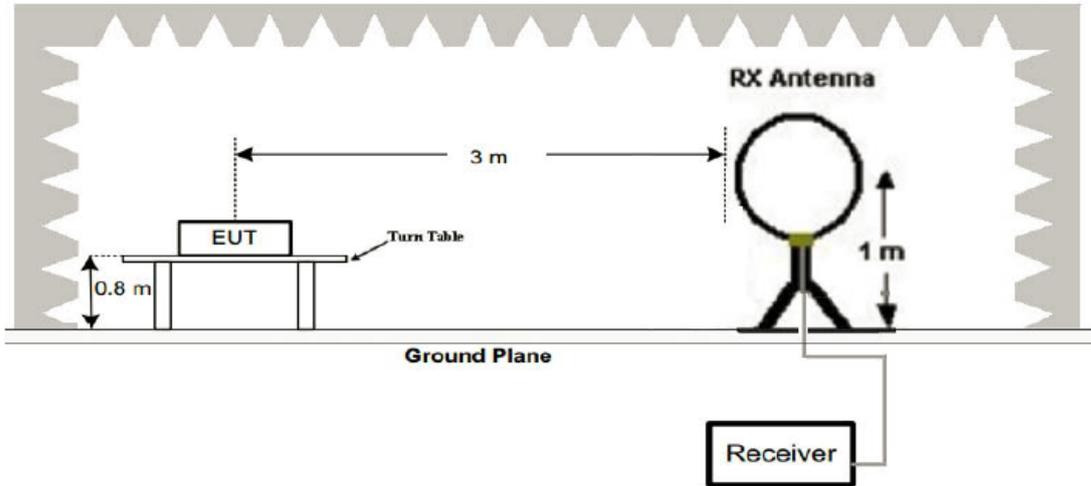

2. Radiated Emission Test-Up Frequency 30MHz~1GHz

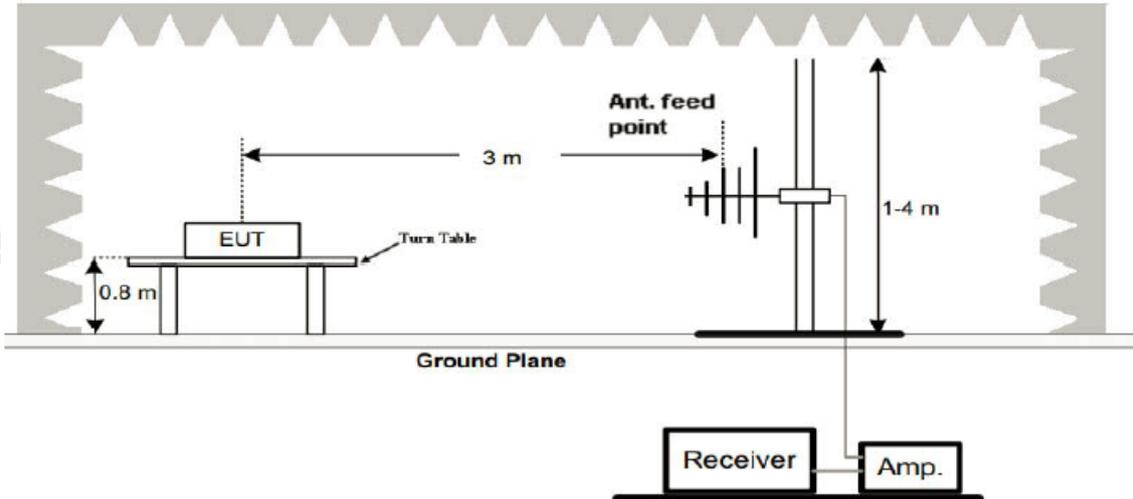

3. Radiated Emission Test-Up Frequency Above 1GHz

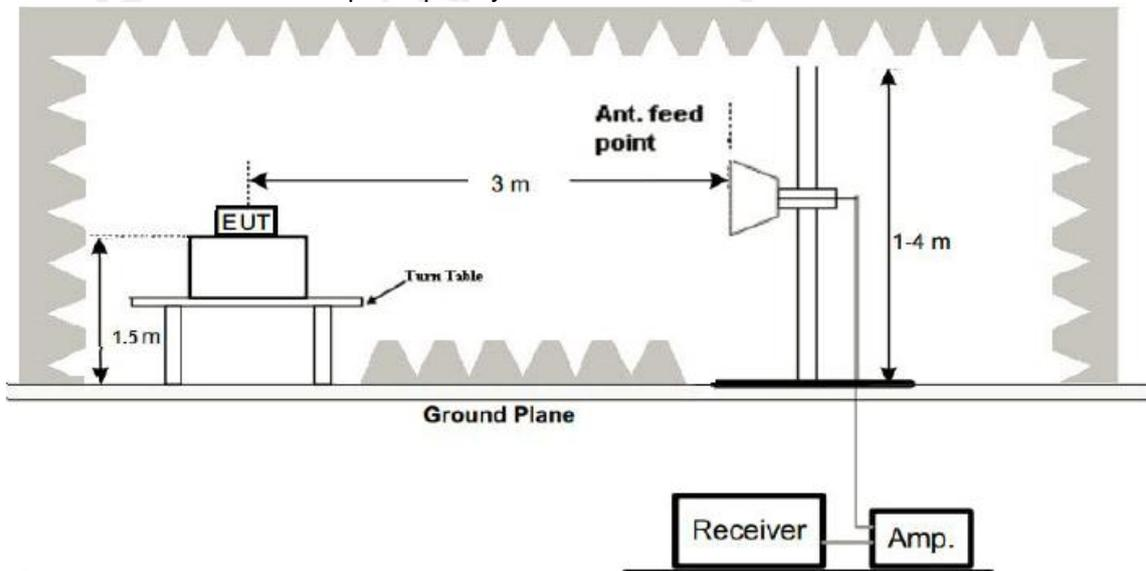

4.3 TEST PROCEDURE

1. Below 1GHz measurement the EUT is placed on turntable which is 0.8m above ground plane.
And above 1GHz measurement EUT was placed on low permittivity and low tangent turn table which is 1.5m above ground plane.
2. The turntable shall be rotated for 360 degrees to determine the position of maximum emission level.
3. EUT is set 3m away from the receiving antenna, which is varied from 1m to 4m to find out the highest emissions.
4. Maximum procedure was performed on the six highest emissions to ensure EUT compliance.
5. And also, each emission was to be maximized by changing the polarization of receiving antenna both horizontal and vertical.
6. Repeat above procedures until the measurements for all frequencies are complete.
7. The test frequency range from 9kHz to 25GHz per FCC PART 15.33(a).

Note:

For battery operated equipment, the equipment tests shall be performed using a new battery.

4.4 TEST RESULT

PASS

Remark:

1. All modes were test at Low, Middle, and High channel, only the worst result of GFSK Low Channel was reported for below 1GHz test.
2. By preliminary testing and verifying three axis (X, Y and Z) position of EUT transmitted status, it was found that "X axis" position was the worst, and test data recorded in this report.
3. Radiated emission test from 9kHz to 10th harmonic of fundamental was verified, and no emission found except system noise floor in 9kHz to 30MHz and not recorded in this report.

Below 1GHz Test Results:

Temperature:	24°C	Relative Humidity:	48%
Test Date:	Jun. 21, 2022	Pressure:	1010hPa
Test Voltage:	AC 120V, 60Hz	Phase:	Horizontal
Test Mode:	Transmitting mode of GFSK 2403MHz		

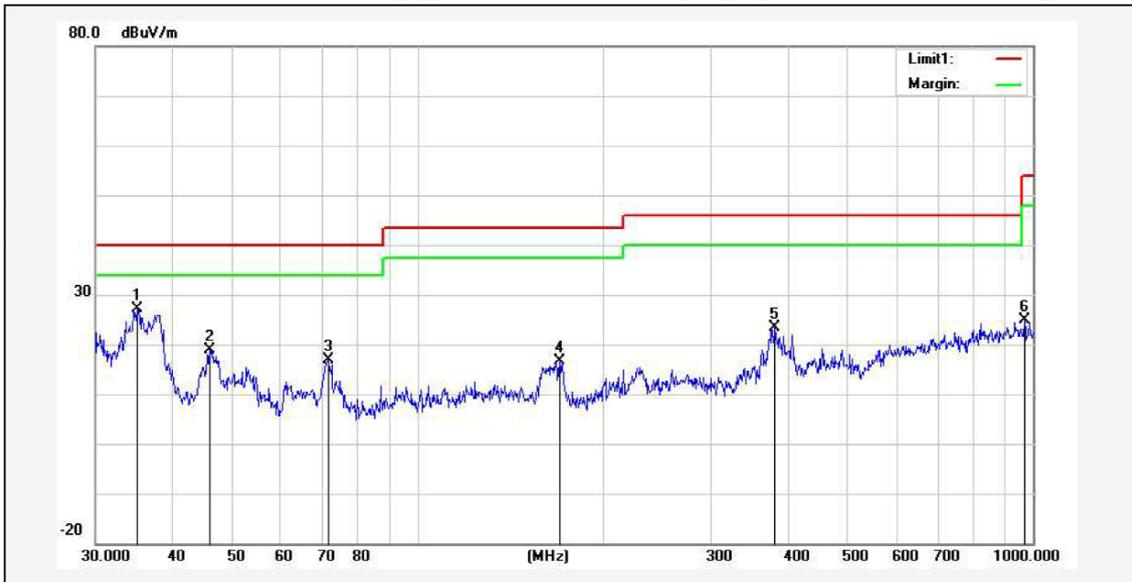

No.	Frequency (MHz)	Reading (dBuV)	Correction factor(dB/m)	Result (dBuV/m)	Limit (dBuV/m)	Margin (dB)	Degree (deg.)	Height (cm)	Remark
1*	35.0048	38.09	-10.87	27.22	40.00	-12.78	70	100	peak
2	46.0164	37.48	-18.55	18.93	40.00	-21.07	100	100	peak
3	71.8320	37.47	-20.69	16.78	40.00	-23.22	110	100	peak
4	170.1948	33.56	-16.90	16.66	43.50	-26.84	120	100	peak
5	381.2487	37.12	-13.63	23.49	46.00	-22.51	160	100	peak
6	968.9338	30.12	-5.24	24.88	54.00	-29.12	180	100	peak

Remark: Absolute Level = Reading Level + Factor, Margin = Absolute Level – Limit
 Factor = Ant. Factor + Cable Loss – Pre-amplifier

Temperature:	24°C	Relative Humidity:	48%
Test Date:	Jun. 21, 2022	Pressure:	1010hPa
Test Voltage:	AC 120V, 60Hz	Phase:	Vertical
Test Mode:	Transmitting mode of GFSK 2403MHz		

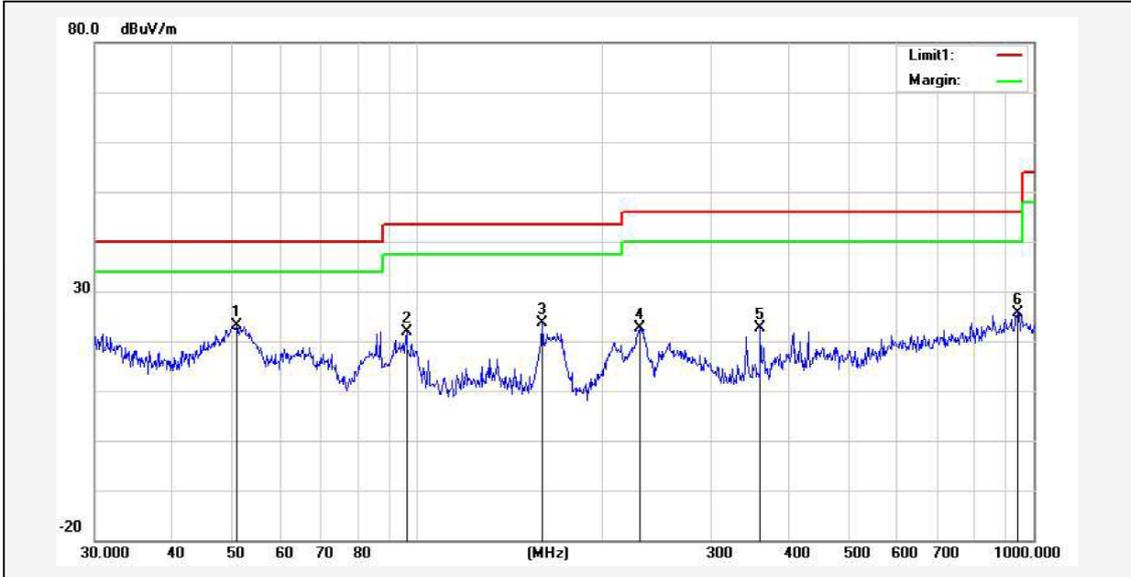

No.	Frequency (MHz)	Reading (dBuV)	Correction factor(dB/m)	Result (dBuV/m)	Limit (dBuV/m)	Margin (dB)	Degree (deg.)	Height (cm)	Remark
1*	50.9420	43.46	-20.43	23.03	40.00	-16.97	80	100	peak
2	96.0986	41.57	-19.74	21.83	43.50	-21.67	110	100	peak
3	159.7844	40.17	-16.64	23.53	43.50	-19.97	150	100	peak
4	229.2931	40.26	-17.56	22.70	46.00	-23.30	160	100	peak
5	360.4476	36.65	-13.92	22.73	46.00	-23.27	180	100	peak
6	942.1305	30.86	-5.15	25.71	46.00	-20.29	200	100	peak

Remark: Absolute Level = Reading Level + Factor, Margin = Absolute Level – Limit
 Factor = Ant. Factor + Cable Loss – Pre-amplifier

Remark:

1. Measuring frequencies from 9 kHz to the 1 GHz, Radiated emission test from 9kHz to 30MHz was verified, and no any emission was found except system noise floor.
2. * denotes emission frequency which appearing within the Restricted Bands specified in provision of 15.205, then the general radiated emission limits in 15.209 apply.
3. The IF bandwidth of EMI Test Receiver between 30MHz to 1GHz was 120kHz, 1 MHz for measuring above 1 GHz, below 30MHz was 10kHz.

Above 1 GHz Test Results:
CH01 (2403MHz)

Horizontal:

Frequency (MHz)	Reading Result (dBμV)	Factor (dB)	Emission Level (dBμV/m)	Limits (dBμV/m)	Margin (dB)	Detector Type
2403	112.51	-5.84	106.67	114	-7.33	PK
2403	82.54	-5.84	76.70	94	-17.30	AV
4806	60.20	-3.64	56.56	74	-17.44	PK
4806	50.24	-3.64	46.60	54	-7.40	AV
7209	57.05	-0.95	56.10	74	-17.90	PK
7209	47.26	-0.95	46.31	54	-7.69	AV

Remark: Factor = Antenna Factor + Cable Loss – Pre-amplifier. Margin = Absolute Level – Limit

Vertical:

Frequency (MHz)	Reading Result (dBμV)	Factor (dB)	Emission Level (dBμV/m)	Limits (dBμV/m)	Margin (dB)	Detector Type
2403	112.49	-5.84	106.65	114	-7.35	PK
2403	82.52	-5.84	76.68	94	-17.32	AV
4806	60.27	-3.64	56.63	74	-17.37	PK
4806	50.16	-3.64	46.52	54	-7.48	AV
7209	57.08	-0.95	56.13	74	-17.87	PK
7209	47.24	-0.95	46.29	54	-7.71	AV

Remark: Factor = Antenna Factor + Cable Loss – Pre-amplifier. Margin = Absolute Level – Limit

CH13 (2439MHz)

Horizontal:

Frequency (MHz)	Reading Result (dBμV)	Factor (dB)	Emission Level (dBμV/m)	Limits (dBμV/m)	Margin (dB)	Detector Type
2439	112.30	-5.71	106.59	114	-7.41	PK
2439	82.25	-5.71	76.54	94	-17.46	AV
4878	59.83	-3.51	56.32	74	-17.68	PK
4878	50.00	-3.51	46.49	54	-7.51	AV
7317	56.66	-0.82	55.84	74	-18.16	PK
7317	46.92	-0.82	46.10	54	-7.90	AV

Remark: Factor = Antenna Factor + Cable Loss – Pre-amplifier. Margin = Absolute Level – Limit

Vertical:

Frequency (MHz)	Reading Result (dBμV)	Factor (dB)	Emission Level (dBμV/m)	Limits (dBμV/m)	Margin (dB)	Detector Type
2439	112.31	-5.71	106.60	114	-7.40	PK
2439	82.21	-5.71	76.50	94	-17.50	AV
4878	59.76	-3.51	56.25	74	-17.75	PK
4878	50.03	-3.51	46.52	54	-7.48	AV
7317	56.72	-0.82	55.90	74	-18.10	PK
7317	46.90	-0.82	46.08	54	-7.92	AV

Remark: Factor = Antenna Factor + Cable Loss – Pre-amplifier. Margin = Absolute Level – Limit

CH26 (2478MHz)

Horizontal:

Frequency (MHz)	Reading Result (dBμV)	Factor (dB)	Emission Level (dBμV/m)	Limits (dBμV/m)	Margin (dB)	Detector Type
2478	111.98	-5.65	106.33	114	-7.67	PK
2478	82.03	-5.65	76.38	94	-17.62	AV
4956	59.35	-3.43	55.92	74	-18.08	PK
4956	49.73	-3.43	46.30	54	-7.70	AV
7434	56.61	-0.75	55.86	74	-18.14	PK
7434	46.55	-0.75	45.80	54	-8.20	AV

Remark: Factor = Antenna Factor + Cable Loss – Pre-amplifier. Margin = Absolute Level – Limit

Vertical:

Frequency (MHz)	Reading Result (dBμV)	Factor (dB)	Emission Level (dBμV/m)	Limits (dBμV/m)	Margin (dB)	Detector Type
2478	112.00	-5.65	106.35	114	-7.65	PK
2478	81.99	-5.65	76.34	94	-17.66	AV
4956	59.41	-3.43	55.98	74	-18.02	PK
4956	49.77	-3.43	46.34	54	-7.66	AV
7434	56.50	-0.75	55.75	74	-18.25	PK
7434	46.49	-0.75	45.74	54	-8.26	AV

Remark: Factor = Antenna Factor + Cable Loss – Pre-amplifier. Margin = Absolute Level – Limit

Remark:

1. Measuring frequencies from 1 GHz to the 25 GHz.
2. "F" denotes fundamental frequency; "H" denotes spurious frequency. "E" denotes band edge frequency.
3. * denotes emission frequency which appearing within the Restricted Bands specified in provision of 15.205, then the general radiated emission limits in 15.209 apply.
4. Data of measurement within this frequency range shown "---" in the table above means the reading of emissions are attenuated more than 20dB below the permissible limits or the field strength is too small to be measured.
5. The IF bandwidth of EMI Test Receiver between 30MHz to 1GHz was 120kHz, 1 MHz for measuring above 1 GHz, below 30MHz was 10kHz. The resolution bandwidth of test receiver/spectrum analyzer is 1MHz and video bandwidth is 3MHz for peak measurement with peak detector at frequency above 1GHz. The resolution bandwidth of test receiver/spectrum analyzer is 1MHz and video bandwidth is 10Hz for Average measurement with peak detection at frequency above 1GHz.
6. When the test results of Peak Detected below the limits of Average Detected, the Average Detected is not need completed. For example: Top Channel at Fundamental 73.16dBuV/m(PK Value) <93.98(AV Limit), at harmonic 53.20 dBuV/m(PK Value) <54 dBuV/m(AV Limit), the Average Detected not need to completed.
7. All modes of operation were investigated and the worst-case emissions of $\pi/4$ DQPSK are reported.
8. For fundamental frequency, $RBW > 20dB$ BW, $VBW \geq 3XRBW$, PK detector for PK value, AV detector for AV value.

5 BAND EDGE

5.1 TEST LIMIT

FCC PART 15.249(d) Emissions radiated outside of the specified frequency bands, except for harmonics, shall be attenuated by at least 50 dB below the level of the fundamental or to the general radiated emission limits in §15.209, whichever is the lesser attenuation.

5.2 TEST PROCEDURE

The band edge compliance of RF radiated emission should be measured by following the guidance in ANSI C63.10 with respect to maximizing the emission by rotating the EUT, measuring the emission while the EUT is situated in three orthogonal planes (if appropriate), adjusting the measurement antenna height and polarization etc. Set RBW to 1MHz and VBM to 3MHz to measure the peak field strength and set RBW to 1MHz and VBW to 10Hz to measure the average radiated field strength. Peak detector is for both.

5.3 TEST RESULT

PASS

Operation Mode: TX CH01 (2403MHz)

Horizontal:

Frequency (MHz)	Reading Result (dBμV)	Factor (dB)	Emission Level (dBμV/m)	Limits (dBμV/m)	Margin (dB)	Detector Type
2310	57.24	-5.81	51.43	74	-22.57	PK
2310	/	-5.81	/	54	/	AV
2390	57.36	-5.84	51.52	74	-22.48	PK
2390	/	-5.84	/	54	/	AV
2400	57.44	-5.84	51.60	74	-22.40	PK
2400	/	-5.84	/	54	/	AV

Remark: Factor = Antenna Factor + Cable Loss – Pre-amplifier.

Vertical:

Frequency (MHz)	Reading Result (dBμV)	Factor (dB)	Emission Level (dBμV/m)	Limits (dBμV/m)	Margin (dB)	Detector Type
2310	57.52	-5.81	51.71	74	-22.29	PK
2310	/	-5.81	/	54	/	AV
2390	57.40	-5.84	51.56	74	-22.44	PK
2390	/	-5.84	/	54	/	AV
2400	57.28	-5.84	51.44	74	-22.56	PK
2400	/	-5.84	/	54	/	AV

Remark: Factor = Antenna Factor + Cable Loss – Pre-amplifier.

Operation Mode: TX CH26 (2478MHz)

Horizontal:

Frequency (MHz)	Reading Result (dB μ V)	Factor (dB)	Emission Level (dB μ V/m)	Limits (dB μ V/m)	Margin (dB)	Detector Type
2483.5	57.10	-5.65	51.45	74	-22.55	PK
2483.5	/	-5.65	/	54	/	AV
2500	57.30	-5.72	51.58	74	-22.42	PK
2500	/	-5.72	/	54	/	AV

Remark: Factor = Antenna Factor + Cable Loss – Pre-amplifier.

Vertical:

Frequency (MHz)	Reading Result (dB μ V)	Factor (dB)	Emission Level (dB μ V/m)	Limits (dB μ V/m)	Margin (dB)	Detector Type
2483.5	57.15	-5.65	51.50	74	-22.50	PK
2483.5	/	-5.65	/	54	/	AV
2500	57.14	-5.72	51.42	74	-22.58	PK
2500	/	-5.72	/	54	/	AV

Remark: Factor = Antenna Factor + Cable Loss – Pre-amplifier.

6 OCCUPIED BANDWIDTH

6.1 TEST SETUP

Same as Radiated Emission Measurement.

6.2 TEST PROCEDURE

1. The EUT was placed on a turn table which is 0.8m above ground plane.
2. Set EUT as normal operation.
3. Based on ANSI C63.10 section 6.9.2: RBW=30kHz, VBW=100kHz, Span=3MHz.
4. The useful radiated emission from the EUT was detected by the spectrum analyzer with peak detector.

6.4 TEST RESULT

PASS

GFSK Modulation:

Channel	Frequency (MHz)	20dB Bandwidth (MHz)	Result
CH01	2403	3.078	PASS
CH13	2439	3.076	PASS
CH26	2478	3.080	PASS

CH01: 2403MHz



CH13: 2439MHz



CH26: 2478MHz

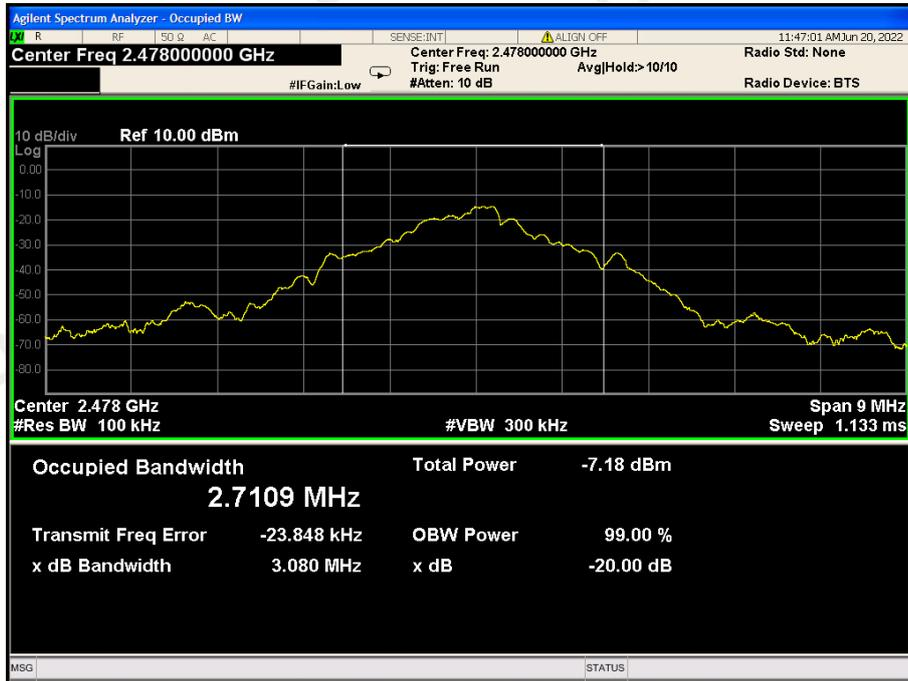

7 ANTENNA REQUIREMENT

Standard Applicable:

For intentional device, according to FCC 47 CFR Section 15.203, an intentional radiator shall be designed to ensure that no antenna other than that furnished by the responsible party shall be used with the device.

Antenna Connected Construction

The antenna used in this product is a PCB Antenna, The directional gains of antenna used for transmitting is 0dBi.

ANTENNA:

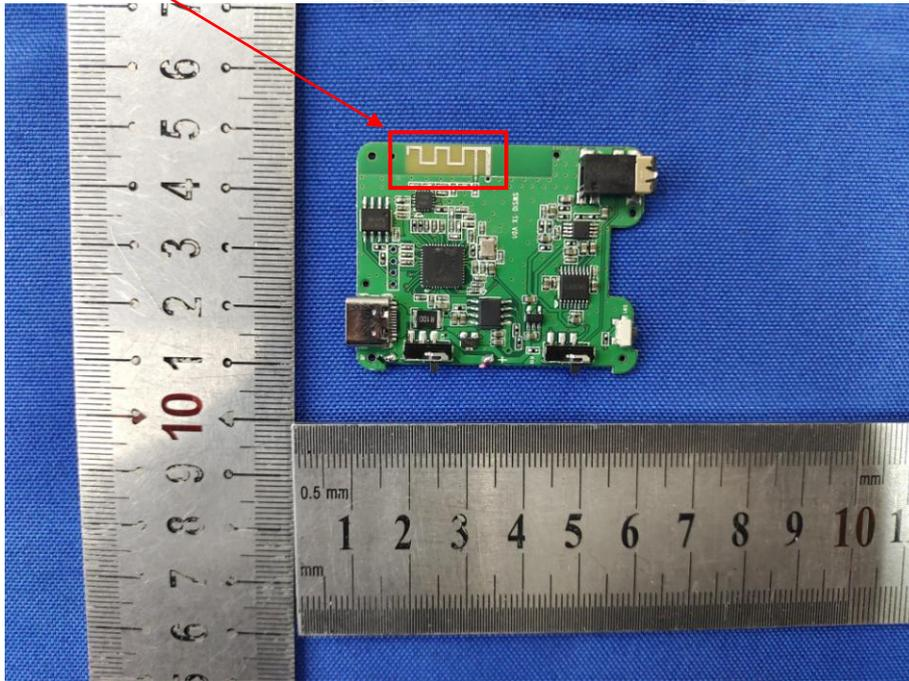

8 PHOTO OF TEST

8.1 RADIATED EMISSION



8.2 CONDUCTED EMISSION



End of Report