

FCC RADIO TEST REPORT

FCC ID: 2ARCP-CUBETURNER

Sample : Wireless page turner pedal

Trade Name : M-VAVE, Lekato, Asmuse, Playwell

Main Model : CUBE TURNER PRO

Additional Model : CUBE TURNER PLUS, SK-001,
TURNER II, VAVE368

Report No. : UNIA23103115ER-61

Prepared for

Sinco Intelligent Technology Co., Ltd.

Workshop D-2, Assembly Workshop, North Airport Road, Hongqi Town,
Jinwan District, Zhuhai China

Prepared by

Shenzhen United Testing Technology Co., Ltd.

D101&D401, No. 107, Kaicheng High-Tech Park, Taoyuan Community,
Dalang Sub-District, Longhua District, Shenzhen, Guangdong, China

TEST RESULT CERTIFICATION

Applicant : Sinco Intelligent Technology Co., Ltd.
Address : Workshop D-2,Assembly Workshop,North Airport Road,
 Hongqi Town,Jinwan District,Zhuhai China

Manufacturer : Sinco Intelligent Technology Co., Ltd.
Address : Workshop D-2,Assembly Workshop,North Airport Road,
 Hongqi Town,Jinwan District,Zhuhai China

Product description

Product : Wireless page turner pedal
Trade Mark : M-VAVE, Lekato, Asmuse, Playwell
Model Name : CUBE TURNER PRO, CUBE TURNER PLUS, SK-001,
 TURNER II, VAVE368

Test Methods : FCC Rules and Regulations Part 15 Subpart C Section 15.249,
 ANSI C63.10: 2013

This device described above has been tested by Shenzhen United Testing Technology Co., Ltd., and the test results show that the equipment under test (EUT) is in compliance with the FCC requirements. And it is applicable only to the tested sample identified in the report. This report shall not be reproduced except in full, without the written approval, this document may be altered or revised by Shenzhen United Testing Technology Co., Ltd., personnel only, and shall be noted in the revision of the document.

Date of Test

Date (s) of performance of tests : Oct. 31, 2023 ~ Nov. 16, 2023
Date of Issue : Nov. 20, 2023
Test Result : Pass

Prepared by:



Jason Ye/Editor

Reviewer:



Kelly Cheng/Supervisor

Approved & Authorized Signer:

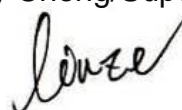

Liuze/Manager

Table of Contents	Pages
1 TEST SUMMARY	4
1.1 TEST PROCEDURES AND RESULTS	4
1.2 TEST FACILITY	5
1.3 MEASUREMENT UNCERTAINTY	6
1.4 ENVIRONMENTAL CONDITIONS	6
2 GENERAL INFORMATION	7
2.1 GENERAL DESCRIPTION OF EUT	7
2.2 CARRIER FREQUENCY OF CHANNELS	8
2.3 DESCRIPTION OF TEST MODES	8
2.4 TEST SETUP	9
2.5 EQUIPMENT USED IN TESTED SYSTEM	9
2.6 MEASUREMENT INSTRUMENTS LIST	10
3 CONDUCTED EMISSION	11
3.1 TEST LIMIT	11
3.2 TEST SETUP	11
3.3 TEST PROCEDURE	12
3.4 TEST RESULT	12
4 RADIATED EMISSION	15
4.1 TEST LIMIT	15
4.2 TEST SETUP	16
4.3 TEST PROCEDURE	17
4.4 TEST RESULT	17
5 BAND EDGE	23
5.1 TEST LIMIT	23
5.2 TEST SETUP	23
5.3 MEASUREMENT EQUIPMENT USED	23
5.4 TEST PROCEDURE	23
5.5 TEST RESULT	23
6 20dB Bandwidth	26
6.1 TEST SETUP (BLOCK DIAGRAM OF CONFIGURATION)	26
6.2 MEASUREMENT EQUIPMENT USED	26
6.3 TEST PROCEDURE	26
6.4 TEST RESULT	26
7 ANTENNA REQUIREMENT	29
8 PHOTO OF TEST	30

1 TEST SUMMARY

1.1 TEST PROCEDURES AND RESULTS

Item	FCC Rules	Description Of Test	Result
1	FCC Part 15.207	Conducted Emission	Pass
2	FCC Part 15.209/15.249	Radiated Emission	Pass
3	FCC Part 15.249/15.205	Band Edge	Pass
4	FCC Part 15.215	20dB Bandwidth	Pass
5	FCC Part 15.203	Antenna Requirement	Pass

Note:

“N/A” denotes test is not applicable in this Test Report.

1.2 TEST FACILITY

Test Firm : Shenzhen United Testing Technology Co., Ltd.
Address : D101&D401, No. 107, Kaicheng High-Tech Park, Taoyuan Community,
Dalang Sub-District, Longhua District, Shenzhen, Guangdong, China

The testing quality ability of our laboratory meet with "Quality Law of People's Republic of China" Clause 19. The testing quality system of our laboratory meets with ISO/IEC-17025 requirements. This approval result is accepted by MRA of APLAC.

Our test facility is recognized, certified, or accredited by the following organizations:

A2LA Certificate Number: 4747.01

The EMC Laboratory has been accredited by A2LA, and in compliance with ISO/IEC 17025:2017 General Requirements for testing Laboratories.

FCC Registration Number: 674885

The EMC Laboratory has been registered and fully described in a report filed with the (FCC) Federal Communications commission.

IC Registration Number: 31584

The EMC Laboratory has been registered and fully described in a report filed with the (IC) Industry Canada.

1.3 MEASUREMENT UNCERTAINTY

The reported uncertainty of measurement $y \pm U$, where expanded uncertainty U is based on a standard uncertainty multiplied by a coverage factor of $k=2$, providing a level of confidence of approximately 95 %.

A. Conducted Measurement:

Test Site	Method	Measurement Frequency Range	U, (dB)	NOTE
UNI	ANSI	9kHz ~ 150kHz	2.96	
		150kHz ~ 30MHz	2.44	

B. Radiated Measurement:

Test Site	Method	Measurement Frequency Range	U, (dB)	NOTE
UNI	ANSI	9kHz ~ 30MHz	2.50	
		30MHz ~ 1000MHz	4.80	
		Above 1000MHz	4.13	

C. RF Conducted Method:

Item	Measurement Uncertainty
Uncertainty of total RF power, conducted	$U_c = \pm 0.8$ dB
Uncertainty of RF power density, conducted	$U_c = \pm 2.6$ dB
Uncertainty of spurious emissions, conducted	$U_c = \pm 2$ %
Uncertainty of Occupied Channel Bandwidth	$U_c = \pm 2$ %

1.4 ENVIRONMENTAL CONDITIONS

During the measurement the environmental conditions were within the listed ranges:

	NORMAL CONDITIONS	EXTREME CONDITIONS
Temperature range (°C)	15 - 35	-20 - 50
Relative humidity range	20 % - 75 %	20 % - 75 %
Pressure range (kPa)	86 - 106	86 - 106
Note: The Extreme Temperature and Extreme Voltages declared by the manufacturer.		

2 GENERAL INFORMATION

2.1 GENERAL DESCRIPTION OF EUT

Product:	Wireless page turner pedal
Trade Mark:	M-VAVE, Lekato, Asmuse, Playwell
Main Model:	CUBE TURNER PRO
Additional Model:	CUBE TURNER PLUS, SK-001, TURNER II, VAVE368
Model Difference:	All model's the function, software and electric circuit are the same, only with a product color and model named different. Test sample model: CUBE TURNER PRO.
FCC ID:	2ARCP-CUBETURNER
Operation Frequency:	2402MHz~2480MHz
Number of Channels:	40CH
Field Strength of Fundamental:	94.41dBuV/m(Peak)@3m
Modulation Type:	GFSK
Antenna Type:	PCB Antenna
Antenna Gain:	0dBi
Battery:	DC 3.7V, 300mAh
Adapter:	N/A
Power Source:	DC 5.0V from adapter or DC 3.7V from Li-battery

2.2 CARRIER FREQUENCY OF CHANNELS

Channel List							
Channel	Frequency (MHz)	Channel	Frequency (MHz)	Channel	Frequency (MHz)	Channel	Frequency (MHz)
00	2402	10	2422	20	2442	30	2462
01	2404	11	2424	21	2444	31	2464
02	2406	12	2426	22	2446	32	2466
03	2408	13	2428	23	2448	33	2468
04	2410	14	2430	24	2450	34	2470
05	2412	15	2432	25	2452	35	2472
06	2414	16	2434	26	2454	36	2474
07	2416	17	2436	27	2456	37	2476
08	2418	18	2438	28	2458	38	2478
09	2420	19	2440	29	2460	39	2480

2.3 DESCRIPTION OF TEST MODES

No.	Test Mode Description
1	Low channel TX
2	Middle channel TX
3	High channel TX
<p>Note: 1. For Radiated Emission, 3axis were chosen for testing for each applicable mode. 2.For Conducted Test method,at emporary antenna connector is provided by the manufacture.</p>	

2.4 TEST SETUP

Operation of EUT during Conducted and Radiation testing:

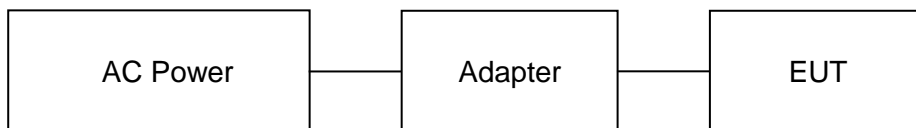

Operation of EUT during RF Conducted testing:

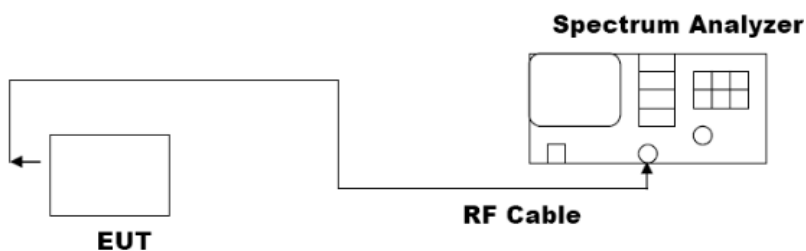

2.5 EQUIPMENT USED IN TESTED SYSTEM

Item	Equipment	Model/Type No.	Cable Length(m)	Note
1	Wireless page turner pedal	CUBE TURNER PRO	--	EUT
2	Adapter	MDY-11-EX	--	AE

Note:1. The support equipment was authorized by Declaration of Confirmation.

2. All the above equipment/cables were placed in worse case positions to maximize emission signals during emission test.

2.6 MEASUREMENT INSTRUMENTS LIST

Item	Equipment	Manufacturer	Model No.	Serial No.	Calibrated until
Conduction Emissions Measurement					
1	Conducted Emission Test Software	EZ-EMC	Ver.CCS-3A1-CE	N/A	N/A
2	AMN	Schwarzbeck	NNLK8121	8121370	2024.06.11
3	AAN	TESEQ	T8-Cat6	38888	2024.06.11
4	Pulse Limiter	CYBRTEK	EM5010	E115010056	2024.06.11
5	EMI Test Receiver	Rohde&Schwarz	ESCI	101210	2024.06.11
Radiated Emissions Measurement					
1	Radiated Emission Test Software	EZ-EMC	Ver.CCS-03A1	N/A	N/A
2	Horn Antenna	Sunol	DRH-118	A101415	2025.07.14
3	Broadband Hybrid Antenna	Sunol	JB1	A090215	2025.07.28
4	PREAMP	HP	8449B	3008A00160	2024.06.11
5	PREAMP	HP	8447D	2944A07999	2024.06.11
6	EMI TEST RECEIVER	Rohde&Schwarz	ESR3	101891	2024.06.11
7	VECTOR Signal Generator	Rohde&Schwarz	SMU200A	101521	2024.06.11
8	Signal Generator	Agilent	E4421B	MY4335105	2024.06.11
9	MXA Signal Analyzer	Agilent	N9020A	MY50510140	2024.06.11
10	MXA Signal Analyzer	Keysight	N9020A	MY51110104	2024.06.11
11	RF Power sensor	DARE	RPR3006W	15I00041SNO88	2024.06.11
12	RF Power sensor	DARE	RPR3006W	15I00041SNO89	2024.06.11
13	RF power divider	Anritsu	K241B	992289	2024.06.11
14	Wideband radio communication tester	Rohde&Schwarz	CMW500	154987	2024.06.11
15	Active Loop Antenna	Com-Power	AL-130R	10160009	2024.06.11
16	Broadband Hybrid Antennas	Schwarzbeck	VULB9163	VULB9163#958	2024.09.22
17	Horn Antenna	Schwarzbeck	BBHA9120D	9120D-1680	2025.07.14
18	Horn Antenna	A-INFOMW	LB-180400-KF	J211060660	2024.07.14
19	Microwave Broadband Preamplifier	Schwarzbeck	BBV 9721	100472	2024.09.22
20	Signal Generator	Agilent	N5183A	MY47420153	2024.09.22
21	Spectrum Analyzer	Rohde&Schwarz	FSP 40	100501	2024.09.22
22	Power Meter	KEYSIGHT	N1911A	MY50520168	2024.09.22
23	Frequency Meter	VICTOR	VC2000	997406086	2024.09.22
24	DC Power Source	HYELEC	HY5020E	055161818	2024.09.22

3 CONDUCTED EMISSION

3.1 TEST LIMIT

For unintentional device, according to § 15.207(a) Line Conducted Emission Limits is as following

Frequency (MHz)	Maximum RF Line Voltage (dB μ V)			
	CLASS A		CLASS B	
	Q.P.	Ave.	Q.P.	Ave.
0.15~0.50	79	66	66~56*	56~46*
0.50~5.00	73	60	56	46
5.00~30.0	73	60	60	50

* Decreasing linearly with the logarithm of the frequency.

For intentional device, according to §15.207(a) Line Conducted Emission Limit is same as above table.

3.2 TEST SETUP

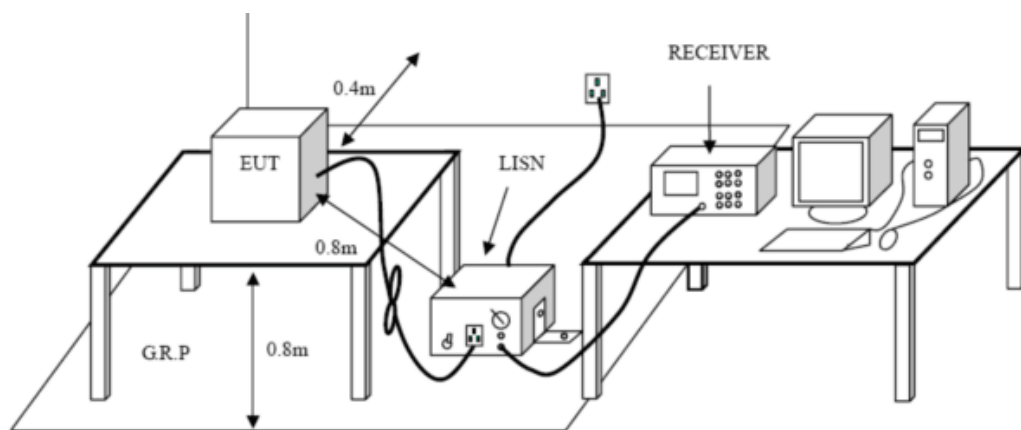

3.3 TEST PROCEDURE

1. The equipment was set up as per the test configuration to simulate typical actual usage per the user's manual. The EUT is placed on a wooden table with a height of 0.8 meters is used and is placed on the ground plane as per ANSI C63.10.
2. Support equipment, if needed, was placed as per ANSI C63.10.
3. All I/O cables were positioned to simulate typical actual usage as per ANSI C63.10.
4. If a EUT received DC power from the USB Port of adapter, the adapter received AC120V/60Hz power through a Line Impedance Stabilization Network (LISN) which supplied power source and was grounded to the ground plane.
5. All support equipments received AC power from a second LISN, if any.
6. The EUT test program was started. Emissions were measured on each current carrying line of the EUT using a spectrum Analyzer / Receiver connected to the LISN powering the EUT. The LISN has two monitoring points: Line 1 (Hot Side) and Line 2 (Neutral Side). Two scans were taken: one with Line 1 connected to Analyzer / Receiver and Line 2 connected to a 50 ohm load; the second scan had Line 1 connected to a 50 ohm load and Line 2 connected to the Analyzer / Receiver.
7. Analyzer / Receiver scanned from 150 kHz to 30MHz for emissions in each of the test modes.

3.4 TEST RESULT

PASS

Remark:

1. All modes were tested at AC 120V and 240V, only the worst result of AC 120V was reported.
2. All modes were test at Low, Middle, and High channel, only the worst result of GFSK Middle Channel was reported.

Temperature:	24°C	Relative Humidity:	48%
Test Date:	Nov. 01, 2023	Pressure:	1010hPa
Test Voltage:	AC 120V, 60Hz	Phase:	Line
Test Mode:	Transmitting mode of GFSK 2440MHz		

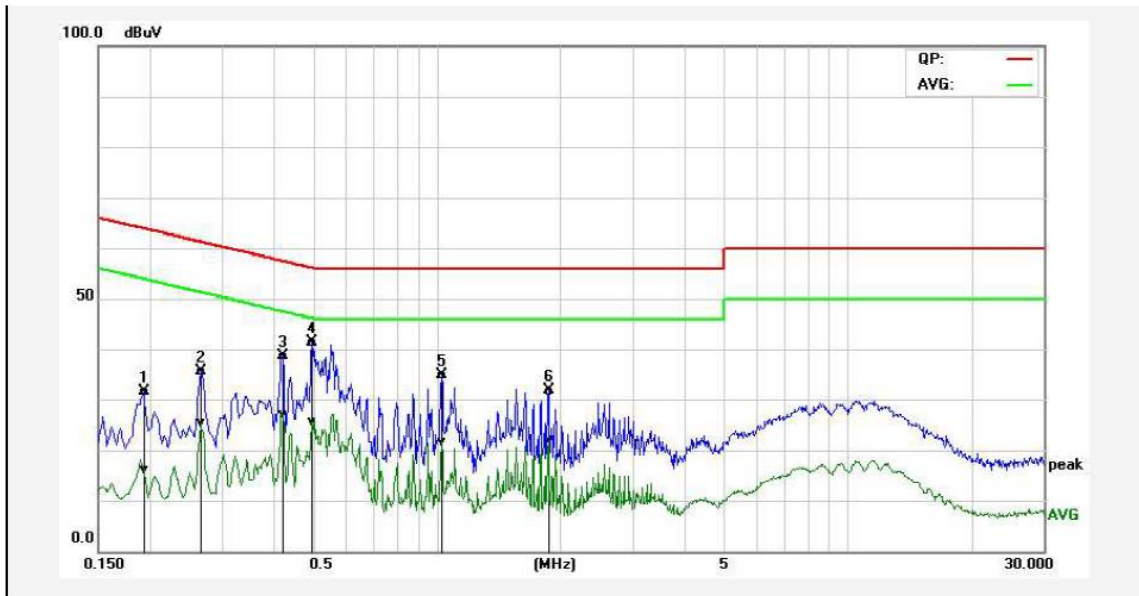

No.	Frequency (MHz)	QuasiPeak reading (dBuV)	Average reading (dBuV)	Correction factor (dB)	QuasiPeak result (dBuV)	Average result (dBuV)	QuasiPeak limit (dBuV)	Average limit (dBuV)	QuasiPeak margin (dB)	Average margin (dB)	Remark
1P	0.1940	21.54	6.10	10.08	31.62	16.18	63.86	53.86	-32.24	-37.68	Pass
2P	0.2660	25.59	15.21	10.06	35.65	25.27	61.24	51.24	-25.59	-25.97	Pass
3P	0.4220	28.54	17.12	10.05	38.59	27.17	57.41	47.41	-18.82	-20.24	Pass
4*	0.4980	31.35	15.57	10.05	41.40	25.62	56.03	46.03	-14.63	-20.41	Pass
5P	1.0300	24.74	11.41	10.11	34.85	21.52	56.00	46.00	-21.15	-24.48	Pass
6P	1.8700	21.62	11.97	10.13	31.75	22.10	56.00	46.00	-24.25	-23.90	Pass

Remark: Factor = Insertion Loss + Cable Loss, Result = Reading + Factor, Margin = Result – Limit.

Temperature:	24°C	Relative Humidity:	48%
Test Date:	Nov. 01, 2023	Pressure:	1010hPa
Test Voltage:	AC 120V, 60Hz	Phase:	Neutral
Test Mode:	Transmitting mode of GFSK 2440MHz		

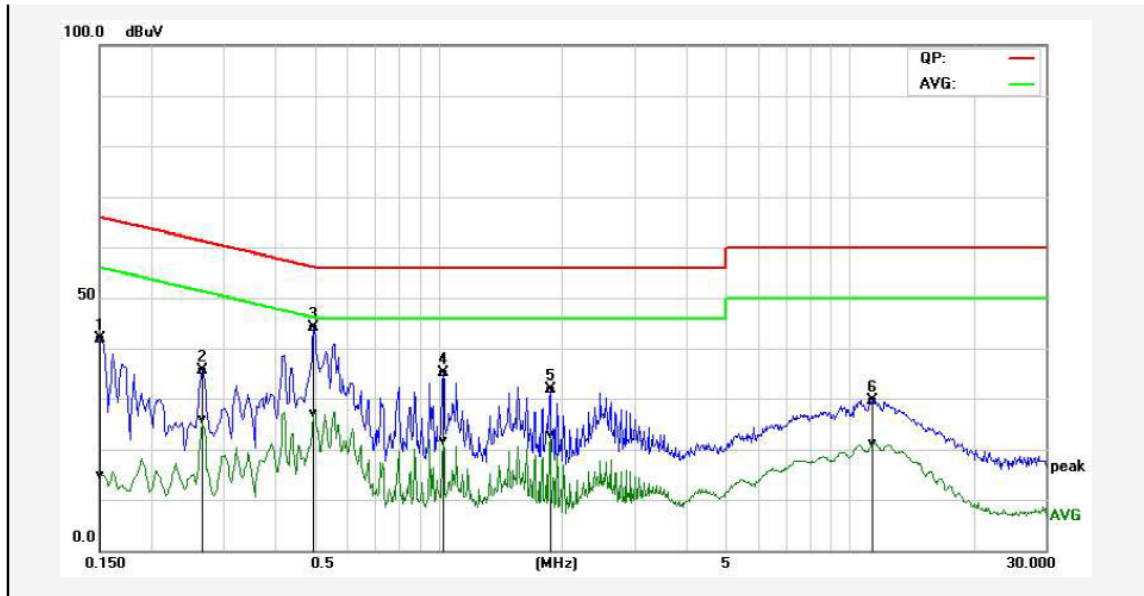

No.	Frequency (MHz)	QuasiPeak reading (dBuV)	Average reading (dBuV)	Correction factor (dB)	QuasiPeak result (dBuV)	Average result (dBuV)	QuasiPeak limit (dBuV)	Average limit (dBuV)	QuasiPeak margin (dB)	Average margin (dB)	Remark
1P	0.1500	31.83	4.75	10.05	41.88	14.80	65.99	56.00	-24.11	-41.20	Pass
2P	0.2660	25.67	15.83	10.06	35.73	25.89	61.24	51.24	-25.51	-25.35	Pass
3*	0.4980	34.05	17.02	10.05	44.10	27.07	56.03	46.03	-11.93	-18.96	Pass
4P	1.0300	25.02	11.63	10.11	35.13	21.74	56.00	46.00	-20.87	-24.26	Pass
5P	1.8700	21.63	12.67	10.13	31.76	22.80	56.00	46.00	-24.24	-23.20	Pass
6P	11.4340	19.19	10.63	10.52	29.71	21.15	60.00	50.00	-30.29	-28.85	Pass

Remark: Factor = Insertion Loss + Cable Loss, Result = Reading + Factor, Margin = Result – Limit.

4 RADIATED EMISSION

4.1 TEST LIMIT

For unintentional device, according to § 15.209(a), except for Class B digital devices, the field strength of radiated emissions from unintentional radiators at a distance of 3 meters shall not exceed the following values:

Frequency	Field strength (microvolt/meter)	Limit (dBuV/m)	Remark	Measurement distance (m)
0.009MHz-0.490MHz	2400/F (kHz)	-	Quasi-peak	300
0.490MHz-1.705MHz	24000/F (kHz)	-	Quasi-peak	30
1.705MHz-30MHz	30	-	Quasi-peak	30
30MHz-88MHz	100	40.0	Quasi-peak	3
88MHz-216MHz	150	43.5	Quasi-peak	3
216MHz-960MHz	200	46.0	Quasi-peak	3
960MHz-1GHz	500	54.0	Quasi-peak	3
Above 1GHz	500	54.0	Average	3
		74.0	Peak	3

For intentional device, according to § 15.209(a), the general requirement of field strength of radiated emissions from intentional radiators at a distance of 3 meters shall not exceed the above table.

Limit: (Field strength of the fundamental signal)

Frequency	Limit (dBuV/m @3m)	Remark
2400MHz-2483.5MHz	94.0	Average Value
	114.0	Peak Value

4.2 TEST SETUP

1. Radiated Emission Test-Up Frequency Below 30MHz

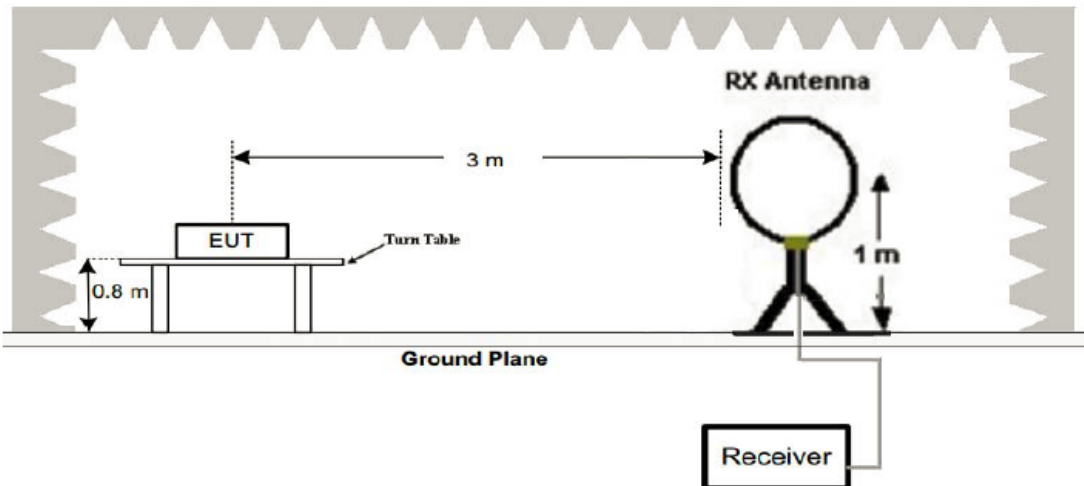

2. Radiated Emission Test-Up Frequency 30MHz~1GHz

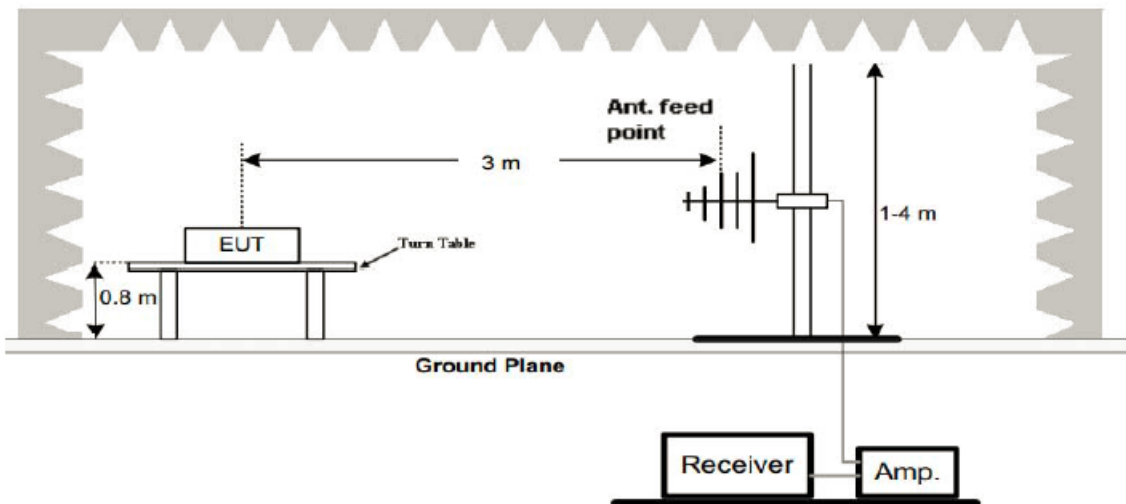

3. Radiated Emission Test-Up Frequency Above 1GHz

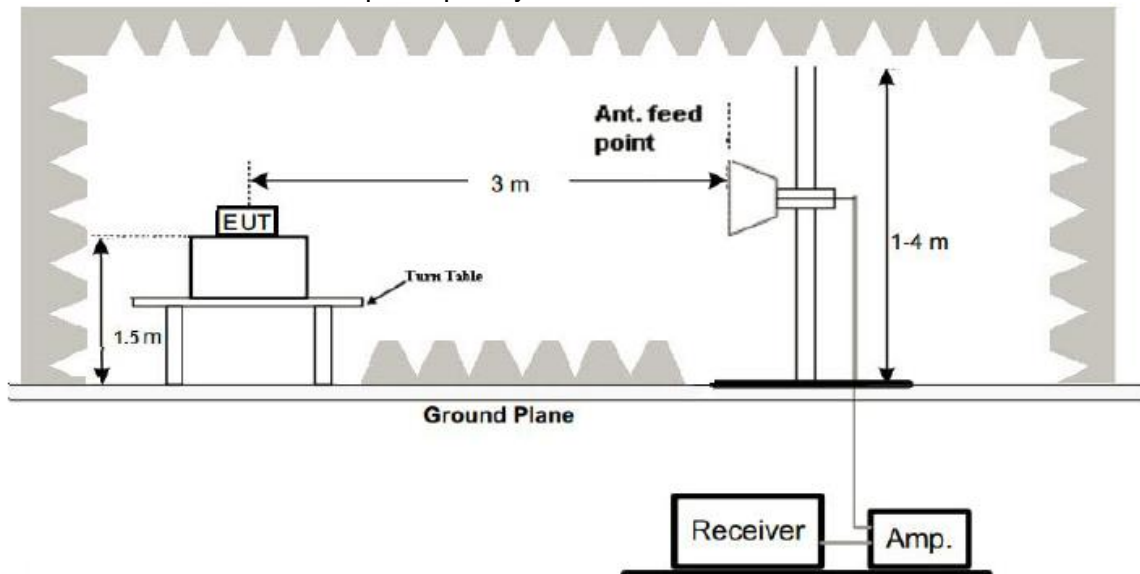

4.3 TEST PROCEDURE

1. Below 1GHz measurement the EUT is placed on turntable which is 0.8m above ground plane. And above 1GHz measurement EUT was placed on low permittivity and low tangent turn table which is 1.5m above ground plane.
2. The turntable shall be rotated for 360 degrees to determine the position of maximum emission level.
3. EUT is set 3m away from the receiving antenna, which is varied from 1m to 4m to find out the highest emissions.
4. Maximum procedure was performed on the six highest emissions to ensure EUT compliance.
5. And also, each emission was to be maximized by changing the polarization of receiving antenna both horizontal and vertical.
6. Repeat above procedures until the measurements for all frequencies are complete.
7. The test frequency range from 9kHz to 25GHz per FCC PART 15.33(a).

Note: For battery operated equipment, the equipment tests shall be performed using a new battery.

4.4 TEST RESULT

PASS

Remark:

1. All modes were test at Low, Middle, and High channel, only the worst result of GFSK Middle Channel was reported for below 1GHz test.
2. By preliminary testing and verifying three axis (X, Y and Z) position of EUT transmitted status, it was found that "X axis" position was the worst, and test data recorded in this report.
3. Radiated emission test from 9kHz to 10th harmonic of fundamental was verified, and no emission found except system noise floor in 9kHz to 30MHz and not recorded in this report.

Below 1GHz Test Results:

Temperature:	24°C	Relative Humidity:	48%
Test Date:	Nov. 01, 2023	Pressure:	1010hPa
Test Voltage:	AC 120V, 60Hz	Phase:	Horizontal
Test Mode:	Transmitting mode of GFSK 2440MHz		

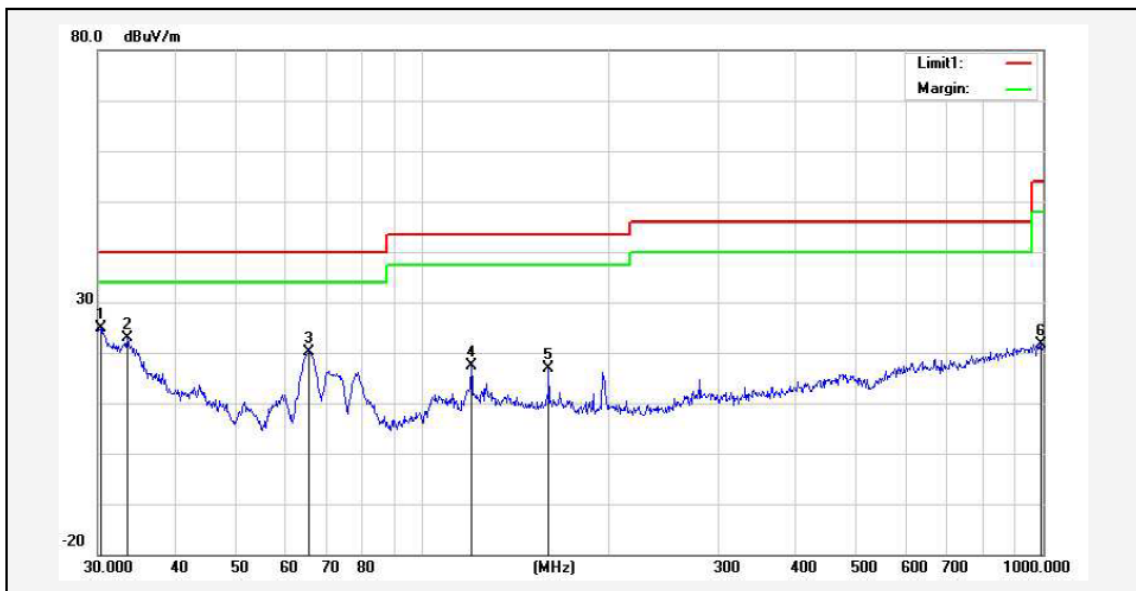

No.	Frequency (MHz)	Reading (dBuV)	Correction factor(dB/m)	Result (dBuV/m)	Limit (dBuV/m)	Margin (dB)	Degree (deg.)	Height (cm)	Remark
1*	30.3173	31.86	-7.10	24.76	40.00	-15.24	85	100	peak
2	33.4449	32.24	-9.43	22.81	40.00	-17.19	228	100	peak
3	65.5727	40.68	-20.56	20.12	40.00	-19.88	116	100	peak
4	119.8556	32.35	-15.06	17.29	43.50	-26.21	68	100	peak
5	159.7844	32.08	-15.27	16.81	43.50	-26.69	25	100	peak
6	993.0114	23.16	-1.50	21.66	54.00	-32.34	74	100	peak

Remark: Result = Reading Level + Factor, Margin = Result – Limit
 Factor = Ant. Factor + Cable Loss – Pre-amplifier

Temperature:	24°C	Relative Humidity:	48%
Test Date:	Nov. 01, 2023	Pressure:	1010hPa
Test Voltage:	AC 120V, 60Hz	Phase:	Vertical
Test Mode:	Transmitting mode of GFSK 2440MHz		

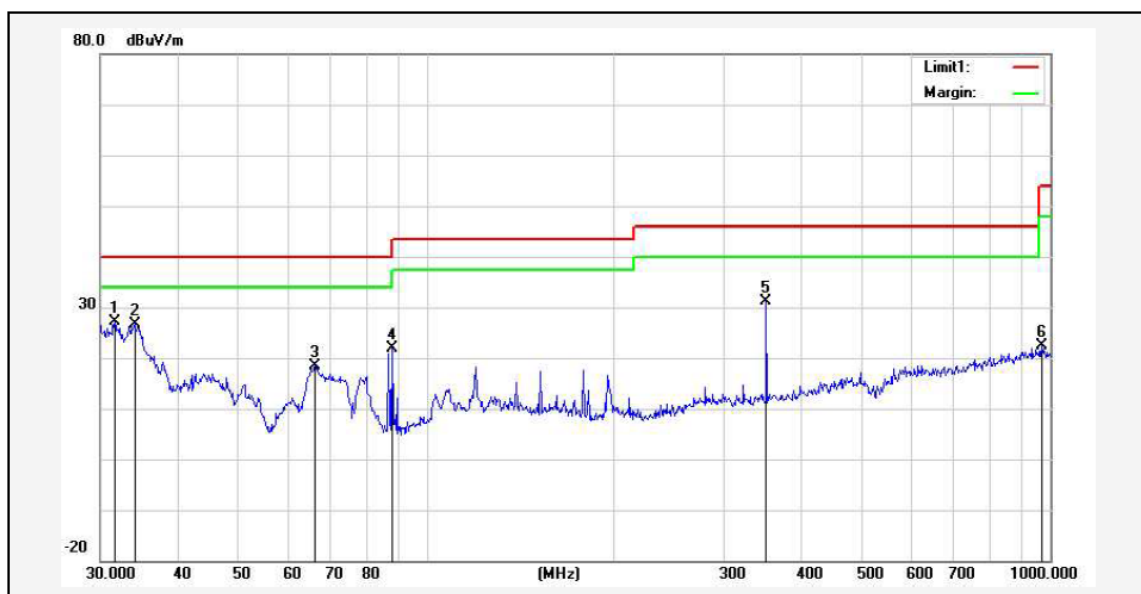

No.	Frequency (MHz)	Reading (dBuV)	Correction factor(dB/m)	Result (dBuV/m)	Limit (dBuV/m)	Margin (dB)	Degree (deg.)	Height (cm)	Remark
1*	31.6202	35.61	-8.55	27.06	40.00	-12.94	105	100	peak
2	34.0364	36.92	-10.35	26.57	40.00	-13.43	173	100	peak
3	66.2661	39.70	-21.25	18.45	40.00	-21.55	209	100	peak
4	88.0328	42.62	-20.80	21.82	43.50	-21.68	39	100	peak
5	350.4768	44.82	-13.75	31.07	46.00	-14.93	84	100	peak
6	968.9338	27.52	-5.22	22.30	54.00	-31.70	55	100	peak

Remark: Result = Reading Level + Factor, Margin = Result – Limit
 Factor = Ant. Factor + Cable Loss – Pre-amplifier

Remark:

1. Measuring frequencies from 9 kHz to the 1 GHz, Radiated emission test from 9kHz to 30MHz was verified, and no any emission was found except system noise floor.
2. * denotes emission frequency which appearing within the Restricted Bands specified in provision of 15.205, then the general radiated emission limits in 15.209 apply.
3. The IF bandwidth of EMI Test Receiver between 30MHz to 1GHz was 120kHz, 1 MHz for measuring above 1 GHz, below 30MHz was 10kHz.

Above 1 GHz Test Results:

CH00 (2402MHz)

Horizontal:

Frequency	Reading Result	Factor	Emission Level	Limits	Margin	Detector Type
(MHz)	(dB μ V)	(dB)	(dB μ V/m)	(dB μ V/m)	(dB)	
2402	99.81	-5.84	93.97	114	-20.03	PK
2402	79.26	-5.84	73.42	94	-20.58	AV
4804	56.49	-3.64	52.85	74	-21.15	PK
4804	36.37	-3.64	32.73	54	-21.27	AV
7206	53.36	-0.95	52.41	74	-21.59	PK
7206	33.06	-0.95	32.11	54	-21.89	AV

Remark: Factor = Antenna Factor + Cable Loss – Pre-amplifier. Margin = Emission Level – Limit

Vertical:

Frequency	Reading Result	Factor	Emission Level	Limits	Margin	Detector Type
(MHz)	(dB μ V)	(dB)	(dB μ V/m)	(dB μ V/m)	(dB)	
2402	99.45	-5.84	93.61	114	-20.39	PK
2402	79.15	-5.84	73.31	94	-20.69	AV
4804	56.52	-3.64	52.88	74	-21.12	PK
4804	36.26	-3.64	32.62	54	-21.38	AV
7206	53.15	-0.95	52.2	74	-21.8	PK
7206	32.68	-0.95	31.73	54	-22.27	AV

Remark: Factor = Antenna Factor + Cable Loss – Pre-amplifier. Margin = Emission Level – Limit

CH19 (2440MHz)

Horizontal:

Frequency	Reading Result	Factor	Emission Level	Limits	Margin	Detector Type
(MHz)	(dB μ V)	(dB)	(dB μ V/m)	(dB μ V/m)	(dB)	
2440	100.12	-5.71	94.41	114	-19.59	PK
2440	79.85	-5.71	74.14	94	-19.86	AV
4880	57.08	-3.51	53.57	74	-20.43	PK
4880	36.96	-3.51	33.45	54	-20.55	AV
7320	53.95	-0.82	53.13	74	-20.87	PK
7320	33.65	-0.82	32.83	54	-21.17	AV

Remark: Factor = Antenna Factor + Cable Loss – Pre-amplifier. Margin = Emission Level – Limit

Vertical:

Frequency	Reading Result	Factor	Emission Level	Limits	Margin	Detector Type
(MHz)	(dB μ V)	(dB)	(dB μ V/m)	(dB μ V/m)	(dB)	
2440	99.94	-5.71	94.23	114	-19.77	PK
2440	79.64	-5.71	73.93	94	-20.07	AV
4880	57.01	-3.51	53.5	74	-20.5	PK
4880	36.75	-3.51	33.24	54	-20.76	AV
7320	53.64	-0.82	52.82	74	-21.18	PK
7320	33.17	-0.82	32.35	54	-21.65	AV

Remark: Factor = Antenna Factor + Cable Loss – Pre-amplifier. Margin = Emission Level – Limit

CH39 (2480MHz)

Horizontal:

Frequency (MHz)	Reading Result (dB μ V)	Factor (dB)	Emission Level (dB μ V/m)	Limits (dB μ V/m)	Margin (dB)	Detector Type
2480	99.69	-5.65	94.04	114	-19.96	PK
2480	79.1	-5.65	73.45	94	-20.55	AV
4960	56.42	-3.43	52.99	74	-21.01	PK
4960	36.3	-3.43	32.87	54	-21.13	AV
7440	53.29	-0.75	52.54	74	-21.46	PK
7440	32.99	-0.75	32.24	54	-21.76	AV

Remark: Factor = Antenna Factor + Cable Loss – Pre-amplifier. Margin = Emission Level – Limit

Vertical:

Frequency (MHz)	Reading Result (dB μ V)	Factor (dB)	Emission Level (dB μ V/m)	Limits (dB μ V/m)	Margin (dB)	Detector Type
2480	99.28	-5.63	93.65	114	-20.35	PK
2480	78.98	-5.65	73.33	94	-20.67	AV
4960	56.35	-3.43	52.92	74	-21.08	PK
4960	36.09	-3.43	32.66	54	-21.34	AV
7440	52.98	-0.75	52.23	74	-21.77	PK
7440	32.51	-0.75	31.76	54	-22.24	AV

Remark: Factor = Antenna Factor + Cable Loss – Pre-amplifier. Margin = Emission Level – Limit

Remark:

1. Measuring frequencies from 1 GHz to the 25 GHz.
2. "F" denotes fundamental frequency; "H" denotes spurious frequency. "E" denotes band edge frequency.
3. * denotes emission frequency which appearing within the Restricted Bands specified in provision of 15.205, then the general radiated emission limits in 15.209 apply.
4. Data of measurement within this frequency range shown "---" in the table above means the reading of emissions are attenuated more than 20dB below the permissible limits or the field strength is too small to be measured.
5. The IF bandwidth of EMI Test Receiver between 30MHz to 1GHz was 120kHz, 1 MHz for measuring above 1 GHz, below 30MHz was 10kHz. The resolution bandwidth of test receiver/spectrum analyzer is 1MHz and video bandwidth is 3MHz for peak measurement with peak detector at frequency above 1GHz. The resolution bandwidth of test receiver/spectrum analyzer is 1MHz and video bandwidth is 10Hz for Average measurement with peak detection at frequency above 1GHz.
6. When the test results of Peak Detected below the limits of Average Detected, the Average Detected is not need completed. For example: Top Channel at Fundamental 73.16dBuV/m(PK Value) <93.98(AV Limit), at harmonic 53.20 dBuV/m(PK Value) <54 dBuV/m(AV Limit), the Average Detected not need to completed.
7. For fundamental frequency, RBW >20dB BW, VBW>=3XRBW, PK detector for PK value, AV detector for AV value.

5 BAND EDGE

5.1 TEST LIMIT

FCC PART 15.249(d) Emissions radiated outside of the specified frequency bands, except for harmonics, shall be attenuated by at least 50 dB below the level of the fundamental or to the general radiated emission limits in §15.209, whichever is the lesser attenuation.

5.2 TEST SETUP

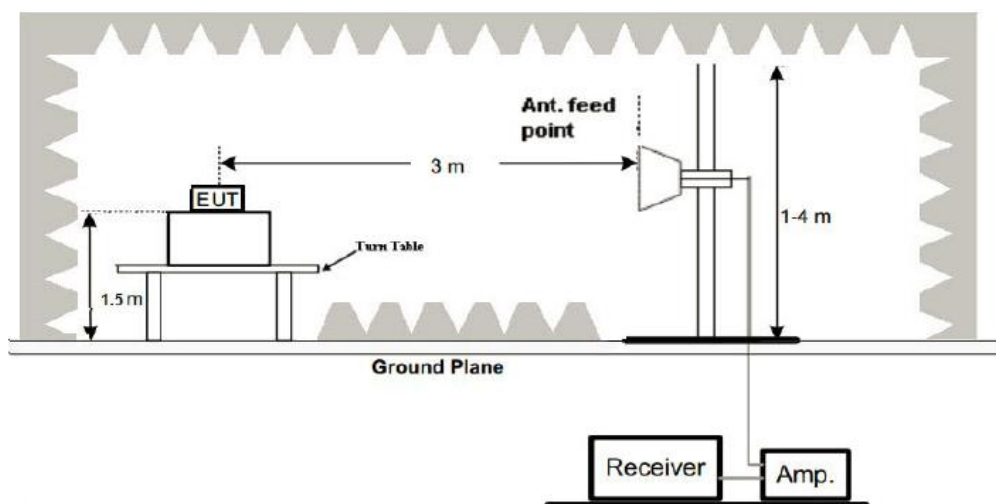

5.3 MEASUREMENT EQUIPMENT USED

Refer to Section 3.3.

5.4 TEST PROCEDURE

1. The EUT operates at transmitting mode. The operate channel is tested to verify the largest transmission and spurious emissions power at the continuous transmission mode. The band edge compliance of RF radiated emission should be measured by following the guidance in ANSI C63.10 with respect to maximizing the emission by rotating the EUT, measuring the emission while the EUT is situated in three orthogonal planes (if appropriate), adjusting the measurement antenna height and polarization etc.
2. Set the spectrum analyzer in the following setting in order to capture the lower and upper band-edges of the emission:
 - (a) PEAK: RBW=1MHz, VBW=3MHz / Sweep=AUTO
 - (b) AVERAGE: RBW=1MHz ; VBW=3MHz / Sweep=AUTO

5.5 TEST RESULT

PASS

Operation Mode: TX CH00 (2402MHz)

Horizontal:

Frequency	Reading Result	Factor	Emission Level	Limits	Margin	Detector
(MHz)	(dB μ V)	(dB)	(dB μ V/m)	(dB μ V/m)	(dB)	Type
2310	57.21	-5.81	51.4	74	-22.6	PK
2310	/	-5.81	/	54	/	AV
2390	57.33	-5.84	51.49	74	-22.51	PK
2390	/	-5.84	/	54	/	AV
2400	57.18	-5.84	51.34	74	-22.66	PK
2400	/	-5.84	/	54	/	AV

Remark: Factor = Antenna Factor + Cable Loss – Pre-amplifier.

Vertical:

Frequency	Reading Result	Factor	Emission Level	Limits	Margin	Detector
(MHz)	(dB μ V)	(dB)	(dB μ V/m)	(dB μ V/m)	(dB)	Type
2310	56.95	-5.81	51.14	74	-22.86	PK
2310	/	-5.81	/	54	/	AV
2390	57.12	-5.84	51.28	74	-22.72	PK
2390	/	-5.84	/	54	/	AV
2400	57.28	-5.84	51.44	74	-22.56	PK
2400	/	-5.84	/	54	/	AV

Remark: Factor = Antenna Factor + Cable Loss – Pre-amplifier.

Operation Mode: TX CH39 (2480MHz)

Horizontal:

Frequency	Reading Result	Factor	Emission Level	Limits	Margin	Detector
(MHz)	(dB μ V)	(dB)	(dB μ V/m)	(dB μ V/m)	(dB)	Type
2483.5	55.92	-5.65	50.27	74	-23.73	PK
2483.5	/	-5.65	/	54	/	AV
2500	57.04	-5.72	51.32	74	-22.68	PK
2500	/	-5.72	/	54	/	AV
Remark: Factor = Antenna Factor + Cable Loss – Pre-amplifier.						

Vertical:

Frequency	Reading Result	Factor	Emission Level	Limits	Margin	Detector
(MHz)	(dB μ V)	(dB)	(dB μ V/m)	(dB μ V/m)	(dB)	Type
2483.5	57.5	-5.65	51.85	74	-22.15	PK
2483.5	/	-5.65	/	54	/	AV
2500	57.01	-5.72	51.29	74	-22.71	PK
2500	/	-5.72	/	54	/	AV
Remark: Factor = Antenna Factor + Cable Loss – Pre-amplifier.						

Note:

1. Since the peak value is less than the average limit, the average value does not reflected in the report.

6 20dB Bandwidth

6.1 TEST SETUP (BLOCK DIAGRAM OF CONFIGURATION)

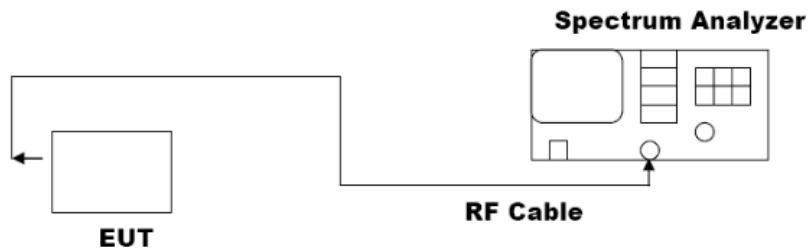

6.2 MEASUREMENT EQUIPMENT USED

Refer to Section 3.3.

6.3 TEST PROCEDURE

1. The RF output of EUT was connected to the spectrum analyzer by RF cable. The path loss was compensated to the results for each measurement.
2. Set to the maximum power setting and enable the EUT transmit continuously.
3. Make the measurement with the spectrum analyzer's resolution bandwidth (RBW) = 30 kHz. Set the Video bandwidth (VBW) = 100 kHz. In order to make an accurate measurement.
4. For 20dB Bandwidth Measurement, the spectrum analyzer's resolution bandwidth (RBW) is set 1-5% of the emission bandwidth and set the Video bandwidth (VBW) $\geq 3 * RBW$.
5. Measure and record the results in the test report.

6.4 TEST RESULT

PASS

GFSK Modulation:

Channel	Frequency (MHz)	20dB Bandwidth (MHz)	Result
CH00	2402	1.324	PASS
CH19	2440	1.281	PASS
CH39	2480	1.286	PASS

CH00: 2402MHz

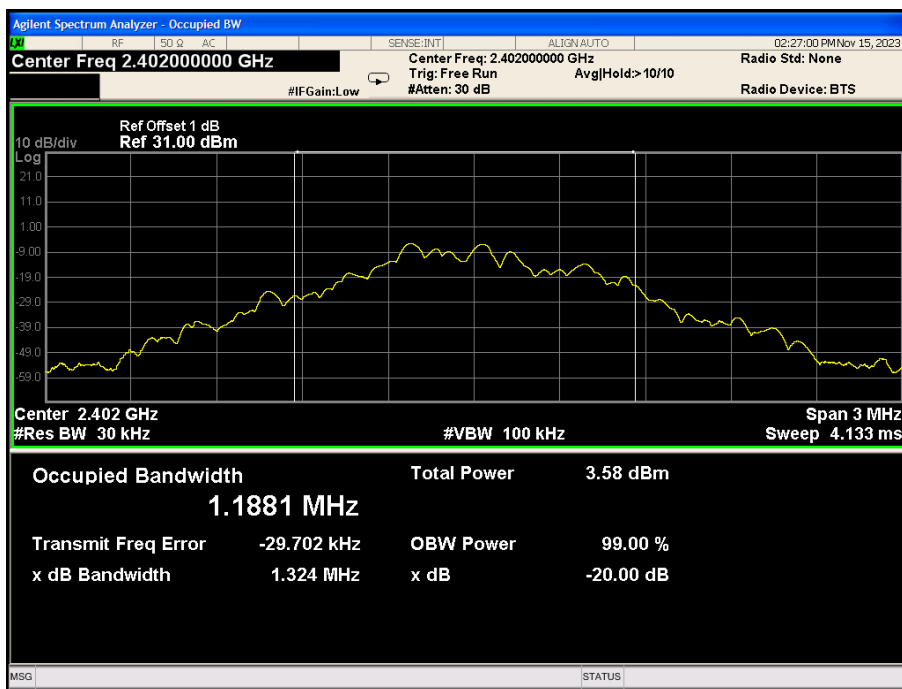

CH19: 2440MHz

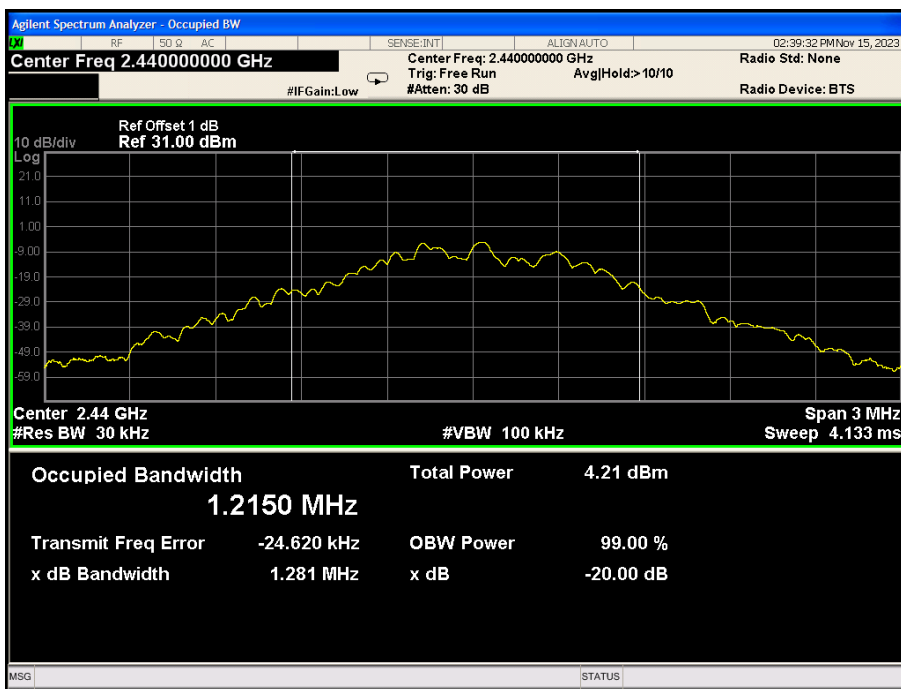

CH39: 2480MHz

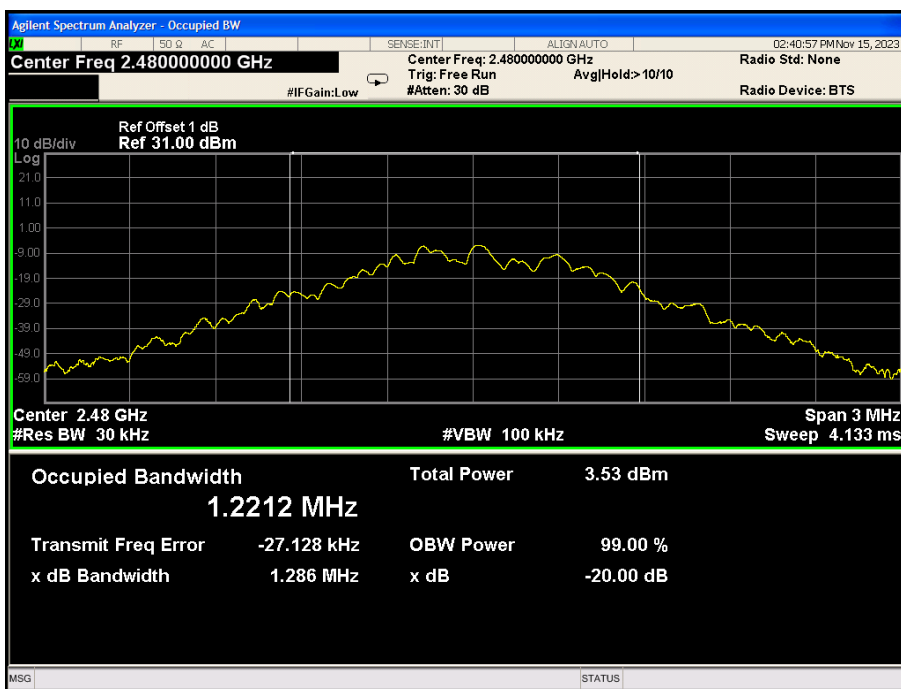

7 ANTENNA REQUIREMENT

Standard Applicable:

For intentional device, according to FCC 47 CFR Section 15.203, an intentional radiator shall be designed to ensure that no antenna other than that furnished by the responsible party shall be used with the device.

Antenna Conncted Construction

The antenna used in this product is a PCB Antenna, The directional gains of antenna used for transmitting is 0dBi.

ANTENNA:

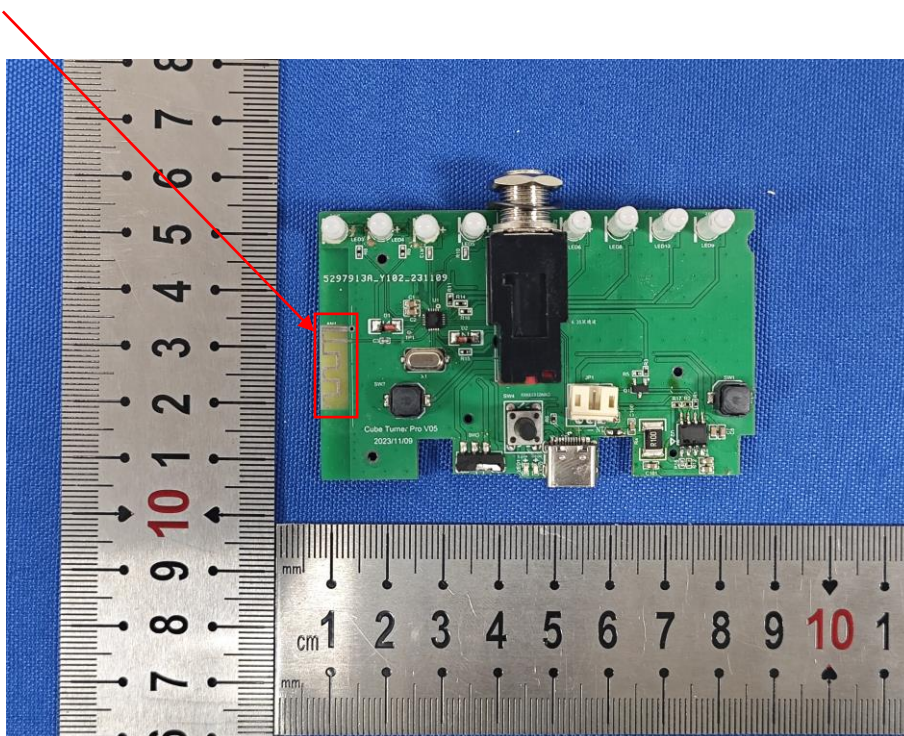

8 PHOTO OF TEST

RADIATED EMISSION

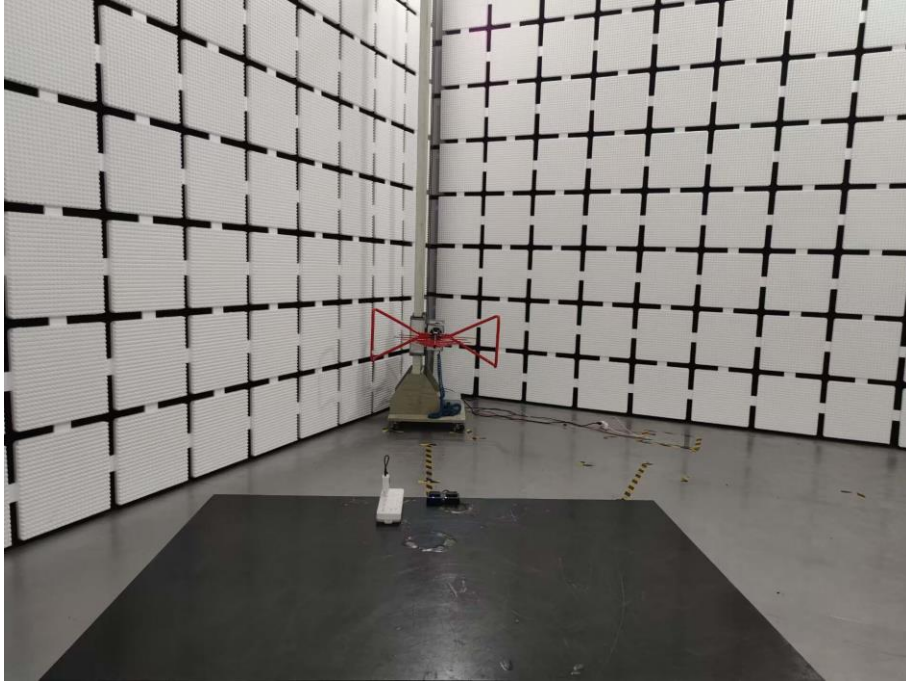

30MHz-1000MHz

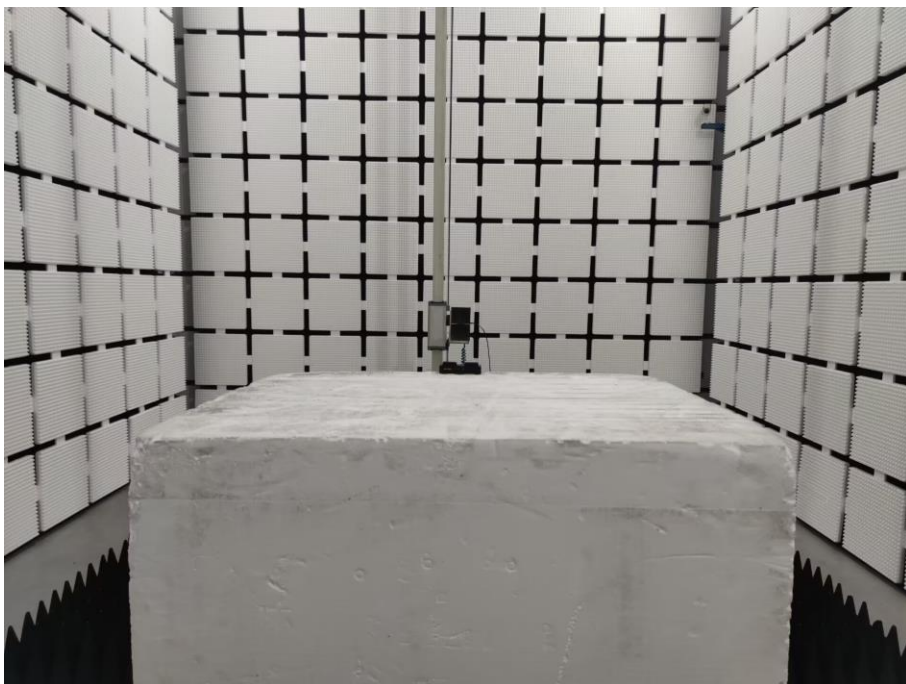

Above 1GHz

CONDUCTED EMISSION

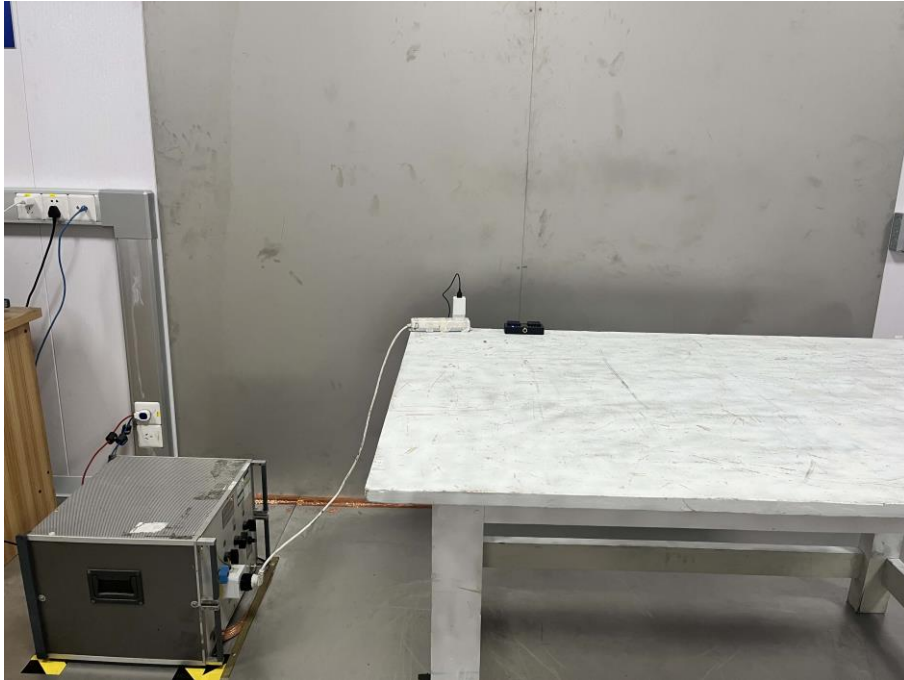

RF CONDUCTED

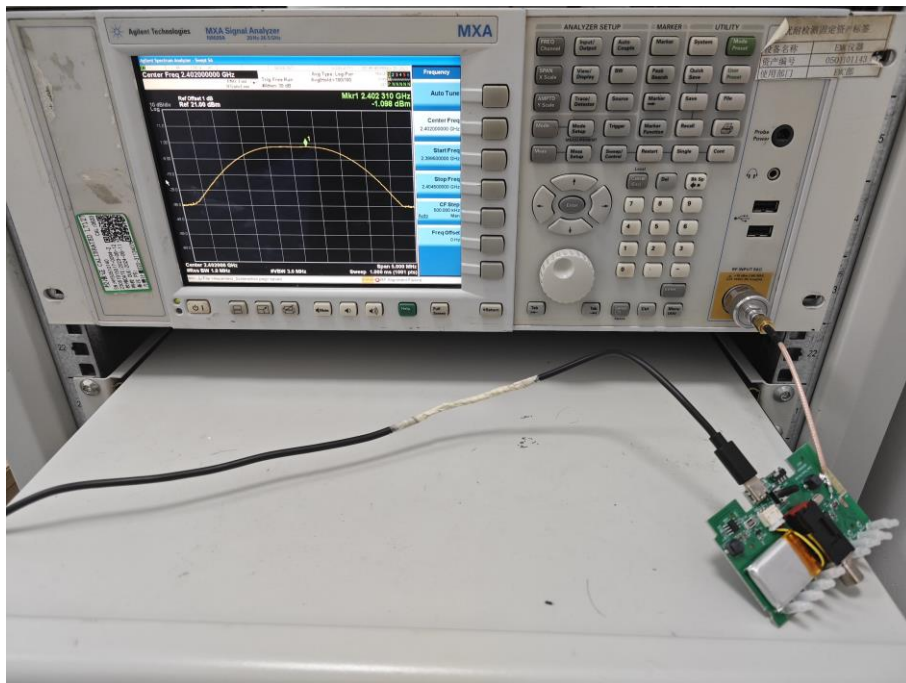

End of Report