

# INSTRUCTION MANUAL

## AIR PURIFIER



**Model No: KF-P22W**

**Keep these instructions for future reference**

**Read and save these instruction**

Thank you for purchasing the innovative KF-P22W air purifier. We wish you many ears of healthy indoor air with this efficient and effective product.

Ensure that all safety precautions are followed when using this air purifier for the proper operation of the device. These instructions describe the safety precautions to be observed during operation. They are designed to prevent injuries or damage to this device.

Changes or modifications to this unit not expressly approved by the party responsible for

compliance could void the user's authority to

### **SAFETY PRECAUTIONS:**

Caution Marking:

1. CAUTION: HIGH VOLTAGE.

2. CAUTION: DO NOT DEFEAT INTERLOCK

ATTENTION : NE PAS NUIRE À L'ACTION DU VERROUILLAGE DE SÉCURITÉ.

3. WARNING: DISCONNECT POWER SUPPLY BEFORE SERVICING

AVERTISSEMENT : COUPER L'ALIMENTATION AVANT DE PROCÉDER AU DÉPANNAGE.

4. CAUTION: THIS EQUIPMENT SHOULD BE INSPECTED AND COLLECTOR CELLS SHOULD BE CLEANED IN ACCORDANCE WITH THE MANUFACTURER'S INSTRUCTIONS ON A REGULAR BASIS TO PREVENT EXCESSIVE ACCUMULATION OF DUST PARTICLES THAT CAN RESULT IN FLASHOVER OR A RISK OF FIRE.

ATTENTION : CET APPAREIL DEVRAIT FAIRE L'OBJET D'UNE INSPECTION ET LES FILTRES DEVRAIENT ÊTRE NETTOYÉS CONFORMÉMENT AUX INSTRUCTIONS DU FABRICANT, DE FAÇON RÉGULIÈRE, AFIN D'EMPÊCHER UNE ACCUMULATION EXCESSIVE DE POUSSIÈRE POUVANT PROVOQUER UN EMBRASEMENT ÉCLAIR OU CAUSER UN RISQUE D'INCENDIE.

5. CAUTION: DISCONNECT POWER FROM ASSEMBLY BEFORE SERVICING OR REPLACING UV LAMP

ATTENTION : COUPER L'ALIMENTATION DE L'ASSEMBLAGE AVANT DE PROCÉDER AU DÉPANNAGE OU REMPLACEMENT DU LAMPE UV.

6. WARNING - Skin or eye damage may result from directly viewing the light produced by the lamp in this apparatus. Always disconnect power before relamping or servicing.

7. The 8-hr TWA Ozone for this product is XX ppmv when tested in a 30 m<sup>3</sup> chamber  
Refer to safety instructions in manual for more information

**NOTE:** This equipment has been tested and found to comply with the limits for a Class B digital device, pursuant to Part 15 of the FCC Rules. These limits are designed to provide reasonable protection against harmful interference in a residential installation. This equipment generates uses and can radiate radio frequency energy and, if not installed and used in accordance with the instructions, may cause harmful interference to radio communications.

However, there is no guarantee that interference will not occur in a particular installation. If this equipment does cause harmful interference to radio or television reception, which can be determined by turning the equipment off and on, the user is encouraged to try to correct the interference by one or more of the following measures:

- Reorient or relocate the receiving antenna.
- Increase the separation between the equipment and receiver.
- Connect the equipment into an outlet on a circuit different from that to which the receiver is connected.
- Consult the dealer or an experienced radio/TV technician for help.

## 1. READ AND SAVE THESE INSTRUCTIONS

2. RISK OF ELECTRIC SHOCK – These servicing instructions are for use by qualified personnel only. To reduce the risk of electric shock, do not perform any servicing other than that contained in the operating instructions unless you are qualified to do so.
3. A product shall include a means to manually disconnect, disable or override any remote operation commands, external communication or data signals. If the product attachment plug and receptacle serve as the manual means to disconnect data signals or remote operation commands, shall specify that unplugging the product disconnects the remote functions in instruction.
4. WARNING - Skin or eye damage may result from directly viewing the light produced by the lamp in this apparatus. Always disconnect power before relamping or servicing.
5. Cleaning the unit, while it is plugged in may result in electric shock, electric spark and serious injury. Unplug the unit before cleaning or maintenance.
6. WARNING : To Reduce The Risk Of Fire Or Electric Shock, Do Not Use This Fan With Any Solid-State Speed Control Device.
7. This product complies with the maximum allowable concentration of ozone of 0.050 parts per million by volume (ppmv) in a 24-h period.”

1. Our air purifier is used Adapter power supply.
2. Cleaning the unit, while it is plugged in may result in electric shock, electric spark and serious injury. Unplug the unit before cleaning or maintenance.
3. This air purifier contains a UV-Bemitter.
4. Unintended use of the air purifier or damage to the housing may result in the escape of dangerous UV-B radiation UV-B radiation may, even in little doses, cause harm to the eves and skin.
5. Air purifier are obviously damaged must not be operated.
6. According to the working environment, the device needs to be cleaned within 2-4 weeks. Before cleaning, unplug the device, open the back cover, remove the filter, wipe the interior of the device with a wet towel.
7. If the UV light is damaged, it must be replaced by the manufactures, its service agent, or similarly qualified persons in order to avoid a hazard.

WARING: To reduce the risk of fire, electric shock or injury, read and understand this user guide before operation this air purifier.

1. The air purifier is not to be used by persons (including children) with reduced physical, sensory or mental capabilities, or lack of experience and knowledge, unless they have been given supervision or instruction. Children being supervised not to play with the air purifier. (For Others)
2. This air purifier can be used by children aged from 8 years and above and persons with reduced physical, sensory or mental capabilities or lack of experience and knowledge if they have been given supervision or instruction concerning use of the air purifier in a safe way and understand the hazards involved. Children shall not play with the air purifier. Cleaning and user maintenance

shall not be made by children without supervision. (For Europe)

3. If the supply cord is damaged, it must be replaced by the manufacturer, its service agent or similarly qualified persons in order to avoid a hazard.
4. Do not operate unit if cord or plug is damaged. Doing so can result in electric shock. Discard the damaged unit or take it to an authorized service facility for examination and /or repair.
5. Do not run cord under carpeting. Do not cover cord with throw rugs, runners or similar coverings. **DO NOT ROUTE CORD UNDER FURNITURE OR AIR PURIFIER.** Arrange cord away from traffic area and where it will not be tripped over.
6. Only use the air purifier as described in this manual.
7. Do not handle the unit with wet hands. Thoroughly dry your hands before handling any part of the air purifier.
8. Hair, loose clothing and body parts can get caught in the air purifier resulting in injury. Keep hair, loose clothing and body parts away from openings and moving parts.
9. Do not unplug by pulling on the cord. Doing so may result in electrical spark or fire, unplug the unit by grasping. And pulling the plug.
10. Do not use an extension cord.
11. Do not place the air purifier near sources of heat, such as: stove tops, ovens, radiators or computers.
12. Unplug the air purifier from the power supply before servicing.
13. This equipment should be inspected frequently and the dirt that has collected should be removed regularly to prevent excessive accumulation that may result in flash over or fire.
14. Do not use the air purifier outdoors or on wet surfaces.
15. Do not use the air purifier in an enclosed space where flammable, combustible or explosive gases are present.
16. Do not use in an area where toxic vapors, flammable dust or oxygen tanks are present. Check the location and make sure these elements are not present.
17. Do not place open flames, including candles, directly in front of the air purifier.
18. It is important to keep all objects away from the air intake grille.
19. Place the air purifier on a flat, solid, stable surface. Never place the unit on soft surfaces such as a bed or sofa.
20. Position the air purifier so that the dirty air is not drawn across your head or body while sitting or sleeping.
21. Children should be supervised when product is in use. Do not allow children to play on or near the air purifier. Keep children's hair, loose clothing, and body parts away from/ out of the intake grille, vents, holes, or openings.

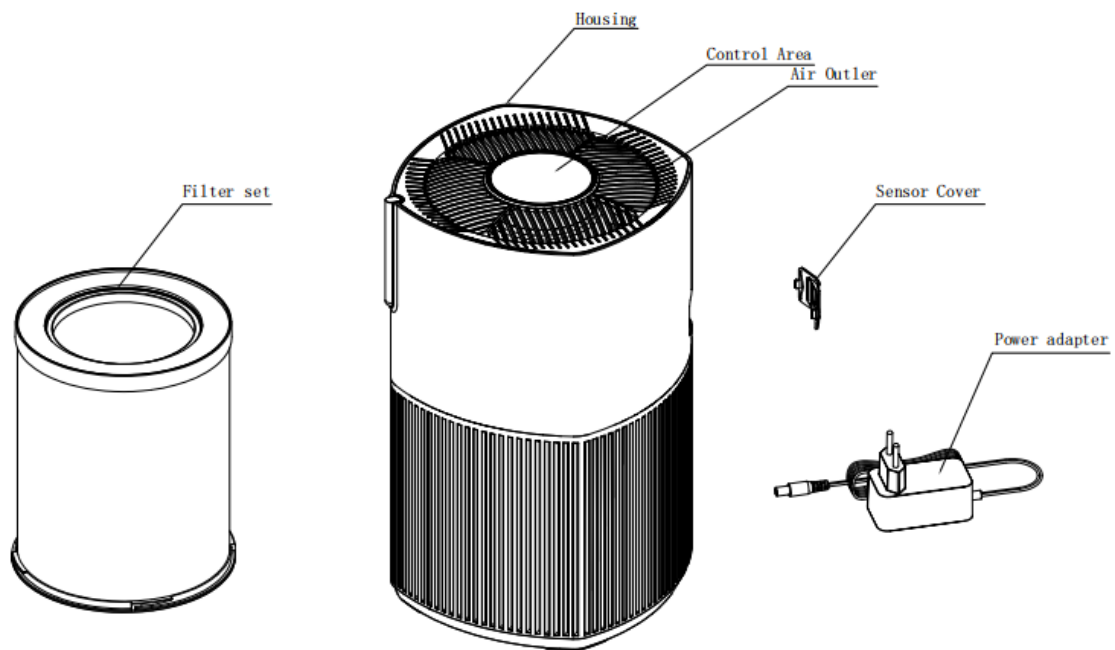

## **PRODUCT DIAGRAM:**





**FEATURES AND OPERATION:**







**Instructions for usage**



**Power:** When plug in, display will be on for 1 second and a beep sound will be heard. The  "Power" button will be shown and  "WIFI" icon (for WIFI version only) will flash (it will always be on after connecting to the App in mobile phone), then the air purifier keep in standby state.



Touch  "Power" button, air purifier starts up and the air quality indicator around the screen alternates between green, yellow, orange and red. Display shows symbol  which means the air purifier is working in Auto Mode with medium speed. PM2.5 value "000" is flashing at the beginning and 10 seconds later it begins to show air quality in real-time data. Air quality indicator shows air quality in the corresponding color and air purifier will adjust the speed according to the air quality automatically per 1 minute.



Auto Mode Chart			
Color	Air Quality	PM2.5 Data	Fan Speed
Red	Bad	> 151	3 (High)
Orange	Moderate	101~150	2
Yellow	Good	51~100	1
Green	Very Good	< 50	Lower 1

**Speed:** Touch  "Speed" button air purifier will exit the Auto Mode. Cycles through fan speeds:  speed 1,  speed 2,  speed 3 and then  Auto Mode.

The fan speed cannot be changed during Sleep mode.

**Timer:** Touch  "Timer" button, "--" icon flashes in display. Touch the button continually to set the timer from 1~12 hours, after choosing desired timer, display is flashing timer 3 times and switch to show PM2.5 data, it means setting is done, display show  icon. It calculates by counting down every hour. When the time is up, the air purifier shuts down. Touch the button till icon "--" or long press the button for 2 seconds to cancel timer setting. In the timing function, touch the timing button again can check the remaining time.





**ION/UV:** Touch  "ION/UV" button to turn on the Anion function with according icon  show. Touch the button again to turn on UV function with according icon  show. Touch the third time to turn off Anion function. Touch fourth time to turn off the UV function.

**Sleep:** Touch  "Sleep" button, the air purifier will enter Sleep Mode. Sleep Mode uses the lowest possible fan speed (even lower than "lower 1" speed) to create a quite environment. Display only shows the icon  with 1\3 brightness. Touch any button to illumine the display in 1\3 brightness, then you can operate other functions. If 15 seconds without any operation, display show the icon  with 1\3 brightness only again. Touch again to turn back to Auto Mode.

**Display turn off function:** Long press  "Sleep" button for 2 seconds to turn off the display. Touch any button to illumine the display in 1\3 brightness, and then press it to operate other functions. 15 seconds without any operation, display turns off again. Long press this button to exit display turn off function.

When turn off display in the sleep mode, the "sleep" button is in bright pink. Otherwise, the "s"Sleep" button is in bright red.

## **FILTER CHANGE**



When air purifier working hours reach to 3000H, the filter change indicator icon  in the display flashing  red to remind user change filter till filter changed. After filter is changed, touch  button, display will be on for 1 second and then in standby mode. At the moment, touch  "Power" button to switch on the air purifier.

## **PROTECTION**

The air purifier has protection function. When the filter cover is removed or not installed well, the air purifier will automatic cut off.

## **WIFI OPERATION INSTRUCTION:**

1. Download "Tuya Smart" from App store. After installment, register by E-mail or mobile number, and then follow below steps.

2. Long press  "Power" button for about 3 seconds (or long press for about 6 seconds to enter AP mode), display shows WIFI icon  and keep twinkling. It means the air purifier has entered the network state successfully. (If you long press this button for about 10 seconds, the air purifier will exit the connection with the mobile APP).

3. Enter App, add corresponding device and then follow the operation as App indicated.

4. When the App is connected to the air purifier successfully, the WIFI icon  on the screen will be on, and then the App can control the air purifier.

This equipment complies with FCC radiation exposure limits set forth for an uncontrolled environment. This equipment should be installed and operated with a minimum distance of 20cm between the radiator & your body. This transmitter must not be co-located or operating in conjunction with any other antenna or transmitter.

## **AROMA BOX**

1. Draw out aroma box from the top part.
2. Use water-soluble aroma oil and drop on to the sponge.

3. Put the aroma box back into device, the aroma function will remain on when the device is running.
4. To stop the aroma function or when storing the device, clean the sponge in the aroma box.
5. Only drop aroma oil into aroma cotton.



**MAINTENANCE:**

After using period of time, dust on the sensor will affect its sensitivity. We suggest clean it every two months. But time can be shortened or extended according to indoor environment.

**HOW TO CLEAN THE DUST SENSOR:**

Unplug then open the dust sensor cover, and dip the cotton swab in clean water. Clean the lens with cotton swab. Then wipe the lens with dry cotton swab to make it dry.

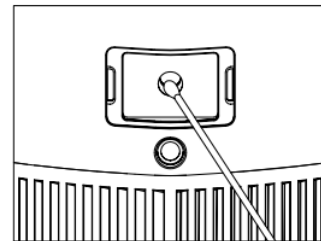
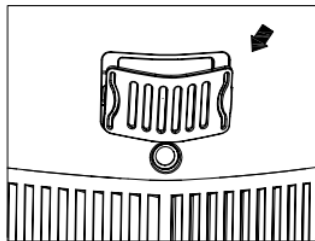
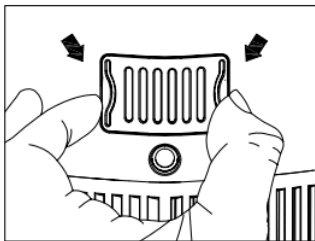

**TOUBLESHOOTING:**

If your air purifier is not working correctly, please check the following causes:

Trouble	Possible reasons	Shooting Way
---------	------------------	--------------



<b>No power</b>	Fault in power source	Switch on when the power source get regular
<b>Not working</b>	Plug not connected Fault in electric circuit	Insert the plug again Try again in other place
<b>Unusual noise</b>	There is foreign body in the air purifier	Take to service center.
	Dirty filter	Replace the filter

#### **TECHNICAL SPECIFICATIONS:**

1. Input voltage: AC 120V-240V
2. Frequency: 50/60Hz
3. Consumption power: 22W
4. Applicable area: 20m<sup>2</sup>
5. Noise level: ≤50dB
  1. CADR: 82CFM (199m<sup>3</sup>/H)
  2. Operating condition: Temperature: 10°C~45°C
  3. Humidity: ≤95%RH

#### **WARRANTY AND SERVICE:**

**WE GUARANTEE THE UNIT TO BE FREE FROM DEFECTS IN MATERIAL OR WORKMANSHIP FOR A PERIOD OF ONE (1) YEAR FROM THE DATE OF PURCHASE.**

Should this unit be operated under conditions other than those recommended or at voltages other than the voltage indicated on the unit, or any attempts made to service or modify the unit, this will render WARRANTY VOID. The product you buy may sometimes differ slightly from illustration.



**DISPOSAL:** Do not dispose this product as unsorted municipal waste. Collection of such waste separately for special treatment is necessary.