

FCC RADIO TEST REPORT

FCC ID: 2AR9I-ZGV300

Product : iTalkBB Chinese TV

Trade Name : iTalkBB

Model Name : IBT-ZGV300

Serial Model : N/A

Report No. : UNIA19022504FR-03

Prepared for

Beijing Net263 Network Technology LTD.

16th Floor, JIANDA Building, No.14 Dongtucheng Road, Chaoyang District,
Beijing, 100103, China

Prepared by

Shenzhen United Testing Technology Co., Ltd.

2F, Annex Bldg, Jiahuangyuan Tech Park, #365 Baotian 1 Rd, Tiegang
Community, Xixiang Str, Bao'an District, Shenzhen, China

TEST RESULT CERTIFICATION

Applicant's name.....: Beijing Net263 Network Technology LTD.
Address.....: 16th Floor, JIANDA Building, No.14 Dongtucheng Road,
Chaoyang District, Beijing, 100103, China

Manufacture's Name.....: Beijing Net263 Network Technology LTD.
Address.....: 16th Floor, JIANDA Building, No.14 Dongtucheng Road,
Chaoyang District, Beijing, 100103, China

Product description

Product name.....: iTalkBB Chinese TV

Trade Mark.....: iTalkBB

Model and/or type reference ..: IBT-ZGV300

Standards.....: FCC Rules and Regulations Part 15 Subpart C Section 15.247
ANSI C63.10: 2013

This device described above has been tested by Shenzhen United Testing Technology Co., Ltd., and the test results show that the equipment under test (EUT) is in compliance with the FCC requirements. And it is applicable only to the tested sample identified in the report.

This report shall not be reproduced except in full, without the written approval of UNI, this document may be altered or revised by Shenzhen United Testing Technology Co., Ltd., personnel only, and shall be noted in the revision of the document.

Date of Test.....:

Date (s) of performance of tests.....: Jan. 11~23, 2019

Date of Issue.....: Jan. 24, 2019

Test Result.....: Pass

Prepared by:

Kahn yang/Editor

Reviewer:

Sherwin Qian/Supervisor

Approved & Authorized Signer:

Liuze/Manager

Table of Contents	Page
1. TEST SUMMARY.....	5
1.1 TEST PROCEDURES AND RESULTS.....	5
1.2 TEST FACILITY.....	5
1.3 MEASUREMENT UNCERTAINTY.....	5
2. GENERAL INFORMATION.....	6
2.1 GENERAL DESCRIPTION OF EUT.....	6
2.2 Carrier Frequency of Channels.....	7
2.3 Operation of EUT during testing.....	7
2.4 DESCRIPTION OF TEST SETUP.....	7
2.5 MEASUREMENT INSTRUMENTS LIST.....	8
3. CONDUCTED EMISSIONS TEST.....	9
3.1 Conducted Power Line Emission Limit.....	9
3.2 Test Setup.....	9
3.3 Test Procedure.....	9
3.4 Test Result.....	9
4. RADIATED EMISSION TEST.....	12
4.1 Radiation Limit.....	12
4.2 Test Setup.....	12
4.3 Test Procedure.....	13
4.4 Test Result.....	13
5. BAND EDGE.....	28
5.1 Limits.....	28
5.2 Test Procedure.....	28
5.3 Test Result.....	28
6. OCCUPIED BANDWIDTH MEASUREMENT.....	30
6.1 Test Limit.....	30
6.2 Test Procedure.....	30
6.3 Measurement Equipment Used.....	30
6.4 Test Result.....	30
7. POWER SPECTRAL DENSITY TEST.....	35
7.1 Test Limit.....	35
7.2 Test Procedure.....	35
7.3 Measurement Equipment Used.....	35

Table of Contents

Page

7.4 Test Result.....	35
8. PEAK OUTPUT POWER TEST.....	40
8.1 Test Limit.....	40
8.2 Test Procedure.....	40
8.3 Measurement Equipment Used.....	40
8.4 Test Result.....	40
9. OUT OF BAND EMISSIONS TEST.....	41
9.1 Test Limit.....	41
9.2 Test Procedure.....	41
9.3 Test Setup.....	41
9.4 Test Result.....	41
10. SPURIOUS RF CONDUCTED EMISSION.....	46
10.1 Test Limit.....	46
10.2 Test Procedure.....	46
10.3 Test Setup.....	46
10.4 Test Result.....	46
11. ANTENNA REQUIREMENT.....	50
12. PHOTOGRAPH OF TEST.....	51

1. TEST SUMMARY

1.1 TEST PROCEDURES AND RESULTS

DESCRIPTION OF TEST	RESULT
CONDUCTED EMISSIONS TEST	COMPLIANT
RADIATED EMISSION TEST	COMPLIANT
BAND EDGE	COMPLIANT
OCCUPIED BANDWIDTH MEASUREMENT	COMPLIANT
POWER SPECTRAL DENSITY	COMPLIANT
PEAK OUTPUT POWER	COMPLIANT
CONDUCTED BANDEGE MEASUREMENT	COMPLIANT
SPURIOUS RF CONDUCTED EMISSION	COMPLIANT
ANTENNA REQUIREMENT	COMPLIANT

1.2 TEST FACILITY

Test Firm : Shenzhen United Testing Technology Co., Ltd.
 Address : 2F, Annex Bldg, Jiahuangyuan Tech Park, #365 Baotian 1 Rd, Tiegang Community, Xixiang Str, Bao'an District, Shenzhen, China

The testing quality ability of our laboratory meet with "Quality Law of People's Republic of China" Clause 19. The testing quality system of our laboratory meets with ISO/IEC-17025 requirements, which is approved by CNAS. This approval result is accepted by MRA of APLAC.

Our test facility is recognized, certified, or accredited by the following organizations:

CNAS-LAB Code: L6494

The EMC Laboratory has been assessed and in compliance with CNAS-CL01 accreditation criteria for testing Laboratories (identical to ISO/IEC 17025:2017 General Requirements) for the Competence of testing Laboratories.

Designation Number: CN1227

Test Firm Registration Number: 674885

The EMC Laboratory has been registered and fully described in a report filed with the (FCC) Federal Communications commission. The acceptance letter from the FCC is maintained in our files.

1.3 MEASUREMENT UNCERTAINTY

Measurement Uncertainty

Conducted Emission Expanded Uncertainty	= 2.23dB, k=2
Radiated emission expanded uncertainty(9kHz-30MHz)	= 3.08dB, k=2
Radiated emission expanded uncertainty(30MHz-1000MHz)	= 4.42dB, k=2
Radiated emission expanded uncertainty(Above 1GHz)	= 4.06dB, k=2

2. GENERAL INFORMATION

2.1 GENERAL DESCRIPTION OF EUT

Equipment	iTalkBB Chinese TV
Trade Mark	iTalkBB
Model Name	IBT-ZGV300
Serial No.	N/A
Model Difference	N/A
FCC ID	2AR9I-ZGV300
Antenna Type	Internal Antenna
Antenna Gain	Antenna A: 2.0dBi Antenna B: 2.0dBi
Directional Gain	$2.0+10*\log(2)=5.01\text{dBi}$
Frequency Range	802.11b/g/n20: 2412~2462 MHz 802.11n(HT40):2422~2452MHz
Number of Channels	802.11b/g/n20: 11CH 802.11n(HT40):7
Modulation Type	CCK, OFDM, DBPSK, DAPSK
Power Source	DC 12V from Adapter
Adapter Information	Manufacturer: SHENZHEN FRECOM ELECTRONICS CO., LTD Model: F12L19-120100SPAU Input: AC 100-240V, 50/60Hz, 0.3A Output: DC 12V/1A

Table for auxiliary equipment:

Equipment Description	Manufacturer	Model	Calibration Due Date
Notebook	Lenovo	Lenovo G475	GB14477457

2.2 Carrier Frequency of Channels

Channel List for 802.11b/g/n(20MHz)							
Channel	Frequency (MHz)	Channel	Frequency (MHz)	Channel	Frequency (MHz)	Channel	Frequency (MHz)
01	2412	04	2427	07	2442	10	2457
02	2417	05	2432	08	2447	11	2462
03	2422	06	2437	09	2452		

2.3 Operation of EUT during testing

Operating Mode

The mode is used: Transmitting mode for 802.11b/g/n(20MHz)/n(40MHz)

Low Channel: 2412MHz/2422MHz

Middle Channel: 2437MHz

High Channel: 2462MHz/2452MHz

Test SW Version: WLAN Test

2.4 DESCRIPTION OF TEST SETUP

Operation of EUT during Conducted testing:

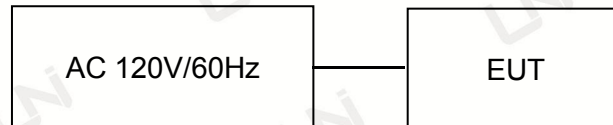

Operation of EUT during Radiation and Above1GHz Radiation testing:

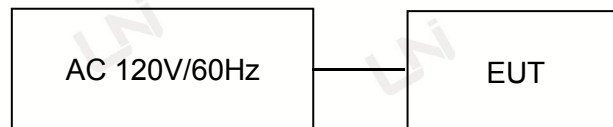

2.5 MEASUREMENT INSTRUMENTS LIST

Item	Equipment	Manufacturer	Model No.	Serial No.	Calibrated until
CONDUCTED EMISSIONS TEST					
1	AMN	Schwarzbeck	NNLK8121	8121370	2019.9.9
2	AMN	ETS	3810/2	00020199	2019.9.9
3	EMI TEST RECEIVER	Rohde&Schwarz	ESCI	101210	2019.9.9
4	AAN	TESEQ	T8-Cat6	38888	2019.9.9
RADIATED EMISSION TEST					
1	Horn Antenna	Sunol	DRH-118	A101415	2019.9.29
2	BicoNILog Antenna	Sunol	JB1 Antenna	A090215	2019.9.29
3	PREAMP	HP	8449B	3008A00160	2019.9.9
4	PREAMP	HP	8447D	2944A07999	2019.9.9
5	EMI TEST RECEIVER	Rohde&Schwarz	ESR3	101891	2019.9.9
6	VECTOR Signal Generator	Rohde&Schwarz	SMU200A	101521	2019.9.28
7	Signal Generator	Agilent	E4421B	MY4335105	2019.9.28
8	MXA Signal Analyzer	Agilent	N9020A	MY50510140	2019.9.28
9	MXA Signal Analyzer	Agilent	N9020A	MY51110104	2019.9.9
10	ANT Tower&Turn table Controller	Champro	EM 1000	60764	2019.9.28
11	Anechoic Chamber	Taihe Maorui	9m*6m*6m	966A0001	2019.9.9
12	Shielding Room	Taihe Maorui	6.4m*4m*3m	643A0001	2019.9.9
13	RF Power sensor	DARE	RPR3006W	15I00041SNO88	2019.3.14
14	RF Power sensor	DARE	RPR3006W	15I00041SNO89	2019.3.14
15	RF power divider	Anritsu	K241B	992289	2019.9.28
16	Wideband radio communication tester	Rohde&Schwarz	CMW500	154987	2019.9.28
17	Biconical antenna	Schwarzbeck	VHA 9103	91032360	2019.9.8
18	Biconical antenna	Schwarzbeck	VHA 9103	91032361	2019.9.8
19	Broadband Hybrid Antennas	Schwarzbeck	VULB9163	VULB9163#958	2019.9.8
20	Horn Antenna	Schwarzbeck	BBHA9120D	9120D-1680	2019.1.12
21	Active Receive Loop Antenna	Schwarzbeck	FMZB 1919B	00023	2019.9.8
22	Horn Antenna	Schwarzbeck	BBHA 9170	BBHA9170651	2019.03.14
23	Microwave Broadband Preampifier	Schwarzbeck	BBV 9721	100472	2019.9.8
24	Active Loop Antenna	Com-Power	AL-130R	10160009	2019.05.10
25	Power Meter	KEYSIGHT	N1911A	MY50520168	2019.05.10
26	Frequency Meter	VICTOR	VC2000	997406086	2019.05.10
27	DC Power Source	HYELEC	HY5020E	055161818	2019.05.10
Test software					
1	E3	Audix	6.101223a	N/A	N/A

3. CONDUCTED EMISSIONS TEST

3.1 Conducted Power Line Emission Limit

For unintentional device, according to § 15.107(a) Line Conducted Emission Limits is as following

Frequency (MHz)	Maximum RF Line Voltage(dBμV)			
	CLASS A		CLASS B	
	Q.P.	Ave.	Q.P.	Ave.
0.15~0.50	79	66	66~56*	56~46*
0.50~5.00	73	60	56	46
5.00~30.0	73	60	60	50

* Decreasing linearly with the logarithm of the frequency

For intentional device, according to §15.207(a) Line Conducted Emission Limit is same as above table.

3.2 Test Setup

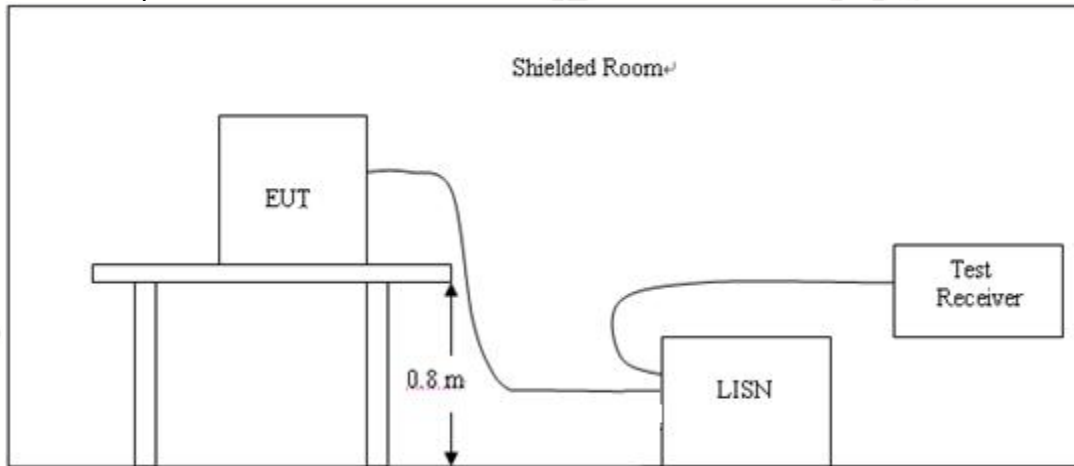

3.3 Test Procedure

- 1, The equipment was set up as per the test configuration to simulate typical actual usage per the user's manual. A wooden table with a height of 0.8 meters is used and is placed on the ground plane as per ANSI C63.10.
- 2, Support equipment, if needed, was placed as per ANSI C63.10.
- 3, All I/O cables were positioned to simulate typical actual usage as per ANSI C63.10.
- 4, If a EUT received DC power from the USB Port of Notebook PC, the PC's adapter received AC120V/60Hz power through a Line Impedance Stabilization Network (LISN) which supplied power source and was grounded to the ground plane.
- 5, All support equipments received AC power from a second LISN, if any.
- 6, The EUT test program was started. Emissions were measured on each current carrying line of the EUT using a spectrum Analyzer / Receiver connected to the LISN powering the EUT. The LISN has two monitoring points: Line 1 (Hot Side) and Line 2 (Neutral Side). Two scans were taken: one with Line 1 connected to Analyzer / Receiver and Line 2 connected to a 50 ohm load; the second scan had Line 1 connected to a 50 ohm load and Line 2 connected to the Analyzer / Receiver.
- 7, Analyzer / Receiver scanned from 150 KHz to 30MHz for emissions in each of the test modes.

3.4 Test Result

Pass

Remark:

1. All modes were tested at AC 120V and 240V, only the worst result of AC 120V was reported.
2. Remark: We tested at 802.11b/802.11g/802.11n HT20/802.11n HT40 mode at the antenna single and recored the worst data 802.11b mode for Antenna B in report.

Temperature:	24°C	Relative Humidity:	48%
Test Date:	Jan. 14, 2019	Pressure:	1010hPa
Test Voltage:	AC 120V, 60Hz	Phase:	Line
Test Mode:	Transmitting 802.11b mode for Antenna B		

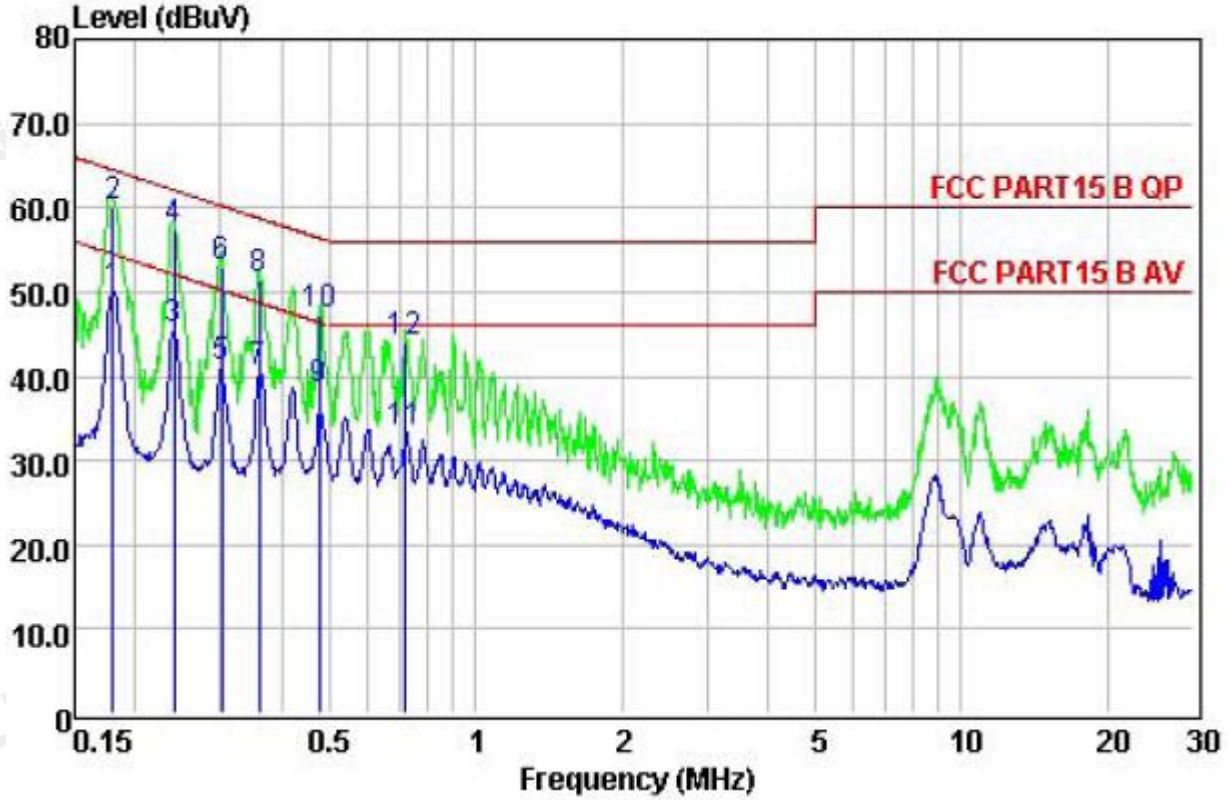

	Freq	Level	LISN Factor	Limit Line	Over Limit	Remark
	MHz	dBuV	dB	dBuV	dB	
1	0.18	50.04	9.66	54.50	-4.46	Average
2	0.18	60.20	9.66	64.50	-4.30	QP
3	0.24	45.56	9.63	52.08	-6.52	Average
4	0.24	57.40	9.63	62.08	-4.68	QP
5	0.30	40.95	9.61	50.24	-9.29	Average
6	0.30	52.80	9.61	60.24	-7.44	QP
7	0.36	40.57	9.60	48.74	-8.17	Average
8	0.36	51.40	9.60	58.74	-7.34	QP
9	0.48	38.22	9.58	46.36	-8.14	Average
10	0.48	47.20	9.58	56.36	-9.16	QP
11	0.72	33.19	9.61	46.00	-12.81	Average
12	0.72	43.90	9.61	56.00	-12.10	QP

Remark: Factor = Insertion Loss + Cable Loss, Result = Reading + Factor, Margin = Result – Limit.

Temperature:	24°C	Relative Humidity:	48%
Test Date:	Jan. 14, 2019	Pressure:	1010hPa
Test Voltage:	AC 120V, 60Hz	Phase:	Neutral
Test Mode:	Transmitting 802.11b mode for Antenna B		

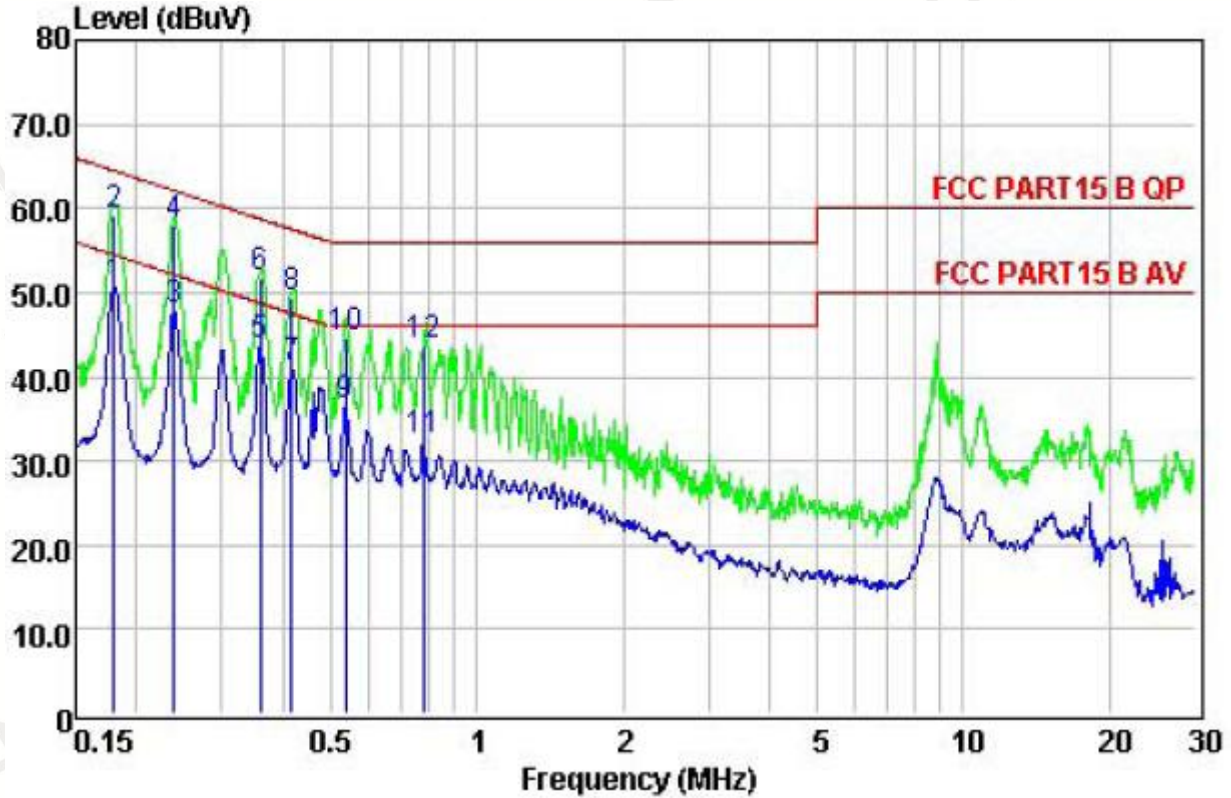

	Freq	Level	LISN Factor	Limit Line	Over Limit	Remark
	MHz	dBuV	dB	dBuV	dB	
1	0.18	50.61	9.53	54.50	-3.89	Average
2	0.18	59.20	9.53	64.50	-5.30	QP
3	0.24	47.90	9.57	52.13	-4.23	Average
4	0.24	58.10	9.57	62.13	-4.03	QP
5	0.36	43.68	9.58	48.74	-5.06	Average
6	0.36	51.60	9.58	58.74	-7.14	QP
7	0.42	40.91	9.59	47.51	-6.60	Average
8	0.42	49.40	9.59	57.51	-8.11	QP
9	0.54	36.48	9.59	46.00	-9.52	Average
10	0.54	44.60	9.59	56.00	-11.40	QP
11	0.78	32.38	9.60	46.00	-13.62	Average
12	0.78	43.80	9.60	56.00	-12.20	QP

Remark: Factor = Insertion Loss + Cable Loss, Result = Reading + Factor, Margin = Result – Limit.

4. RADIATED EMISSION TEST

4.1 Radiation Limit

For unintentional device, according to § 15.109(a), except for Class A digital devices, the field strength of radiated emissions from unintentional radiators at a distance of 3 meters shall not exceed the following values:

Frequency (MHz)	Distance (Meters)	Radiated (dB μ V/m)	Radiated (μ V/m)
30-88	3	40	100
88-216	3	43.5	150
216-960	3	46	200
Above 960	3	54	500

For intentional device, according to § 15.209(a), the general requirement of field strength of radiated emissions from intentional radiators at a distance of 3 meters shall not exceed the above table.

4.2 Test Setup

1. Radiated Emission Test-Up Frequency Below 30MHz

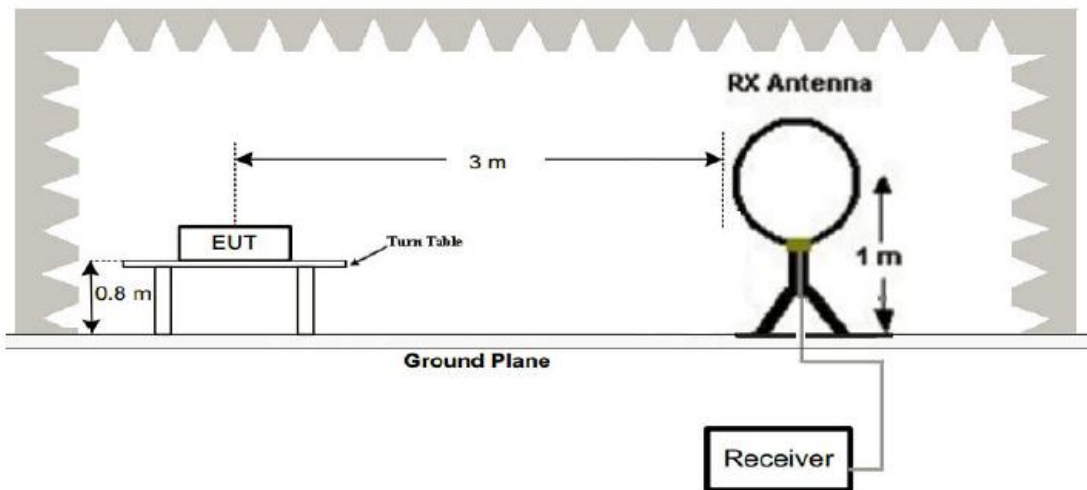

2. Radiated Emission Test-Up Frequency 30MHz~1GHz

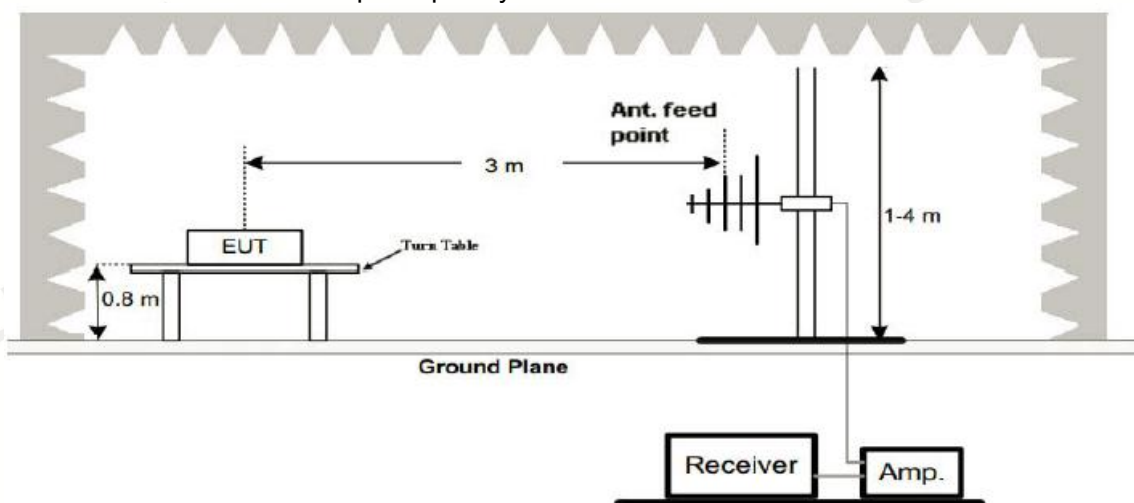

3. Radiated Emission Test-Up Frequency Above 1GHz

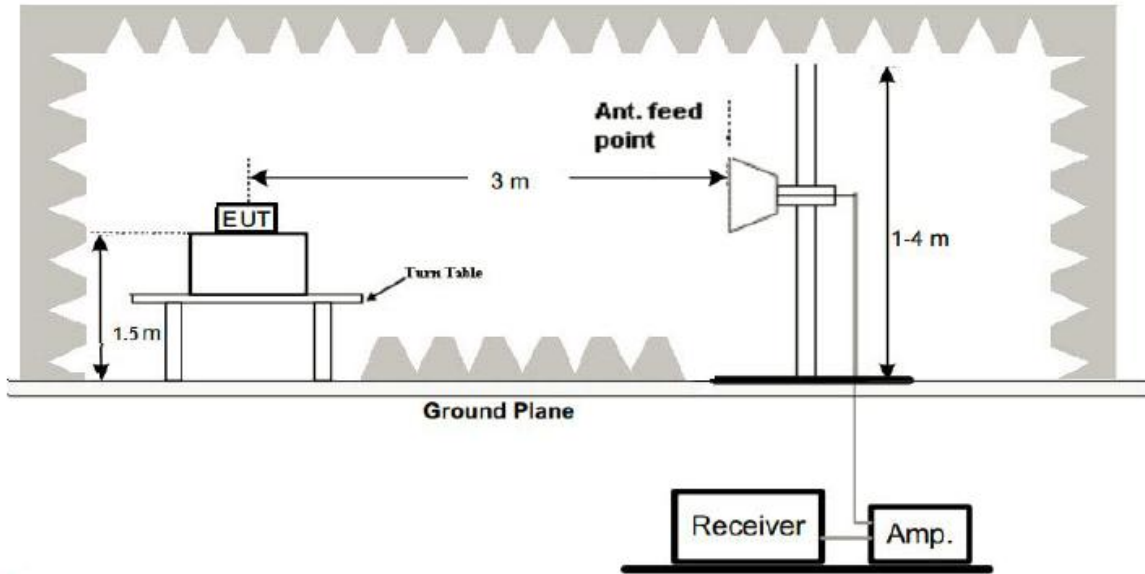

4.3 Test Procedure

1. Below 1GHz measurement the EUT is placed on turntable which is 0.8m above ground plane. And above 1GHz measurement EUT was placed on low permittivity and low tangent turn table which is 1.5m above ground plane.
2. The turntable shall be rotated for 360 degrees to determine the position of maximum emission level.
3. EUT is set 3m away from the receiving antenna, which is varied from 1m to 4m to find out the highest emissions.
4. Maximum procedure was performed on the six highest emissions to ensure EUT compliance.
5. And also, each emission was to be maximized by changing the polarization of receiving antenna both horizontal and vertical.
6. Repeat above procedures until the measurements for all frequencies are complete.
7. The test frequency range from 9KHz to 25GHz per FCC PART 15.33(a).
8. The distance between test antenna and EUT as following table states:

Test Frequency range	Test Antenna Type	Test Distance
9KHz-30MHz	Active Loop Antenna	3
30MHz-1GHz	Bilog Antenna	3
1GHz-18GHz	Horn Antenna	3
18GHz-25GHz	Horn Antenna	1

Note:

For battery operated equipment, the equipment tests shall be performed using a new battery.

4.4 Test Result

PASS

Remark:

1. All modes of 802.11b/g/n20 were test at Low, Middle, and High channel, only the worst result of 802.11b Low Channel was reported for below 1GHz test.
2. Remark: We tested at 802.11b/802.11g/802.11n HT20/802.11n HT40 mode at the antenna single and recored the worst data 802.11b mode for Antenna B in report.

Below 1GHz Test Results:

Temperature:	22°C	Relative Humidity:	48%
Test Date:	Jan. 14, 2019	Pressure:	1010hPa
Test Voltage:	AC 120V, 60Hz	Polarization:	Horizontal
Test Mode:	Transmitting 802.11b mode for Antenna B		

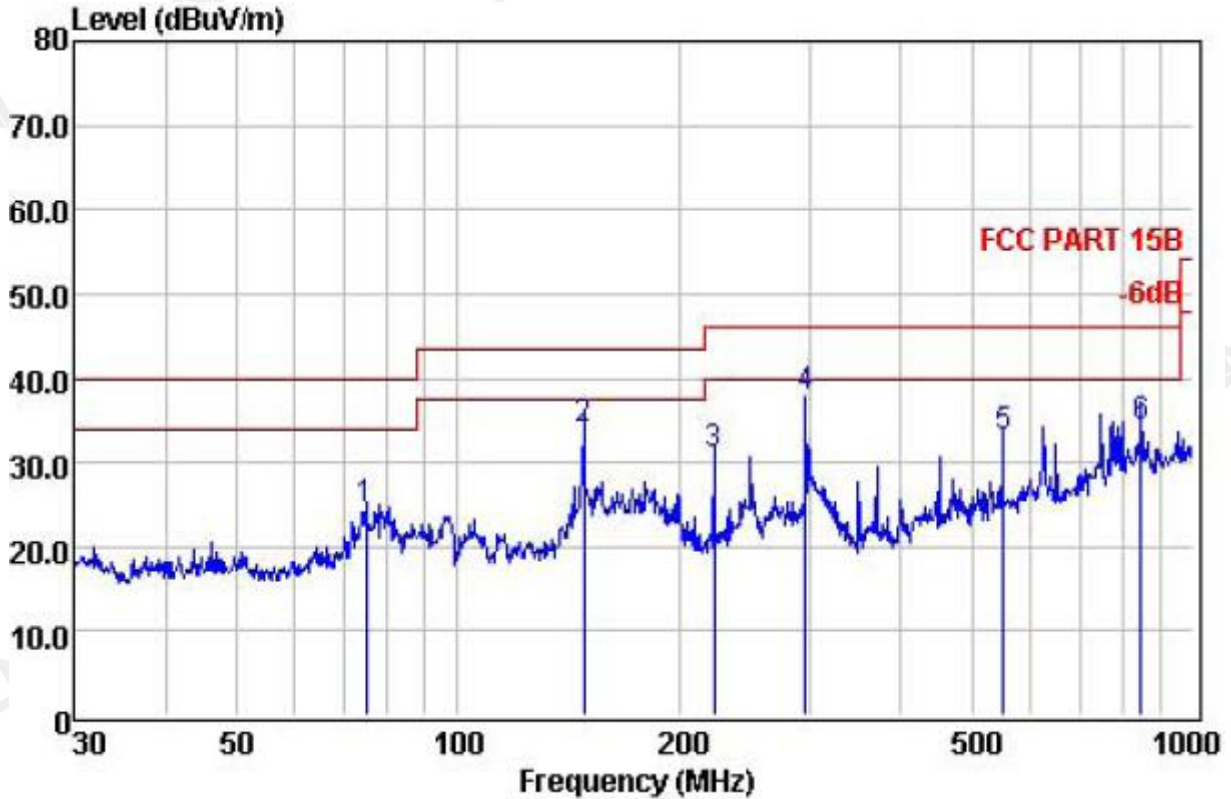

	Freq	Read Level	Antenna Factor	Cable Loss	Level	Limit	Over Limit	Remark
	MHz	dBuV	dB/m	dB	dBuV/m	dBuV/m	dB	
1	74.92	11.33	12.95	0.15	24.43	40.00	-15.57	QP
2	148.44	18.27	15.42	0.23	33.92	43.50	-9.58	QP
3	222.95	18.83	11.64	0.40	30.87	46.00	-15.13	QP
4	297.22	24.14	12.85	0.64	37.63	46.00	-8.37	QP
5	550.95	14.44	17.54	1.16	33.14	46.00	-12.86	QP
6	851.04	10.66	21.89	1.52	34.07	46.00	-11.93	QP

Remark: Absolute Level = Reading Level + Factor, Margin = Absolute Level – Limit
 Factor = Ant. Factor + Cable Loss – Pre-amplifier

Temperature:	22°C	Relative Humidity:	48%
Test Date:	Jan. 14, 2019	Pressure:	1010hPa
Test Voltage:	AC 120V, 60Hz	Polarization:	Vertical
Test Mode:	Transmitting 802.11b mode for Antenna B		

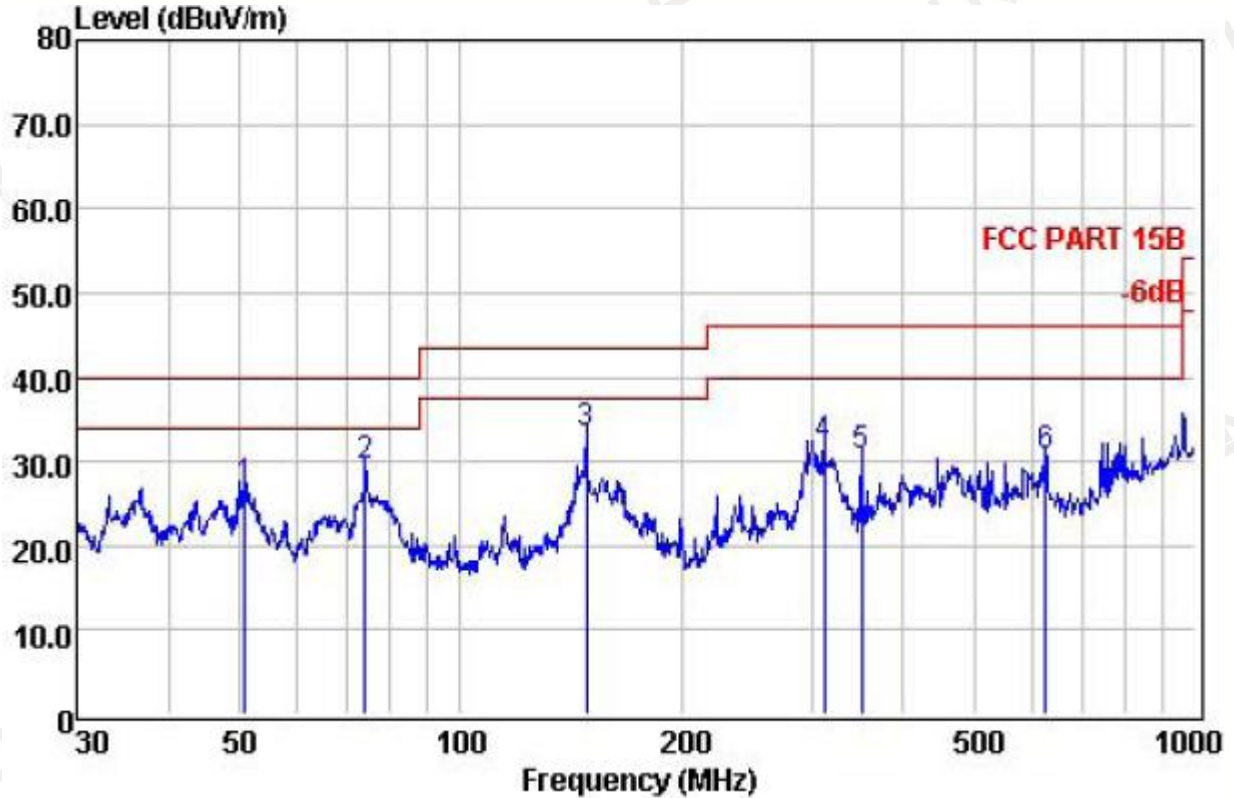

	Read	Antenna	Cable	Limit	Over		
Freq	Level	Factor	Loss	Level	Line	Limit	Remark
MHz	dBuV	dB/m	dB	dBuV/m	dBuV/m	dB	
1	50.76	13.74	12.92	0.12	26.78	40.00	-13.22 QP
2	74.14	17.69	11.51	0.14	29.34	40.00	-10.66 QP
3	148.44	17.58	15.42	0.23	33.23	43.50	-10.27 QP
4	312.18	18.02	13.09	0.68	31.79	46.00	-14.21 QP
5	351.71	16.19	13.67	0.78	30.64	46.00	-15.36 QP
6	625.08	12.02	17.38	1.15	30.55	46.00	-15.45 QP

Remark: Absolute Level = Reading Level + Factor, Margin = Absolute Level – Limit
 Factor = Ant. Factor + Cable Loss – Pre-amplifier

Remark:

- (1) Measuring frequencies from 9 KHz to the 1 GHz, Radiated emission test from 9KHz to 30MHz was verified, and no any emission was found except system noise floor.
- (2) * denotes emission frequency which appearing within the Restricted Bands specified in provision of 15.205, then the general radiated emission limits in 15.209 apply.
- (3) The IF bandwidth of EMI Test Receiver between 30MHz to 1GHz was 120KHz, 1 MHz for measuring above 1 GHz, below 30MHz was 10KHz.

Above 1 GHz Test Results:

Record the worst test data for Antenna B in report.

CH Low of 802.11b Mode (2412MHz)

Horizontal:

Frequency	Reading Result	Factor	Emission Level	Limits	Margin	Detector
(MHz)	(dBμV)	(dB)	(dBμV/m)	(dBμV/m)	(dB)	Type
4824	60.35	-3.64	56.71	74.00	-17.29	PK
4824	51.54	-3.64	47.90	54.00	-6.10	AV
7236	57.58	-0.95	56.63	74.00	-17.37	PK
7236	46.09	-0.95	45.14	54.00	-8.86	AV

Remark: Factor = Antenna Factor + Cable Loss – Pre-amplifier. Margin = Absolute Level – Limit

Vertical:

Frequency	Reading Result	Factor	Emission Level	Limits	Margin	Detector
(MHz)	(dBμV)	(dB)	(dBμV/m)	(dBμV/m)	(dB)	Type
4824	60.85	-3.64	57.21	74.00	-16.79	PK
4824	49.47	-3.64	45.83	54.00	-8.17	AV
7236	58.06	-0.95	57.11	74.00	-16.89	PK
7236	48.28	-0.95	47.33	54.00	-6.67	AV

Remark: Factor = Antenna Factor + Cable Loss – Pre-amplifier. Margin = Absolute Level – Limit

CH Middle of 802.11b Mode (2437MHz)

Horizontal:

Frequency (MHz)	Reading Result (dBμV)	Factor (dB)	Emission Level (dBμV/m)	Limits (dBμV/m)	Margin (dB)	Detector Type
4874	61.99	-3.51	58.48	74.00	-15.52	PK
4874	51.33	-3.51	47.82	54.00	-6.18	AV
7311	57.41	-0.82	56.59	74.00	-17.41	PK
7311	46.81	-0.82	45.99	54.00	-8.01	AV

Remark: Factor = Antenna Factor + Cable Loss – Pre-amplifier. Margin = Absolute Level – Limit

Vertical:

Frequency (MHz)	Reading Result (dBμV)	Factor (dB)	Emission Level (dBμV/m)	Limits (dBμV/m)	Margin (dB)	Detector Type
4874	61.62	-3.51	58.11	74.00	-15.89	PK
4874	51.17	-3.51	47.66	54.00	-6.34	AV
7311	57.38	-0.82	56.56	74.00	-17.44	PK
7311	46.15	-0.82	45.33	54.00	-8.67	AV

Remark: Factor = Antenna Factor + Cable Loss – Pre-amplifier. Margin = Absolute Level – Limit

CH High of 802.11b Mode (2462MHz)

Horizontal:

Frequency	Reading Result	Factor	Emission Level	Limits	Margin	Detector
(MHz)	(dBμV)	(dB)	(dBμV/m)	(dBμV/m)	(dB)	Type
4924	62.28	-3.43	58.85	74.00	-15.15	PK
4924	52.39	-3.43	48.96	54.00	-5.04	AV
7386	56.99	-0.75	56.24	74.00	-17.76	PK
7386	46.41	-0.75	45.66	54.00	-8.34	AV

Remark: Factor = Antenna Factor + Cable Loss – Pre-amplifier. Margin = Absolute Level – Limit

Vertical:

Frequency	Reading Result	Factor	Emission Level	Limits	Margin	Detector
(MHz)	(dBμV)	(dB)	(dBμV/m)	(dBμV/m)	(dB)	Type
4924	62.17	-3.43	58.74	74.00	-15.26	PK
4924	49.05	-3.43	45.62	54.00	-8.38	AV
7386	57.59	-0.75	56.84	74.00	-17.16	PK
7386	46.31	-0.75	45.56	54.00	-8.44	AV

Remark: Factor = Antenna Factor + Cable Loss – Pre-amplifier. Margin = Absolute Level – Limit

Remark :

- (1) Measuring frequencies from 1 GHz to the 25 GHz.
- (2) "F" denotes fundamental frequency; "H" denotes spurious frequency. "E" denotes band edge frequency.
- (3) * denotes emission frequency which appearing within the Restricted Bands specified in provision of 15.205, then the general radiated emission limits in 15.209 apply.
- (4) Data of measurement within this frequency range shown "---" in the table above means the reading of emissions are attenuated more than 20dB below the permissible limits or the field strength is too small to be measured.
- (5) The IF bandwidth of EMI Test Receiver between 30MHz to 1GHz was 120KHz, 1 MHz for measuring above 1 GHz, below 30MHz was 10KHz. The resolution bandwidth of test receiver/spectrum analyzer is 1MHz and video bandwidth is 3MHz for peak measurement with peak detector at frequency above 1GHz. The resolution bandwidth of test receiver/spectrum analyzer is 1MHz and video bandwidth is 10Hz for Average measurement with peak detection at frequency above 1GHz.
- (6) When the test results of Peak Detected below the limits of Average Detected, the Average Detected is not need completed. For example: Top Channel at Fundamental 73.16dBuV/m(PK Value) <93.98(AV Limit), at harmonic 53.20 dBuV/m(PK Value) <54 dBuV/m(AV Limit), the Average Detected not need to completed.

Record the worst test data for Antenna B in report.

CH Low of 802.11g Mode (2412MHz)

Horizontal:

Frequency (MHz)	Reading Result (dBμV)	Factor (dB)	Emission Level (dBμV/m)	Limits (dBμV/m)	Margin (dB)	Detector Type
4824	61.25	-3.64	57.61	74.00	-16.39	PK
4824	49.84	-3.64	46.20	54.00	-7.80	AV
7236	57.39	-0.95	56.44	74.00	-17.56	PK
7236	48.56	-0.95	47.61	54.00	-6.39	AV

Remark: Factor = Antenna Factor + Cable Loss – Pre-amplifier. Margin = Absolute Level – Limit

Vertical:

Frequency (MHz)	Reading Result (dBμV)	Factor (dB)	Emission Level (dBμV/m)	Limits (dBμV/m)	Margin (dB)	Detector Type
4824	61.61	-3.64	57.97	74.00	-16.03	PK
4824	49.23	-3.64	45.59	54.00	-8.41	AV
7236	57.65	-0.95	56.70	74.00	-17.30	PK
7236	46.99	-0.95	46.04	54.00	-7.96	AV

Remark: Factor = Antenna Factor + Cable Loss – Pre-amplifier. Margin = Absolute Level – Limit

CH Middle of 802.11g Mode (2437MHz)

Horizontal:

Frequency (MHz)	Reading Result (dBμV)	Factor (dB)	Emission Level (dBμV/m)	Limits (dBμV/m)	Margin (dB)	Detector Type
4874	62.02	-3.51	58.51	74.00	-15.49	PK
4874	50.36	-3.51	46.85	54.00	-7.15	AV
7311	57.91	-0.82	57.09	74.00	-16.91	PK
7311	47.38	-0.82	46.56	54.00	-7.44	AV

Remark: Factor = Antenna Factor + Cable Loss – Pre-amplifier. Margin = Absolute Level – Limit

Vertical:

Frequency (MHz)	Reading Result (dBμV)	Factor (dB)	Emission Level (dBμV/m)	Limits (dBμV/m)	Margin (dB)	Detector Type
4874	62.00	-3.51	58.49	74.00	-15.51	PK
4874	50.29	-3.51	46.78	54.00	-7.22	AV
7311	57.34	-0.82	56.52	74.00	-17.48	PK
7311	47.21	-0.82	46.39	54.00	-7.61	AV

Remark: Factor = Antenna Factor + Cable Loss – Pre-amplifier. Margin = Absolute Level – Limit

CH High of 802.11g Mode (2462MHz)

Horizontal:

Frequency	Reading Result	Factor	Emission Level	Limits	Margin	Detector
(MHz)	(dBμV)	(dB)	(dBμV/m)	(dBμV/m)	(dB)	Type
4924	61.09	-3.43	57.66	74.00	-16.34	PK
4924	50.11	-3.43	46.68	54.00	-7.32	AV
7386	58.37	-0.75	57.62	74.00	-16.38	PK
7386	47.46	-0.75	46.71	54.00	-7.29	AV

Remark: Factor = Antenna Factor + Cable Loss – Pre-amplifier. Margin = Absolute Level – Limit

Vertical:

Frequency	Reading Result	Factor	Emission Level	Limits	Margin	Detector
(MHz)	(dBμV)	(dB)	(dBμV/m)	(dBμV/m)	(dB)	Type
4924	62.77	-3.43	59.34	74.00	-14.66	PK
4924	50.35	-3.43	46.92	54.00	-7.08	AV
7386	58.17	-0.75	57.42	74.00	-16.58	PK
7386	47.30	-0.75	46.55	54.00	-7.45	AV

Remark: Factor = Antenna Factor + Cable Loss – Pre-amplifier. Margin = Absolute Level – Limit

Remark :

- (1) Measuring frequencies from 1 GHz to the 25 GHz.
- (2) "F" denotes fundamental frequency; "H" denotes spurious frequency. "E" denotes band edge frequency.
- (3) * denotes emission frequency which appearing within the Restricted Bands specified in provision of 15.205, then the general radiated emission limits in 15.209 apply.
- (4) Data of measurement within this frequency range shown "---" in the table above means the reading of emissions are attenuated more than 20dB below the permissible limits or the field strength is too small to be measured.
- (5) The IF bandwidth of EMI Test Receiver between 30MHz to 1GHz was 120KHz, 1 MHz for measuring above 1 GHz, below 30MHz was 10KHz. The resolution bandwidth of test receiver/spectrum analyzer is 1MHz and video bandwidth is 3MHz for peak measurement with peak detector at frequency above 1GHz. The resolution bandwidth of test receiver/spectrum analyzer is 1MHz and video bandwidth is 10Hz for Average measurement with peak detection at frequency above 1GHz.
- (6) When the test results of Peak Detected below the limits of Average Detected, the Average Detected is not need completed. For example: Top Channel at Fundamental 73.16dBuV/m(PK Value) <93.98(AV Limit), at harmonic 53.20 dBuV/m(PK Value) <54 dBuV/m(AV Limit), the Average Detected not need to completed.

Record the worst test data for Combination of Antenna A and Antenna B in the report.

CH Low of 802.11n/H20 Mode (2412MHz)

Horizontal:

Frequency (MHz)	Reading Result (dB μ V)	Factor (dB)	Emission Level (dB μ V/m)	Limits (dB μ V/m)	Margin (dB)	Detector Type
4824	63.05	-3.64	59.41	74.00	-14.59	PK
4824	52.04	-3.64	48.40	54.00	-5.60	AV
7236	59.05	-0.95	58.10	74.00	-15.90	PK
7236	49.06	-0.95	48.11	54.00	-5.89	AV

Remark: Factor = Antenna Factor + Cable Loss – Pre-amplifier. Margin = Absolute Level – Limit

Vertical:

Frequency (MHz)	Reading Result (dB μ V)	Factor (dB)	Emission Level (dB μ V/m)	Limits (dB μ V/m)	Margin (dB)	Detector Type
4824	63.31	-3.64	59.67	74.00	-14.33	PK
4824	52.15	-3.64	48.51	54.00	-5.49	AV
7236	58.36	-0.95	57.41	74.00	-16.59	PK
7236	49.28	-0.95	48.33	54.00	-5.67	AV

Remark: Factor = Antenna Factor + Cable Loss – Pre-amplifier. Margin = Absolute Level – Limit

CH Middle of 802.11n/H20 Mode (2437MHz)

Horizontal:

Frequency (MHz)	Reading Result (dBμV)	Factor (dB)	Emission Level (dBμV/m)	Limits (dBμV/m)	Margin (dB)	Detector Type
4874	63.27	-3.51	59.76	74.00	-14.24	PK
4874	52.39	-3.51	48.88	54.00	-5.12	AV
7311	59.07	-0.82	58.25	74.00	-15.75	PK
7311	49.18	-0.82	48.36	54.00	-5.64	AV

Remark: Factor = Antenna Factor + Cable Loss – Pre-amplifier. Margin = Absolute Level – Limit

Vertical:

Frequency (MHz)	Reading Result (dBμV)	Factor (dB)	Emission Level (dBμV/m)	Limits (dBμV/m)	Margin (dB)	Detector Type
4874	63.26	-3.51	59.75	74.00	-14.25	PK
4874	51.98	-3.51	48.47	54.00	-5.53	AV
7311	59.42	-0.82	58.60	74.00	-15.40	PK
7311	49.36	-0.82	48.54	54.00	-5.46	AV

Remark: Factor = Antenna Factor + Cable Loss – Pre-amplifier. Margin = Absolute Level – Limit

CH High of 802.11n/H20 Mode (2462MHz)

Horizontal:

Frequency (MHz)	Reading Result (dBμV)	Factor (dB)	Emission Level (dBμV/m)	Limits (dBμV/m)	Margin (dB)	Detector Type
4924	62.58	-3.43	59.15	74.00	-14.85	PK
4924	51.99	-3.43	48.56	54.00	-5.44	AV
7386	58.06	-0.75	57.31	74.00	-16.69	PK
7386	48.93	-0.75	48.18	54.00	-5.82	AV

Remark: Factor = Antenna Factor + Cable Loss – Pre-amplifier. Margin = Absolute Level – Limit

Vertical:

Frequency (MHz)	Reading Result (dBμV)	Factor (dB)	Emission Level (dBμV/m)	Limits (dBμV/m)	Margin (dB)	Detector Type
4924	63.01	-3.43	59.58	74.00	-14.42	PK
4924	52.17	-3.43	48.74	54.00	-5.26	AV
7386	58.64	-0.75	57.89	74.00	-16.11	PK
7386	48.91	-0.75	48.16	54.00	-5.84	AV

Remark: Factor = Antenna Factor + Cable Loss – Pre-amplifier. Margin = Absolute Level – Limit

Remark :

- (1) Measuring frequencies from 1 GHz to the 25 GHz.
- (2) "F" denotes fundamental frequency; "H" denotes spurious frequency. "E" denotes band edge frequency.
- (3) * denotes emission frequency which appearing within the Restricted Bands specified in provision of 15.205, then the general radiated emission limits in 15.209 apply.
- (4) Data of measurement within this frequency range shown "---" in the table above means the reading of emissions are attenuated more than 20dB below the permissible limits or the field strength is too small to be measured.
- (5) The IF bandwidth of EMI Test Receiver between 30MHz to 1GHz was 120KHz, 1 MHz for measuring above 1 GHz, below 30MHz was 10KHz. The resolution bandwidth of test receiver/spectrum analyzer is 1MHz and video bandwidth is 3MHz for peak measurement with peak detector at frequency above 1GHz. The resolution bandwidth of test receiver/spectrum analyzer is 1MHz and video bandwidth is 10Hz for Average measurement with peak detection at frequency above 1GHz.
- (6) When the test results of Peak Detected below the limits of Average Detected, the Average Detected is not need completed. For example: Top Channel at Fundamental 73.16dBuV/m(PK Value) <93.98(AV Limit), at harmonic 53.20 dBuV/m(PK Value) <54 dBuV/m(AV Limit), the Average Detected not need to completed.

Record the worst test data for Combination of Antenna A and Antenna B in the report.

CH Low of 802.11n/H40 Mode (2422MHz)

Horizontal:

Frequency (MHz)	Reading Result (dBμV)	Factor (dB)	Emission Level (dBμV/m)	Limits (dBμV/m)	Margin (dB)	Detector Type
4884	60.61	-3.64	56.97	74.00	-17.03	PK
4884	50.02	-3.64	46.38	54.00	-7.62	AV
7266	56.98	-0.95	56.03	74.00	-17.97	PK
7266	49.21	-0.95	48.26	54.00	-5.74	AV

Remark: Factor = Antenna Factor + Cable Loss – Pre-amplifier. Margin = Absolute Level – Limit

Vertical:

Frequency (MHz)	Reading Result (dBμV)	Factor (dB)	Emission Level (dBμV/m)	Limits (dBμV/m)	Margin (dB)	Detector Type
4884	60.55	-3.64	56.91	74.00	-17.09	PK
4884	51.34	-3.64	47.70	54.00	-6.30	AV
7266	57.08	-0.95	56.13	74.00	-17.87	PK
7266	46.54	-0.95	45.59	54.00	-8.41	AV

Remark: Factor = Antenna Factor + Cable Loss – Pre-amplifier. Margin = Absolute Level – Limit

CH Middle of 802.11n/H40 Mode (2437MHz)

Horizontal:

Frequency (MHz)	Reading Result (dBμV)	Factor (dB)	Emission Level (dBμV/m)	Limits (dBμV/m)	Margin (dB)	Detector Type
4874	60.89	-3.51	57.38	74.00	-16.62	PK
4874	49.32	-3.51	45.81	54.00	-8.19	AV
7311	57.23	-0.82	56.41	74.00	-17.59	PK
7311	47.97	-0.82	47.15	54.00	-6.85	AV

Remark: Factor = Antenna Factor + Cable Loss – Pre-amplifier. Margin = Absolute Level – Limit

Vertical:

Frequency (MHz)	Reading Result (dBμV)	Factor (dB)	Emission Level (dBμV/m)	Limits (dBμV/m)	Margin (dB)	Detector Type
4874	60.34	-3.51	56.83	74.00	-17.17	PK
4874	50.21	-3.51	46.70	54.00	-7.30	AV
7311	58.62	-0.82	57.80	74.00	-16.20	PK
7311	47.55	-0.82	46.73	54.00	-7.27	AV

Remark: Factor = Antenna Factor + Cable Loss – Pre-amplifier. Margin = Absolute Level – Limit

CH High of 802.11n/H40 Mode (2452MHz)

Horizontal:

Frequency (MHz)	Reading Result (dBμV)	Factor (dB)	Emission Level (dBμV/m)	Limits (dBμV/m)	Margin (dB)	Detector Type
4904	61.33	-3.43	57.90	74.00	-16.10	PK
4904	52.34	-3.43	48.91	54.00	-5.09	AV
7356	57.68	-0.75	56.93	74.00	-17.07	PK
7356	47.77	-0.75	47.02	54.00	-6.98	AV

Remark: Factor = Antenna Factor + Cable Loss – Pre-amplifier. Margin = Absolute Level – Limit

Vertical:

Frequency (MHz)	Reading Result (dBμV)	Factor (dB)	Emission Level (dBμV/m)	Limits (dBμV/m)	Margin (dB)	Detector Type
4904	61.41	-3.43	57.98	74.00	-16.02	PK
4904	51.99	-3.43	48.56	54.00	-5.44	AV
7356	57.69	-0.75	56.94	74.00	-17.06	PK
7386	47.23	-0.75	46.48	54.00	-7.52	AV

Remark: Factor = Antenna Factor + Cable Loss – Pre-amplifier. Margin = Absolute Level – Limit

Remark :

- (1) Measuring frequencies from 1 GHz to the 25 GHz.
- (2) "F" denotes fundamental frequency; "H" denotes spurious frequency. "E" denotes band edge frequency.
- (3) * denotes emission frequency which appearing within the Restricted Bands specified in provision of 15.205, then the general radiated emission limits in 15.209 apply.
- (4) Data of measurement within this frequency range shown "---" in the table above means the reading of emissions are attenuated more than 20dB below the permissible limits or the field strength is too small to be measured.
- (5) The IF bandwidth of EMI Test Receiver between 30MHz to 1GHz was 120KHz, 1 MHz for measuring above 1 GHz, below 30MHz was 10KHz. The resolution bandwidth of test receiver/spectrum analyzer is 1MHz and video bandwidth is 3MHz for peak measurement with peak detector at frequency above 1GHz. The resolution bandwidth of test receiver/spectrum analyzer is 1MHz and video bandwidth is 10Hz for Average measurement with peak detection at frequency above 1GHz.
- (6) When the test results of Peak Detected below the limits of Average Detected, the Average Detected is not need completed. For example: Top Channel at Fundamental 73.16dBuV/m(PK Value) <93.98(AV Limit), at harmonic 53.20 dBuV/m(PK Value) <54 dBuV/m(AV Limit), the Average Detected not need to completed.

5. BAND EDGE

5.1 Limits

FCC PART 15.247 Emissions radiated outside of the specified frequency bands, except for harmonics, shall be attenuated by at least 20 dB below the level of the fundamental or to the general radiated emission limits in §15.209, whichever is the lesser attenuation.

5.2 Test Procedure

The band edge compliance of RF radiated emission should be measured by following the guidance in ANSI C63.10 with respect to maximizing the emission by rotating the EUT, measuring the emission while the EUT is situated in three orthogonal planes (if appropriate), adjusting the measurement antenna height and polarization etc. Set RBW to 100KHz and VBM to 300KHz to measure the peak field strength and set RBW to 1MHz and VBW to 10Hz to measure the average radiated field strength. The conducted RF band edge was measured by using a spectrum analyzer. Set span wide enough to capture the highest in-band emission and the emission at the band edge. Set RBW to 100 KHz and VBW to 300 KHz, to measure the conducted peak band edge.

5.3 Test Result

PASS

We tested at 802.11b/802.11g mode at the antenna single;

We tested at 802.11n HT20/802.11n HT40 mode at the antenna single and antenna combination; and recored the worst data at 802.11n 40 Combined Antenna A and Antenna B.

Horizontal:

Frequency (MHz)	Reading Result (dBµV)	Factor (dB)	Emission Level (dBµV/m)	Limits (dBµV/m)	Margin (dB)	Detector Type
2310	53.17	-5.81	47.36	74.00	-26.64	PK
2310	/	-5.81	/	54.00	/	AV
2390	61.33	-5.84	55.49	74.00	-18.51	PK
2390	48.27	-5.84	42.43	54.00	-11.57	AV
2400	65.54	-5.84	59.70	74.00	-14.30	PK
2400	48.39	-5.84	42.55	54.00	-11.45	AV

Remark: Factor = Antenna Factor + Cable Loss – Pre-amplifier.

Vertical:

Frequency (MHz)	Reading Result (dBµV)	Factor (dB)	Emission Level (dBµV/m)	Limits (dBµV/m)	Margin (dB)	Detector Type
2310	53.57	-5.81	47.76	74.00	-26.24	PK
2310	/	-5.81	/	54.00	/	AV
2390	62.74	-5.84	56.90	74.00	-17.10	PK
2390	51.58	-5.84	45.74	54.00	-8.26	AV
2400	63.39	-5.84	57.55	74.00	-16.45	PK
2400	50.31	-5.84	44.47	54.00	-9.53	AV

Remark: Factor = Antenna Factor + Cable Loss – Pre-amplifier.

Horizontal :

Frequency (MHz)	Reading Result (dBμV)	Factor (dB)	Emission Level (dBμV/m)	Limits (dBμV/m)	Margin (dB)	Detector Type
2483.5	53.02	-5.54	47.48	74.00	-26.52	PK
2483.5	/	-5.54	/	54.00	/	AV
2500	53.26	-5.54	47.72	74.00	-26.28	PK
2500	/	-5.72	/	54.00	/	AV

Remark: Factor = Antenna Factor + Cable Loss – Pre-amplifier.

Vertical:

Frequency (MHz)	Reading Result (dBμV)	Factor (dB)	Emission Level (dBμV/m)	Limits (dBμV/m)	Margin (dB)	Detector Type
2483.5	55.36	-5.54	49.82	74	-24.18	PK
2483.5	/	-5.54	/	54	/	AV
2500	54.92	-5.72	49.2	74	-24.8	PK
2500	/	-5.72	/	54	/	AV

Remark: Factor = Antenna Factor + Cable Loss – Pre-amplifier.

6. OCCUPIED BANDWIDTH MEASUREMENT

6.1 Test Limit

FCC Part15(15.247), Subpart C				
Section	Test Item	Limit	Frequency Range (MHz)	Result
15.247(a)(2)	Bandwidth	$\geq 500\text{KHz}$ (6dB bandwidth)	2400-2483.5	PASS

6.2 Test Procedure

1. The EUT was placed on a turn table which is 0.8m above ground plane.
2. Set EUT as normal operation.
3. Based on FCC Part15 C Section 15.247: RBW=100KHz, VBW=300KHz.
4. The useful radiated emission from the EUT was detected by the spectrum analyzer with peak detector.

6.3 Measurement Equipment Used

Same as Radiated Emission Measurement

6.4 Test Result

PASS

ANT A

Type	Channel	6dB Bandwidth (MHz)	Limit (KHz)	Result
802.11b	01	8.33	≥ 500	Pass
	06	8.36		
	11	8.34		
802.11g	01	15.71	≥ 500	Pass
	06	15.68		
	11	15.11		
802.11nHT20	01	15.97	≥ 500	Pass
	06	15.65		
	11	15.65		
802.11nHT40	03	34.41	≥ 500	Pass
	06	34.17		
	09	35.64		

ANT B

Type	Channel	6dB Bandwidth (MHz)	Limit (KHz)	Result
802.11b	01	8.33	≥ 500	Pass
	06	8.32		
	11	8.32		
802.11g	01	15.10	≥ 500	Pass
	06	15.11		
	11	15.11		
802.11nHT20	01	16.60	≥ 500	Pass
	06	15.10		
	11	15.99		
802.11nHT40	03	35.09	≥ 500	Pass
	06	35.09		
	09	35.09		

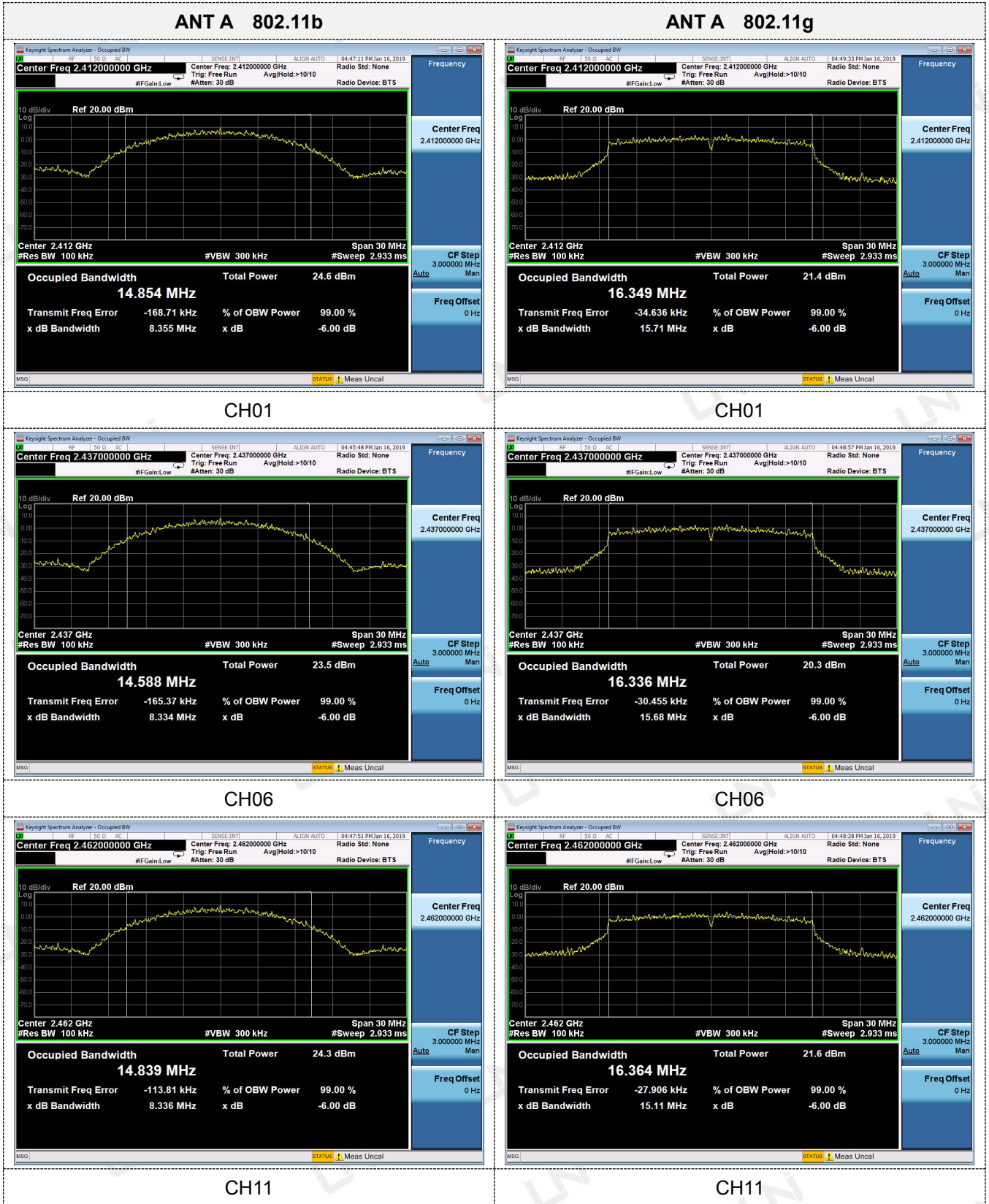

ANT A 802.11n HT20

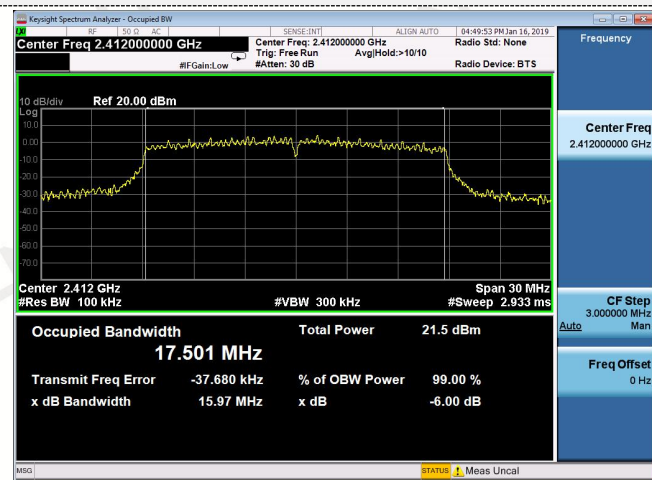

ANT A 802.11n HT40

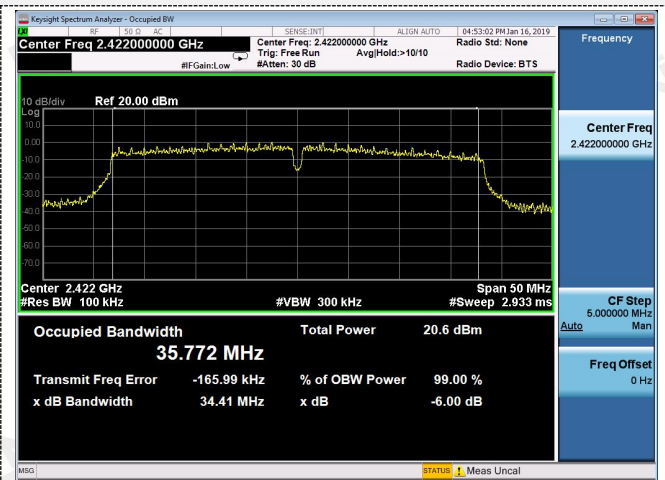

CH01

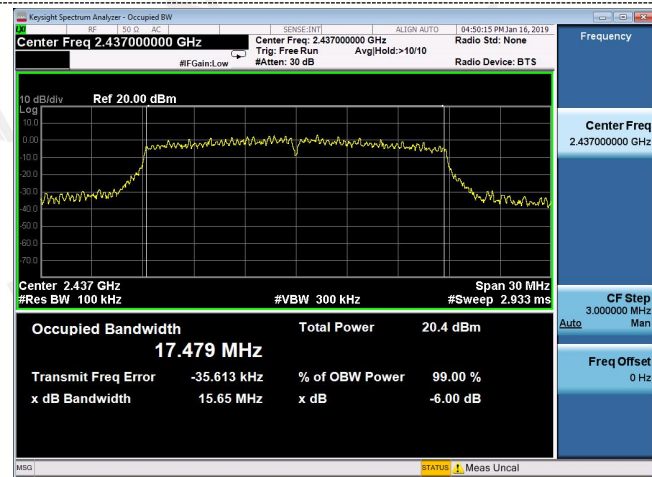

CH03

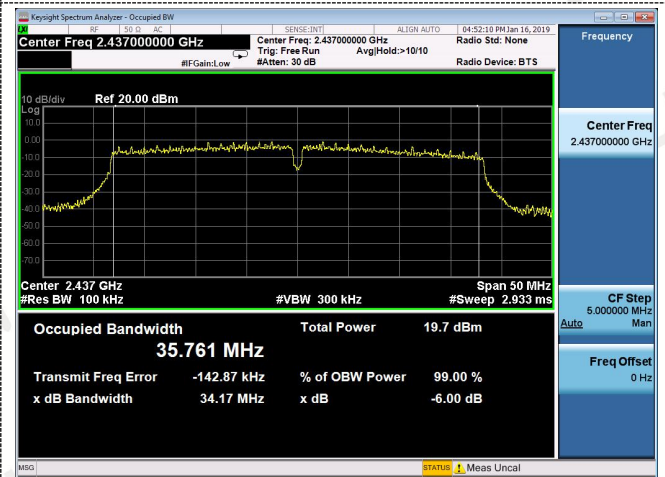

CH06

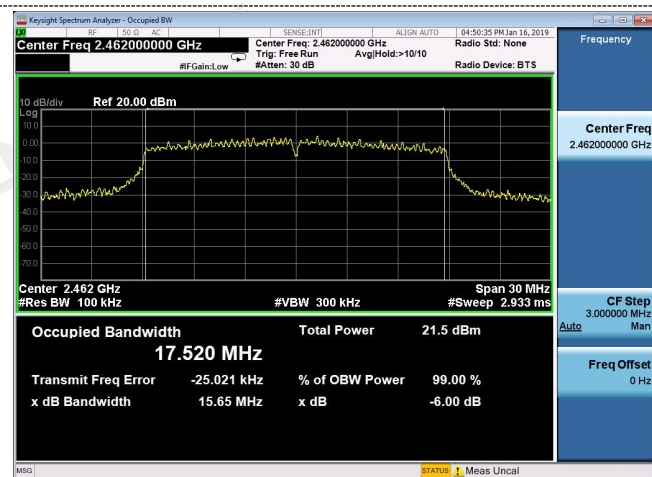

CH06

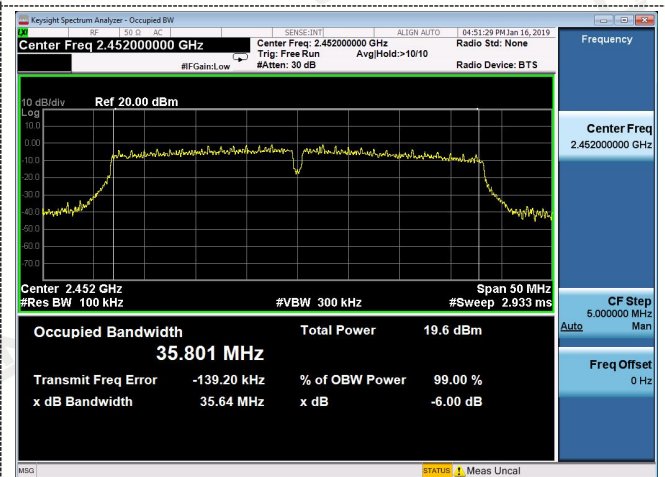

CH11

CH09

ANT B 802.11b

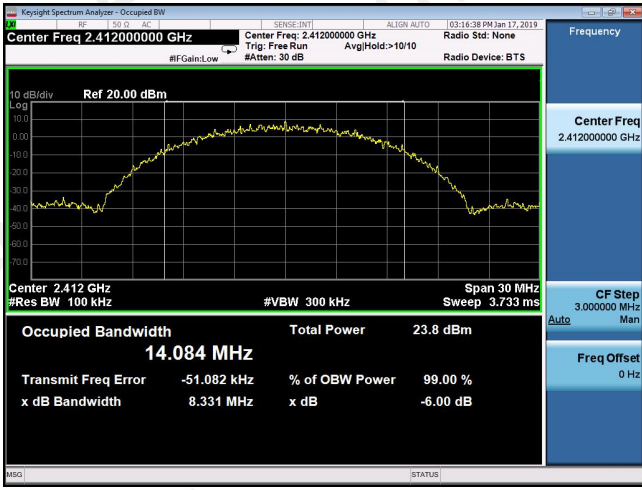

ANT B 802.11g

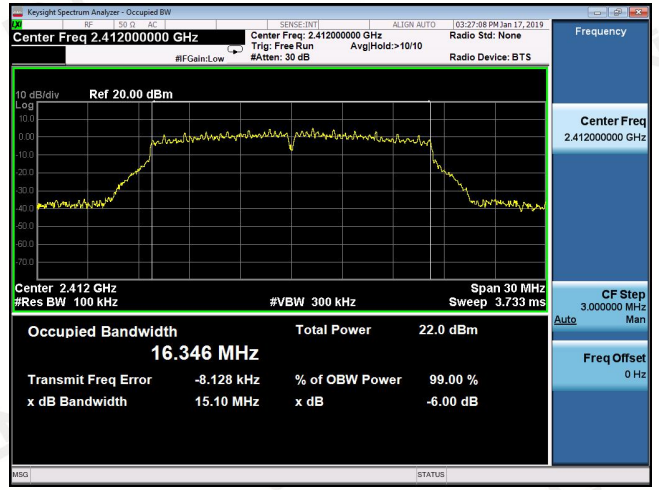

CH01

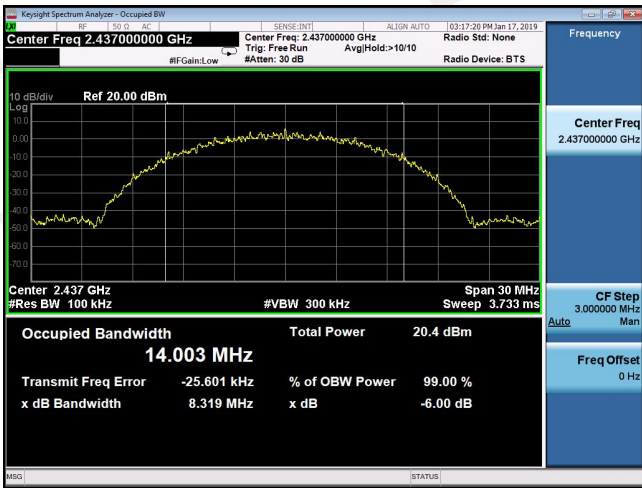

CH01

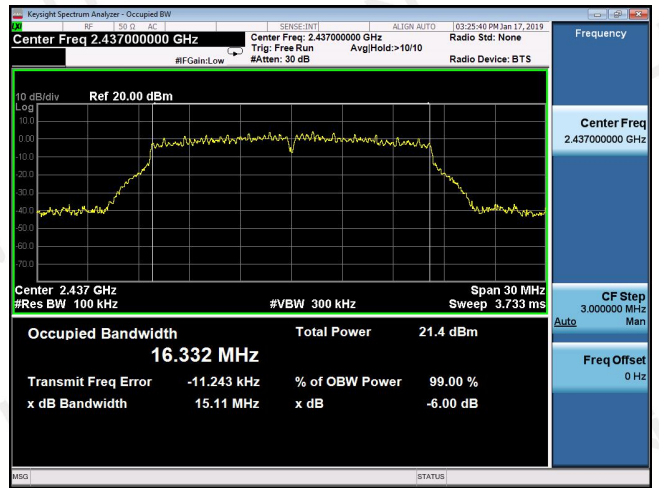

CH06



CH06

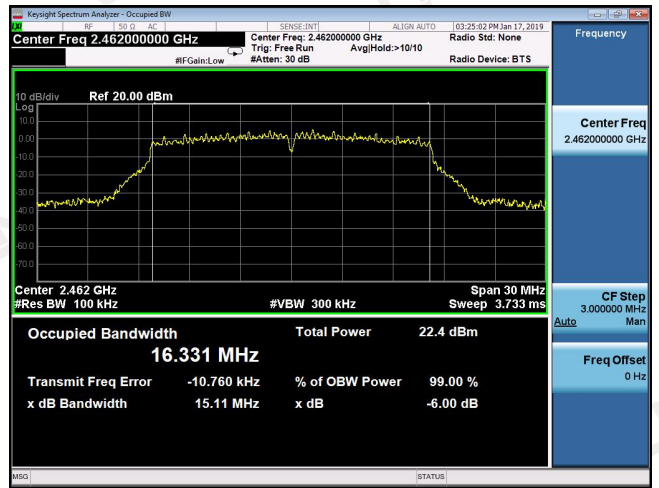

CH11

CH11

ANT B 802.11n HT20

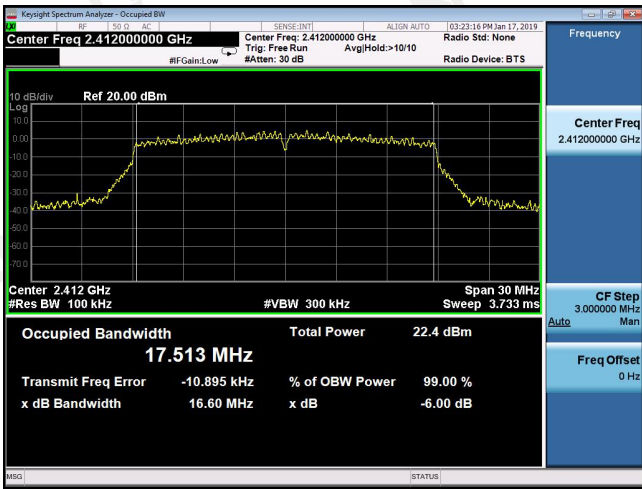

ANT B 802.11n HT40

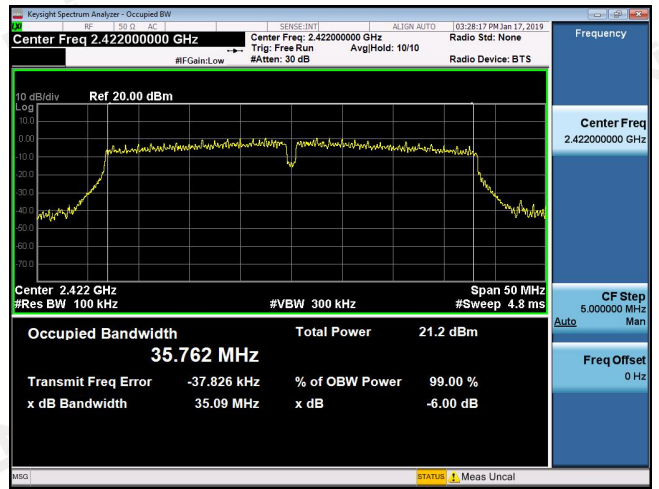

CH01

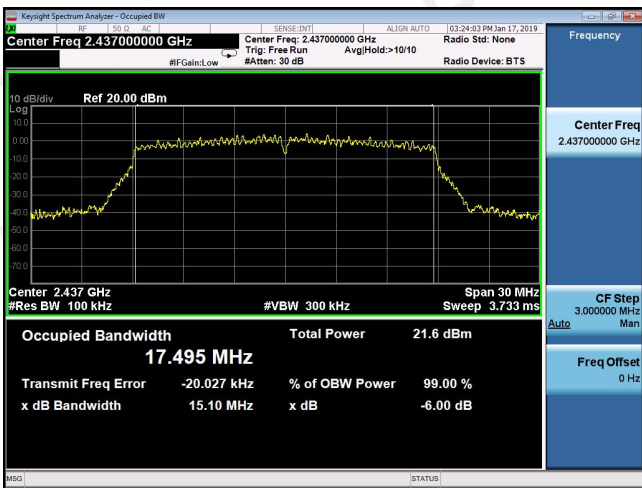

CH03

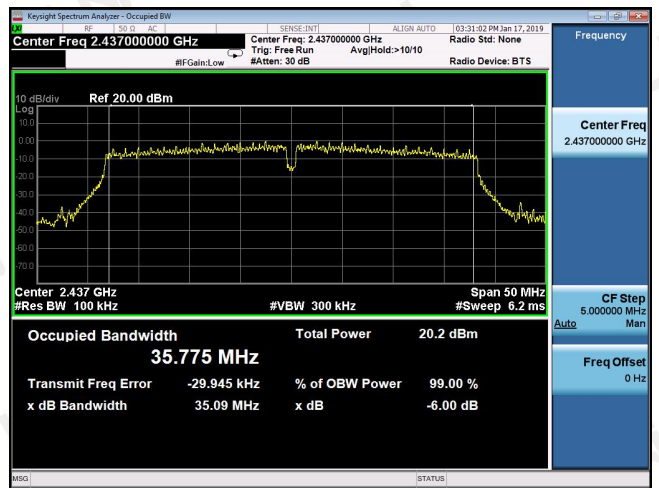

CH06

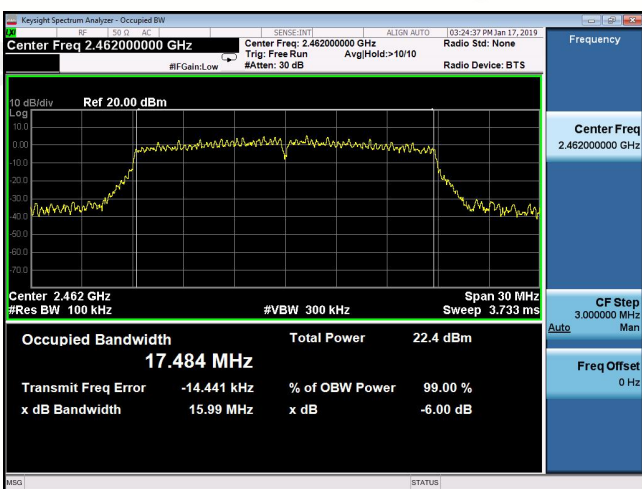

CH06

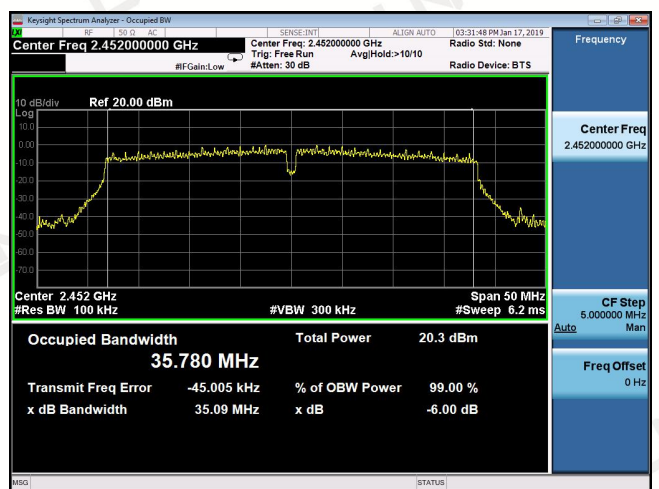

CH11

CH09

7. POWER SPECTRAL DENSITY TEST

7.1 Test Limit

FCC Part15(15.247), Subpart C				
Section	Test Item	Limit	Frequency Range (MHz)	Result
15.247	Power Spectral Density	8 dBm (in any 3KHz)	2400-2483.5	PASS

7.2 Test Procedure

1. The EUT was placed on a turn table which is 0.8m above ground plane.
2. Set EUT as normal operation.
3. Based on FCC Part15 C Section 15.247: RBW=3KHz, VBW=10KHz.
4. The useful radiated emission from the EUT was detected by the spectrum analyzer with peak detector.

7.3 Measurement Equipment Used

Same as Radiated Emission Measurement

7.4 Test Result

PASS

Type	Channel	Power Spectral Density (dBm/3KHz)	Power Spectral Density (dBm/3KHz)	Power Spectral Density Total(dBm/3KHz)	Limit (dBm/3KHz)	Result
		ANT A	ANT B			
802.11b	01	-5.569	-6.266	/	8.00	Pass
	06	-6.492	-5.914	/		
	11	-5.577	-5.398	/		
802.11g	01	-10.904	-10.408	/	8.00	Pass
	06	-12.289	-10.858	/		
	11	-11.385	-10.798	/		
802.11n(HT20)	01	-10.527	-9.224	-6.82	8.00	Pass
	06	-11.805	-10.512	-8.10		
	11	-10.319	-10.049	-7.17		
802.11n(HT40)	03	-12.813	-13.829	-10.28	8.00	Pass
	06	-13.762	-14.401	-11.06		
	09	-14.389	-14.576	-11.47		

Note:

- 1). Measured peak power spectrum density at difference data rate for each mode and recorded worst case for each mode.
- 2). Test results including cable loss;
- 3). 802.11b ,802.11g mode the ANT A and ANT B can not TX and RX at the same time;
- 4). 802.11n(20)/802.11n(40) mode the ANT A and ANT B can TX and RX at the same time;
- 5). Directional gain=GANT +10log(N)dbi =2.0+10log(2)=5.01dbi;
- 6). For MIMO with CCD technology device, The Directional Gain= Gain of individual transmit antennas (dBi) + Array gain; Array gain = 10 log (Nant), where Nant is the number of transmit antennas.

