



**CFR 47 FCC PART 15 SUBPART E
ISED RSS-247 ISSUE 2**

CERTIFICATION TEST REPORT

For

IEEE 802.11a/b/g/n/ac 2T2R USB Wi-Fi Module Integrated BT 2.1+EDR/4.2/5.1

MODEL NUMBER: SKO.WB663U.3

FCC ID: 2AR82-SKOWB663U301

IC: 24728-SKOWB663U31

REPORT NUMBER: 4790053515-4

ISSUE DATE: August 17, 2021

Prepared for

**Guangzhou Shikun Electronics Co., Ltd
NO.6 Liankun Road,Huangpu District,Guangzhou,China**

Prepared by

UL Verification Services (Guangzhou) Co., Ltd, Song Shan Lake Branch

Building 10, Innovation Technology Park, No. 1, Li Bin Road, Song Shan Lake Hi-Tech Development Zone Dongguan, 523808, People's Republic of China

Tel: +86 769 22038881

Fax: +86 769 33244054

Website: www.ul.com



Revision History

<u>Rev.</u>	<u>Issue Date</u>	<u>Revisions</u>	<u>Revised By</u>
V0	08/17/2021	Initial Issue	



Summary of Test Results			
Clause	Test Items	FCC/IC Rules	Test Results
1	6dB/26dB Bandwidth	FCC 15.407 (a)&(e) RSS-247 Clause 6.2	PASS
2	99% Occupied Bandwidth	RSS-Gen Clause 6.6	PASS
3	Conducted Output Power	FCC 15.407 (a) RSS-247 Clause 6.2	PASS
4	Power Spectral Density	FCC 15.407 (a) RSS-247 Clause 6.2	PASS
5	Radiated Bandedge and Spurious Emission	FCC 15.407 (b) FCC 15.209 FCC 15.205 RSS-247 Clause 6.2 RSS-GEN Clause 8.9	PASS
6	Conducted Emission Test for AC Power Port	FCC 15.207 RSS-GEN Clause 8.8	PASS
7	Frequency Stability	FCC 15.407 (g)	PASS
8	Dynamic Frequency Selection	FCC 15.407 (h) RSS-247 Clause 6.3	PASS
9	Antenna Requirement	FCC 15.203 RSS-GEN Clause 6.8	PASS
Note: 1.This test report is only published to and used by the applicant, and it is not for evidence purpose in China. 2. The measurement result for the sample received is <Pass> according to < CFR 47 FCC PART 15 SUBPART E >< ISED RSS-247 > when <Accuracy Method> decision rule is applied.			



TABLE OF CONTENTS

1. ATTESTATION OF TEST RESULTS	7
2. TEST METHODOLOGY	8
3. FACILITIES AND ACCREDITATION	8
4. CALIBRATION AND UNCERTAINTY	9
4.1. MEASURING INSTRUMENT CALIBRATION	9
4.2. MEASUREMENT UNCERTAINTY.....	9
5. EQUIPMENT UNDER TEST	10
5.1. DESCRIPTION OF EUT	10
5.2. MAXIMUM OUTPUT POWER.....	11
5.3. CHANNEL LIST.....	12
5.4. TEST CHANNEL CONFIGURATION.....	13
5.5. DESCRIPTION OF AVAILABLE ANTENNAS	15
5.6. THE WORSE CASE POWER SETTING PARAMETER.....	15
5.7. THE WORSE CASE CONFIGURATIONS	16
5.8. DESCRIPTION OF TEST SETUP.....	17
6. MEASURING INSTRUMENT AND SOFTWARE USED	18
7. ANTENNA PORT TEST RESULTS	20
7.1. ON TIME AND DUTY CYCLE.....	20
7.2. 6/26 dB EMISSION BANDWIDTH AND 99 % OCCUPIED BANDWIDTH	21
7.3. CONDUCTED OUTPUT POWER.....	23
7.4. POWER SPECTRAL DENSITY.....	26
8. RADIATED TEST RESULTS.....	28
8.1. RESTRICTED BANDEDGE.....	35
8.1.1. 802.11a 20 SISO MODE.....	35
UNII-1 BAND	35
UNII-2A BAND	37
UNII-2C BAND.....	39
UNII-3 BAND	42
8.1.1. 802.11ac VHT20 MIMO MODE.....	44
UNII-1 BAND	44
UNII-2A BAND	46
UNII-2C BAND	48
UNII-3 BAND	51
8.1.2. 802.11ac VHT40 MIMO MODE.....	53
UNII-1 BAND	53
UNII-2A BAND	55



UNII-2C BAND	57
UNII-3 BAND	60
8.1.3. 802.11ac VHT80 MIMO MODE	62
UNII-1 BAND	62
UNII-2A BAND	64
UNII-2C BAND	66
UNII-3 BAND	69
8.2. SPURIOUS EMISSIONS (1 GHz ~ 7 GHz)	70
8.2.1. 802.11a 20 SISO MODE	70
UNII-1 BAND	70
UNII-2A BAND	76
UNII-2C BAND	82
STRADDLE CHANNEL 144	88
UNII-3 BAND	90
8.3. SPURIOUS EMISSIONS (7 GHz ~ 18 GHz)	96
8.3.1. 802.11a SISO MODE	96
UNII-1 BAND	96
UNII-2A BAND	102
UNII-2C BAND	108
STRADDLE CHANNEL 144	114
UNII-3 BAND	116
8.3.2. 802.11ac VHT20 MIMO MODE	122
UNII-1 BAND	122
UNII-2A BAND	128
UNII-2C BAND	134
STRADDLE CHANNEL 144	140
UNII-3 BAND	142
8.3.3. 802.11ac VHT40 MIMO MODE	148
UNII-1 BAND	148
UNII-2A BAND	152
UNII-2C BAND	156
STRADDLE CHANNEL 142	162
UNII-3 BAND	164
8.3.4. 802.11ac VHT80 MIMO MODE	168
UNII-1 BAND	168
UNII-2A BAND	170
UNII-2C BAND	172
STRADDLE CHANNEL 138	176
UNII-3 BAND	178
8.4. SPURIOUS EMISSIONS (18 GHz ~ 26 GHz)	180
8.4.1. 802.11ac VHT80 MODE	180
8.5. SPURIOUS EMISSIONS (26 GHz ~ 40 GHz)	182
8.5.1. 802.11ac VHT80 MODE	182
8.6. SPURIOUS EMISSIONS (30 MHz ~ 1 GHz)	184
8.6.1. 802.11ac VHT80 MODE	184
8.7. SPURIOUS EMISSIONS BELOW 30 MHz	186
8.7.1. 802.11ac VHT80 MODE	186
9. AC POWER LINE CONDUCTED EMISSIONS	189



9.1.1. 802.11ac VHT80 MODE 190

10. FREQUENCY STABILITY..... 192

11. DYNAMIC FREQUENCY SELECTION 194

12. ANTENNA REQUIREMENTS 198

13. Appendix..... 199

13.1. *Appendix A1: Emission Bandwidth* 199

13.1.1. Test Result 199

13.1.2. Test Graphs 202

13.2. *Appendix A2: Occupied channel bandwidth*..... 246

13.2.1. Test Result 246

13.2.2. Test Graphs 249

13.3. *Appendix A3: Min emission bandwidth* 293

13.3.1. Test Result 293

13.3.2. Test Graphs 294

13.4. *Appendix B: Maximum conducted output power* 308

13.4.1. Test Result 308

13.5. *Appendix C: Maximum power spectral density* 312

13.5.1. Test Result 312

13.5.2. Test Graphs 315

13.6. *Appendix D: Duty Cycle*..... 341

13.6.1. Test Result 341

13.6.2. Test Graphs 342

13.7. *Appendix E: Frequency Stability* 344

13.7.1. Test Result 344

13.8. *Appendix F: DYNAMIC FREQUENCY SELECTION* 346

13.8.1. Test Result 346



1. ATTESTATION OF TEST RESULTS

Applicant Information

Company Name: Guangzhou Shikun Electronics Co., Ltd
Address: NO.6 Liankun Road,Huangpu District,Guangzhou,China

Manufacturer Information

Company Name: Guangzhou Shikun Electronics Co., Ltd
Address: NO.6 Liankun Road,Huangpu District,Guangzhou,China

EUT Information

EUT Name: IEEE 802.11a/b/g/n/ac 2T2R USB Wi-Fi Module Integrated BT
2.1+EDR/4.2/5.1
Model: SKO.WB663U.3
Sample Received Date: August 04, 2021
Sample Status: Normal
Sample ID: 4123864
Date of Tested: August 06, 2021 ~ August 16, 2021

APPLICABLE STANDARDS	
STANDARD	TEST RESULTS
CFR 47 FCC PART 15 SUBPART E	PASS
ISED RSS-247 Issue 2	PASS
ISED RSS-GEN Issue 5	PASS

Prepared By:

Mick Zhang
Project Engineer

Checked By:

Shawn Wen
Laboratory Leader

Approved By:

Stephen Guo
Laboratory Manager



2. TEST METHODOLOGY

The tests documented in this report were performed in accordance with ANSI C63.10-2013, CFR 47 FCC Part 2, CFR 47 FCC Part 15, KDB 789033 D02 v02r01, RSS-GEN Issue 5, RSS-247 Issue 2, KDB414788 D01 Radiated Test Site v01, KDB 662911 D01 Multiple Transmitter Output v02r01, KDB 905462 D02 UNII DFS Compliance Procedures New Rules v02, KDB 905462 D03 UNII clients without radar detection New Rules v01r02, KDB 905462 D04 Operational Modes for DFS Testing New Rules v01 and KDB 905462 D06 802 11 Channel Plans New Rules v02.

3. FACILITIES AND ACCREDITATION

Accreditation Certificate	<p>A2LA (Certificate No.: 4102.01) UL Verification Services (Guangzhou) Co., Ltd. Song Shan Lake Branch. has been assessed and proved to be in compliance with A2LA.</p> <p>FCC (FCC Designation No.: CN1187) UL Verification Services (Guangzhou) Co., Ltd. Song Shan Lake Branch. Has been recognized to perform compliance testing on equipment subject to the Commission's Declaration of Conformity (DoC) and Certification rules</p> <p>ISED (Company No.: 21320) UL Verification Services (Guangzhou) Co., Ltd. Song Shan Lake Branch. has been registered and fully described in a report filed with ISED. The Company Number is 21320 and the test lab Conformity Assessment Body Identifier (CABID) is CN0046.</p> <p>VCCI (Registration No.: G-20019, R-20004, C-20012 and T-20011) UL Verification Services (Guangzhou) Co., Ltd. Song Shan Lake Branch. has been assessed and proved to be in compliance with VCCI, the Membership No. is 3793. Facility Name: Chamber D, the VCCI registration No. is G-20019 and R-20004 Shielding Room B , the VCCI registration No. is C-20012 and T-20011</p>
---------------------------	---

Note 1: All tests measurement facilities use to collect the measurement data are located at Building 10, Innovation Technology Park, Song Shan Lake Hi tech Development Zone, Dongguan, 523808, China

Note 2: The test anechoic chamber in UL Verification Services (Guangzhou) Co., Ltd. Song Shan Lake Branch had been calibrated and compared to the open field sites and the test anechoic chamber is shown to be equivalent to or worst case from the open field site.

Note 3: For below 30 MHz, lab had performed measurements at test anechoic chamber and comparing to measurements obtained on an open field site. And these measurements below 30 MHz had been correlated to measurements performed on an OFS.



4. CALIBRATION AND UNCERTAINTY

4.1. MEASURING INSTRUMENT CALIBRATION

The measuring equipment utilized to perform the tests documented in this report has been calibrated in accordance with the manufacturer's recommendations and is traceable to recognize national standards.

4.2. MEASUREMENT UNCERTAINTY

Where relevant, the following measurement uncertainty levels have been estimated for tests performed on the apparatus:

Test Item	Uncertainty
Conduction emission	3.62 dB
Radiated Emission (Included Fundamental Emission) (9 kHz ~ 30 MHz)	2.2 dB
Radiated Emission (Included Fundamental Emission) (30 MHz ~ 1 GHz)	4.00 dB
Radiated Emission (Included Fundamental Emission) (1 GHz to 40 GHz)	5.78 dB (1 GHz-18 GHz)
	5.23dB (18 GHz-26 GHz)
	5.64 dB (26 GHz-40 GHz)
Note: This uncertainty represents an expanded uncertainty expressed at approximately the 95 % confidence level using a coverage factor of k=2.	



5. EQUIPMENT UNDER TEST

5.1. DESCRIPTION OF EUT

EUT Name	IEEE 802.11a/b/g/n/ac 2T2R USB Wi-Fi Module Integrated BT 2.1+EDR/4.2/5.1
Model	SKO.WB663U.3
Radio Technology	IEEE802.11a 20 IEEE802.11n HT20/n HT40 IEEE802.11ac VHT20/ac VHT40/ac VHT80
Operation frequency	UNII-1: 5150 ~ 5250 MHz UNII-2A: 5250 ~ 5350 MHz UNII-2C: 5470 ~ 5725 MHz UNII-3: 5725 ~ 5850 MHz
Modulation	IEEE 802.11a 20: OFDM (64QAM, 16QAM, QPSK, BPSK) IEEE 802.11n HT20: OFDM (64QAM, 16QAM, QPSK, BPSK) IEEE 802.11n HT40: OFDM (64QAM, 16QAM, QPSK, BPSK) IEEE 802.11ac VHT20: OFDM (256QAM, 64QAM, 16QAM, QPSK, BPSK) IEEE 802.11ac VHT40: OFDM (256QAM, 64QAM, 16QAM, QPSK, BPSK) IEEE 802.11ac VHT80: OFDM (256QAM, 64QAM, 16QAM, QPSK, BPSK)
Supply Voltage	5V DC



5.2. MAXIMUM OUTPUT POWER

UNII-1 BAND(FCC&ISED)

IEEE Std. 802.11	Frequency (MHz)	Maximum Average Conducted Power (dBm)	Max Average EIRP (dBm)
a 20	5150 ~ 5250	14.38	16.41
n HT20		12.76	14.79
n HT40		13.16	15.19
ac VHT20		12.85	14.88
ac VHT40		13.04	15.07
ac VHT80		16.71	18.74

UNII-2A BAND(FCC&ISED)

IEEE Std. 802.11	Frequency (MHz)	Maximum Average Conducted Power (dBm)
a 20	5250 ~ 5350	13.69
n HT20		12.77
n HT40		12.90
ac VHT20		12.67
ac VHT40		13.00
ac VHT80		16.78

UNII-2C BAND(FCC&ISED)

IEEE Std. 802.11	Frequency (MHz)	Maximum Average Conducted Power (dBm)
a 20	5470 ~ 5725	14.48
n HT20		13.71
n HT40		13.69
ac VHT20		13.66
ac VHT40		13.81
ac VHT80		16.90

UNII-3 BAND(FCC&ISED)

IEEE Std. 802.11	Frequency (MHz)	Maximum Average Conducted Power (dBm)
a 20	5725 ~ 5850	14.08
n HT20		12.45
n HT40		12.57
ac VHT20		12.59
ac VHT40		12.79
ac VHT80		16.14



5.3. CHANNEL LIST

UNII-1 (For Bandwidth=20MHz)		UNII-1 (For Bandwidth=40MHz)		UNII-1 (For Bandwidth=80MHz)	
Channel	Frequency (MHz)	Channel	Frequency (MHz)	Channel	Frequency (MHz)
36	5180	38	5190	42	5210
40	5200	46	5230		
44	5220				
48	5240				

UNII-2A (For Bandwidth=20MHz)		UNII-2A (For Bandwidth=40MHz)		UNII-2A (For Bandwidth=80MHz)	
Channel	Frequency (MHz)	Channel	Frequency (MHz)	Channel	Frequency (MHz)
52	5260	54	5270	58	5290
56	5280	62	5310		
60	5300				
64	5320				

UNII-2C (For Bandwidth=20MHz)		UNII-2C (For Bandwidth=40MHz)		UNII-2C (For Bandwidth=80MHz)	
Channel	Frequency (MHz)	Channel	Frequency (MHz)	Channel	Frequency (MHz)
100	5500	102	5510	106	5530
104	5520	110	5550	122	5610
108	5540	118	5590	138	5690
112	5560	126	5630		
116	5580	134	5670		
120	5600	142	5710		
124	5620				
128	5640				
132	5660				
136	5680				
140	5700				
144	5720				

UNII-3		UNII-3		UNII-3	
Channel	Frequency (MHz)	Channel	Frequency (MHz)	Channel	Frequency (MHz)
149	5745	151	5755	155	5775
153	5765	159	5795		
157	5785				
161	5805				
165	5825				

Note: All channels in the 5600-5650MHz band was not operational in Canada.



5.4. TEST CHANNEL CONFIGURATION

UNII-1 Test Channel Configuration		
IEEE Std.	Test Channel Number	Frequency
802.11a 20	CH 36(Low Channel), CH 40(MID Channel), CH 48(High Channel)	5180 MHz, 5200 MHz, 5240 MHz
802.11n HT20	CH 36(Low Channel), CH 40(MID Channel), CH 48(High Channel)	5180 MHz, 5200 MHz, 5240 MHz
802.11n HT40	CH 38(Low Channel), CH 46(High Channel)	5190 MHz, 5230 MHz
802.11ac VHT20	CH 36(Low Channel), CH 40(MID Channel), CH 48(High Channel)	5180 MHz, 5200 MHz, 5240 MHz
802.11ac VHT40	CH 38(Low Channel), CH 46(High Channel)	5190 MHz, 5230 MHz
802.11ac VHT80	CH 42(Low Channel)	5210 MHz

UNII-2A Test Channel Configuration		
IEEE Std.	Test Channel Number	Frequency
802.11a 20	CH 52(Low Channel), CH 56(MID Channel), CH 64(High Channel)	5260 MHz, 5280 MHz, 5320 MHz
802.11n HT20	CH 52(Low Channel), CH 56(MID Channel), CH 64(High Channel)	5260 MHz, 5280 MHz, 5320 MHz
802.11n HT40	CH 54(Low Channel), CH 62(High Channel)	5270 MHz, 5310 MHz
802.11ac VHT20	CH 52(Low Channel), CH 56(MID Channel), CH 64(High Channel)	5260 MHz, 5280 MHz, 5320 MHz
802.11ac VHT40	CH 54(Low Channel), CH 62(High Channel)	5270 MHz, 5310 MHz
802.11ac VHT80	CH 58(Low Channel)	5290 MHz

UNII-2C Test Channel Configuration		
IEEE Std.	Test Channel Number	Frequency
802.11a 20	CH 100(Low Channel), CH 120(MID Channel), CH 140(High Channel)	5500 MHz, 5600 MHz, 5700 MHz
802.11n VHT20	CH 100(Low Channel), CH 120(MID Channel), CH 140(High Channel)	5500 MHz, 5600 MHz, 5700 MHz
802.11n VHT40	CH 102(Low Channel), CH 118(MID Channel), CH 134(High Channel)	5510 MHz, 5590 MHz, 5670 MHz
802.11ac VHT20	CH 100(Low Channel), CH 120(MID Channel), CH 140(High Channel)	5500MHz, 5600 MHz, 5700MHz
802.11ac VHT40	CH 102(Low Channel), CH 118(MID Channel), CH 134(High Channel)	5510 MHz, 5590 MHz, 5670 MHz
802.11ac VHT80	CH 102(Low Channel), CH 122(High Channel)	5530 MHz, 5610 MHz



UNII-3 Test Channel Configuration		
IEEE Std.	Test Channel Number	Frequency
802.11a 20	CH 149(Low Channel), CH 157(MID Channel), CH 165(High Channel)	5745 MHz, 5785 MHz, 5825 MHz
802.11n HT20	CH 149(Low Channel), CH 157(MID Channel), CH 165(High Channel)	5745 MHz, 5785 MHz, 5825 MHz
802.11n HT40	CH 151(Low Channel), CH 159(High Channel)	5755MHz, 5795MHz
802.11ac VHT20	CH 149(Low Channel), CH 157(MID Channel), CH 165(High Channel)	5745 MHz, 5785 MHz, 5825 MHz
802.11ac VHT40	CH 151(Low Channel), CH 159(High Channel)	5755 MHz, 5795 MHz
802.11ac VHT80	CH 155(Low Channel)	5775 MHz

5.5. DESCRIPTION OF AVAILABLE ANTENNAS

Antenna No.	Frequency (MHz)	Antenna Type	Max Antenna Gain (dBi)
1	5150-5850	FPC antenna	2.01
2	5150-5850	FPC antenna	2.03

Note: Directional gain= $10 \log [(10^{G1/20} + 10^{G2/20})^2 / N_{ANT}] = 5.03\text{dBi}$

G_{ANT} : Average of the Antenna Gain

N_{ANT} : Antenna numbers

Note: The value of the antenna gain was declared by customer.

IEE Std. 802.11	Transmit and Receive Mode	Description
802.11a	<input checked="" type="checkbox"/> 2TX, 2RX	ANT 1 and ANT 2 can be used as transmitting/receiving antenna.
802.11n HT20	<input checked="" type="checkbox"/> 2TX, 2RX	ANT 1 and ANT 2 can be used as transmitting/receiving antenna.
802.11n HT40	<input checked="" type="checkbox"/> 2TX, 2RX	ANT 1 and ANT 2 can be used as transmitting/receiving antenna.
802.11ac VHT20	<input checked="" type="checkbox"/> 2TX, 2RX	ANT 1 and ANT 2 can be used as transmitting/receiving antenna.
802.11ac VHT40	<input checked="" type="checkbox"/> 2TX, 2RX	ANT 1 and ANT 2 can be used as transmitting/receiving antenna.
802.11ac VHT80	<input checked="" type="checkbox"/> 2TX, 2RX	ANT 1 and ANT 2 can be used as transmitting/receiving antenna.

Note:

1.BT&WLAN 2.4G, BT & WLAN 5G, WLAN 2.4G & WLAN 5G can't transmit simultaneously.
(declared by client)

5.6. THE WORSE CASE POWER SETTING PARAMETER

The Worse Case Power Setting Parameter	
Test Software	QA tool

UNII-1/ UNII-2A/ UNII-2C/ UNII-3

Mode	Rate	Channel	Soft set value	
			ANT 1	ANT 2
11a 20	6M	All	Default	Default
11n HT20	MCS0		Default	Default
11n HT40	MCS0		Default	Default
11ac VHT20	MCS0		Default	Default
11ac VHT40	MCS0		Default	Default
11ac VHT80	MCS0		Default	Default



5.7. THE WORSE CASE CONFIGURATIONS

The EUT was tested in the following configuration(s):

Controlled in test mode using a software application on the EUT supplied by customer. The application was used to enable a continuous transmission and to select the mode, test channels, bandwidth, data rates as required.

Test channels referring to section 5.4.

Maximum power setting referring to section 5.6.

Worst case Data Rates declared by the customer:

802.11a 20 mode: 6 Mbps
802.11n HT20 mode: MCS0
802.11n HT40 mode: MCS0
802.11ac VHT20 mode: MCS0
802.11ac VHT40 mode: MCS0
802.11ac VHT80 mode: MCS0

802.11ac VHT20 and VHT40 mode are different from 802.11nHT20 and HT40 only in control messages, so for these 4 modes, only 802.11ac VHT20 and 802.11ac VHT40 worst case power modes radiated emission test data are recorded in the report .

802.11ac&n SISO mode and MIMO mode have the same power setting, so only the worst case power mode(MIMO) will be record in the report.

The EUT has 2 separate antennas which correspond to 2 separate antenna ports. Core 1 and Core 2 correspond to antenna 1 and antenna 2 respectively.

Antenna 1 and Antenna 2 have the same power setting, and the power test data are the same. (Declared by customer.)

The measured additional path loss was included in any path loss calculations for all RF cable used during tested.

Conducted output power, power spectral density tests separately on each port with all supported SISO & MIMO port combinations.

Radiated emissions tests were performed with the MIMO modes. These were found to be the worst modulation scheme with regards to emissions after preliminary investigations and, as this mode emits the highest conducted output power level, it was deemed to be the worst case.

The EUT support rotating antennas, we have done pre-tests under different angle combinations. so only the worst measurement position (X axis) was recorded in the report only the worst as shown in the setup photo

5.8. DESCRIPTION OF TEST SETUP

SUPPORT EQUIPMENT

Item	Equipment	Brand Name	Model Name	Remarks
1	Laptop	ThinkPad	X230i	/
2	Adaptor	Lenovo	ADLX65YCC3D	Input:AC100-240V ~1.8A 50-60Hz
3	USB TO UART	/	/	/

I/O CABLES

Cable No	Port	Connector Type	Cable Type	Cable Length(m)	Remarks
1	USB	/	/	1.0	/

ACCESSORIES

Item	Accessory	Brand Name	Model Name	Description
1	/	/	/	/

TEST SETUP

The EUT can work in engineering mode with a software through a Laptop.

SETUP DIAGRAM FOR TESTS

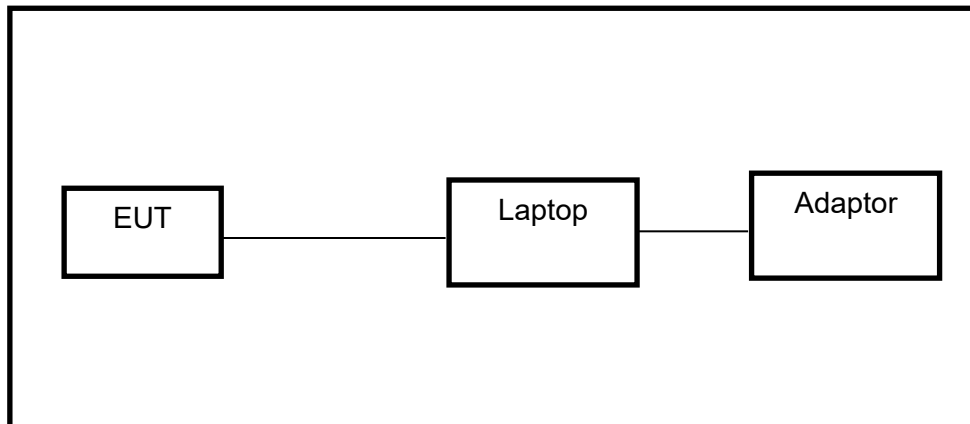

**6. MEASURING INSTRUMENT AND SOFTWARE USED**

Conducted Emissions					
Equipment	Manufacturer	Model No.	Serial No.	Last Cal.	Due Date
EMI Test Receiver	R&S	ESR3	101961	Nov. 12, 2020	Nov. 11, 2021
Two-Line V-Network	R&S	ENV216	101983	Nov. 12, 2020	Nov. 11, 2021
Software					
Description			Manufacturer	Name	Version
Test Software for Conducted Emissions			Farad	EZ-EMC	Ver. UL-3A1

Radiated Emissions					
Equipment	Manufacturer	Model No.	Serial No.	Last Cal.	Due Date
MXE EMI Receiver	KESIGHT	N9038A	MY56400036	Nov. 12, 2020	Nov. 11, 2021
Hybrid Log Periodic Antenna	TDK	HLP-3003C	130959	April 24, 2020	April 23, 2023
Preamplifier	HP	8447D	2944A09099	Nov. 12, 2020	Nov. 11, 2021
EMI Measurement Receiver	R&S	ESR26	101377	Nov. 12, 2020	Nov. 11, 2021
Horn Antenna	TDK	HRN-0118	130939	Sept. 17, 2018	Sept. 17, 2021
Preamplifier	TDK	PA-02-0118	TRS-305-00067	Nov. 20, 2020	Nov. 19, 2021
Horn Antenna	Schwarzbeck	BBHA9170	#697	July 20, 2021	July 19, 2024
Preamplifier	TDK	PA-02-2	TRS-307-00003	Nov. 12, 2020	Nov. 11, 2021
Preamplifier	TDK	PA-02-3	TRS-308-00002	Nov. 12, 2020	Nov. 11, 2021
Loop antenna	Schwarzbeck	1519B	00008	Jan.17, 2019	Jan.17,2022
Preamplifier	TDK	PA-02-001-3000	TRS-302-00050	Nov. 12, 2020	Nov. 11, 2021
Preamplifier	Mini-Circuits	ZX60-83LN-S+	SUP01201941	Nov. 20, 2020	Nov. 19, 2021
Highpass Filter	Wainwright	WHKX10-5850-6500-1800-40SS	4	Nov. 12, 2020	Nov. 11, 2021
Band Reject Filter	Wainwright	WRCJV12-5695-5725-5850-5880-40SS	4	Nov. 12, 2020	Nov. 11, 2021
Band Reject Filter	Wainwright	WRCJV20-5120-5150-5350-5380-60SS	2	Nov. 12, 2020	Nov. 11, 2021



Band Reject Filter	Wainwright	WRCJV20-5440-5470-5725-5755-60SS	1	Nov. 12, 2020	Nov. 11, 2021
Software					
Description		Manufacturer		Name	Version
Test Software for Radiated Emissions		Farad		EZ-EMC	Ver. UL-3A1

Tonsend RF Test System					
Equipment	Manufacturer	Model No.	Serial No.	Last Cal.	Due. Date
Wideband Radio Communication Tester	R&S	CMW500	155523	Nov.20,2020	Nov.19,2021
PXA Signal Analyzer	Keysight	N9030A	MY55410512	Nov.20,2020	Nov.19,2021
MXG Vector Signal Generator	Keysight	N5182B	MY56200284	Nov.20,2020	Nov.19,2021
MXG Vector Signal Generator	Keysight	N5172B	MY56200301	Nov.20,2020	Nov.19,2021
DC power supply	Keysight	E3642A	MY55159130	Nov.24,2020	Nov.23,2021
Temperature & Humidity Chamber	SANMOOD	SG-80-CC-2	2088	Nov.20,2020	Nov.19,2021
Software					
Description		Manufacturer		Name	Version
Tonsend SRD Test System		Tonsend		JS1120-3 RF Test System	2.6.77.0518

Other Instruments					
Equipment	Manufacturer	Model No.	Serial No.	Last Cal.	Next Cal.
Power sensor, Power Meter	R&S	OSP120	100921	Mar.23,2020	Mar.22,2021

7. ANTENNA PORT TEST RESULTS

7.1. ON TIME AND DUTY CYCLE

LIMITS

None; for reporting purposes only.

PROCEDURE

Refer to KDB 789033 D02 General U-NII Test Procedures New Rules v02r01 section II.B.

The zero-span mode on a spectrum analyzer or EMI receiver, if the response time and spacing between bins on the sweep are sufficient to permit accurate measurements of the on and off times of the transmitted signal. Set the center frequency of the instrument to the center frequency of the transmission. Set $RBW \geq EBW$ if possible; otherwise, set RBW to the largest available value. Set $VBW \geq RBW$. Set detector = peak or average. The zero-span measurement method shall not be used unless both RBW and VBW are $> 50/T$, where T is defined in II.B.1.a), and the number of sweep points across duration T exceeds 100. (For example, if VBW and/or RBW are limited to 3 MHz, then the zero-span method of measuring duty cycle shall not be used if $T \leq 16.7$ microseconds.)

TEST SETUP

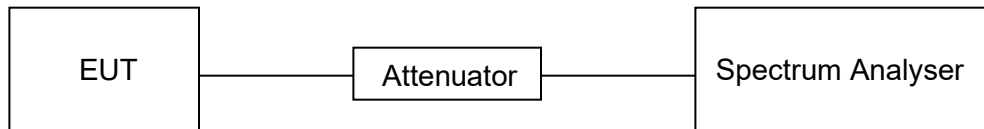

TEST ENVIRONMENT

Temperature	26.8 °C	Relative Humidity	62.3 %
Atmosphere Pressure	101 kPa	Test Voltage	DC 5 V

RESULTS

Please refer to appendix D.

7.2. 6/26 dB EMISSION BANDWIDTH AND 99 % OCCUPIED BANDWIDTH

LIMITS

CFR 47 FCC Part15, Subpart E ISED RSS-247 ISSUE 2		
Test Item	Limit	Frequency Range (MHz)
26 dB Emission Bandwidth	For reporting purposes only.	5150 ~ 5250
26 dB Emission Bandwidth	For reporting purposes only.	5250 ~ 5350
26 dB Emission Bandwidth	For reporting purposes only.	5470 ~ 5725 (For FCC) 5470 ~ 5600 (For ISED) 5650 ~ 5725 (For ISED)
6 dB Emission Bandwidth	The minimum 6 dB emission bandwidth shall be 500 kHz.	5725 ~ 5850
99 % Occupied Bandwidth	For reporting purposes only.	5150 ~ 5825 (For ISED)

TEST PROCEDURE

Refer to KDB 789033 D02 General U-NII Test Procedures New Rules v02r01 section II.C1. for 26 dB Emission Bandwidth; section II.C2. for 6 dB Emission Bandwidth; section II.D. for 99 % Occupied Bandwidth.

Connect the EUT to the spectrum analyser and use the following settings:

Center Frequency	The center frequency of the channel under test
Detector	Peak
RBW	For 6 dB Emission Bandwidth: RBW=100 kHz For 26 dB Emission bandwidth: approximately 1 % of the EBW. For 99 % Occupied Bandwidth: approximately 1 % ~ 5 % of the OBW.
VBW	For 6 dB Bandwidth: $\geq 3 \times \text{RBW}$ For 26 dB Bandwidth: $> \text{RBW}$ For 99 % Bandwidth: $> 3 \times \text{RBW}$
Trace	Max hold
Sweep	Auto couple

- a) Use the 99 % power bandwidth function of the instrument, allow the trace to stabilize and report the measured bandwidth.
- b) Allow the trace to stabilize and measure the maximum width of the emission that is constrained by the frequencies associated with the two outermost amplitude points (upper and lower frequencies) that are attenuated by 6/26 dB relative to the maximum level measured in the fundamental emission.

Calculation for 99 % Bandwidth of UNII-2C and UNII-3 Straddle Channel:

For Example: Fundamental Frequency: 5720 MHz

99 % OBW: 21.00 MHz

Turning Frequency: 5725 MHz

99 % Bandwidth of UNII-2C Band Portion = $(5725-(5720-(21.00/2))) = 15.50$ MHz

99 % Bandwidth of UNII-3 Band Portion = $(5720+(21.00/2)-5725) = 5.50$ MHz

Calculation for 26 dB Bandwidth of UNII-2C Straddle Channel:

For Example: Fundamental frequency: 5720 MHz

26 dB BW: 20.00 MHz

FL: 5710.16 MHz

FH: 5730.16 MHz

Turning Frequency: 5725 MHz

26 dB Bandwidth of UNII-2C Band Portion = $5725-5710.16=14.84$ MHz

Calculation for 6dB Bandwidth of UNII-3 Straddle Channel:

For Example: Fundamental frequency: 5720 MHz

6 dB BW: 16.44 MHz

FL: 5711.76 MHz

FH: 5728.2 MHz

Turning Frequency: 5725 MHz

6 dB Bandwidth of UNII-3 band Portion = $5728.2-5725=3.2$ MHz

TEST SETUP

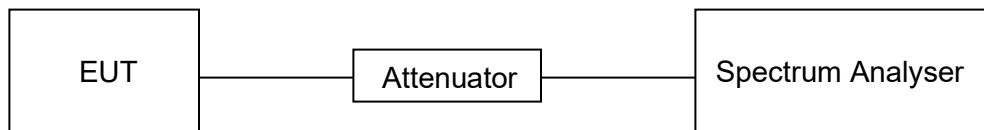

TEST ENVIRONMENT

Temperature	26.8 °C	Relative Humidity	62.3 %
Atmosphere Pressure	101 kPa	Test Voltage	DC 5 V

RESULTS

Please refer to Appendix A1&A2&A3.



7.3. CONDUCTED OUTPUT POWER

LIMITS

CFR 47 FCC Part15, Subpart E		
Test Item	Limit	Frequency Range (MHz)
Conducted Output Power	<input type="checkbox"/> Outdoor Access Point: 1 W (30 dBm) <input type="checkbox"/> Indoor Access Point: 1 W (30 dBm) <input type="checkbox"/> Fixed Point-To-Point Access Points: 1 W (30 dBm) <input checked="" type="checkbox"/> Client Devices: 250 mW (24 dBm)	5150 ~ 5250
	Shall not exceed the lesser of 250 mW (24dBm) or 11 dBm + 10 log B, where B is the 26 dB emission bandwidth in megahertz.	5250 ~ 5350 5470 ~ 5725
	Shall not exceed 1 Watt (30 dBm).	5725 ~ 5850

ISED RSS-247 ISSUE 2		
Test Item	Limit	Frequency Range (MHz)
Conducted Output Power or e.i.r.p.	The maximum e.i.r.p. shall not exceed 200 mW (23 dBm) or 10 + 10 log ₁₀ B, dBm, whichever power is less. B is the 99 % emission bandwidth in megahertz.	5150 ~ 5250
	a. The maximum conducted output power shall not exceed 250 mW (24 dBm) or 11 + 10 log ₁₀ B dBm, whichever is less. b. The maximum e.i.r.p. shall not exceed 1.0 W (30 dBm) or 17 + 10 log ₁₀ B dBm, whichever is less. B is the 99 % emission bandwidth in megahertz. Note that devices with a maximum e.i.r.p. greater than 500 mW shall implement TPC in order to have the capability to operate at least 6 dB below the maximum permitted e.i.r.p. of 1 W.	5250 ~ 5350 5470 ~ 5600 5650 ~ 5725
	Shall not exceed 1 Watt (30 dBm). The e.i.r.p. shall not exceed 4 W	5725 ~ 5850

Note:

The above limits are based upon the maximum antenna gain does not exceed 6 dBi. If transmitting antennas of directional gain greater than 6 dBi are used, the maximum conducted output power shall be reduced by the amount in dB that the directional gain of the antenna exceeds 6 dBi.



TEST PROCEDURE

Refer to KDB 789033 D02 General U-NII Test Procedures New Rules v02r01 section II.E.

Method SA-1 (trace averaging with the EUT transmitting at full power throughout each sweep):

- (i) Set span to encompass the entire emission bandwidth (EBW) (or, alternatively, the entire 99% occupied bandwidth) of the signal.
- (ii) Set RBW = 1 MHz.
- (iii) Set VBW \geq 3 MHz.
- (iv) Number of points in sweep $\geq 2 \times$ span / RBW. (This ensures that bin-to-bin spacing is \leq RBW/2, so that narrowband signals are not lost between frequency bins.)
- (v) Sweep time = auto.
- (vi) Detector = power averaging (rms), if available. Otherwise, use sample detector mode.
- (vii) If transmit duty cycle $<$ 98 %, use a video trigger with the trigger level set to enable triggering only on full power pulses. Transmitter must operate at maximum power control level for the entire duration of every sweep. If the EUT transmits continuously (i.e., with no off intervals) or at duty cycle \geq 98 %, and if each transmission is entirely at the maximum power control level, then the trigger shall be set to "free run."
- (viii) Trace average at least 100 traces in power averaging (rms) mode.
- (ix) Compute power by integrating the spectrum across the EBW (or, alternatively, the entire 99% occupied bandwidth) of the signal using the instrument's band power measurement function with band limits set equal to the EBW (or occupied bandwidth) band edges. If the instrument does not have a band power function, sum the spectrum levels (in power units) at 1 MHz intervals extending across the EBW (or, alternatively, the entire 99% occupied bandwidth) of the spectrum.

Method PM (Measurement using an RF average power meter):

- (i) Measurements may be performed using a wideband RF power meter with a thermocouple detector or equivalent if all of the following conditions are satisfied:
 - a. The EUT is configured to transmit continuously or to transmit with a constant duty cycle.
 - b. At all times when the EUT is transmitting, it must be transmitting at its maximum power control level.
 - c. The integration period of the power meter exceeds the repetition period of the transmitted signal by at least a factor of five.
- (ii) If the transmitter does not transmit continuously, measure the duty cycle, x , of the transmitter output signal as described in II.B.
- (iii) Measure the average power of the transmitter. This measurement is an average over both the on and off periods of the transmitter.
- (iv) Adjust the measurement in dBm by adding $10 \log (1/x)$ where x is the duty cycle (e.g., $10 \log (1/0.25)$ if the duty cycle is 25 %).

Method PM-G (Measurement using a gated RF average power meter):

Measurements may be performed using a wideband gated RF power meter provided that the gate parameters are adjusted such that the power is measured only when the EUT is transmitting at its maximum power control level. Since the measurement is made only during the ON time of the transmitter, no duty cycle correction factor is required.

Straddle channel power was measured using spectrum analyzer.



TEST SETUP

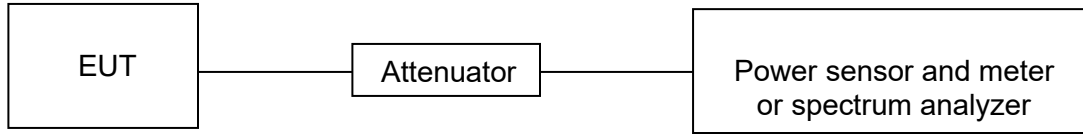

TEST ENVIRONMENT

Temperature	26.8 °C	Relative Humidity	62.3 %
Atmosphere Pressure	101 kPa	Test Voltage	DC 5 V

RESULTS

Please refer to Appendix B.



7.4. POWER SPECTRAL DENSITY

LIMITS

CFR 47 FCC Part15, Subpart E		
Test Item	Limit	Frequency Range (MHz)
Power Spectral Density	<input type="checkbox"/> Outdoor Access Point: 17 dBm/MHz <input type="checkbox"/> Indoor Access Point: 17 dBm/MHz <input type="checkbox"/> Fixed Point-To-Point Access Points: 17 dBm/MHz <input checked="" type="checkbox"/> Client Devices: 11 dBm/MHz	5150 ~ 5250
	11 dBm/MHz	5250 ~ 5350 5470 ~ 5725
	30 dBm/500kHz	5725 ~ 5850

ISED RSS-247 ISSUE 2		
Test Item	Limit	Frequency Range (MHz)
Power Spectral Density	The e.i.r.p. spectral density shall not exceed 10 dBm in any 1.0 MHz band.	5150 ~ 5250
	The power spectral density shall not exceed 11 dBm in any 1.0 MHz band.	5250 ~ 5350 5470 ~ 5600 5650 ~ 5725
	30 dBm / 500 kHz	5725 ~ 5850

Note:

The above limits are based upon the maximum antenna gain does not exceed 6 dBi. If transmitting antennas of directional gain greater than 6 dBi are used, maximum power spectral density shall be reduced by the amount in dB that the directional gain of the antenna exceeds 6 dBi.

TEST PROCEDURE

Refer to KDB 789033 D02 General U-NII Test Procedures New Rules v02r01 section II.F.

Connect the EUT to the spectrum analyser and use the following settings:

For U-NII-1, U-NII-2A and U-NII-2C band:

Center Frequency	The center frequency of the channel under test
Detector	RMS
RBW	1 MHz
VBW	$\geq 3 \times \text{RBW}$
Span	Encompass the entire emissions bandwidth (EBW) of the signal
Trace	Max hold
Sweep time	Auto

For U-NII-3:

Center Frequency	The center frequency of the channel under test
Detector	RMS
RBW	500 kHz
VBW	$\geq 3 \times \text{RBW}$
Span	Encompass the entire emissions bandwidth (EBW) of the signal
Trace	Max hold
Sweep time	Auto

Allow trace to fully stabilize and Use the peak search function on the instrument to find the peak of the spectrum and record its value.

Add $10 \log(1/x)$, where x is the duty cycle, to the peak of the spectrum, the result is the Maximum PSD over 1 MHz / 500 kHz reference bandwidth.

TEST SETUP

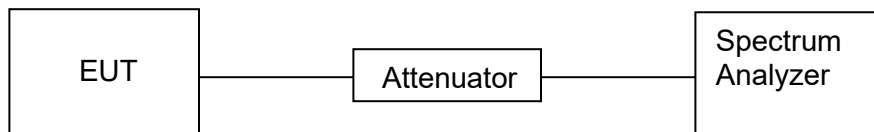

TEST ENVIRONMENT

Temperature	26.8 °C	Relative Humidity	62.3 %
Atmosphere Pressure	101 kPa	Test Voltage	DC 5 V

RESULTS

Please refer to Appendix C.

8. RADIATED TEST RESULTS

LIMITS

Refer to CFR 47 FCC §15.205, §15.209 and §15.407 (b).

Refer to ISED RSS-GEN Clause 8.9, Clause 8.10 and ISED RSS-247 6.2.

Radiation Disturbance Test Limit for FCC (Class B) (9 kHz ~ 1 GHz)

Emissions radiated outside of the specified frequency bands above 30 MHz			
Frequency Range (MHz)	Field Strength Limit (uV/m) at 3 m	Field Strength Limit (dBuV/m) at 3 m	
		Quasi-Peak	
30 - 88	100	40	
88 - 216	150	43.5	
216 - 960	200	46	
Above 960	500	54	
Above 1000	500	Peak	Average
		74	54

FCC Emissions radiated outside of the specified frequency bands below 30 MHz		
Frequency (MHz)	Field strength (microvolts/meter)	Measurement distance (meters)
0.009-0.490	2400/F(kHz)	300
0.490-1.705	24000/F(kHz)	30
1.705-30.0	30	30

ISED General field strength limits at frequencies below 30 MHz

Table 6 – General field strength limits at frequencies below 30 MHz		
Frequency	Magnetic field strength (H-Field) (µA/m)	Measurement distance (m)
9 - 490 kHz ^{Note 1}	6.37/F (F in kHz)	300
490 - 1705 kHz	63.7/F (F in kHz)	30
1.705 - 30 MHz	0.08	30

Note 1: The emission limits for the ranges 9-90 kHz and 110-490 kHz are based on measurements employing a linear average detector.



ISED Restricted bands refer to ISED RSS-GEN Clause 8.10

Table 7 – Restricted frequency bands ^{Note 1}		
MHz	MHz	GHz
0.090 - 0.110	149.9 - 150.05	9.0 - 9.2
0.495 - 0.505	156.52475 - 156.52525	9.3 - 9.5
2.1735 - 2.1905	156.7 - 156.9	10.0 - 12.7
3.020 - 3.026	162.0125 - 167.17	13.25 - 13.4
4.125 - 4.128	167.72 - 173.2	14.47 - 14.5
4.17725 - 4.17775	240 - 285	15.35 - 16.2
4.20725 - 4.20775	322 - 335.4	17.7 - 21.4
5.677 - 5.683	399.9 - 410	22.01 - 23.12
6.215 - 6.218	608 - 614	23.6 - 24.0
6.26775 - 6.26825	900 - 1427	31.2 - 31.8
6.31175 - 6.31225	1435 - 1626.5	36.43 - 36.5
8.291 - 8.294	1645.5 - 1646.5	Above 38.6
8.362 - 8.366	1660 - 1710	
8.37625 - 8.38675	1718.8 - 1722.2	
8.41425 - 8.41475	2200 - 2300	
12.29 - 12.293	2310 - 2390	
12.51975 - 12.52025	2483.5 - 2500	
12.57675 - 12.57725	2655 - 2900	
13.36 - 13.41	3260 - 3267	
16.42 - 16.423	3332 - 3339	
16.69475 - 16.69525	3345.8 - 3358	
16.80425 - 16.80475	3500 - 4400	
25.5 - 25.67	4500 - 5150	
37.5 - 38.25	5350 - 5460	
73 - 74.6	7250 - 7750	
74.8 - 75.2	8025 - 8500	
108 - 138		

Note 1: Certain frequency bands listed in table 7 and in bands above 38.6 GHz are designated for licence-exempt applications. These frequency bands and the requirements that apply to related devices are set out in the 200 and 300 series of RSSs.

FCC Restricted bands of operation refer to FCC §15.205 (a):

MHz	MHz	MHz	GHz
0.090-0.110	16.42-16.423	399.9-410	4.5-5.15
¹ 0.495-0.505	16.69475-16.69525	608-614	5.35-5.46
2.1735-2.1905	16.80425-16.80475	960-1240	7.25-7.75
4.125-4.128	25.5-25.67	1300-1427	8.025-8.5
4.17725-4.17775	37.5-38.25	1435-1626.5	9.0-9.2
4.20725-4.20775	73-74.6	1645.5-1646.5	9.3-9.5
6.215-6.218	74.8-75.2	1660-1710	10.6-12.7
6.26775-6.26825	108-121.94	1718.8-1722.2	13.25-13.4
6.31175-6.31225	123-138	2200-2300	14.47-14.5
8.291-8.294	149.9-150.05	2310-2390	15.35-16.2
8.362-8.366	156.52475-156.52525	2483.5-2500	17.7-21.4
8.37625-8.38675	156.7-156.9	2690-2900	22.01-23.12
8.41425-8.41475	162.0125-167.17	3260-3267	23.6-24.0
12.29-12.293	167.72-173.2	3332-3339	31.2-31.8
12.51975-12.52025	240-285	3345.8-3358	36.43-36.5
12.57675-12.57725	322-335.4	3600-4400	(²)
13.36-13.41			

Note: ¹Until February 1, 1999, this restricted band shall be 0.490-0.510 MHz.

²Above 38.6c

Limits of unwanted/undesirable emission out of the restricted bands refer to CFR 47 FCC §15.407 (b) and ISED RSS-247 6.2.

LIMITS OF RADIATED EMISSION MEASUREMENT (Above 1GHz)		
Frequency Range (MHz)	EIRP Limit	Field Strength Limit (dBuV/m) at 3 m
5150~5250 MHz	PK: -27 (dBm/MHz)	PK:68.2(dBμV/m)
5250~5350 MHz		
5470~5725 MHz		
5725~5850 MHz	PK: -27 (dBm/MHz) *1 PK: 10 (dBm/MHz) *2 PK: 15.6 (dBm/MHz) *3 PK: 27 (dBm/MHz) *4	PK: 68.2(dBμV/m) *1 PK: 105.2 (dBμV/m) *2 PK: 110.8(dBμV/m) *3 PK: 122.2 (dBμV/m) *4
<p>Note:</p> <p>*1 beyond 75 MHz or more above of the band edge.</p> <p>*2 below the band edge increasing linearly to 10 dBm/MHz at 25 MHz above.</p> <p>*3 below the band edge increasing linearly to a level of 15.6 dBm/MHz at 5 MHz above.</p> <p>*4 from 5 MHz above or below the band edge increasing linearly to a level of 27 dBm/MHz at the band edge.</p>		

TEST SETUP AND PROCEDURE

Below 30 MHz

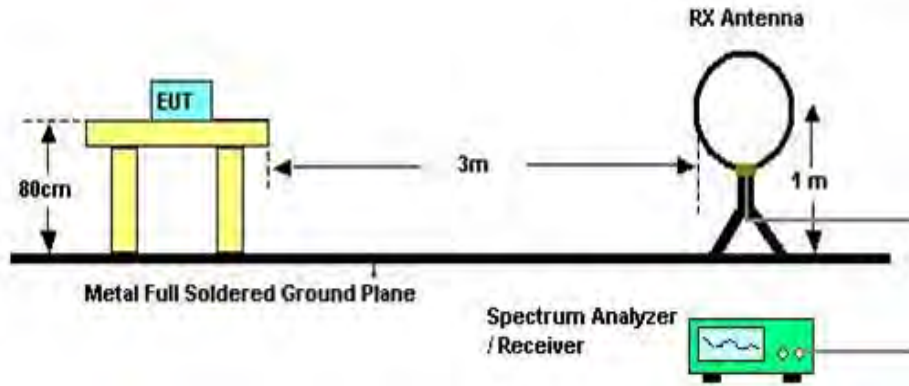

The setting of the spectrum analyser

RBW	200 Hz (From 9 kHz to 0.15 MHz)/ 9 kHz (From 0.15 MHz to 30 MHz)
VBW	200 Hz (From 9 kHz to 0.15 MHz)/ 9 kHz (From 0.15 MHz to 30 MHz)
Sweep	Auto
Trace	Max hold

1. The testing follows the guidelines in ANSI C63.10-2013 clause 11.11.
2. The EUT was arranged to its worst case and then turntable (from 0 degree to 360 degrees) to find the maximum reading. A pre-amp and a high pass filter are used for the test in order to get better signal level. Both Horizontal, Face-on and Face-off polarizations of the antenna are set to make the measurement.
3. The EUT was placed on a turntable with 80 cm above ground.



4. The EUT was set 3 meters from the interference receiving antenna, which was mounted on the top of a 1 m height antenna tower.
5. The radiated emission limits are based on measurements employing a CISPR quasi-peak detector except for the frequency bands 9-90 kHz, 110-490 kHz and above 1000 MHz. Radiated emission limits in these three bands are based on measurements employing an average detector.
6. For measurement below 1 GHz, the initial step in collecting conducted emission data is a spectrum analyzer peak detector mode pre-scanning the measurement frequency range. Significant peaks are then marked and then Quasi Peak and average detector mode re-measured. If the emission level of the EUT measured by the peak detector is 3 dB lower than the applicable limit, the peak emission level will be reported. Otherwise, the emission measurement will be repeated using the quasi-peak and average detector and reported.
7. Although these tests were performed other than open field site, adequate comparison measurements were confirmed against 30 m open field site. Therefore sufficient tests were made to demonstrate that the alternative site produces results that correlate with the ones of tests made in an open field site based on KDB 414788.
8. The limits in CFR 47, Part 15, Subpart C, paragraph 15.209 (a), are identical to those in RSS-GEN Section 8.9, Table 6, since the measurements are performed in terms of magnetic field strength and converted to electric field strength levels (as reported in the table) using the free space impedance of 377Ω . For example, the measurement frequency X kHz resulted in a level of Y dBuV/m, which is equivalent to $Y-51.5 = Z$ dBuA/m, which has the same margin, W dB, to the corresponding RSS-GEN Table 6 limit as it has to be 15.209(a) limit.

Below 1 GHz and above 30 MHz

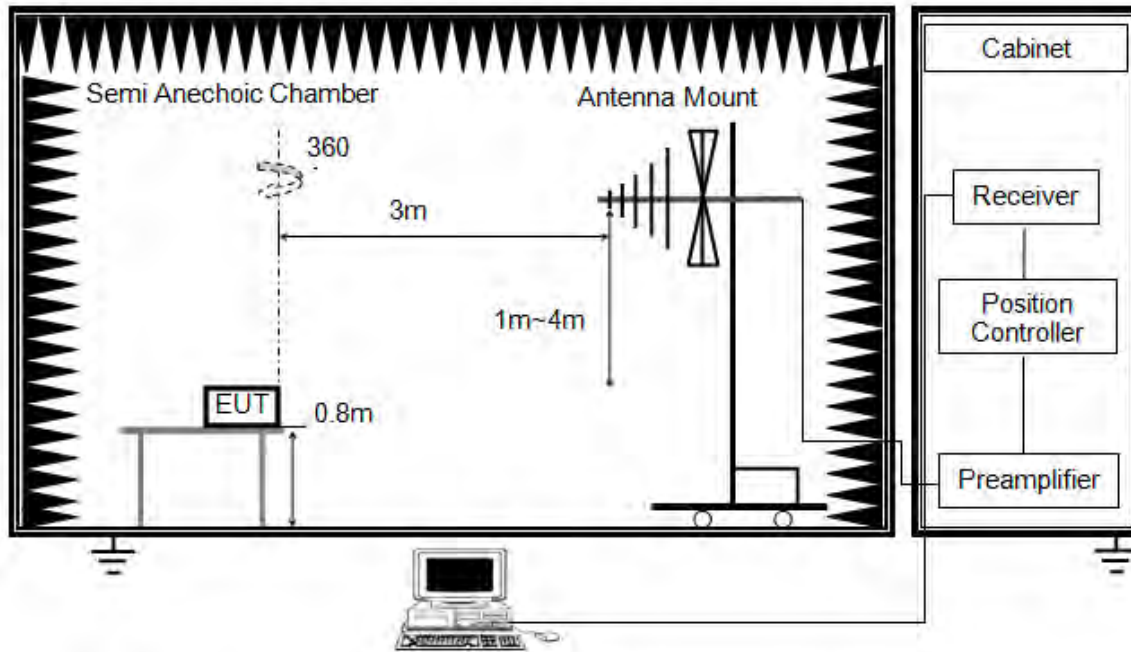

The setting of the spectrum analyser

RBW	120 kHz
VBW	300 kHz
Sweep	Auto
Detector	Peak/QP
Trace	Max hold

1. The testing follows the guidelines in ANSI C63.10-2013 clause 11.11.
2. The EUT was arranged to its worst case and then tune the antenna tower (from 1 m to 4 m) and turntable (from 0 degree to 360 degrees) to find the maximum reading. A pre-amp and a high pass filter are used for the test in order to get better signal level. Both horizontal and vertical polarizations of the antenna are set to make the measurement.
3. The EUT was placed on a turntable with 80 cm above ground.
4. The EUT was set 3 meters from the interference receiving antenna, which was mounted on the top of a variable height antenna tower.
5. For measurement below 1 GHz, the initial step in collecting conducted emission data is a spectrum analyzer peak detector mode pre-scanning the measurement frequency range. Significant peaks are then marked and then Quasi Peak detector mode re-measured. If the emission level of the EUT measured by the peak detector is 3 dB lower than the applicable limit, the peak emission level will be reported. Otherwise, the emission measurement will be repeated using the quasi-peak detector and reported.

Above 1 GHz

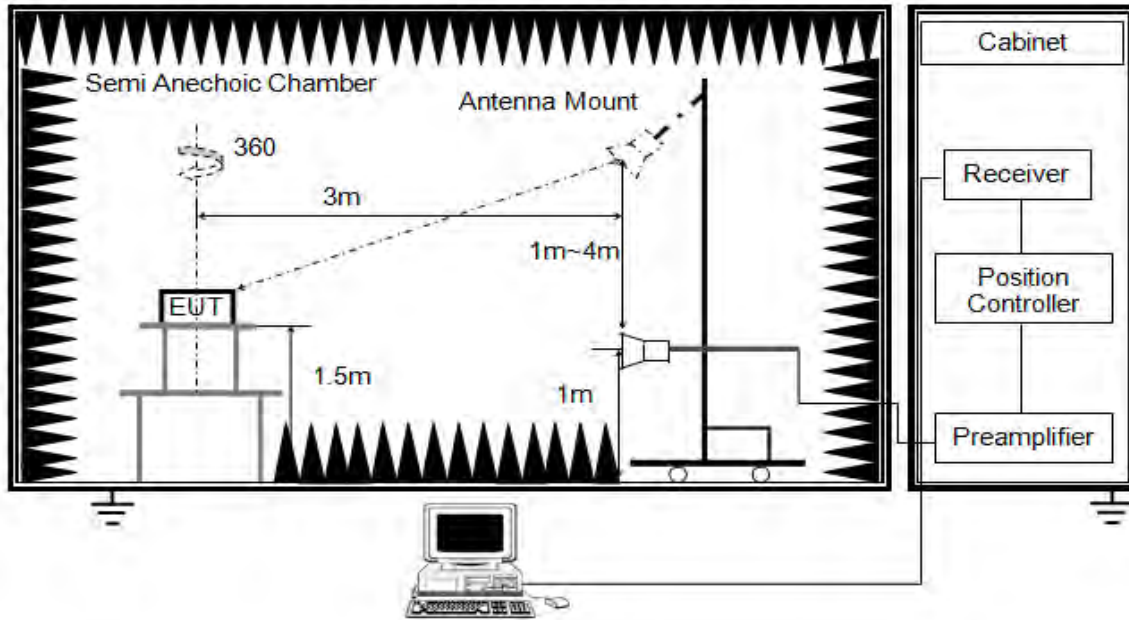

The setting of the spectrum analyser

RBW	1 MHz
VBW	PEAK: 3 MHz AVG: see note 6
Sweep	Auto
Detector	Peak
Trace	Max hold

1. The testing follows the guidelines in KDB 789033 D02 General U-NII Test Procedures New Rules v02r01 section II.G.3 ~ II.G.6.
2. The EUT was arranged to its worst case and then tune the antenna tower (1.5 m) and turntable (from 0 degree to 360 degrees) to find the maximum reading. A pre-amp and a high pass filter are used for the test in order to get better signal level. Both horizontal and vertical polarizations of the antenna are set to make the measurement.
3. The EUT was placed on a turntable with 1.5 m above ground.
4. The EUT was set 3 meters from the interference receiving antenna, which was mounted on the top of a variable height antenna tower.
5. For measurement above 1 GHz, the emission measurement will be measured by the peak detector. This peak level, once corrected, must comply with the limit specified in Section 15.209.
6. For measurements above 1 GHz the resolution bandwidth is set to 1 MHz, then the video bandwidth is set to 3 MHz for peak measurements and 1 MHz resolution bandwidth with 1/T video bandwidth with peak detector for average measurements. For the Duty Cycle please refer to clause 7.1.ON TIME AND DUTY CYCLE.

X axis, Y axis, Z axis positions:

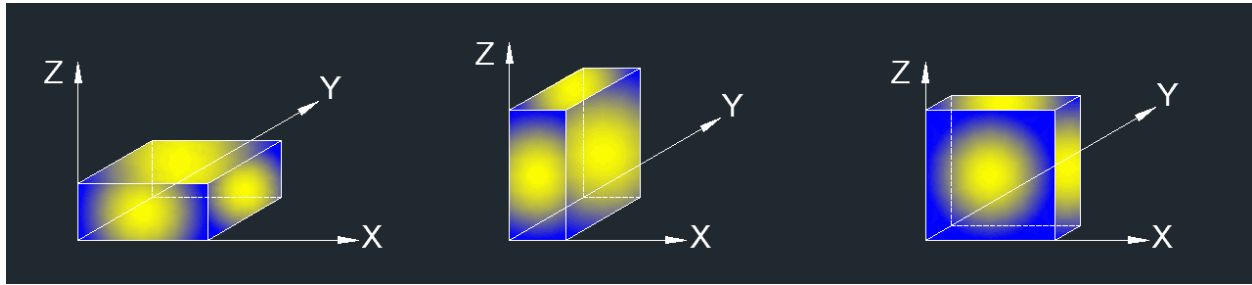

Note 1: For all radiated test, EUT in each of three orthogonal axis emissions had been tested, but only the worst case (X axis) data recorded in the report.

Note 2: The EUT was fully exercised with external accessories during the test. In the case of multiple accessory external ports, an external accessory shall be connected to one of each type of port.

TEST ENVIRONMENT

Temperature	26.1 °C	Relative Humidity	53 %
Atmosphere Pressure	101 kPa	Test Voltage	DC 5 V

RESULTS



8.1. RESTRICTED BANDEDGE

8.1.1. 802.11a 20 SISO MODE

UNII-1 BAND

ANTENNA 1 TEST RESULTS (WORST CASE)

RESTRICTED BANDEDGE (LOW CHANNEL, HORIZONTAL)

PEAK

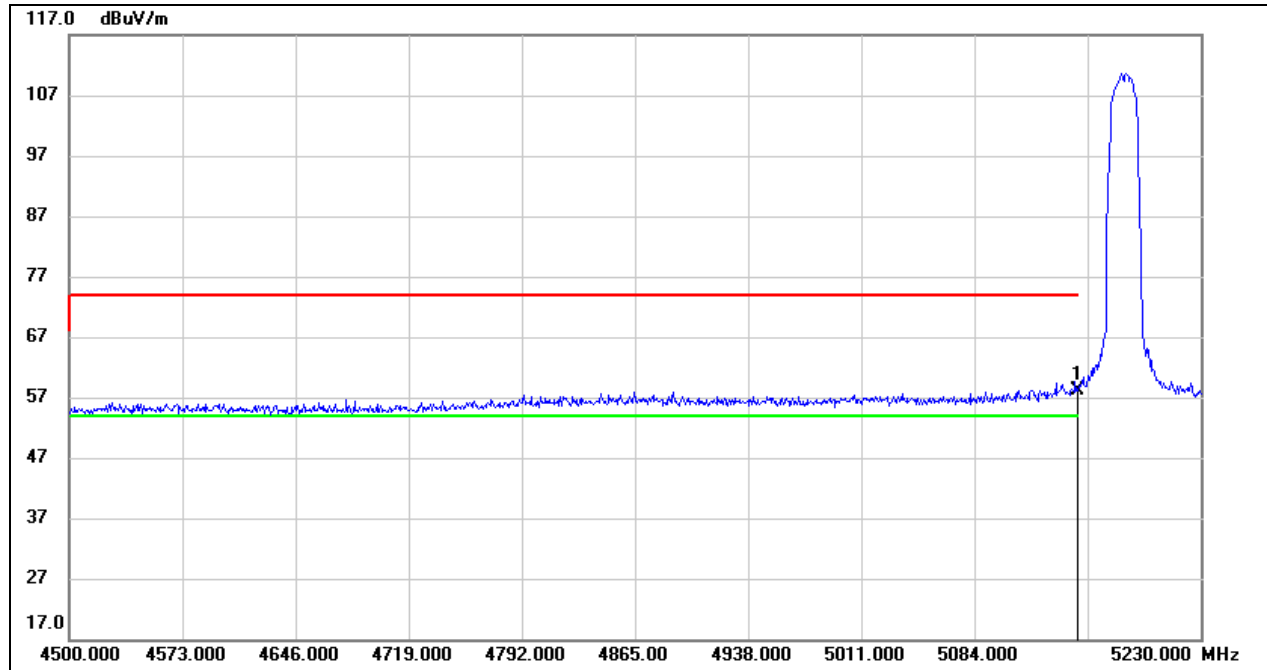

No.	Frequency (MHz)	Reading (dBuV)	Correct (dB/m)	Result (dBuV/m)	Limit (dBuV/m)	Margin (dB)	Remark
1	5150.000	16.96	41.19	58.15	74.00	-15.85	peak

- Note:
1. Measurement = Reading Level + Correct Factor.
 2. If Peak Result complies with AV limit, AV Result is deemed to comply with AV limit.
 3. Peak: Peak detector.
 4. Only the worst data was recorded, if it complies with the limit, the other emissions deemed to comply with the limit.



AVG

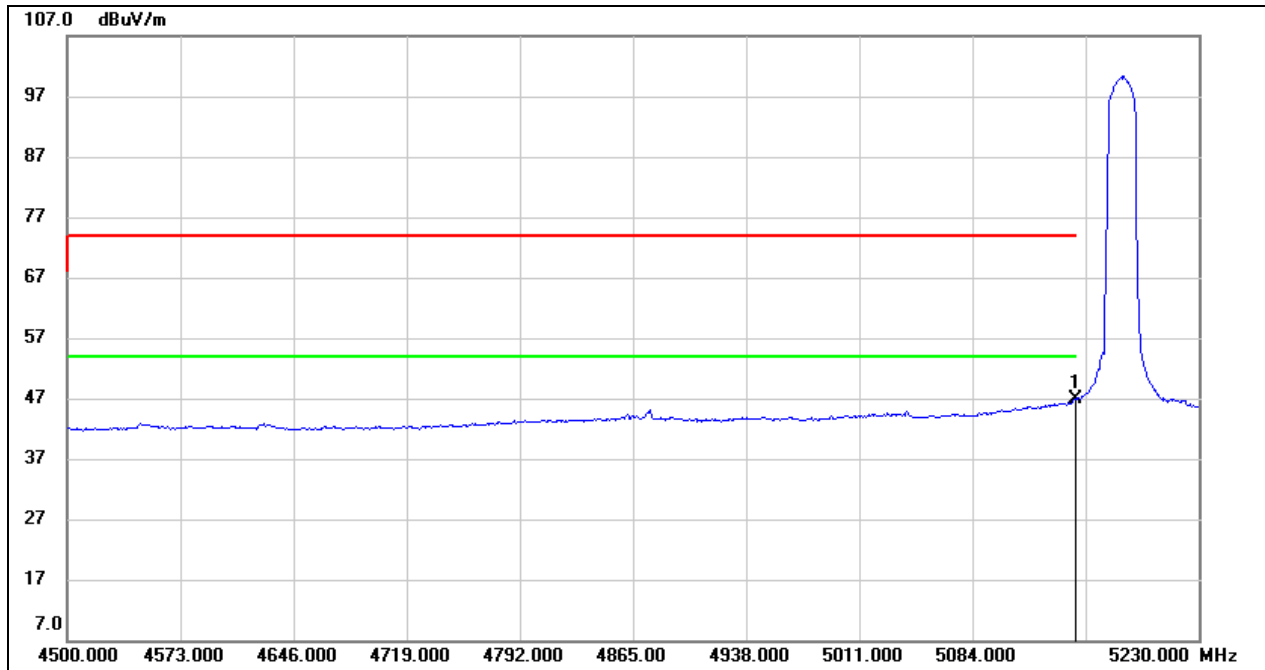

No.	Frequency (MHz)	Reading (dBuV)	Correct (dB/m)	Result (dBuV/m)	Limit (dBuV/m)	Margin (dB)	Remark
1	5150.000	5.77	41.19	46.96	54.00	-7.04	AVG

- Note: 1. Measurement = Reading Level + Correct Factor.
 2. If Peak Result complies with AV limit, AV Result is deemed to comply with AV limit.
 3. AVG: $VBW=1/Ton$, where: Ton is the transmitting duration.
 4. For the transmitting duration, please refer to clause 7.1.
 5. Only the worst data was recorded, if it complies with the limit, the other emissions deemed to comply with the limit.

Note: All the polarities (Vertical & Horizontal) had been tested, only the worst data was recorded in the report.



UNII-2A BAND

ANTENNA 1 TEST RESULTS (WORST CASE)

RESTRICTED BANDEDGE (HIGH CHANNEL, HORIZONTAL)

PEAK

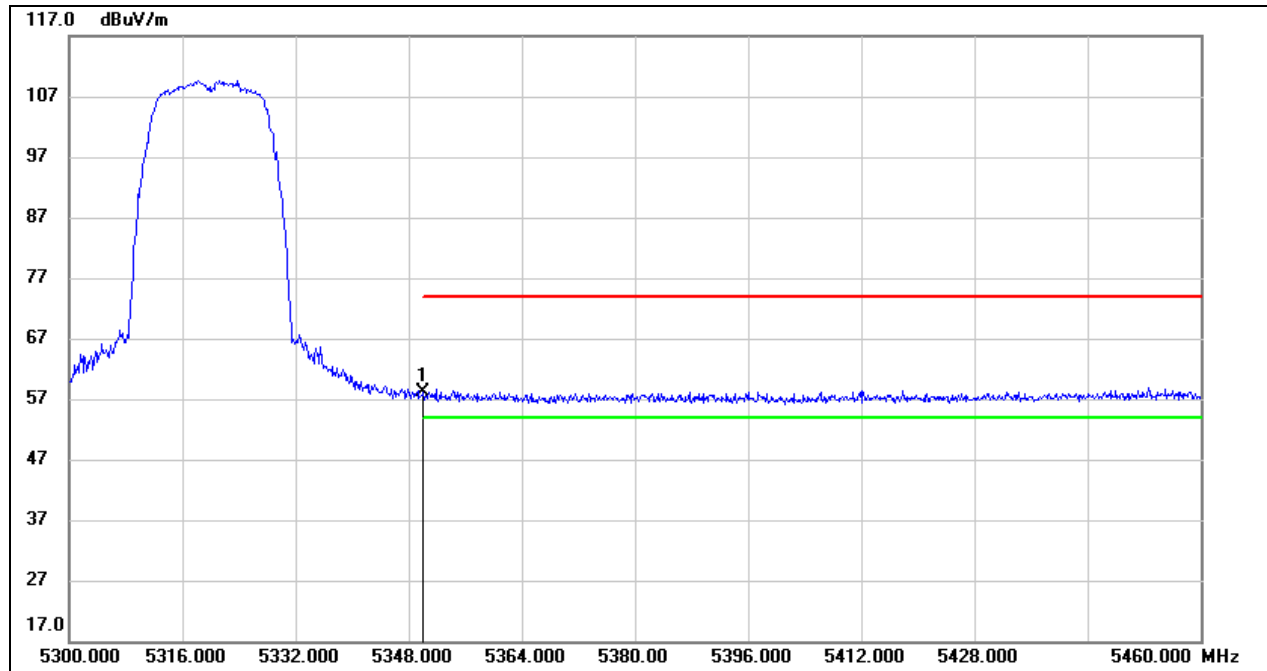

No.	Frequency (MHz)	Reading (dBuV)	Correct (dB/m)	Result (dBuV/m)	Limit (dBuV/m)	Margin (dB)	Remark
1	5350.000	17.00	41.20	58.20	74.00	-15.80	peak

- Note:
1. Measurement = Reading Level + Correct Factor.
 2. If Peak Result complies with AV limit, AV Result is deemed to comply with AV limit.
 3. Peak: Peak detector.
 4. Only the worst data was recorded, if it complies with the limit, the other emissions deemed to comply with the limit.



AVG

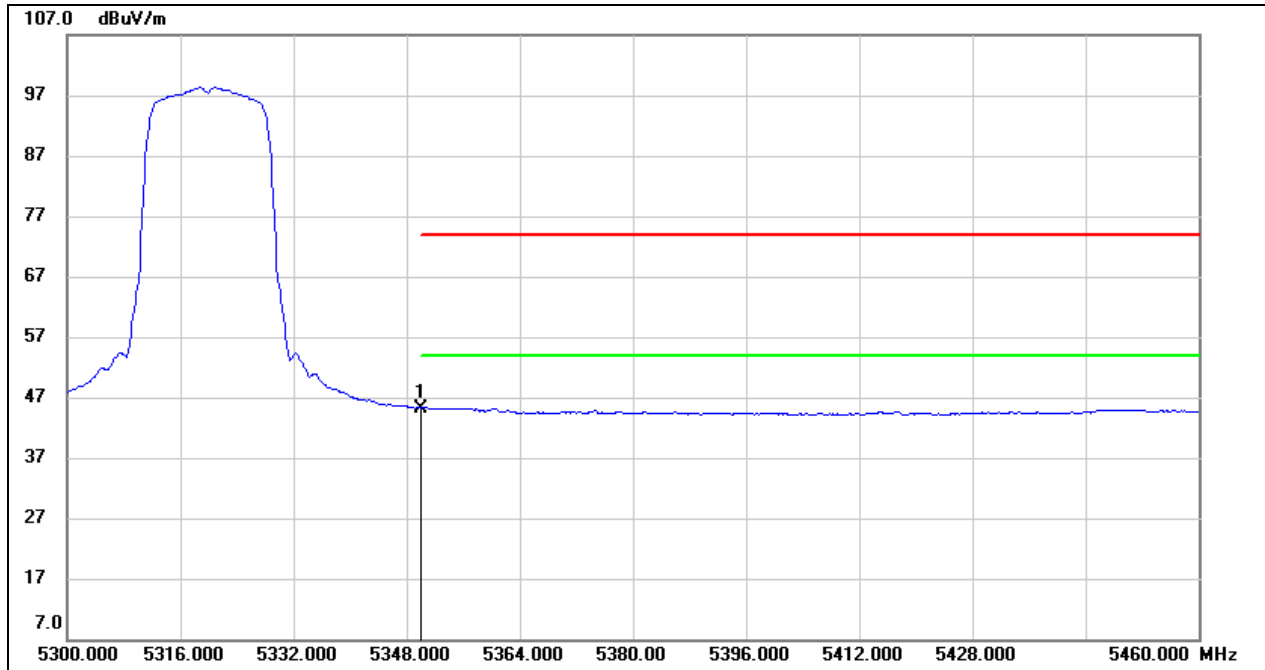

No.	Frequency (MHz)	Reading (dBuV)	Correct (dB/m)	Result (dBuV/m)	Limit (dBuV/m)	Margin (dB)	Remark
1	5350.000	4.04	41.20	45.24	54.00	-8.76	AVG

- Note:
1. Measurement = Reading Level + Correct Factor.
 2. If Peak Result complies with AV limit, AV Result is deemed to comply with AV limit.
 3. AVG: $VBW=1/Ton$, where: Ton is the transmitting duration.
 4. For the transmitting duration, please refer to clause 7.1.
 5. Only the worst data was recorded, if it complies with the limit, the other emissions deemed to comply with the limit.

Note: All the polarities (Vertical & Horizontal) had been tested, only the worst data was recorded in the report.



UNII-2C BAND

ANTENNA 1 TEST RESULTS (WORST CASE)

RESTRICTED BANDEDGE (LOW CHANNEL, HORIZONTAL)

PEAK

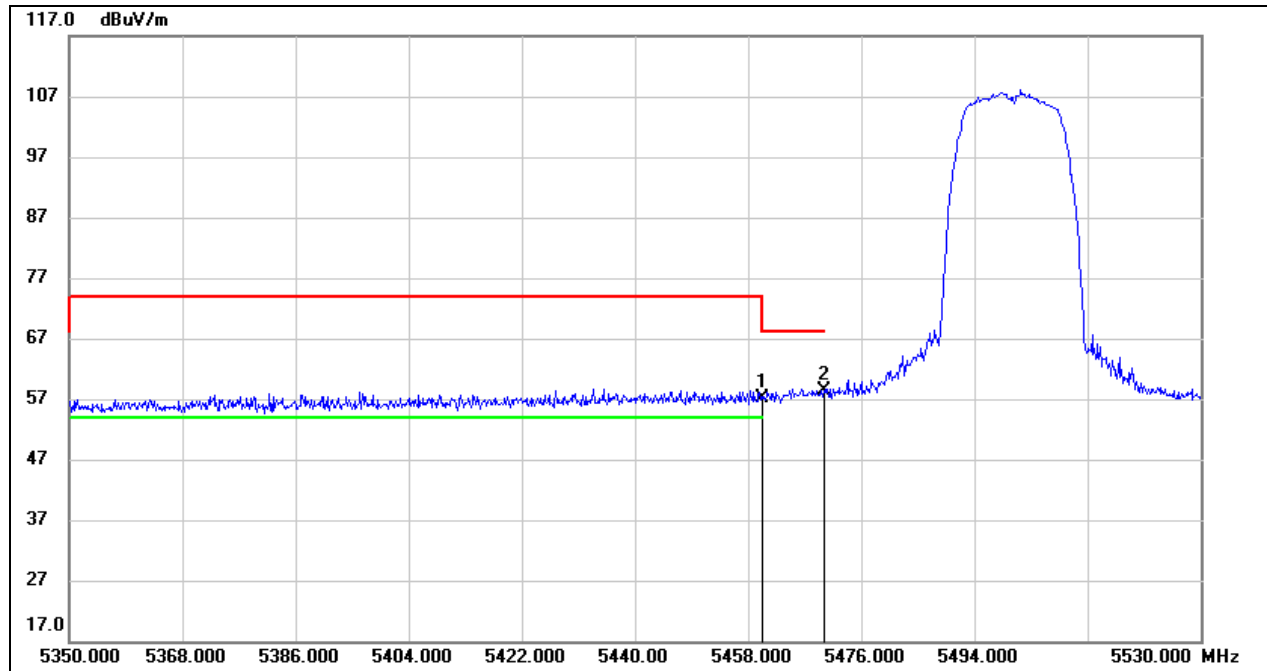

No.	Frequency (MHz)	Reading (dBuV)	Correct (dB/m)	Result (dBuV/m)	Limit (dBuV/m)	Margin (dB)	Remark
1	5460.000	15.35	41.82	57.17	68.20	-11.03	peak
2	5470.000	16.42	41.87	58.29	68.20	-9.91	peak

Note: 1. Measurement = Reading Level + Correct Factor.
 2. If Peak Result complies with AV limit, AV Result is deemed to comply with AV limit.
 3. Peak: Peak detector.
 4. Only the worst data was recorded, if it complies with the limit, the other emissions deemed to comply with the limit.



AVG

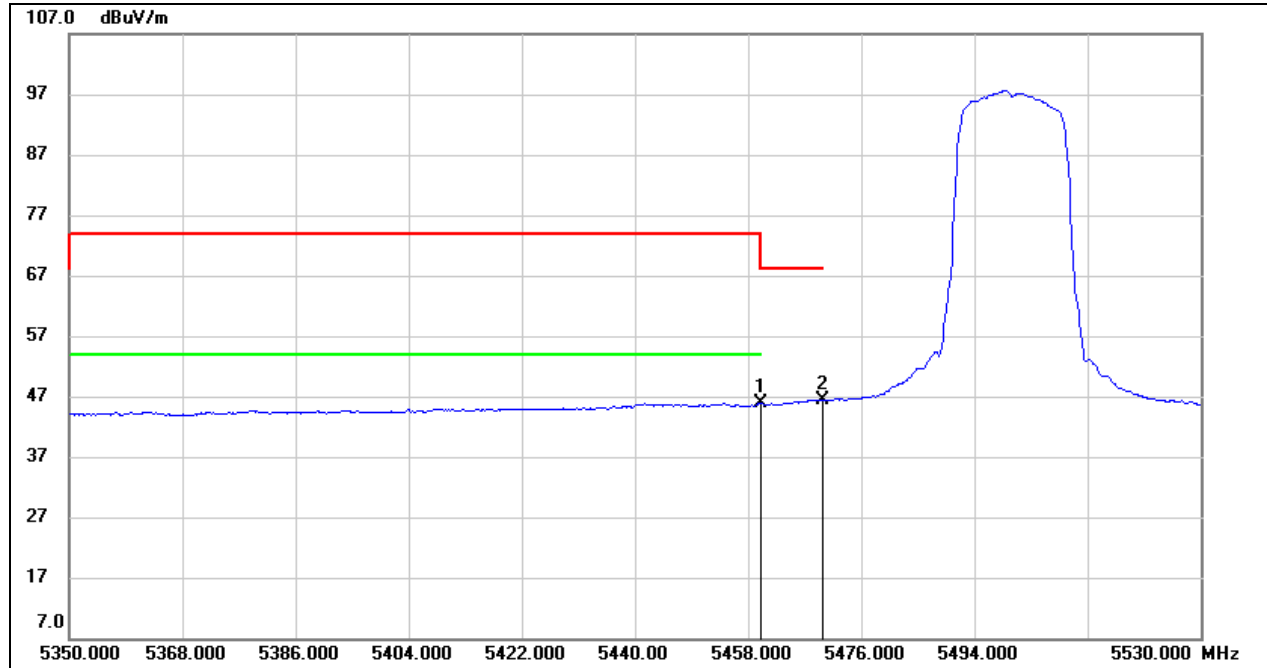

No.	Frequency (MHz)	Reading (dBuV)	Correct (dB/m)	Result (dBuV/m)	Limit (dBuV/m)	Margin (dB)	Remark
1	5460.000	4.01	41.82	45.83	54.00	-8.17	AVG
2	5470.000	4.60	41.87	46.47	/	/	AVG

- Note:
1. Measurement = Reading Level + Correct Factor.
 2. If Peak Result complies with AV limit, AV Result is deemed to comply with AV limit.
 3. AVG: $VBW=1/Ton$, where: Ton is the transmitting duration.
 4. For the transmitting duration, please refer to clause 7.1.
 5. Only the worst data was recorded, if it complies with the limit, the other emissions deemed to comply with the limit.



RESTRICTED BANDEDGE (HIGH CHANNEL, HORIZONTAL)

PEAK

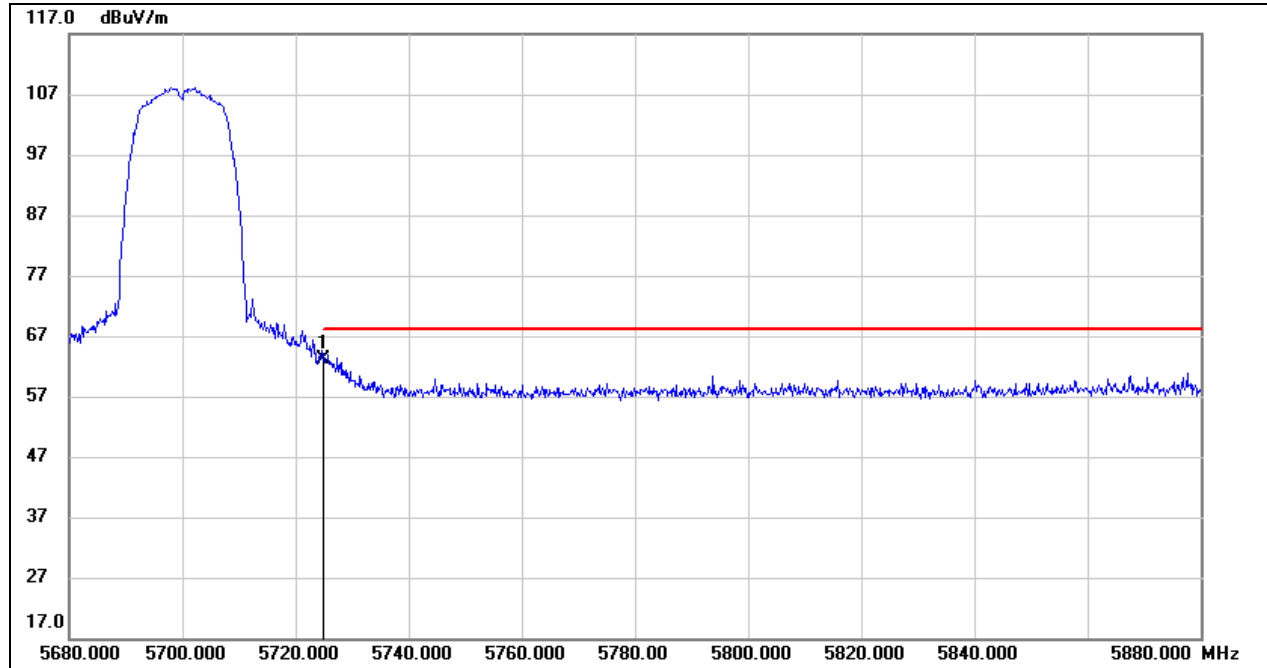

No.	Frequency (MHz)	Reading (dBuV)	Correct (dB/m)	Result (dBuV/m)	Limit (dBuV/m)	Margin (dB)	Remark
1	5725.000	21.45	41.67	63.12	68.20	-5.08	peak

- Note: 1. Measurement = Reading Level + Correct Factor.
 2. If Peak Result complies with AV limit, AV Result is deemed to comply with AV limit.
 3. Peak: Peak detector.
 4. Only the worst data was recorded, if it complies with the limit, the other emissions deemed to comply with the limit.

UNII-3 BAND

ANTENNA 1 TEST RESULTS (WORST CASE)

RESTRICTED BANDEDGE (LOW CHANNEL, HORIZONTAL)

PEAK

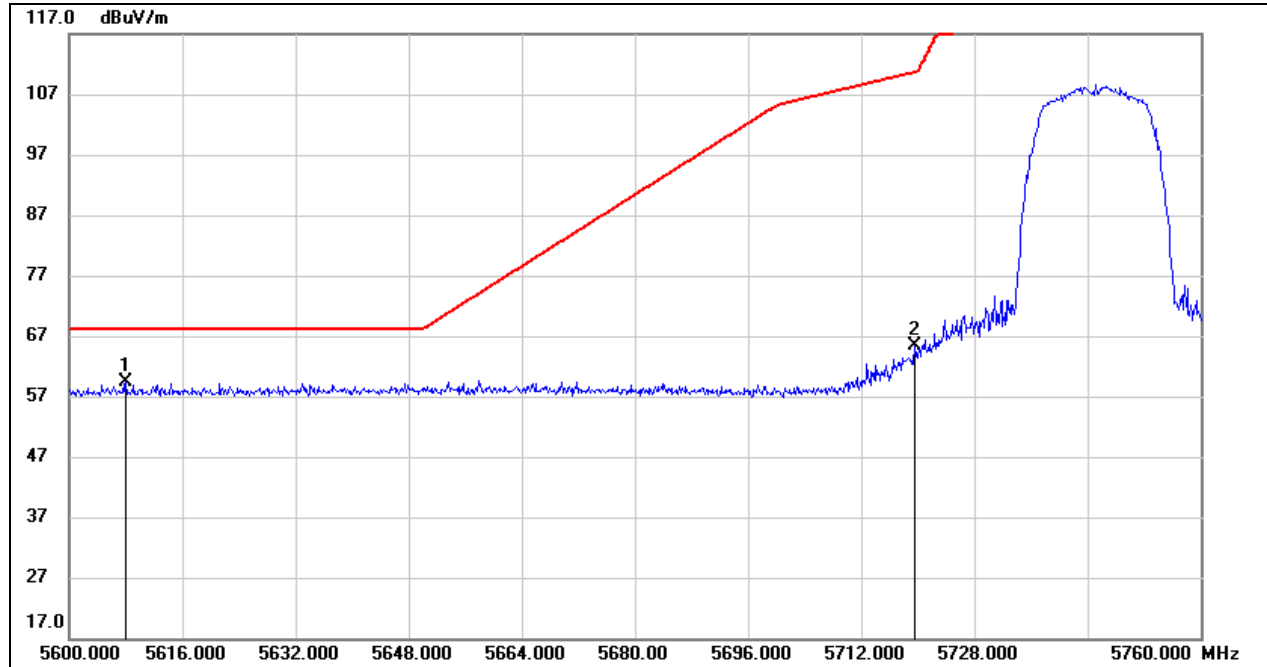

No.	Frequency (MHz)	Reading (dBuV)	Correct (dB/m)	Result (dBuV/m)	Limit (dBuV/m)	Margin (dB)	Remark
1	5608.000	17.55	41.72	59.27	68.20	-8.93	peak
2	5719.520	23.75	41.64	65.39	110.67	-45.28	peak

- Note: 1. Measurement = Reading Level + Correct Factor.
 2. If Peak Result complies with AV limit, AV Result is deemed to comply with AV limit.
 3. Peak: Peak detector.
 4. Only the worst data was recorded, if it complies with the limit, the other emissions deemed to comply with the limit.

RESTRICTED BANDEDGE (HIGH CHANNEL, HORIZONTAL)

PEAK

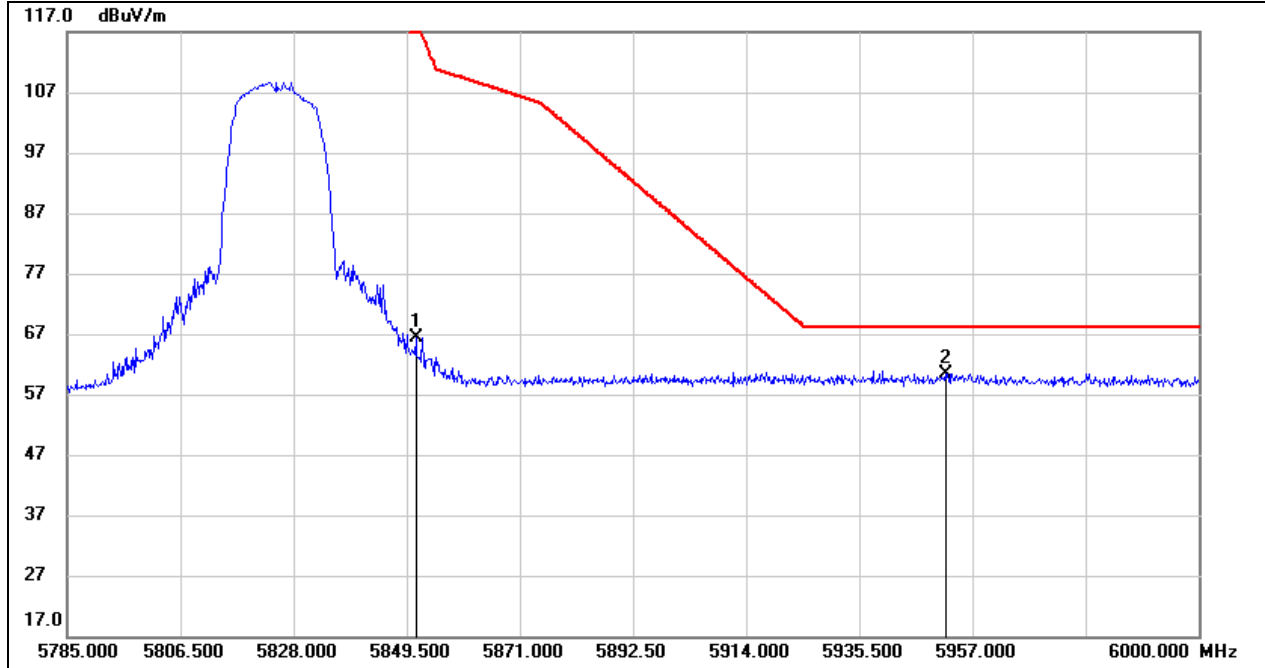

No.	Frequency (MHz)	Reading (dBuV)	Correct (dB/m)	Result (dBuV/m)	Limit (dBuV/m)	Margin (dB)	Remark
1	5851.220	23.92	42.54	66.46	119.42	-52.96	peak
2	5951.840	17.71	42.78	60.49	68.20	-7.71	peak

- Note: 1. Measurement = Reading Level + Correct Factor.
 2. If Peak Result complies with AV limit, AV Result is deemed to comply with AV limit.
 3. Peak: Peak detector.
 4. Only the worst data was recorded, if it complies with the limit, the other emissions deemed to comply with the limit.

Note: All the polarities (Vertical & Horizontal) and Antennas had been tested, only the worst data was recorded in the report.

8.1.1. 802.11ac VHT20 MIMO MODE

UNII-1 BAND

RESTRICTED BANDEDGE (LOW CHANNEL, HORIZONTAL)

PEAK

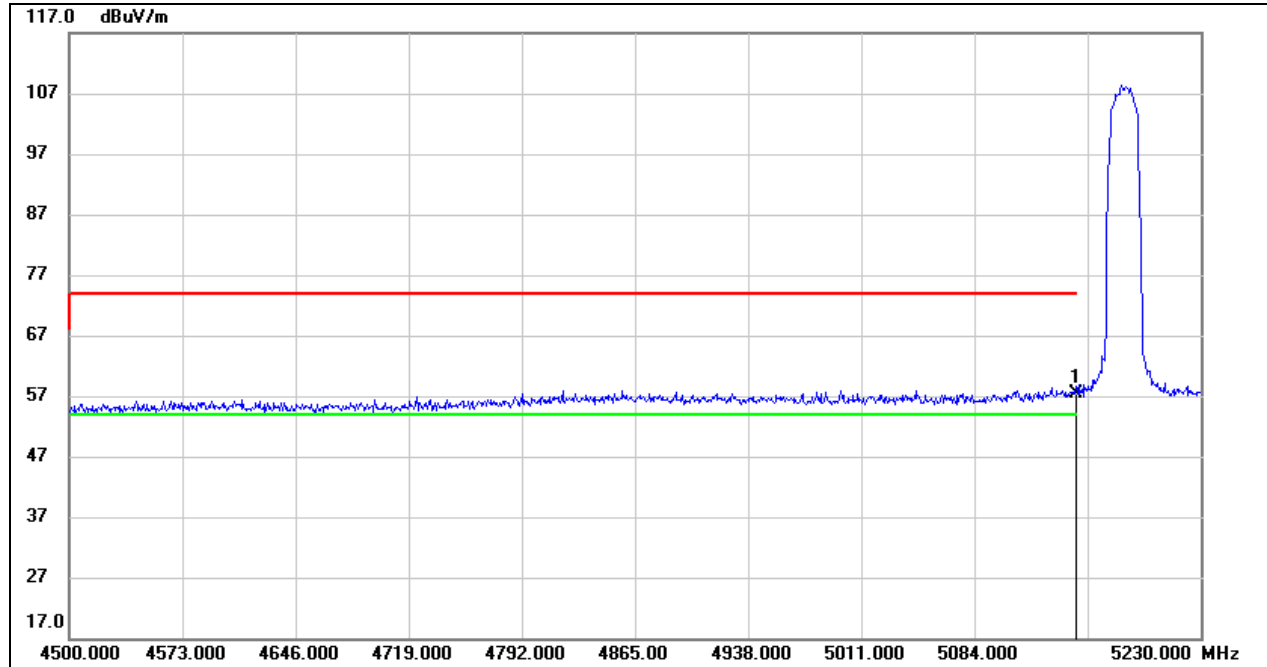

No.	Frequency (MHz)	Reading (dBuV)	Correct (dB/m)	Result (dBuV/m)	Limit (dBuV/m)	Margin (dB)	Remark
1	5150.000	16.25	41.19	57.44	74.00	-16.56	peak

- Note:
1. Measurement = Reading Level + Correct Factor.
 2. If Peak Result complies with AV limit, AV Result is deemed to comply with AV limit.
 3. Peak: Peak detector.
 4. Only the worst data was recorded, if it complies with the limit, the other emissions deemed to comply with the limit.



AVG

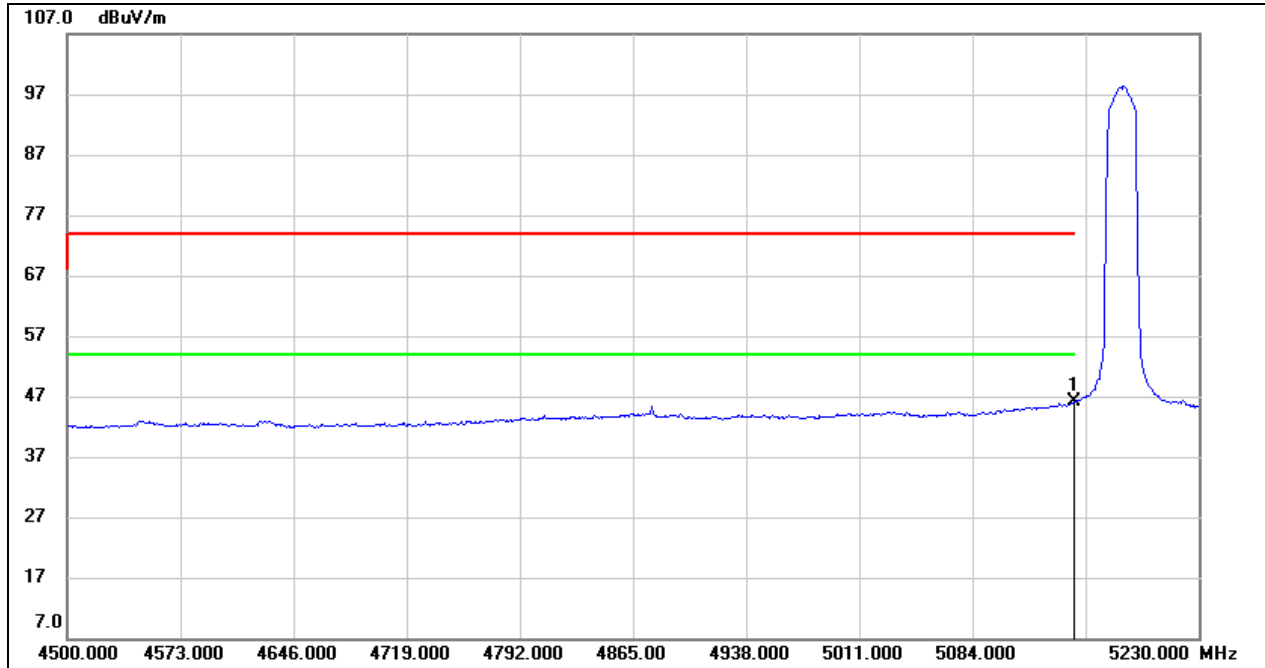

No.	Frequency (MHz)	Reading (dBuV)	Correct (dB/m)	Result (dBuV/m)	Limit (dBuV/m)	Margin (dB)	Remark
1	5150.000	4.88	41.19	46.07	54.00	-7.93	AVG

- Note: 1. Measurement = Reading Level + Correct Factor.
 2. If Peak Result complies with AV limit, AV Result is deemed to comply with AV limit.
 3. AVG: $VBW=1/Ton$, where: Ton is the transmitting duration.
 4. For the transmitting duration, please refer to clause 7.1.
 5. Only the worst data was recorded, if it complies with the limit, the other emissions deemed to comply with the limit.



UNII-2A BAND

RESTRICTED BANDEDGE (HIGH CHANNEL, HORIZONTAL)

PEAK

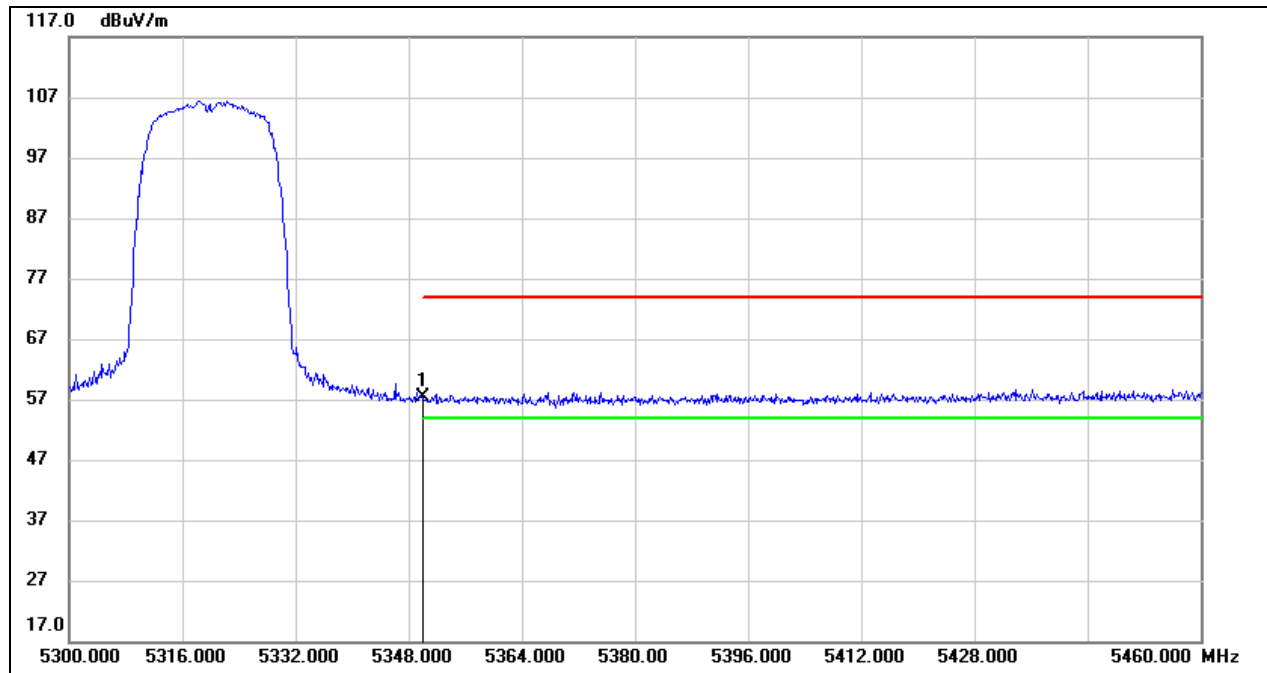

No.	Frequency (MHz)	Reading (dBuV)	Correct (dB/m)	Result (dBuV/m)	Limit (dBuV/m)	Margin (dB)	Remark
1	5350.000	16.20	41.20	57.40	74.00	-16.60	peak

- Note:
1. Measurement = Reading Level + Correct Factor.
 2. If Peak Result complies with AV limit, AV Result is deemed to comply with AV limit.
 3. Peak: Peak detector.
 4. Only the worst data was recorded, if it complies with the limit, the other emissions deemed to comply with the limit.



AVG

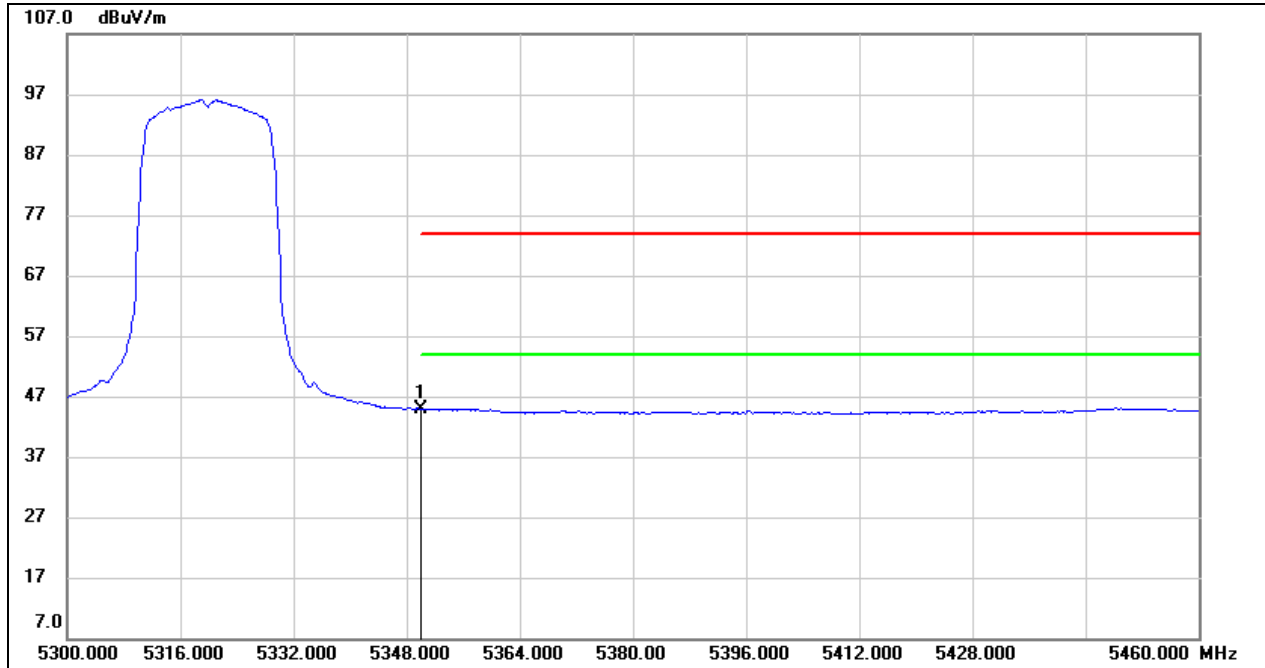

No.	Frequency (MHz)	Reading (dBuV)	Correct (dB/m)	Result (dBuV/m)	Limit (dBuV/m)	Margin (dB)	Remark
1	5350.000	3.62	41.20	44.82	54.00	-9.18	AVG

- Note:
1. Measurement = Reading Level + Correct Factor.
 2. If Peak Result complies with AV limit, AV Result is deemed to comply with AV limit.
 3. AVG: VBW=1/Ton, where: Ton is the transmitting duration.
 4. For the transmitting duration, please refer to clause 7.1.
 5. Only the worst data was recorded, if it complies with the limit, the other emissions deemed to comply with the limit.

UNII-2C BAND

RESTRICTED BANDEDGE (LOW CHANNEL, HORIZONTAL)

PEAK

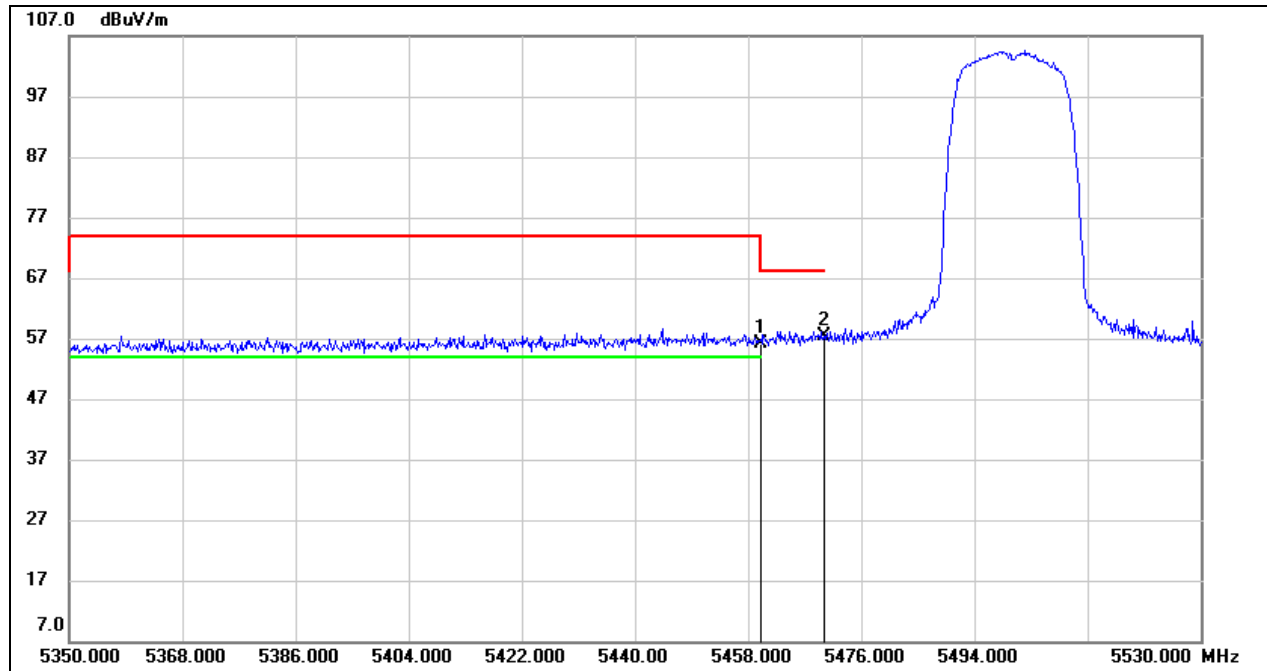

No.	Frequency (MHz)	Reading (dBuV)	Correct (dB/m)	Result (dBuV/m)	Limit (dBuV/m)	Margin (dB)	Remark
1	5460.000	14.39	41.82	56.21	68.20	-11.99	peak
2	5470.000	15.62	41.87	57.49	68.20	-10.71	peak

Note: 1. Measurement = Reading Level + Correct Factor.
 2. If Peak Result complies with AV limit, AV Result is deemed to comply with AV limit.
 3. Peak: Peak detector.
 4. Only the worst data was recorded, if it complies with the limit, the other emissions deemed to comply with the limit.



AVG

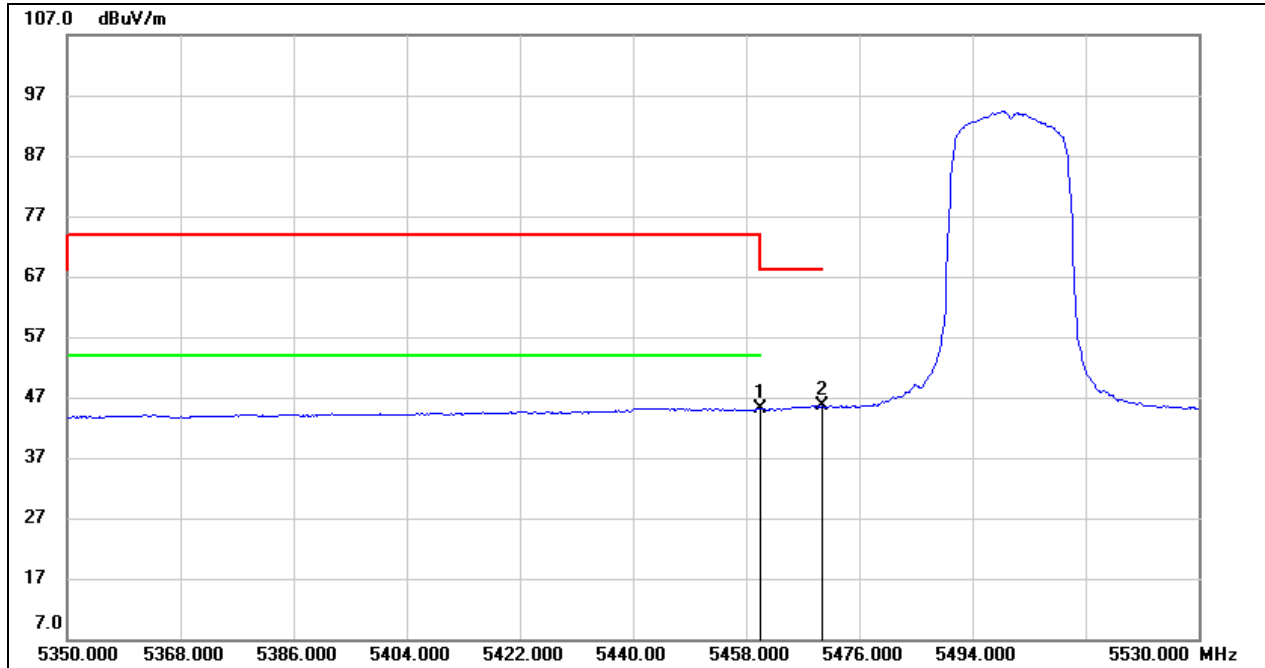

No.	Frequency (MHz)	Reading (dBuV)	Correct (dB/m)	Result (dBuV/m)	Limit (dBuV/m)	Margin (dB)	Remark
1	5460.000	3.31	41.82	45.13	54.00	-8.87	AVG
2	5470.000	3.66	41.87	45.53	/	/	AVG

- Note: 1. Measurement = Reading Level + Correct Factor.
 2. If Peak Result complies with AV limit, AV Result is deemed to comply with AV limit.
 3. AVG: $VBW=1/Ton$, where: Ton is the transmitting duration.
 4. For the transmitting duration, please refer to clause 7.1.
 5. Only the worst data was recorded, if it complies with the limit, the other emissions deemed to comply with the limit.



RESTRICTED BANDEDGE (HIGH CHANNEL, HORIZONTAL)

PEAK

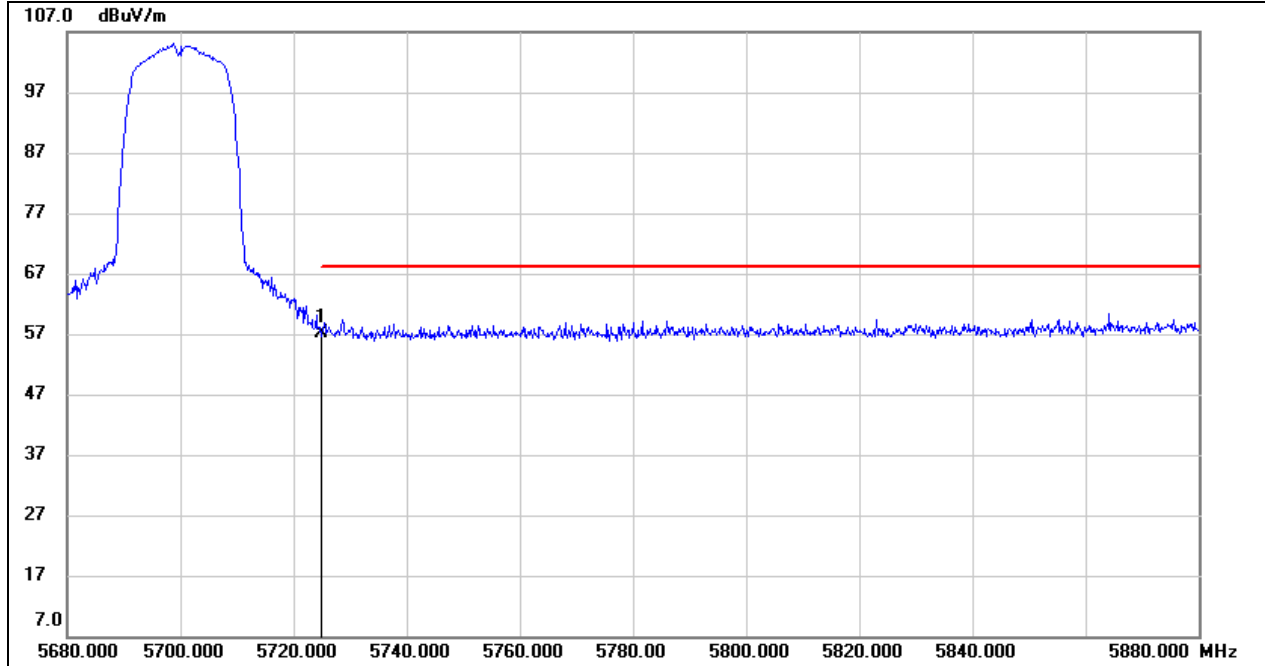

No.	Frequency (MHz)	Reading (dBuV)	Correct (dB/m)	Result (dBuV/m)	Limit (dBuV/m)	Margin (dB)	Remark
1	5725.000	15.55	41.67	57.22	68.20	-10.98	peak

- Note: 1. Measurement = Reading Level + Correct Factor.
 2. If Peak Result complies with AV limit, AV Result is deemed to comply with AV limit.
 3. Peak: Peak detector.
 4. Only the worst data was recorded, if it complies with the limit, the other emissions deemed to comply with the limit.

UNII-3 BAND

RESTRICTED BANDEDGE (LOW CHANNEL, HORIZONTAL)

PEAK

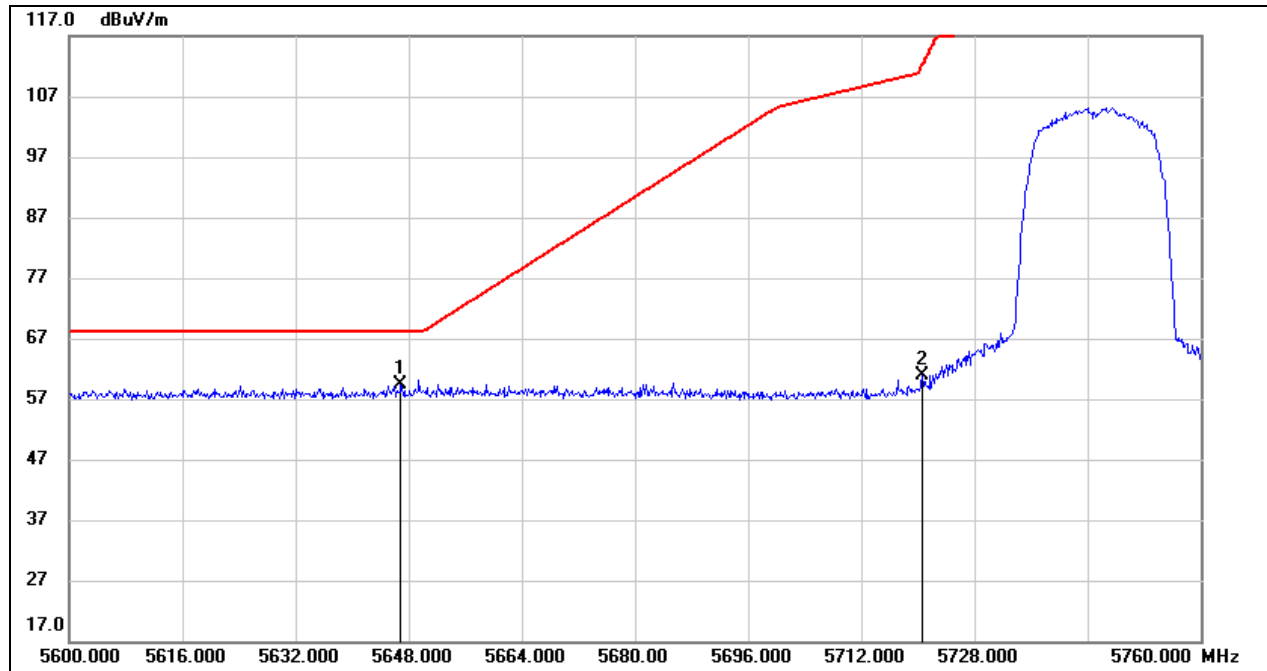

No.	Frequency (MHz)	Reading (dBuV)	Correct (dB/m)	Result (dBuV/m)	Limit (dBuV/m)	Margin (dB)	Remark
1	5646.880	17.82	41.65	59.47	68.20	-8.73	peak
2	5720.640	19.33	41.64	60.97	112.26	-51.29	peak

Note: 1. Measurement = Reading Level + Correct Factor.
 2. If Peak Result complies with AV limit, AV Result is deemed to comply with AV limit.
 3. Peak: Peak detector.
 4. Only the worst data was recorded, if it complies with the limit, the other emissions deemed to comply with the limit.

RESTRICTED BANDEDGE (HIGH CHANNEL, HORIZONTAL)

PEAK

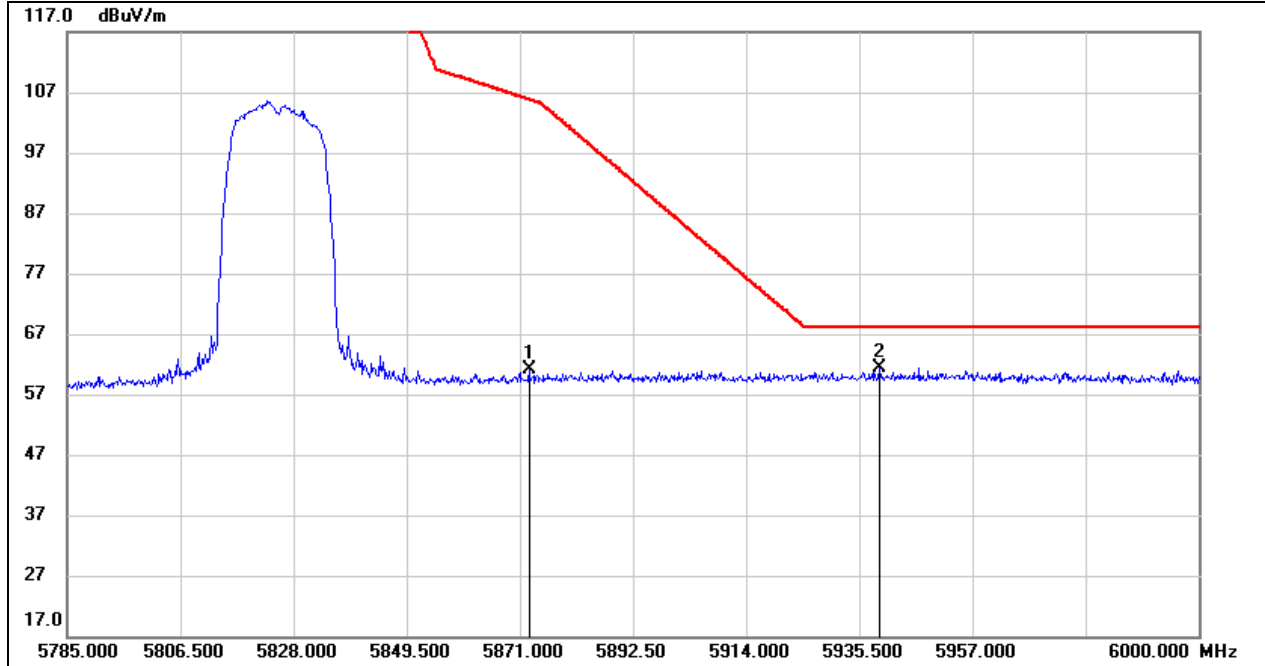

No.	Frequency (MHz)	Reading (dBuV)	Correct (dB/m)	Result (dBuV/m)	Limit (dBuV/m)	Margin (dB)	Remark
1	5872.720	18.34	42.76	61.10	105.84	-44.74	peak
2	5939.370	18.43	42.85	61.28	68.20	-6.92	peak

- Note: 1. Measurement = Reading Level + Correct Factor.
 2. If Peak Result complies with AV limit, AV Result is deemed to comply with AV limit.
 3. Peak: Peak detector.
 4. Only the worst data was recorded, if it complies with the limit, the other emissions deemed to comply with the limit.

Note: All the polarities (Vertical & Horizontal) had been tested, only the worst data was recorded in the report.

8.1.2. 802.11ac VHT40 MIMO MODE

UNII-1 BAND

RESTRICTED BANDEDGE (LOW CHANNEL, HORIZONTAL)

PEAK

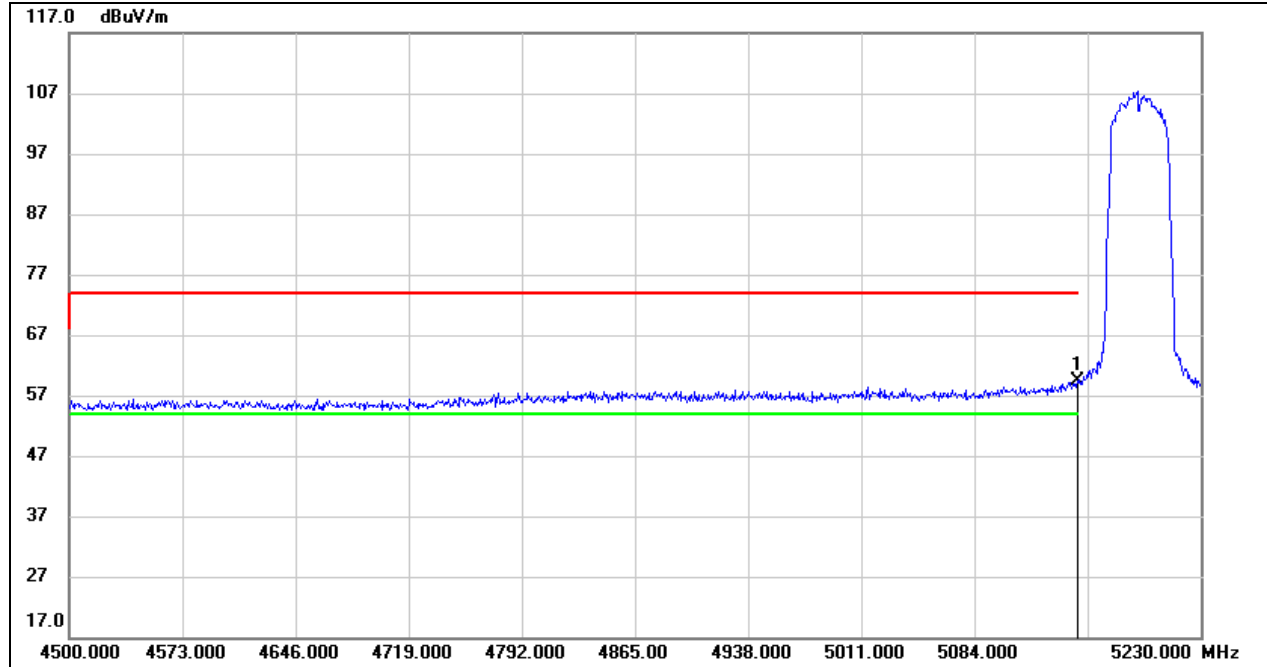

No.	Frequency (MHz)	Reading (dBuV)	Correct (dB/m)	Result (dBuV/m)	Limit (dBuV/m)	Margin (dB)	Remark
1	5150.000	18.08	41.19	59.27	74.00	-14.73	peak

- Note: 1. Measurement = Reading Level + Correct Factor.
 2. If Peak Result complies with AV limit, AV Result is deemed to comply with AV limit.
 3. Peak: Peak detector.
 4. Only the worst data was recorded, if it complies with the limit, the other emissions deemed to comply with the limit.



AVG

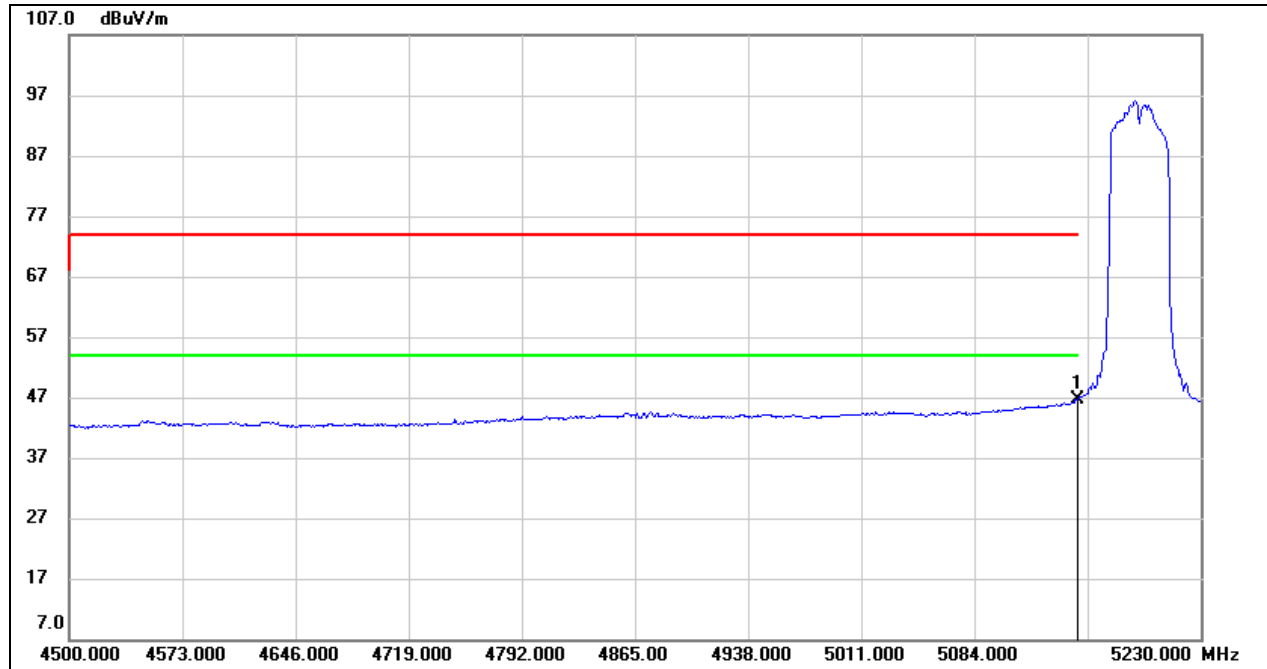

No.	Frequency (MHz)	Reading (dBuV)	Correct (dB/m)	Result (dBuV/m)	Limit (dBuV/m)	Margin (dB)	Remark
1	5150.000	5.55	41.19	46.74	54.00	-7.26	AVG

- Note:
1. Measurement = Reading Level + Correct Factor.
 2. If Peak Result complies with AV limit, AV Result is deemed to comply with AV limit.
 3. AVG: $VBW=1/Ton$, where: Ton is the transmitting duration.
 4. For the transmitting duration, please refer to clause 7.1.
 5. Only the worst data was recorded, if it complies with the limit, the other emissions deemed to comply with the limit.

UNII-2A BAND

RESTRICTED BANDEDGE (HIGH CHANNEL, HORIZONTAL)

PEAK

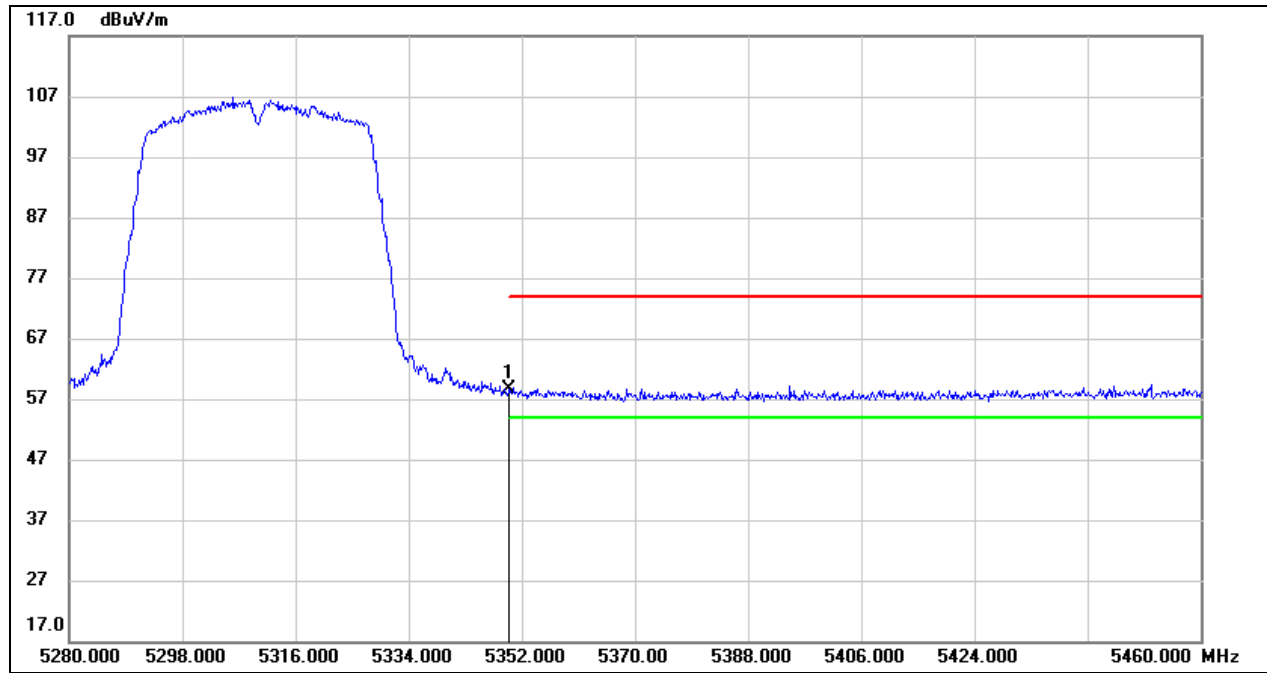

No.	Frequency (MHz)	Reading (dBuV)	Correct (dB/m)	Result (dBuV/m)	Limit (dBuV/m)	Margin (dB)	Remark
1	5350.000	17.40	41.20	58.60	74.00	-15.40	peak

- Note: 1. Measurement = Reading Level + Correct Factor.
 2. If Peak Result complies with AV limit, AV Result is deemed to comply with AV limit.
 3. Peak: Peak detector.
 4. Only the worst data was recorded, if it complies with the limit, the other emissions deemed to comply with the limit.



AVG

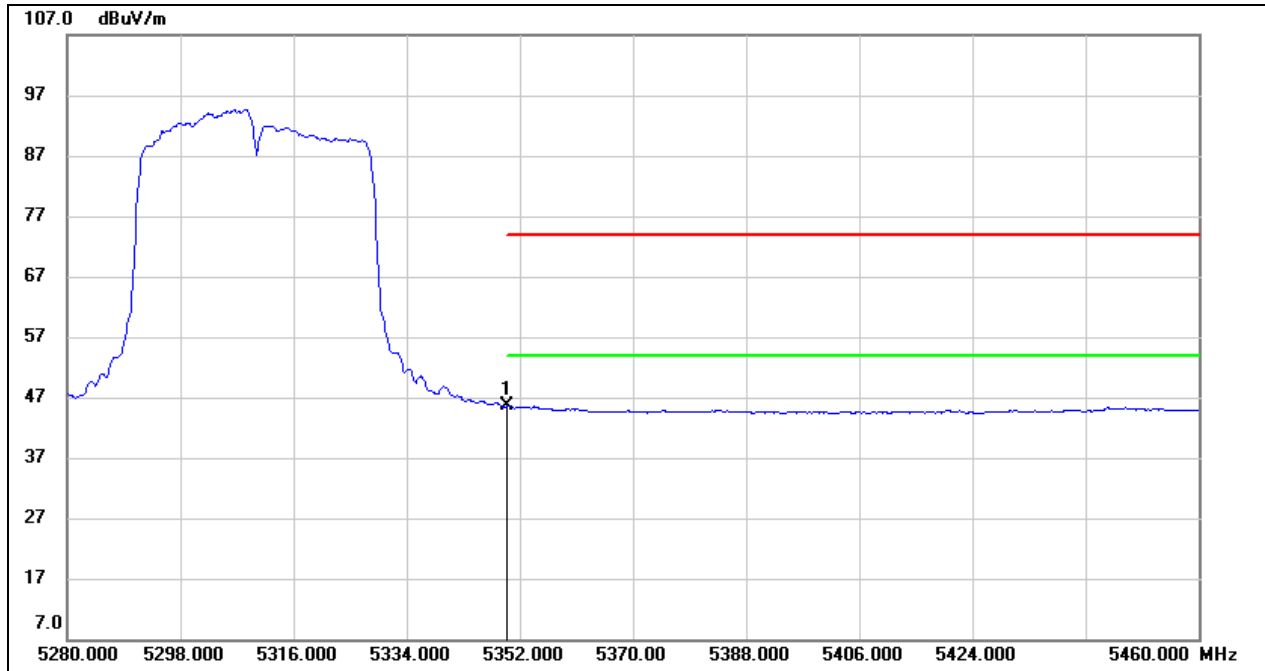

No.	Frequency (MHz)	Reading (dBuV)	Correct (dB/m)	Result (dBuV/m)	Limit (dBuV/m)	Margin (dB)	Remark
1	5350.000	4.34	41.20	45.54	54.00	-8.46	AVG

- Note:
1. Measurement = Reading Level + Correct Factor.
 2. If Peak Result complies with AV limit, AV Result is deemed to comply with AV limit.
 3. AVG: $VBW=1/Ton$, where: Ton is the transmitting duration.
 4. For the transmitting duration, please refer to clause 7.1.
 5. Only the worst data was recorded, if it complies with the limit, the other emissions deemed to comply with the limit.



UNII-2C BAND

RESTRICTED BANDEDGE (LOW CHANNEL, HORIZONTAL)

PEAK

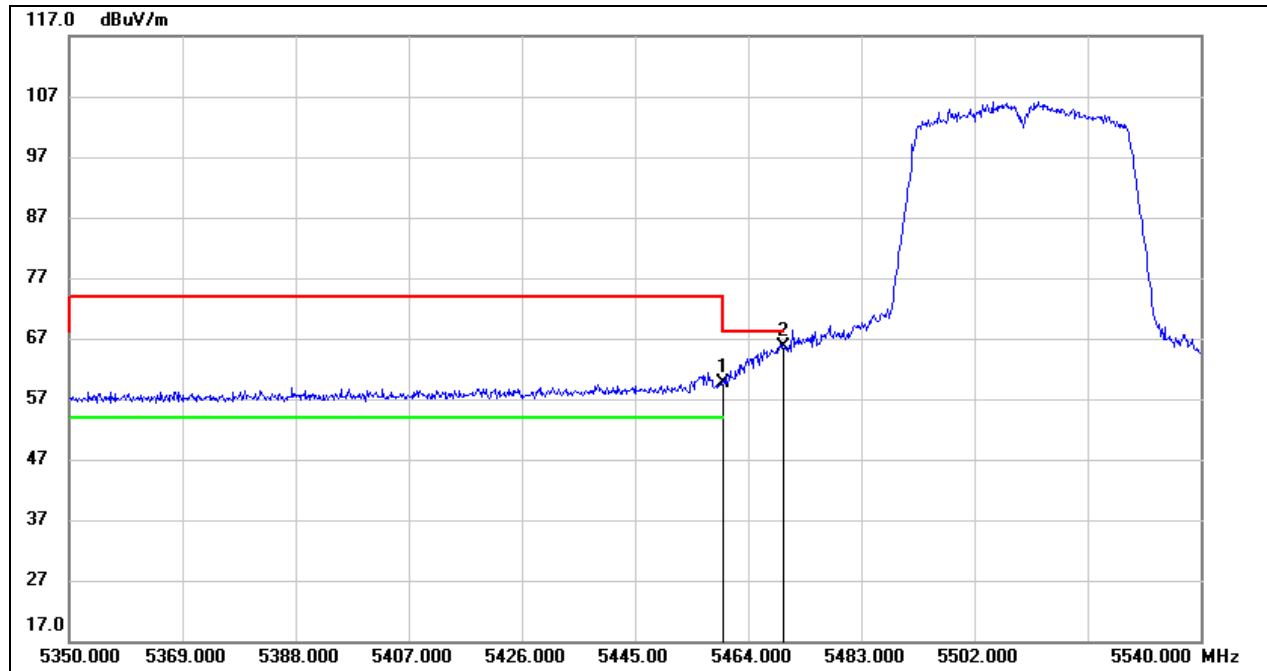

No.	Frequency (MHz)	Reading (dBuV)	Correct (dB/m)	Result (dBuV/m)	Limit (dBuV/m)	Margin (dB)	Remark
1	5460.000	17.79	41.82	59.61	68.20	-8.59	peak
2	5470.000	23.83	41.87	65.70	68.20	-2.50	peak

Note: 1. Measurement = Reading Level + Correct Factor.
 2. If Peak Result complies with AV limit, AV Result is deemed to comply with AV limit.
 3. Peak: Peak detector.
 4. Only the worst data was recorded, if it complies with the limit, the other emissions deemed to comply with the limit.



AVG

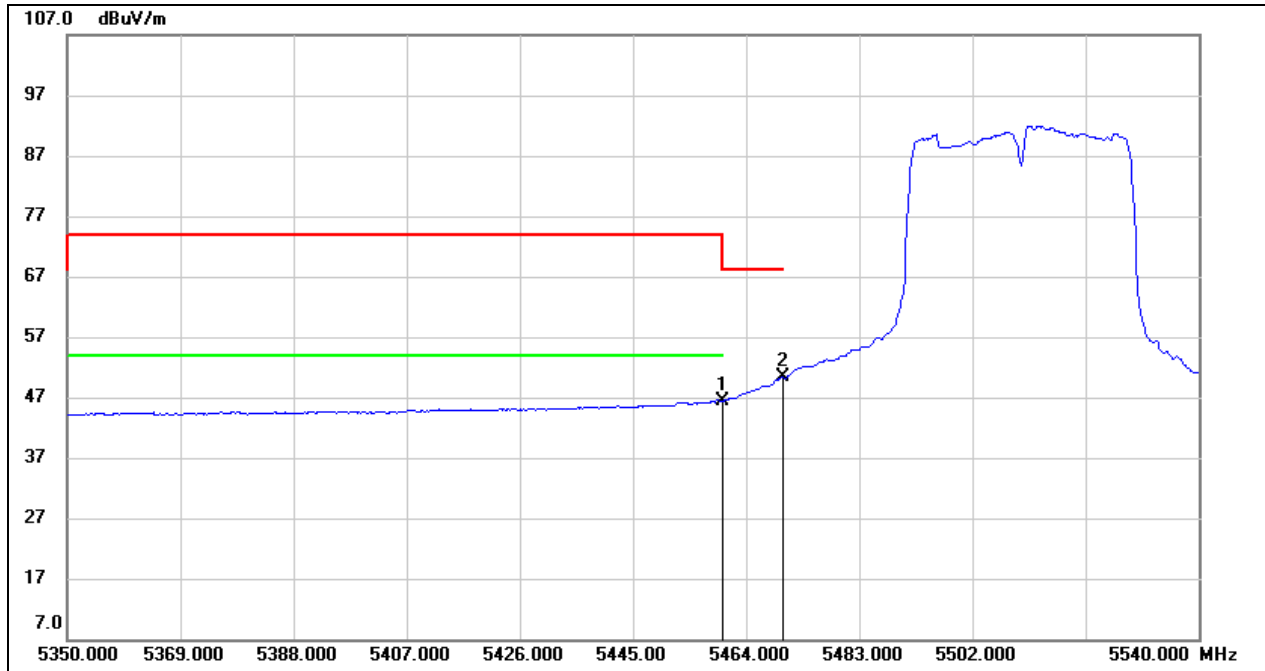

No.	Frequency (MHz)	Reading (dBuV)	Correct (dB/m)	Result (dBuV/m)	Limit (dBuV/m)	Margin (dB)	Remark
1	5460.000	4.60	41.82	46.42	54.00	-7.58	AVG
2	5470.000	8.47	41.87	50.34	/	/	AVG

- Note:
1. Measurement = Reading Level + Correct Factor.
 2. If Peak Result complies with AV limit, AV Result is deemed to comply with AV limit.
 3. AVG: $VBW=1/Ton$, where: Ton is the transmitting duration.
 4. For the transmitting duration, please refer to clause 7.1.
 5. Only the worst data was recorded, if it complies with the limit, the other emissions deemed to comply with the limit.

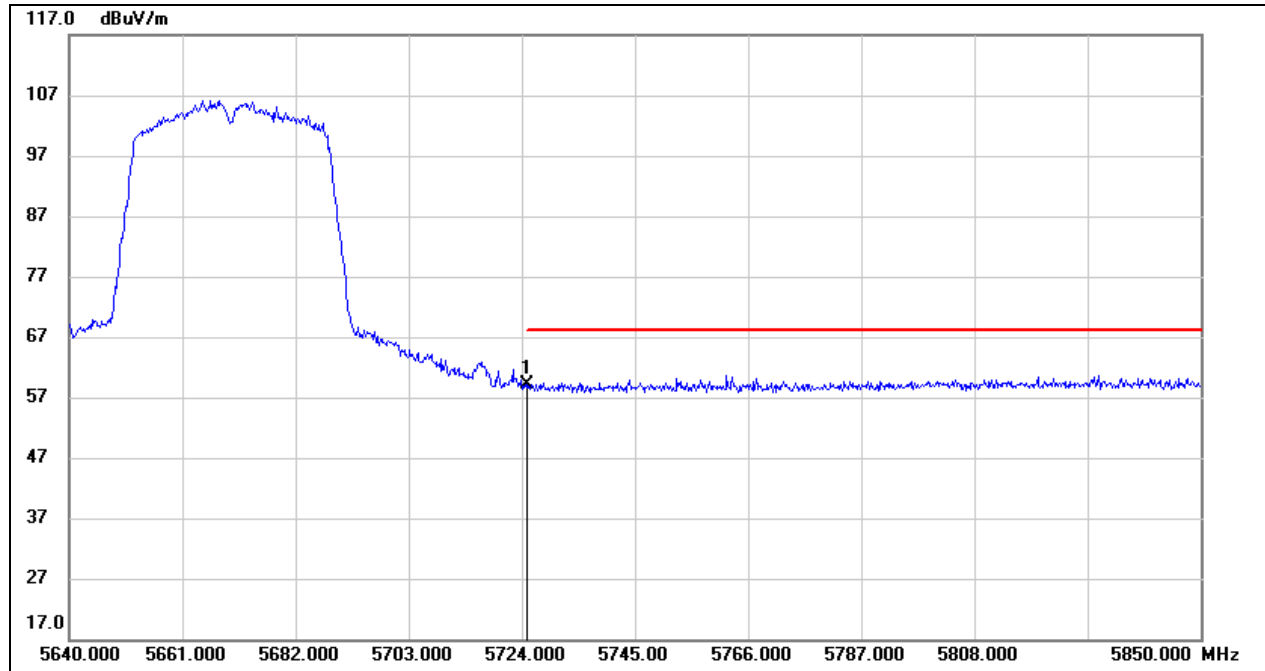
**RESTRICTED BANDEDGE (HIGH CHANNEL, HORIZONTAL)****PEAK**

No.	Frequency (MHz)	Reading (dBuV)	Correct (dB/m)	Result (dBuV/m)	Limit (dBuV/m)	Margin (dB)	Remark
1	5725.000	17.37	41.67	59.04	68.20	-9.16	peak

- Note: 1. Measurement = Reading Level + Correct Factor.
 2. If Peak Result complies with AV limit, AV Result is deemed to comply with AV limit.
 3. Peak: Peak detector.
 4. Only the worst data was recorded, if it complies with the limit, the other emissions deemed to comply with the limit.



UNII-3 BAND

RESTRICTED BANDEDGE (LOW CHANNEL, HORIZONTAL)

PEAK

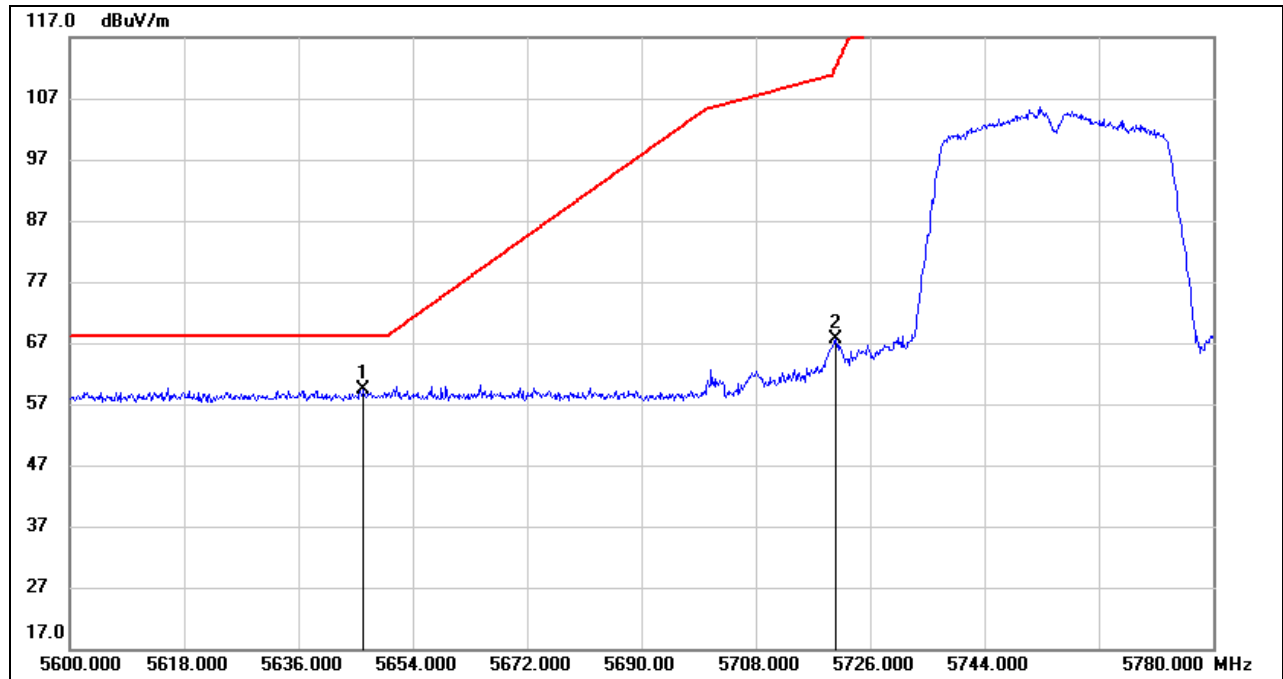

No.	Frequency (MHz)	Reading (dBuV)	Correct (dB/m)	Result (dBuV/m)	Limit (dBuV/m)	Margin (dB)	Remark
1	5646.260	17.78	41.65	59.43	68.20	-8.77	peak
2	5720.600	25.95	41.64	67.59	112.17	-44.58	peak

- Note: 1. Measurement = Reading Level + Correct Factor.
 2. If Peak Result complies with AV limit, AV Result is deemed to comply with AV limit.
 3. Peak: Peak detector.
 4. Only the worst data was recorded, if it complies with the limit, the other emissions deemed to comply with the limit.

RESTRICTED BANDEDGE (HIGH CHANNEL, HORIZONTAL)

PEAK

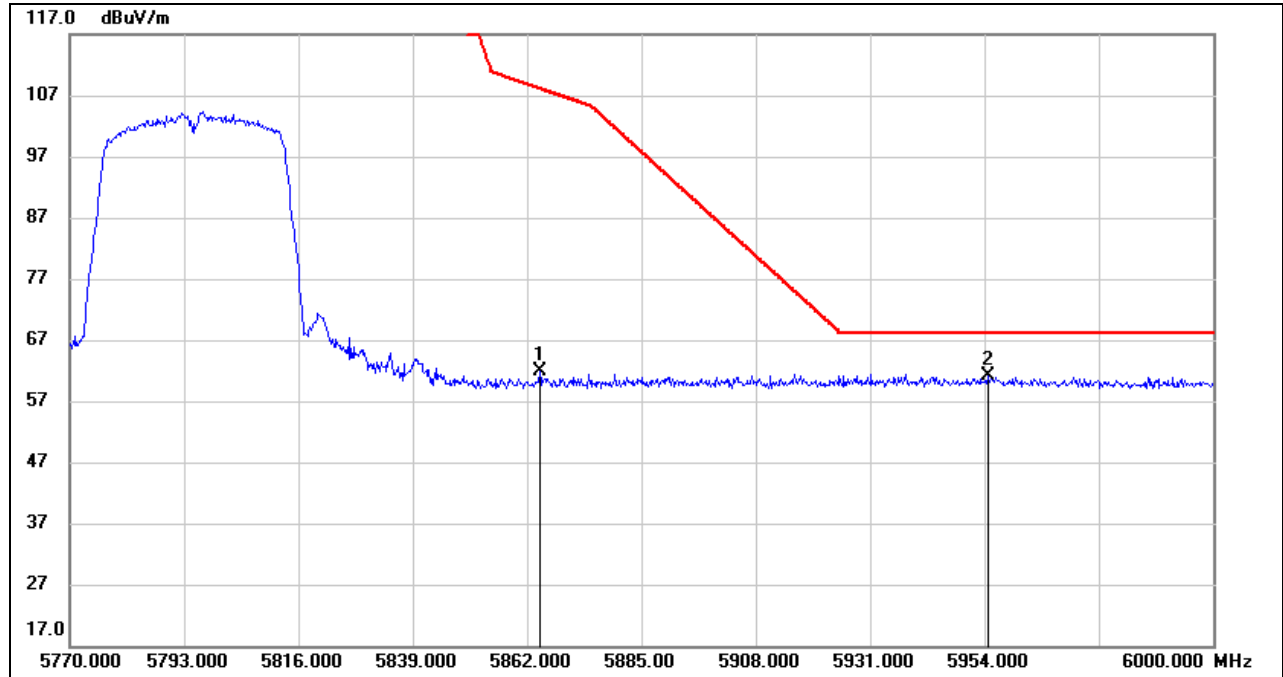

No.	Frequency (MHz)	Reading (dBuV)	Correct (dB/m)	Result (dBuV/m)	Limit (dBuV/m)	Margin (dB)	Remark
1	5864.530	19.11	42.67	61.78	108.13	-46.35	peak
2	5954.690	18.33	42.78	61.11	68.20	-7.09	peak

- Note: 1. Measurement = Reading Level + Correct Factor.
 2. If Peak Result complies with AV limit, AV Result is deemed to comply with AV limit.
 3. Peak: Peak detector.
 4. Only the worst data was recorded, if it complies with the limit, the other emissions deemed to comply with the limit.

Note: All the polarities (Vertical & Horizontal) had been tested, only the worst data was recorded in the report.



8.1.3. 802.11ac VHT80 MIMO MODE

UNII-1 BAND

RESTRICTED BANDEDGE (LOW CHANNEL, HORIZONTAL)

PEAK

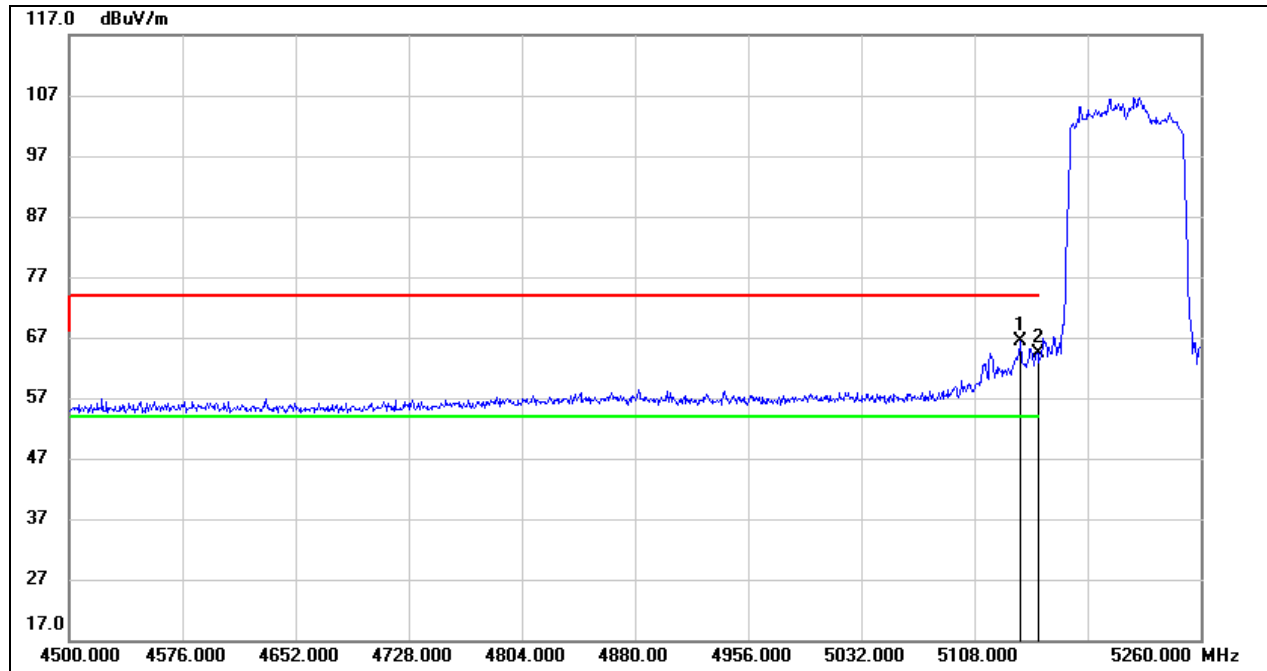

No.	Frequency (MHz)	Reading (dBuV)	Correct (dB/m)	Result (dBuV/m)	Limit (dBuV/m)	Margin (dB)	Remark
1	5139.160	25.27	41.09	66.36	74.00	-7.64	peak
2	5150.000	23.22	41.19	64.41	74.00	-9.59	peak

Note: 1. Measurement = Reading Level + Correct Factor.
 2. If Peak Result complies with AV limit, AV Result is deemed to comply with AV limit.
 3. Peak: Peak detector.
 4. Only the worst data was recorded, if it complies with the limit, the other emissions deemed to comply with the limit.

AVG

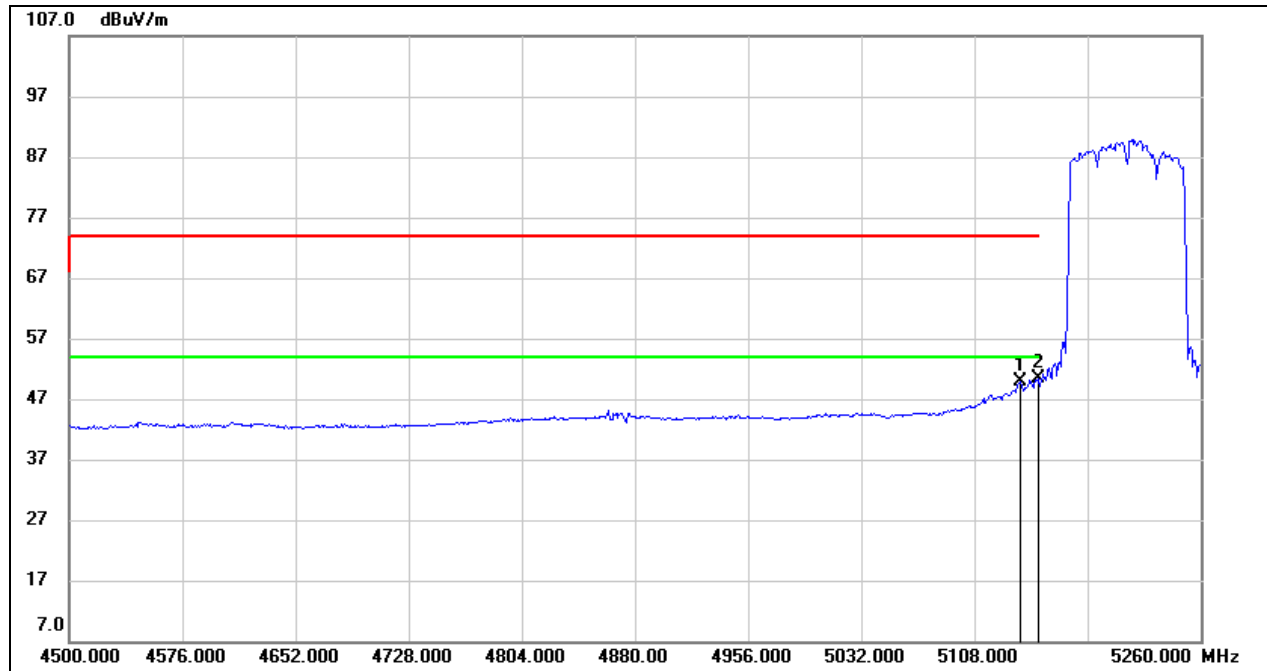

No.	Frequency (MHz)	Reading (dBuV)	Correct (dB/m)	Result (dBuV/m)	Limit (dBuV/m)	Margin (dB)	Remark
1	5139.160	8.80	41.09	49.89	54.00	-4.11	AVG
2	5150.000	9.09	41.19	50.28	54.00	-3.72	AVG

- Note:
1. Measurement = Reading Level + Correct Factor.
 2. If Peak Result complies with AV limit, AV Result is deemed to comply with AV limit.
 3. AVG: $VBW=1/Ton$, where: Ton is the transmitting duration.
 4. For the transmitting duration, please refer to clause 7.1.
 5. Only the worst data was recorded, if it complies with the limit, the other emissions deemed to comply with the limit.

UNII-2A BAND

RESTRICTED BANDEDGE (LOW CHANNEL, HORIZONTAL)

PEAK

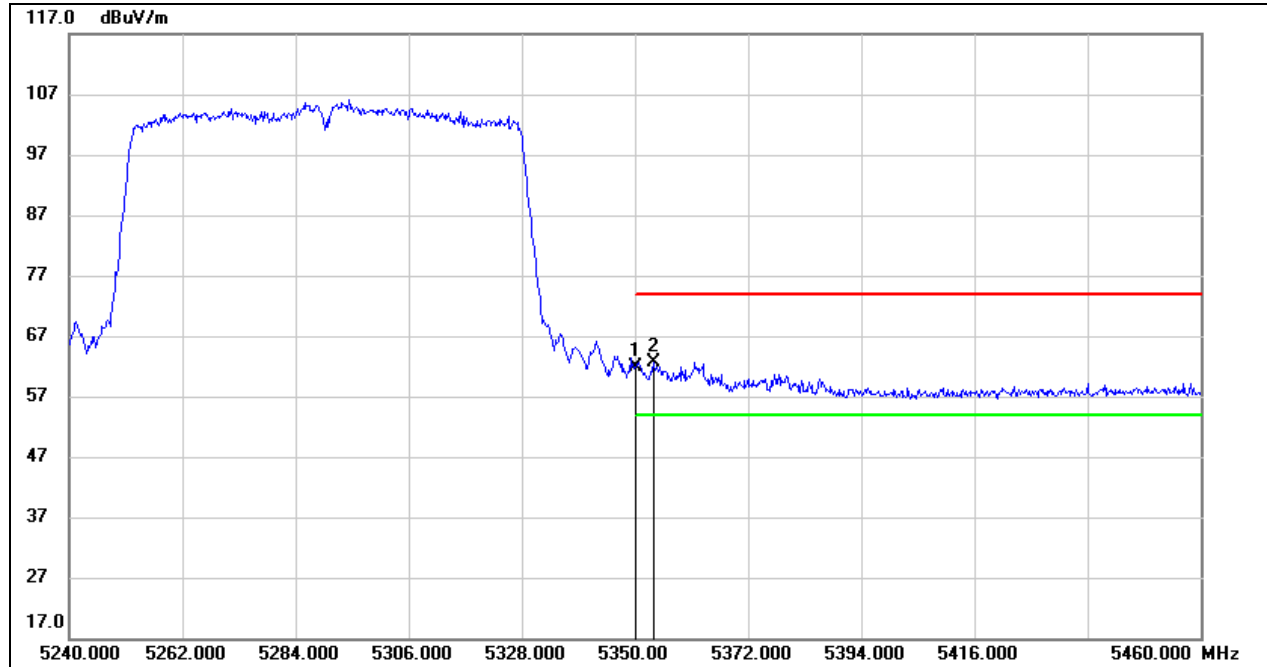

No.	Frequency (MHz)	Reading (dBuV)	Correct (dB/m)	Result (dBuV/m)	Limit (dBuV/m)	Margin (dB)	Remark
1	5350.000	20.56	41.20	61.76	74.00	-12.24	peak
2	5353.520	21.42	41.22	62.64	74.00	-11.36	peak

Note: 1. Measurement = Reading Level + Correct Factor.
 2. If Peak Result complies with AV limit, AV Result is deemed to comply with AV limit.
 3. Peak: Peak detector.
 4. Only the worst data was recorded, if it complies with the limit, the other emissions deemed to comply with the limit.

AVG

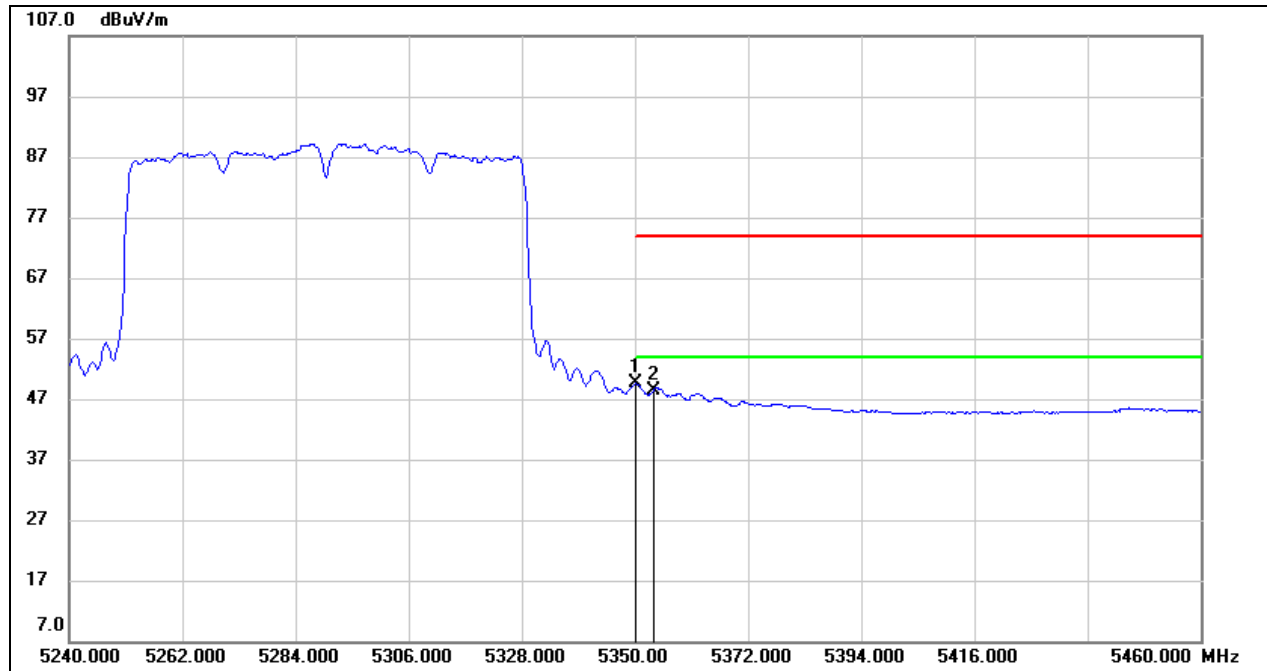

No.	Frequency (MHz)	Reading (dBuV)	Correct (dB/m)	Result (dBuV/m)	Limit (dBuV/m)	Margin (dB)	Remark
1	5350.000	8.45	41.20	49.65	54.00	-4.35	AVG
2	5353.520	7.20	41.22	48.42	54.00	-5.58	AVG

- Note:
1. Measurement = Reading Level + Correct Factor
 2. AVG: $VBW=1/Ton$ where: ton is transmit duration.
 3. For duty cycle, please refer to clause 7.1.
 4. Only the worst case emission will be recorder, if it complies with the limit, the other emissions deemed to comply with the limit.



UNII-2C BAND

RESTRICTED BANDEDGE (LOW CHANNEL, HORIZONTAL)

PEAK

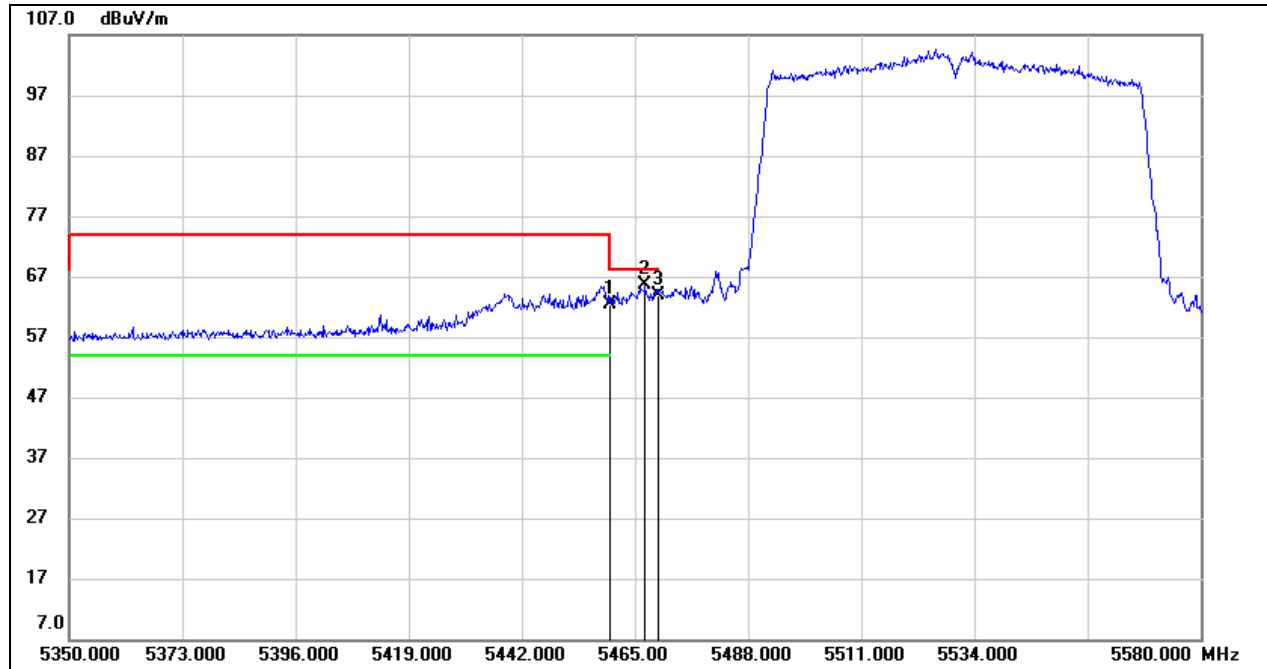

No.	Frequency (MHz)	Reading (dBuV)	Correct (dB/m)	Result (dBuV/m)	Limit (dBuV/m)	Margin (dB)	Remark
1	5460.000	20.65	41.82	62.47	68.20	-5.73	peak
2	5467.070	23.81	41.86	65.67	68.20	-2.53	peak
3	5470.000	22.07	41.87	63.94	68.20	-4.26	peak

- Note: 1. Measurement = Reading Level + Correct Factor.
 2. If Peak Result complies with AV limit, AV Result is deemed to comply with AV limit.
 3. Peak: Peak detector.
 4. Only the worst data was recorded, if it complies with the limit, the other emissions deemed to comply with the limit.

AVG

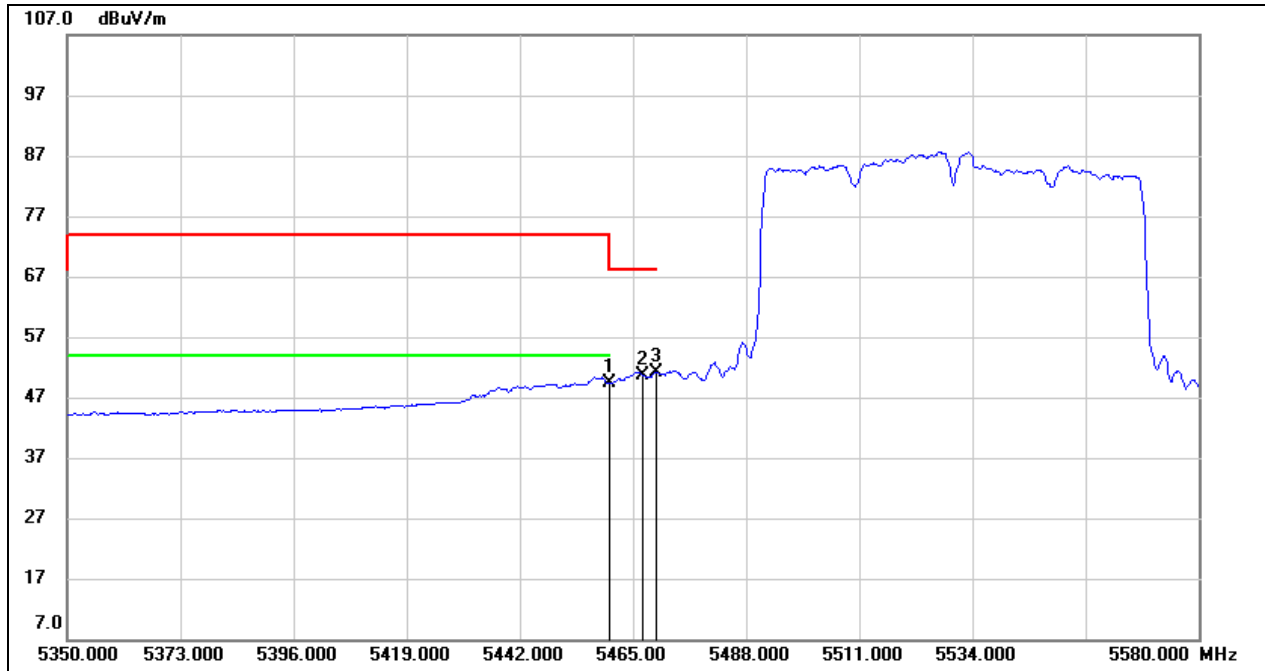

No.	Frequency (MHz)	Reading (dBuV)	Correct (dB/m)	Result (dBuV/m)	Limit (dBuV/m)	Margin (dB)	Remark
1	5460.000	7.51	41.82	49.33	54.00	-4.67	AVG
2	5467.070	8.69	41.86	50.55	/	/	AVG
3	5470.000	9.14	41.87	51.01	/	/	AVG

- Note:
1. Measurement = Reading Level + Correct Factor.
 2. If Peak Result complies with AV limit, AV Result is deemed to comply with AV limit.
 3. AVG: $VBW=1/Ton$, where: Ton is the transmitting duration.
 4. For the transmitting duration, please refer to clause 7.1.
 5. Only the worst data was recorded, if it complies with the limit, the other emissions deemed to comply with the limit.



RESTRICTED BANDEDGE (HIGH CHANNEL, HORIZONTAL)

PEAK

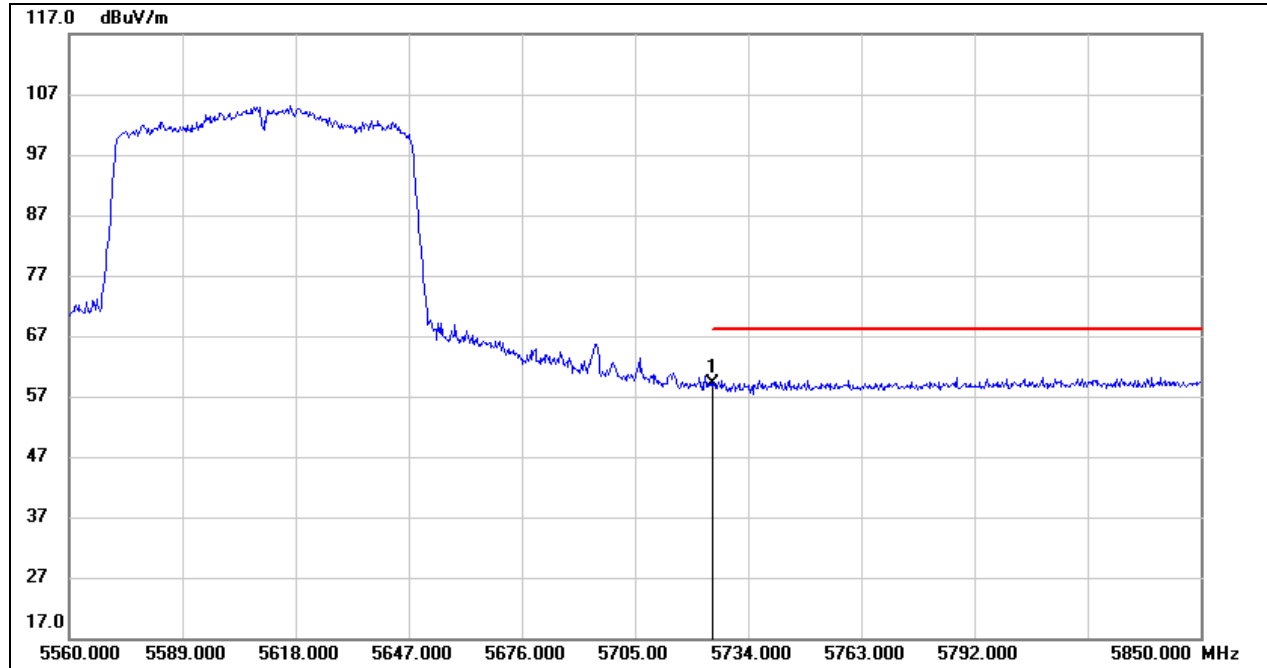

No.	Frequency (MHz)	Reading (dBuV)	Correct (dB/m)	Result (dBuV/m)	Limit (dBuV/m)	Margin (dB)	Remark
1	5725.000	17.43	41.67	59.10	68.20	-9.10	peak

- Note: 1. Measurement = Reading Level + Correct Factor.
 2. If Peak Result complies with AV limit, AV Result is deemed to comply with AV limit.
 3. Peak: Peak detector.
 4. Only the worst data was recorded, if it complies with the limit, the other emissions deemed to comply with the limit.

UNII-3 BAND

RESTRICTED BANDEDGE (LOW CHANNEL, HORIZONTAL)

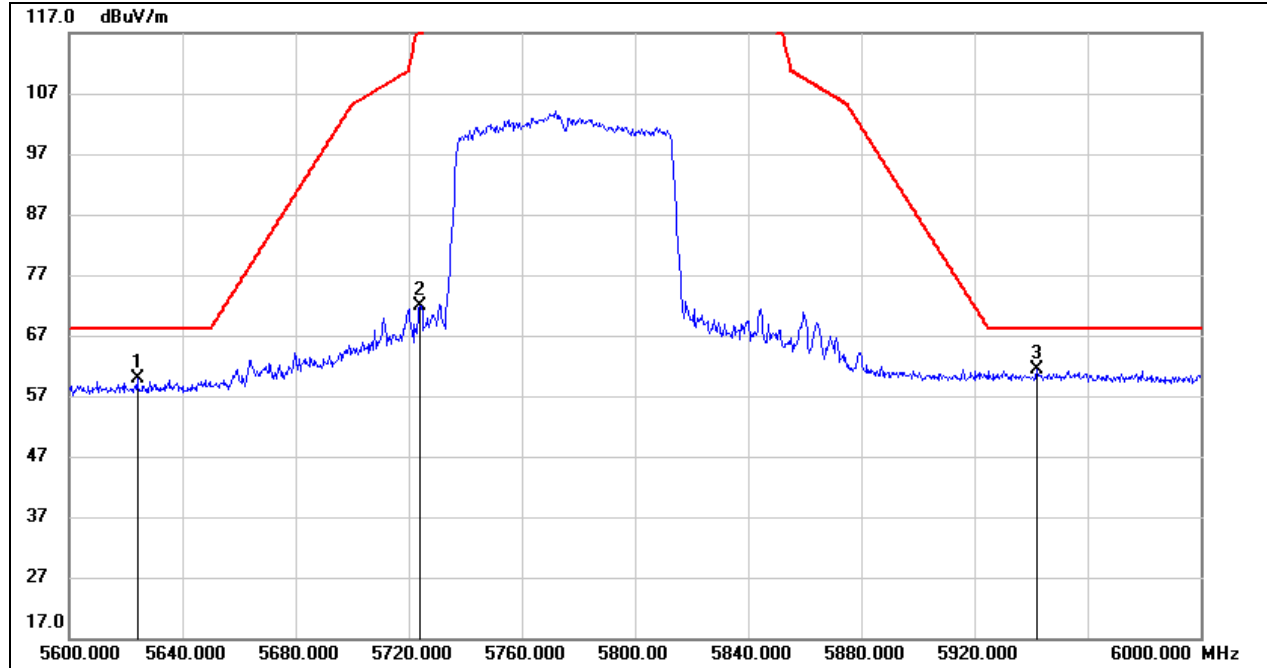

No.	Frequency (MHz)	Reading (dBuV)	Correct (dB/m)	Result (dBuV/m)	Limit (dBuV/m)	Margin (dB)	Remark
1	5624.000	18.15	41.69	59.84	68.20	-8.36	peak
2	5724.000	30.33	41.66	71.99	119.92	-47.93	peak
3	5942.000	18.55	42.83	61.38	68.20	-6.82	peak

- Note: 1. Measurement = Reading Level + Correct Factor.
 2. If Peak Result complies with AV limit, AV Result is deemed to comply with AV limit.
 3. Peak: Peak detector.
 4. Only the worst data was recorded, if it complies with the limit, the other emissions deemed to comply with the limit.

. Note: All the polarities (Vertical & Horizontal) had been tested, only the worst data was recorded in the report.

8.2. SPURIOUS EMISSIONS (1 GHz ~ 7 GHz)

8.2.1. 802.11a 20 SISO MODE

UNII-1 BAND

ANTENNA 1 MODE TEST RESULTS (WORST CASE)

HARMONICS AND SPURIOUS EMISSIONS (LOW CHANNEL, HORIZONTAL)

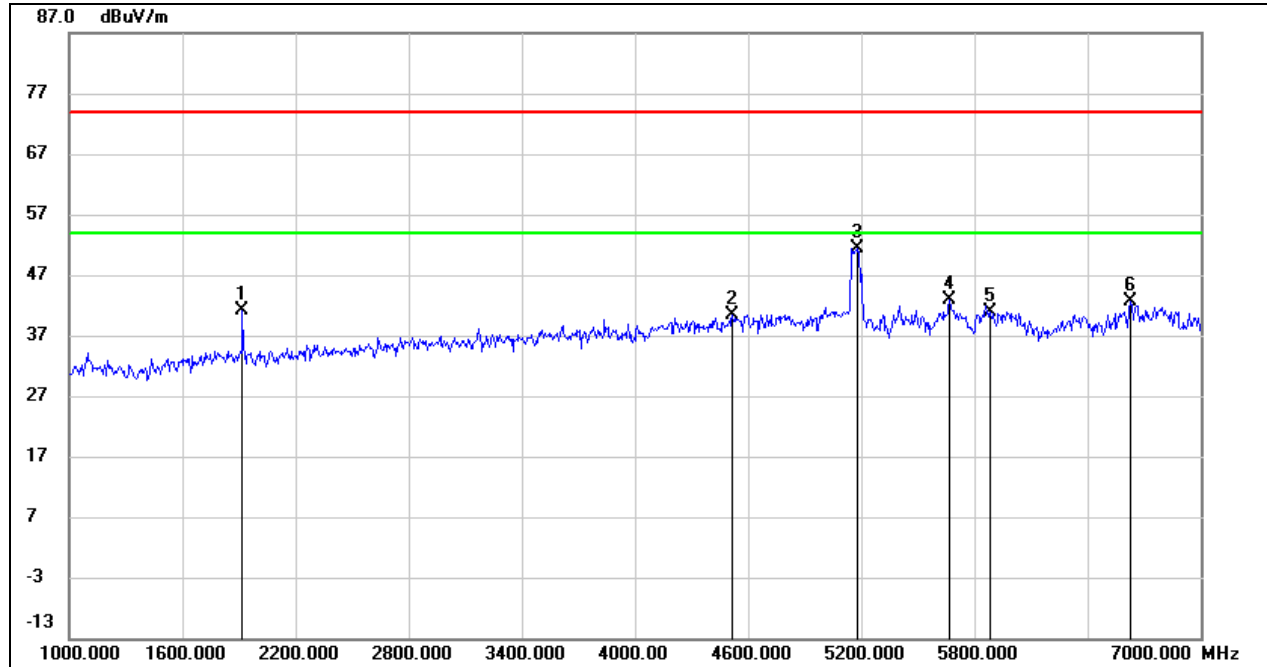

No.	Frequency (MHz)	Reading (dBuV)	Correct (dB/m)	Result (dBuV/m)	Limit (dBuV/m)	Margin (dB)	Remark
1	1918.000	51.36	-10.13	41.23	74.00	-32.77	peak
2	4516.000	41.39	-1.12	40.27	74.00	-33.73	peak
3	5180.000	49.35	1.99	51.34	/	/	fundamental
4	5668.000	40.36	2.47	42.83	74.00	-31.17	peak
5	5884.000	38.01	2.84	40.85	74.00	-33.15	peak
6	6628.000	37.18	5.50	42.68	74.00	-31.32	peak

Note: 1. Measurement = Reading Level + Correct Factor.
 2. If Peak Result complies with AV limit, AV Result is deemed to comply with AV limit.
 3. Peak: Peak detector.
 4. Filter losses were only considered in the spurious frequency bands and the authorized band was not corrected for Band reject filter losses.
 5. Proper operation of the transmitter prior to adding the filter to the measurement chain.
 6. Owing to the highest peak level of unwanted emission out of the restricted bands are lower than the line(54dBuV/m) in the graph, so all the peak test point was deemed to comply with the limits -27dBm/MHz (68.2dBuV/m) list in the standard CFR 47 FCC §15.407 (b) and ISSED RSS-247 6.2.

HARMONICS AND SPURIOUS EMISSIONS (LOW CHANNEL, VERTICAL)

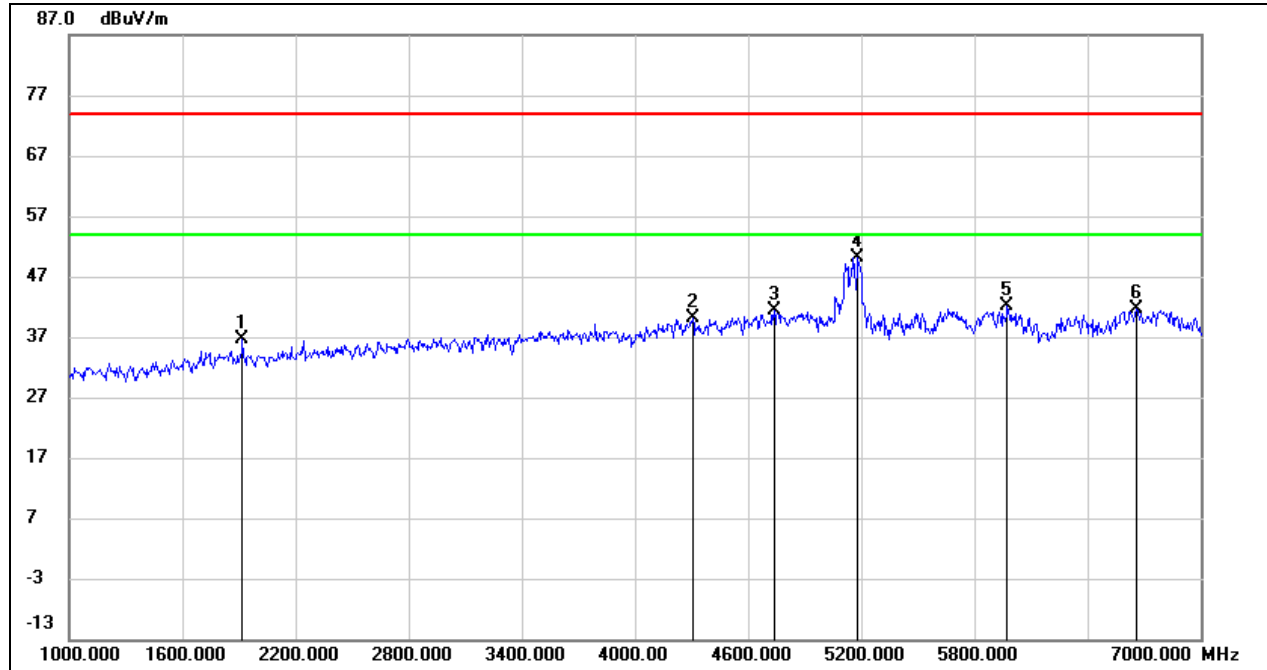

No.	Frequency (MHz)	Reading (dBuV)	Correct (dB/m)	Result (dBuV/m)	Limit (dBuV/m)	Margin (dB)	Remark
1	1918.000	46.64	-10.13	36.51	74.00	-37.49	peak
2	4306.000	41.78	-1.77	40.01	74.00	-33.99	peak
3	4738.000	41.14	0.22	41.36	74.00	-32.64	peak
4	5180.000	48.03	1.99	50.02	/	/	fundamental
5	5974.000	38.82	3.20	42.02	74.00	-31.98	peak
6	6658.000	36.10	5.51	41.61	74.00	-32.39	peak

Note: 1. Measurement = Reading Level + Correct Factor.
 2. If Peak Result complies with AV limit, AV Result is deemed to comply with AV limit.
 3. Peak: Peak detector.
 4. Filter losses were only considered in the spurious frequency bands and the authorized band was not corrected for Band reject filter losses.
 5. Proper operation of the transmitter prior to adding the filter to the measurement chain.
 6. Owing to the highest peak level of unwanted emission out of the restricted bands are lower than the line(54dBuV/m) in the graph, so all the peak test point was deemed to comply with the limits -27dBm/MHz (68.2dBuV/m) list in the standard CFR 47 FCC §15.407 (b) and ISED RSS-247 6.2.

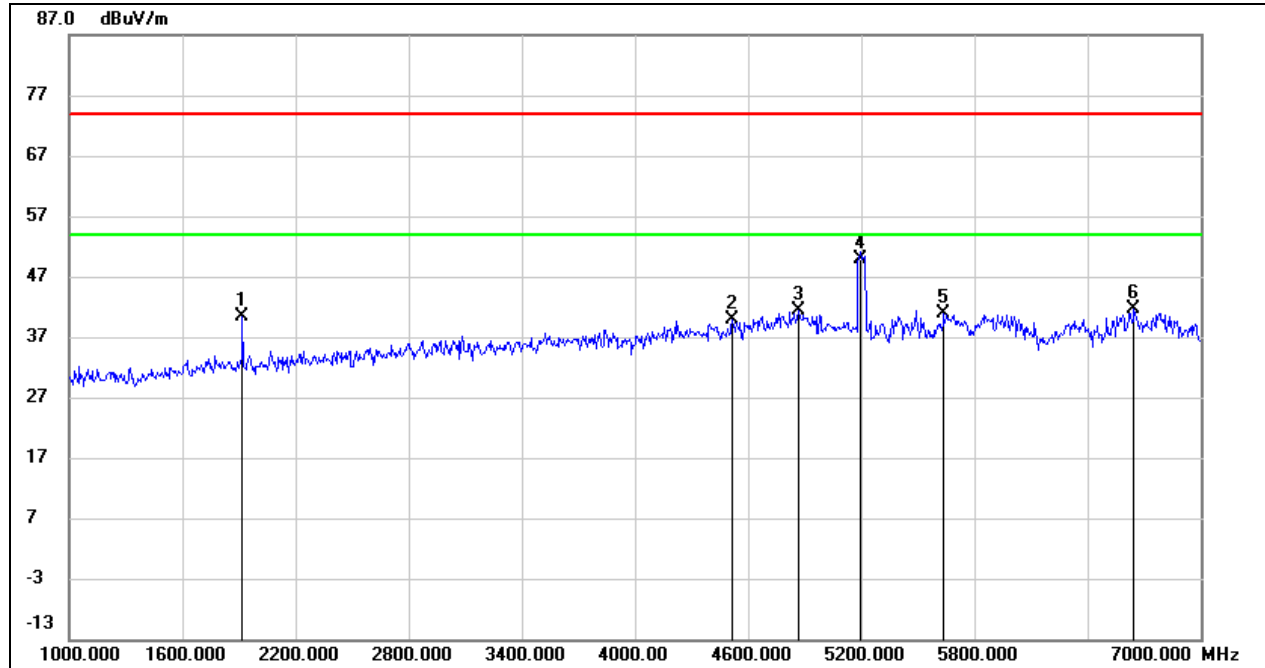
**HARMONICS AND SPURIOUS EMISSIONS (MID CHANNEL, HORIZONTAL)**

No.	Frequency (MHz)	Reading (dBuV)	Correct (dB/m)	Result (dBuV/m)	Limit (dBuV/m)	Margin (dB)	Remark
1	1920.250	50.40	-10.13	40.27	74.00	-33.73	peak
2	4516.750	41.09	-1.12	39.97	74.00	-34.03	peak
3	4872.250	40.76	0.71	41.47	74.00	-32.53	peak
4	5200.000	47.72	2.10	49.82	/	/	fundamental
5	5641.750	38.43	2.47	40.90	74.00	-33.10	peak
6	6651.250	36.02	5.52	41.54	74.00	-32.46	peak

Note: 1. Measurement = Reading Level + Correct Factor.

2. If Peak Result complies with AV limit, AV Result is deemed to comply with AV limit.

3. Peak: Peak detector.

4. Filter losses were only considered in the spurious frequency bands and the authorized band was not corrected for Band reject filter losses.

5. Proper operation of the transmitter prior to adding the filter to the measurement chain.

6. Owing to the highest peak level of unwanted emission out of the restricted bands are lower than the line(54dBuV/m) in the graph, so all the peak test point was deemed to comply with the limits -27dBm/MHz (68.2dBuV/m) list in the standard CFR 47 FCC §15.407 (b) and ISED RSS-247 6.2.

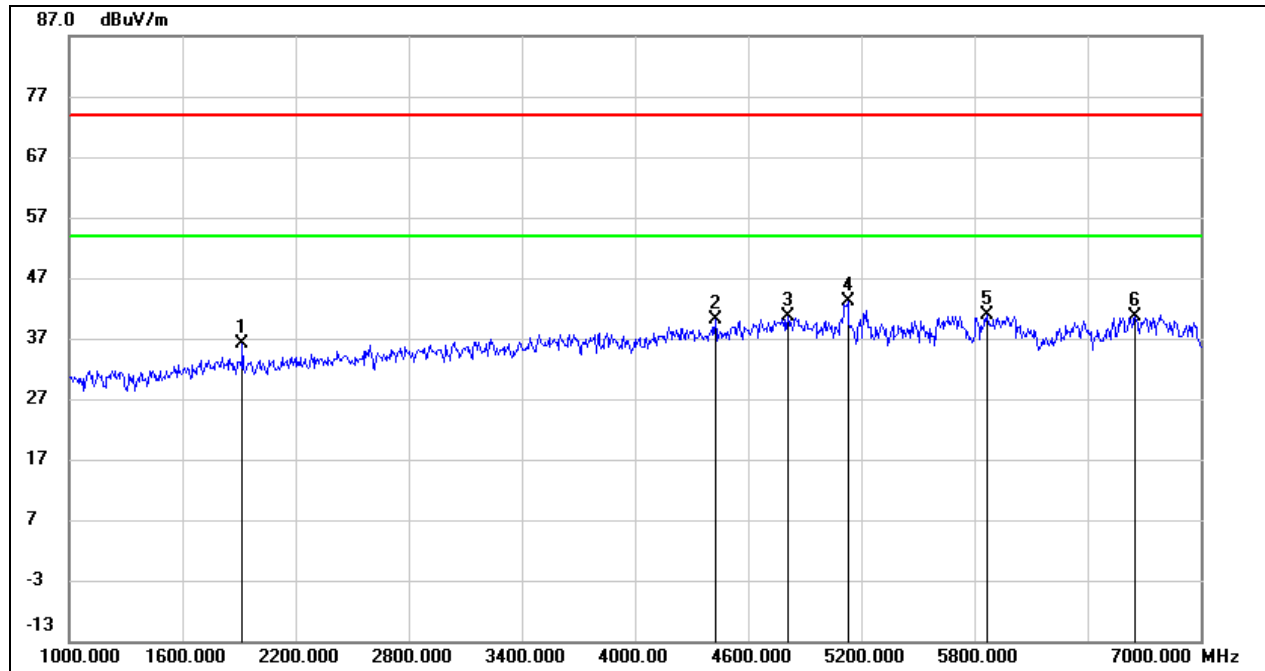
**HARMONICS AND SPURIOUS EMISSIONS (MID CHANNEL, VERTICAL)**

No.	Frequency (MHz)	Reading (dBuV)	Correct (dB/m)	Result (dBuV/m)	Limit (dBuV/m)	Margin (dB)	Remark
1	1920.250	46.16	-10.13	36.03	74.00	-37.97	peak
2	4427.500	41.85	-1.69	40.16	74.00	-33.84	peak
3	4810.000	39.98	0.60	40.58	74.00	-33.42	peak
4	5128.000	41.43	1.67	43.10	74.00	-30.90	peak
5	5869.750	38.01	2.78	40.79	74.00	-33.21	peak
6	6657.250	35.09	5.52	40.61	74.00	-33.39	peak

Note: 1. Measurement = Reading Level + Correct Factor.

2. If Peak Result complies with AV limit, AV Result is deemed to comply with AV limit.

3. Peak: Peak detector.

4. Filter losses were only considered in the spurious frequency bands and the authorized band was not corrected for Band reject filter losses.

5. Proper operation of the transmitter prior to adding the filter to the measurement chain.

6. Owing to the highest peak level of unwanted emission out of the restricted bands are lower than the line (54dBuV/m) in the graph, so all the peak test point was deemed to comply with the limits -27dBm/MHz (68.2dBuV/m) list in the standard CFR 47 FCC §15.407 (b) and ISED RSS-247 6.2.

HARMONICS AND SPURIOUS EMISSIONS (HIGH CHANNEL, HORIZONTAL)

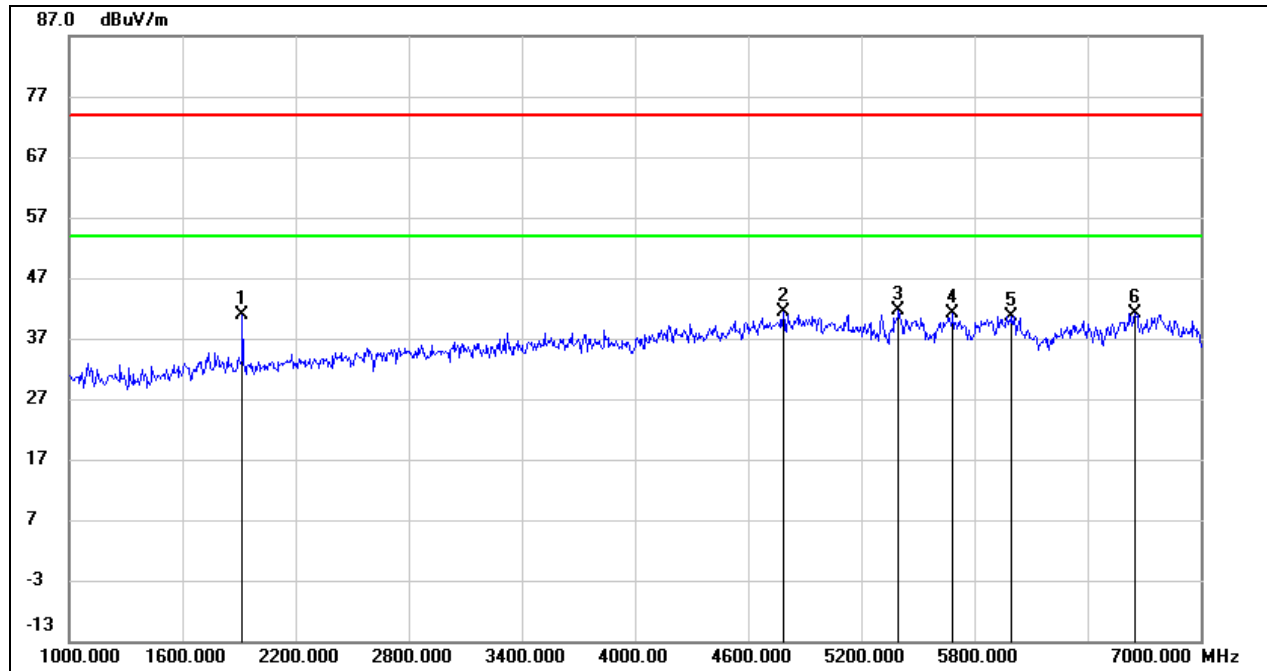

No.	Frequency (MHz)	Reading (dBuV)	Correct (dB/m)	Result (dBuV/m)	Limit (dBuV/m)	Margin (dB)	Remark
1	1920.250	51.07	-10.13	40.94	74.00	-33.06	peak
2	4786.750	40.80	0.51	41.31	74.00	-32.69	peak
3	5401.000	39.68	1.87	41.55	74.00	-32.45	peak
4	5689.750	38.57	2.48	41.05	74.00	-32.95	peak
5	5995.750	37.46	3.28	40.74	74.00	-33.26	peak
6	6654.250	35.72	5.52	41.24	74.00	-32.76	peak

Note: 1. Measurement = Reading Level + Correct Factor.
 2. If Peak Result complies with AV limit, AV Result is deemed to comply with AV limit.
 3. Peak: Peak detector.
 4. Filter losses were only considered in the spurious frequency bands and the authorized band was not corrected for Band reject filter losses.
 5. Proper operation of the transmitter prior to adding the filter to the measurement chain.
 6. Owing to the highest peak level of unwanted emission out of the restricted bands are lower than the line(54dBuV/m) in the graph, so all the peak test point was deemed to comply with the limits -27dBm/MHz (68.2dBuV/m) list in the standard CFR 47 FCC §15.407 (b) and ISED RSS-247 6.2.

HARMONICS AND SPURIOUS EMISSIONS (HIGH CHANNEL, VERTICAL)

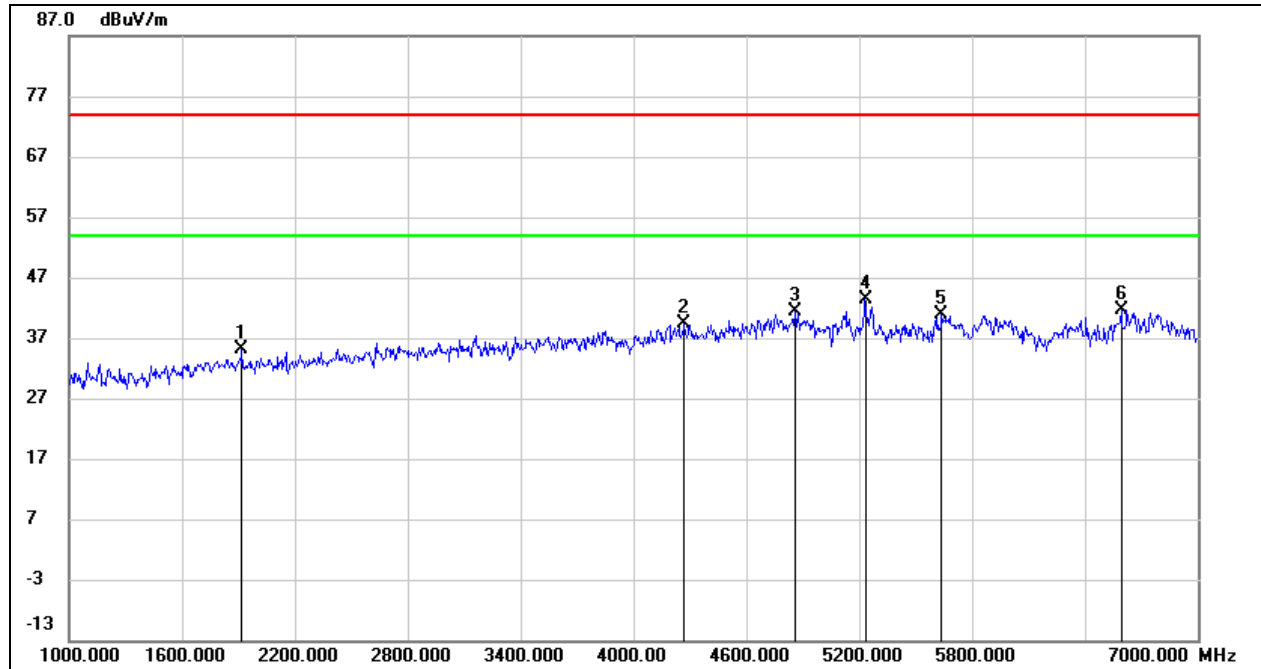

No.	Frequency (MHz)	Reading (dBuV)	Correct (dB/m)	Result (dBuV/m)	Limit (dBuV/m)	Margin (dB)	Remark
1	1920.250	45.31	-10.13	35.18	74.00	-38.82	peak
2	4270.000	41.07	-1.73	39.34	74.00	-34.66	peak
3	4859.500	40.62	0.68	41.30	74.00	-32.70	peak
4	5240.000	41.24	2.05	43.29	/	/	fundamental
5	5641.000	38.33	2.47	40.80	74.00	-33.20	peak
6	6594.250	36.19	5.46	41.65	74.00	-32.35	peak

Note: 1. Measurement = Reading Level + Correct Factor.
 2. If Peak Result complies with AV limit, AV Result is deemed to comply with AV limit.
 3. Peak: Peak detector.
 4. Filter losses were only considered in the spurious frequency bands and the authorized band was not corrected for Band reject filter losses.
 5. Proper operation of the transmitter prior to adding the filter to the measurement chain.
 6. Owing to the highest peak level of unwanted emission out of the restricted bands are lower than the line(54dBuV/m) in the graph, so all the peak test point was deemed to comply with the limits -27dBm/MHz (68.2dBuV/m) list in the standard CFR 47 FCC §15.407 (b) and ISED RSS-247 6.2.



UNII-2A BAND

ANTENNA 1 MODE TEST RESULTS (WORST CASE)

HARMONICS AND SPURIOUS EMISSIONS (LOW CHANNEL, HORIZONTAL)

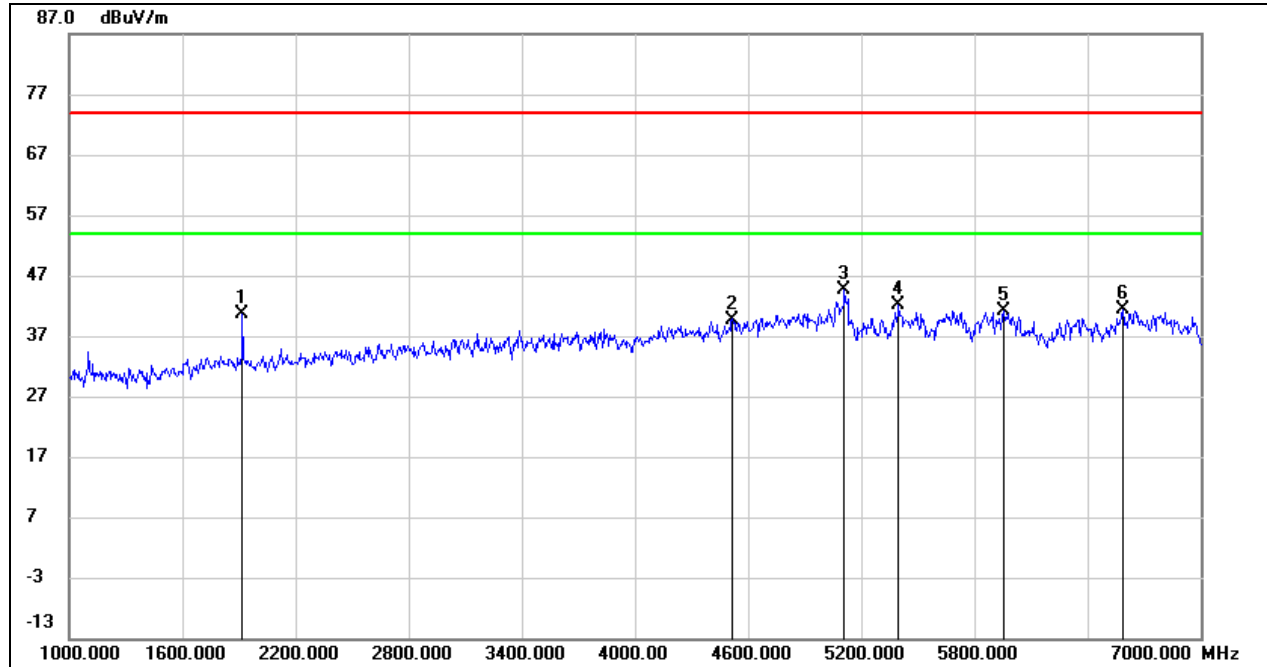

No.	Frequency (MHz)	Reading (dBuV)	Correct (dB/m)	Result (dBuV/m)	Limit (dBuV/m)	Margin (dB)	Remark
1	1920.250	50.68	-10.13	40.55	74.00	-33.45	peak
2	4516.750	40.87	-1.12	39.75	74.00	-34.25	peak
3	5115.250	43.08	1.60	44.68	74.00	-29.32	peak
4	5400.250	40.21	1.87	42.08	74.00	-31.92	peak
5	5957.500	37.99	3.14	41.13	74.00	-32.87	peak
6	6589.750	36.04	5.44	41.48	74.00	-32.52	peak

Note: 1. Measurement = Reading Level + Correct Factor.
 2. If Peak Result complies with AV limit, AV Result is deemed to comply with AV limit.
 3. Peak: Peak detector.
 4. Filter losses were only considered in the spurious frequency bands and the authorized band was not corrected for Band reject filter losses.
 5. Proper operation of the transmitter prior to adding the filter to the measurement chain.
 6. Owing to the highest peak level of unwanted emission out of the restricted bands are lower than the line(54dBuV/m) in the graph, so all the peak test point was deemed to comply with the limits -27dBm/MHz (68.2dBuV/m) list in the standard CFR 47 FCC §15.407 (b) and ISSED RSS-247 6.2.



HARMONICS AND SPURIOUS EMISSIONS (LOW CHANNEL, VERTICAL)

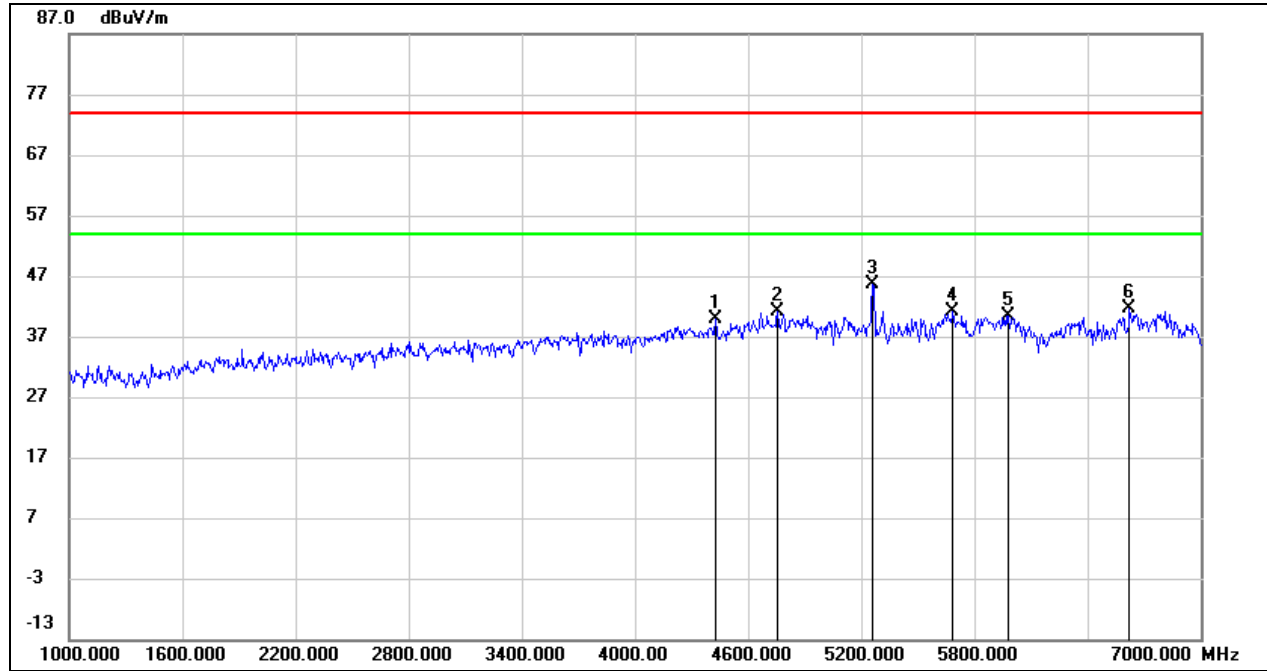

No.	Frequency (MHz)	Reading (dBuV)	Correct (dB/m)	Result (dBuV/m)	Limit (dBuV/m)	Margin (dB)	Remark
1	4429.750	41.57	-1.69	39.88	74.00	-34.12	peak
2	4756.750	40.84	0.33	41.17	74.00	-32.83	peak
3	5260.000	43.65	2.03	45.68	/	/	fundamental
4	5687.500	38.76	2.47	41.23	74.00	-32.77	peak
5	5980.750	37.23	3.22	40.45	74.00	-33.55	peak
6	6622.000	36.04	5.51	41.55	74.00	-32.45	peak

Note: 1. Measurement = Reading Level + Correct Factor.
 2. If Peak Result complies with AV limit, AV Result is deemed to comply with AV limit.
 3. Peak: Peak detector.
 4. Filter losses were only considered in the spurious frequency bands and the authorized band was not corrected for Band reject filter losses.
 5. Proper operation of the transmitter prior to adding the filter to the measurement chain.
 6. Owing to the highest peak level of unwanted emission out of the restricted bands are lower than the line(54dBuV/m) in the graph, so all the peak test point was deemed to comply with the limits -27dBm/MHz (68.2dBuV/m) list in the standard CFR 47 FCC §15.407 (b) and ISED RSS-247 6.2.

HARMONICS AND SPURIOUS EMISSIONS (MID CHANNEL, HORIZONTAL)

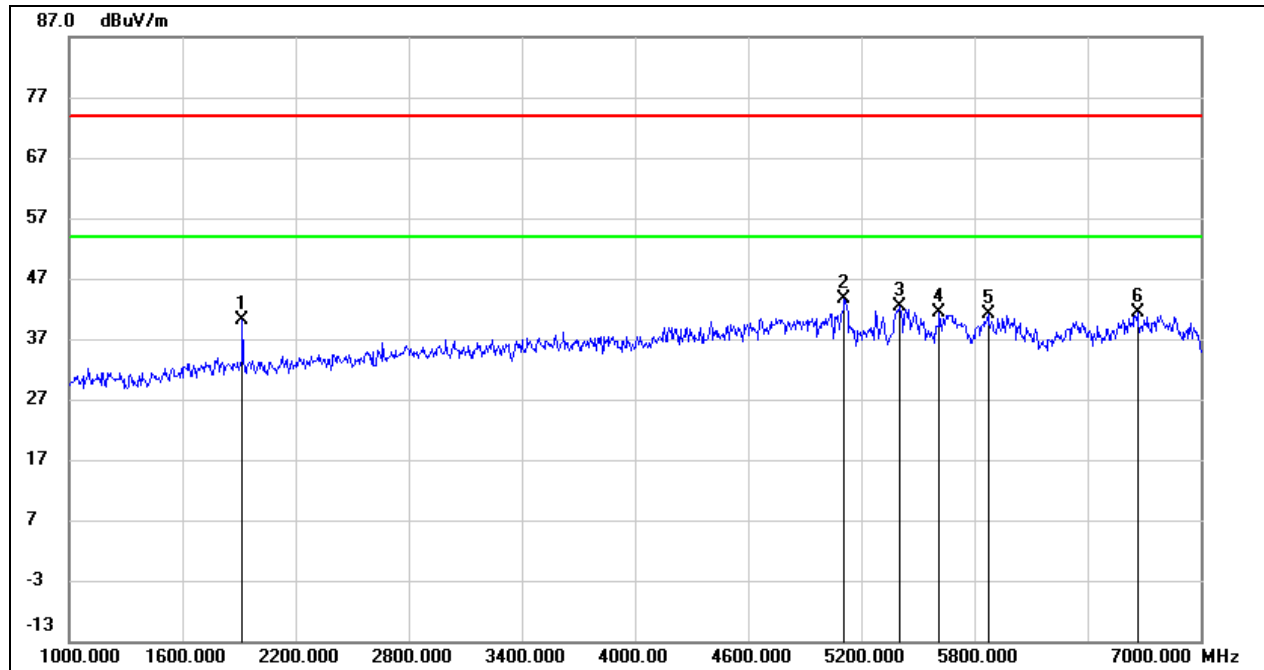

No.	Frequency (MHz)	Reading (dBuV)	Correct (dB/m)	Result (dBuV/m)	Limit (dBuV/m)	Margin (dB)	Remark
1	1920.250	50.29	-10.13	40.16	74.00	-33.84	peak
2	5115.250	42.09	1.60	43.69	74.00	-30.31	peak
3	5405.500	40.43	1.90	42.33	74.00	-31.67	peak
4	5614.750	38.93	2.46	41.39	74.00	-32.61	peak
5	5875.750	38.32	2.81	41.13	74.00	-32.87	peak
6	6665.500	35.86	5.53	41.39	74.00	-32.61	peak

Note: 1. Measurement = Reading Level + Correct Factor.
 2. If Peak Result complies with AV limit, AV Result is deemed to comply with AV limit.
 3. Peak: Peak detector.
 4. Filter losses were only considered in the spurious frequency bands and the authorized band was not corrected for Band reject filter losses.
 5. Proper operation of the transmitter prior to adding the filter to the measurement chain.
 6. Owing to the highest peak level of unwanted emission out of the restricted bands are lower than the line(54dBuV/m) in the graph, so all the peak test point was deemed to comply with the limits -27dBm/MHz (68.2dBuV/m) list in the standard CFR 47 FCC §15.407 (b) and ISED RSS-247 6.2.



HARMONICS AND SPURIOUS EMISSIONS (MID CHANNEL, VERTICAL)

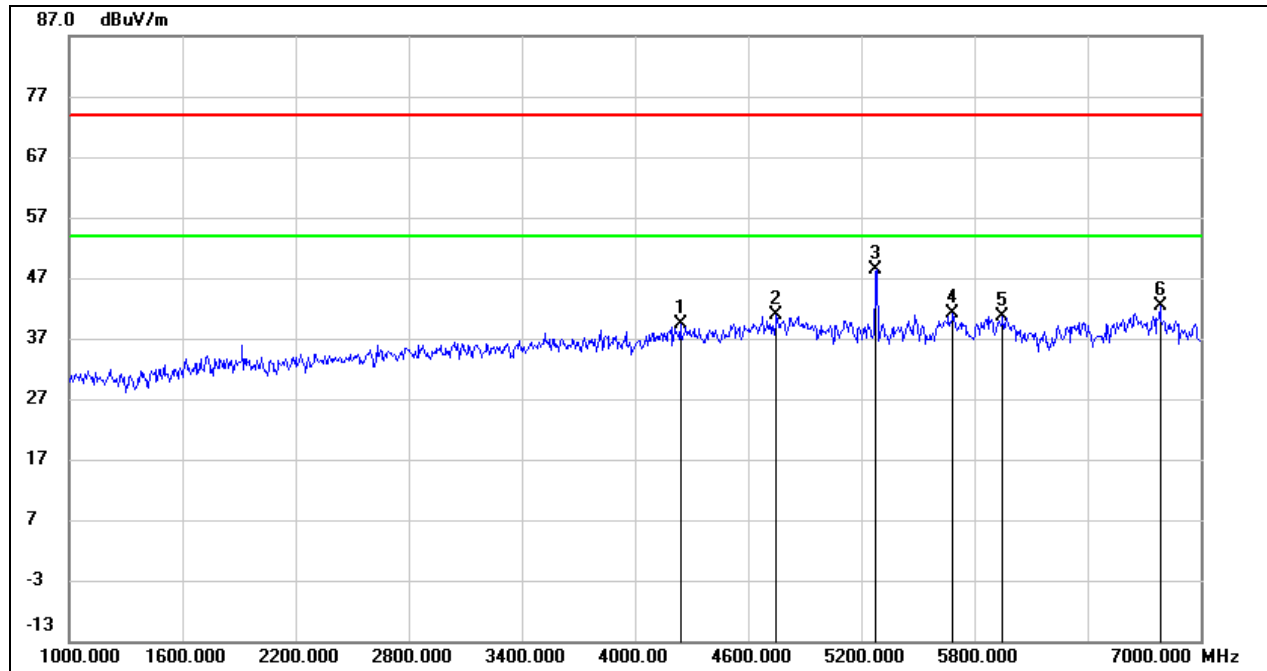

No.	Frequency (MHz)	Reading (dBuV)	Correct (dB/m)	Result (dBuV/m)	Limit (dBuV/m)	Margin (dB)	Remark
1	4244.500	40.97	-1.71	39.26	74.00	-34.74	peak
2	4750.750	40.65	0.30	40.95	74.00	-33.05	peak
3	5280.000	46.31	2.02	48.33	/	/	fundamental
4	5687.500	38.69	2.47	41.16	74.00	-32.84	peak
5	5950.750	37.52	3.10	40.62	74.00	-33.38	peak
6	6786.250	36.81	5.58	42.39	74.00	-31.61	peak

Note: 1. Measurement = Reading Level + Correct Factor.
 2. If Peak Result complies with AV limit, AV Result is deemed to comply with AV limit.
 3. Peak: Peak detector.
 4. Filter losses were only considered in the spurious frequency bands and the authorized band was not corrected for Band reject filter losses.
 5. Proper operation of the transmitter prior to adding the filter to the measurement chain.
 6. Owing to the highest peak level of unwanted emission out of the restricted bands are lower than the line(54dBuV/m) in the graph, so all the peak test point was deemed to comply with the limits -27dBm/MHz (68.2dBuV/m) list in the standard CFR 47 FCC §15.407 (b) and ISED RSS-247 6.2.



HARMONICS AND SPURIOUS EMISSIONS (HIGH CHANNEL, HORIZONTAL)

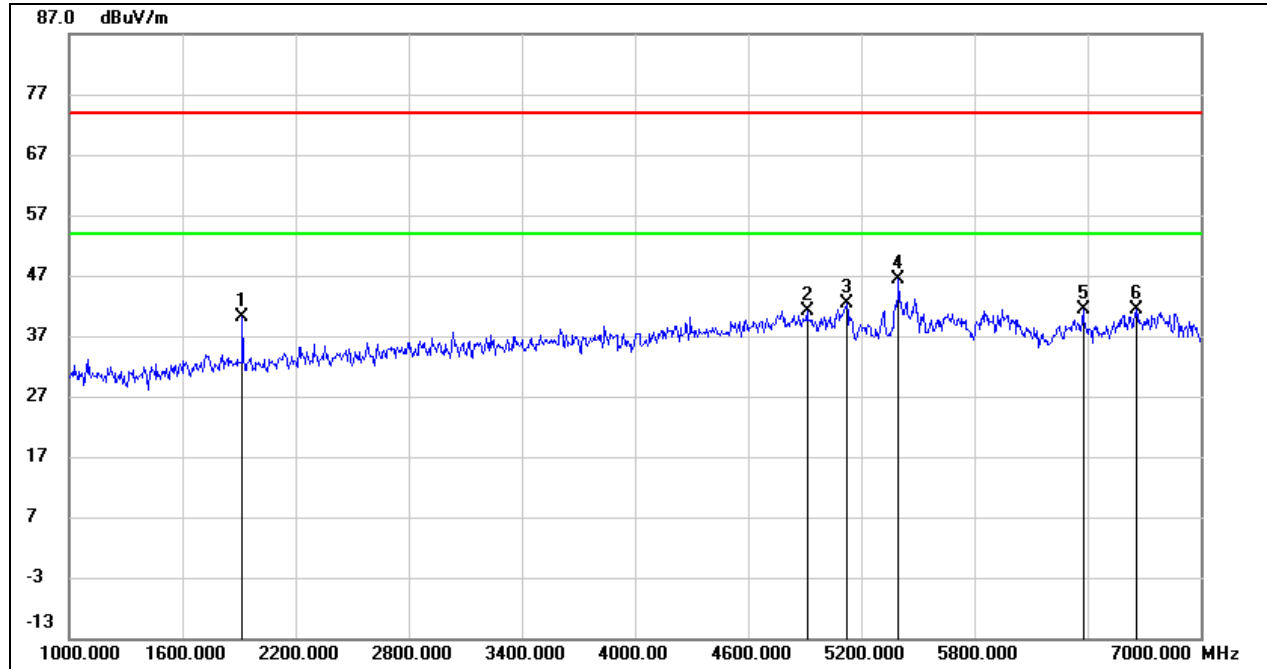

No.	Frequency (MHz)	Reading (dBuV)	Correct (dB/m)	Result (dBuV/m)	Limit (dBuV/m)	Margin (dB)	Remark
1	1920.250	50.36	-10.13	40.23	74.00	-33.77	peak
2	4915.000	40.44	0.76	41.20	74.00	-32.80	peak
3	5125.000	40.65	1.65	42.30	74.00	-31.70	peak
4	5398.750	44.47	1.87	46.34	74.00	-27.66	peak
5	6376.000	37.03	4.24	41.27	74.00	-32.73	peak
6	6658.000	35.83	5.51	41.34	74.00	-32.66	peak

Note: 1. Measurement = Reading Level + Correct Factor.
 2. If Peak Result complies with AV limit, AV Result is deemed to comply with AV limit.
 3. Peak: Peak detector.
 4. Filter losses were only considered in the spurious frequency bands and the authorized band was not corrected for Band reject filter losses.
 5. Proper operation of the transmitter prior to adding the filter to the measurement chain.
 6. Owing to the highest peak level of unwanted emission out of the restricted bands are lower than the line(54dBuV/m) in the graph, so all the peak test point was deemed to comply with the limits -27dBm/MHz (68.2dBuV/m) list in the standard CFR 47 FCC §15.407 (b) and ISSED RSS-247 6.2.

HARMONICS AND SPURIOUS EMISSIONS (HIGH CHANNEL, VERTICAL)

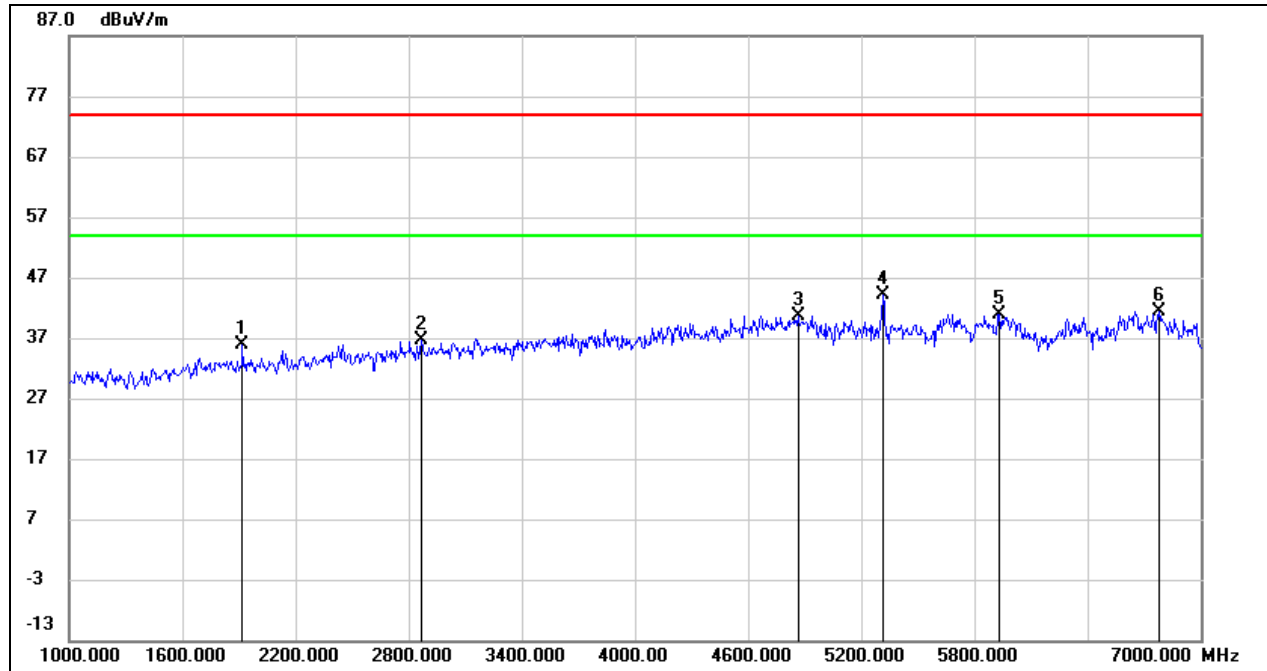

No.	Frequency (MHz)	Reading (dBuV)	Correct (dB/m)	Result (dBuV/m)	Limit (dBuV/m)	Margin (dB)	Remark
1	1920.250	46.03	-10.13	35.90	74.00	-38.10	peak
2	2868.250	42.79	-6.22	36.57	74.00	-37.43	peak
3	4867.000	40.03	0.70	40.73	74.00	-33.27	peak
4	5320.000	42.10	1.96	44.06	/	/	fundamental
5	5932.000	37.96	3.03	40.99	74.00	-33.01	peak
6	6781.750	35.83	5.57	41.40	74.00	-32.60	peak

Note: 1. Measurement = Reading Level + Correct Factor.
 2. If Peak Result complies with AV limit, AV Result is deemed to comply with AV limit.
 3. Peak: Peak detector.
 4. Filter losses were only considered in the spurious frequency bands and the authorized band was not corrected for Band reject filter losses.
 5. Proper operation of the transmitter prior to adding the filter to the measurement chain.
 6. Owing to the highest peak level of unwanted emission out of the restricted bands are lower than the line(54dBuV/m) in the graph, so all the peak test point was deemed to comply with the limits -27dBm/MHz (68.2dBuV/m) list in the standard CFR 47 FCC §15.407 (b) and ISED RSS-247 6.2.

UNII-2C BAND

ANTENNA 1 MODE TEST RESULTS (WORST CASE)

HARMONICS AND SPURIOUS EMISSIONS (LOW CHANNEL, HORIZONTAL)

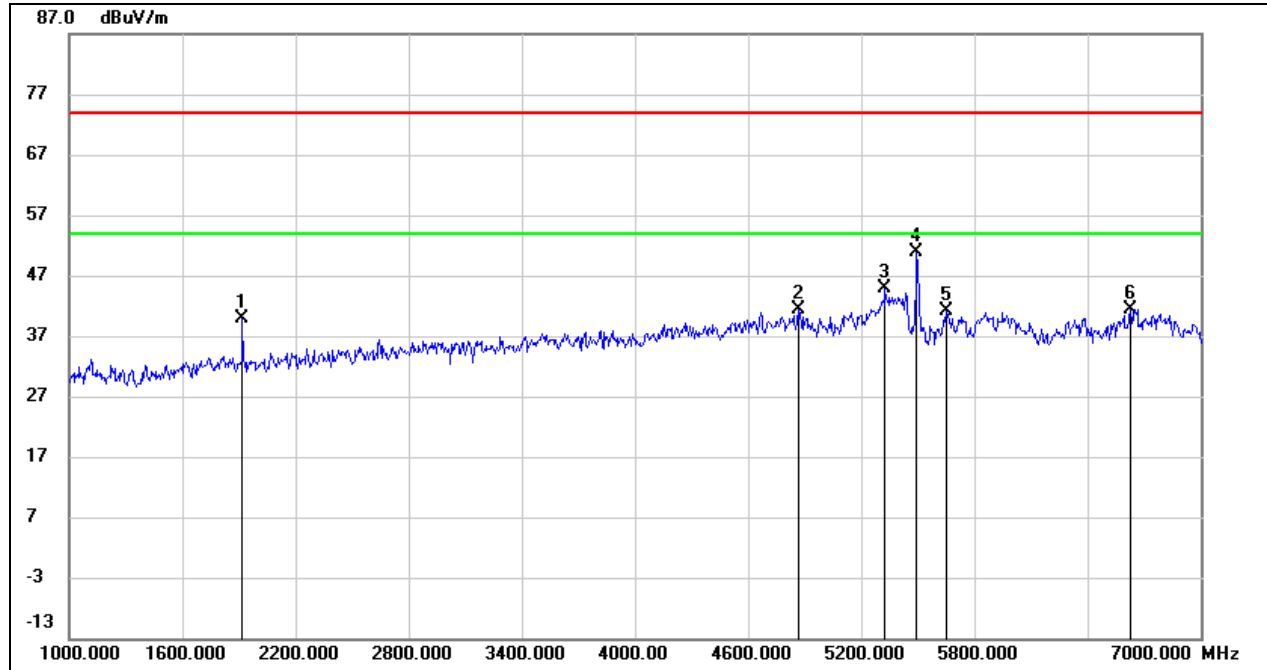

No.	Frequency (MHz)	Reading (dBuV)	Correct (dB/m)	Result (dBuV/m)	Limit (dBuV/m)	Margin (dB)	Remark
1	1920.250	49.90	-10.13	39.77	74.00	-34.23	peak
2	4866.250	40.72	0.70	41.42	74.00	-32.58	peak
3	5331.250	42.94	1.95	44.89	74.00	-29.11	peak
4	5497.000	48.62	2.16	50.78	74.00	-23.22	peak
5	5652.250	38.59	2.46	41.05	74.00	-32.95	peak
6	6629.500	35.95	5.51	41.46	74.00	-32.54	peak

Note: 1. Measurement = Reading Level + Correct Factor.
 2. If Peak Result complies with AV limit, AV Result is deemed to comply with AV limit.
 3. Peak: Peak detector.
 4. Filter losses were only considered in the spurious frequency bands and the authorized band was not corrected for Band reject filter losses.
 5. Proper operation of the transmitter prior to adding the filter to the measurement chain.
 6. Owing to the highest peak level of unwanted emission out of the restricted bands are lower than the line(54dBuV/m) in the graph, so all the peak test point was deemed to comply with the limits -27dBm/MHz (68.2dBuV/m) list in the standard CFR 47 FCC §15.407 (b) and ISSED RSS-247 6.2.

HARMONICS AND SPURIOUS EMISSIONS (LOW CHANNEL, VERTICAL)

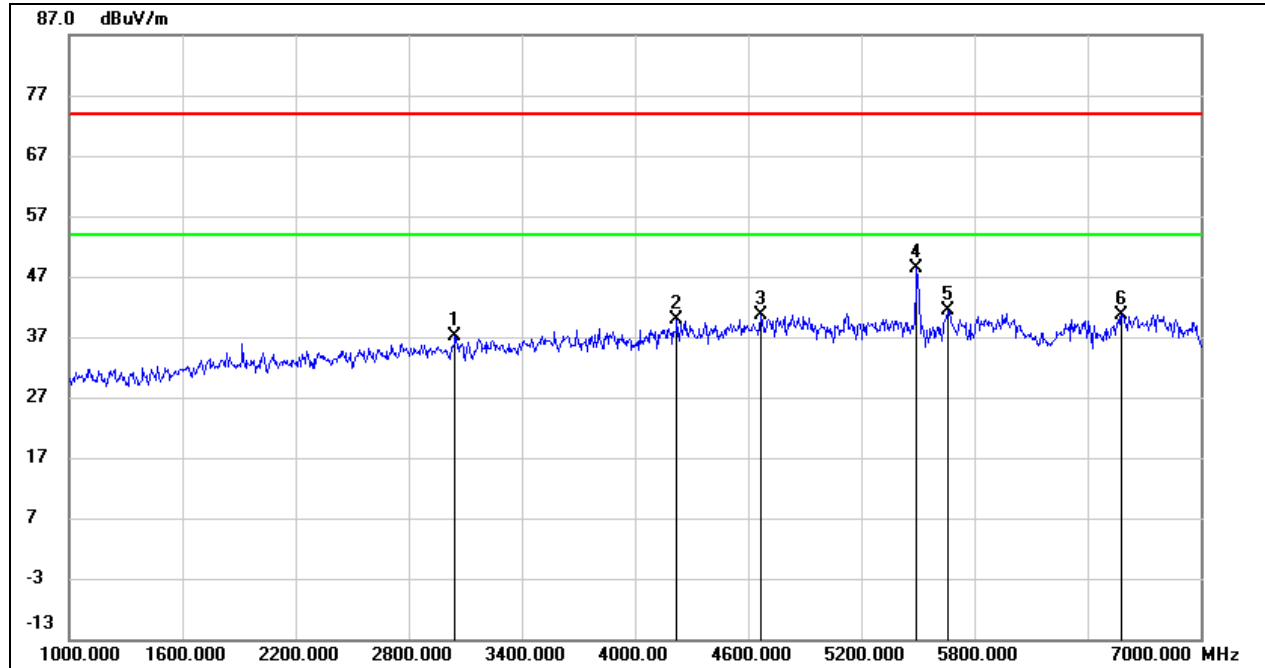

No.	Frequency (MHz)	Reading (dBuV)	Correct (dB/m)	Result (dBuV/m)	Limit (dBuV/m)	Margin (dB)	Remark
1	3050.500	42.61	-5.50	37.11	74.00	-36.89	peak
2	4225.000	41.54	-1.68	39.86	74.00	-34.14	peak
3	4669.000	40.86	-0.17	40.69	74.00	-33.31	peak
4	5498.500	46.11	2.16	48.27	74.00	-25.73	peak
5	5667.250	38.98	2.48	41.46	74.00	-32.54	peak
6	6581.500	35.34	5.40	40.74	74.00	-33.26	peak

Note: 1. Measurement = Reading Level + Correct Factor.

2. If Peak Result complies with AV limit, AV Result is deemed to comply with AV limit.

3. Peak: Peak detector.

4. Filter losses were only considered in the spurious frequency bands and the authorized band was not corrected for Band reject filter losses.

5. Proper operation of the transmitter prior to adding the filter to the measurement chain.

6. Owing to the highest peak level of unwanted emission out of the restricted bands are lower than the line(54dBuV/m) in the graph, so all the peak test point was deemed to comply with the limits -27dBm/MHz (68.2dBuV/m) list in the standard CFR 47 FCC §15.407 (b) and ISED RSS-247 6.2.

HARMONICS AND SPURIOUS EMISSIONS (MID CHANNEL, HORIZONTAL)

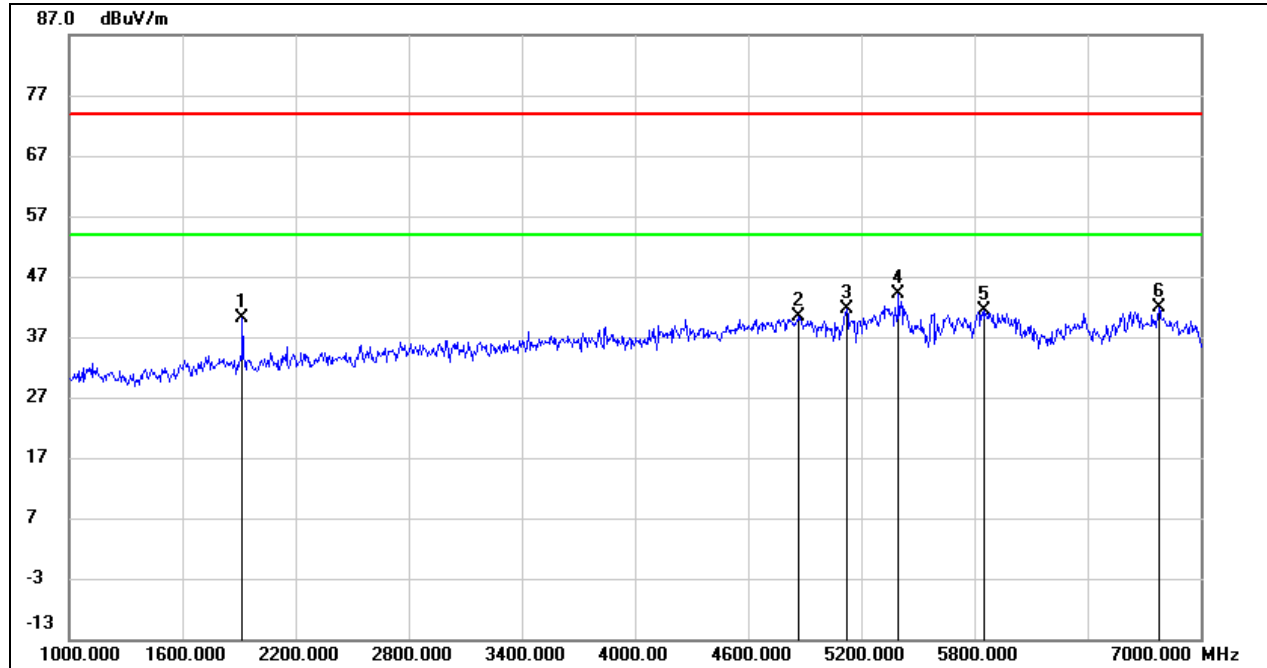

No.	Frequency (MHz)	Reading (dBuV)	Correct (dB/m)	Result (dBuV/m)	Limit (dBuV/m)	Margin (dB)	Remark
1	1920.250	50.36	-10.13	40.23	74.00	-33.77	peak
2	4866.250	39.70	0.70	40.40	74.00	-33.60	peak
3	5126.500	40.07	1.66	41.73	74.00	-32.27	peak
4	5400.250	42.24	1.87	44.11	74.00	-29.89	peak
5	5859.250	38.56	2.75	41.31	74.00	-32.69	peak
6	6779.500	36.33	5.56	41.89	74.00	-32.11	peak

Note: 1. Measurement = Reading Level + Correct Factor.
 2. If Peak Result complies with AV limit, AV Result is deemed to comply with AV limit.
 3. Peak: Peak detector.
 4. Filter losses were only considered in the spurious frequency bands and the authorized band was not corrected for Band reject filter losses.
 5. Proper operation of the transmitter prior to adding the filter to the measurement chain.
 6. Owing to the highest peak level of unwanted emission out of the restricted bands are lower than the line(54dBuV/m) in the graph, so all the peak test point was deemed to comply with the limits -27dBm/MHz (68.2dBuV/m) list in the standard CFR 47 FCC §15.407 (b) and ISSED RSS-247 6.2.

HARMONICS AND SPURIOUS EMISSIONS (MID CHANNEL, VERTICAL)

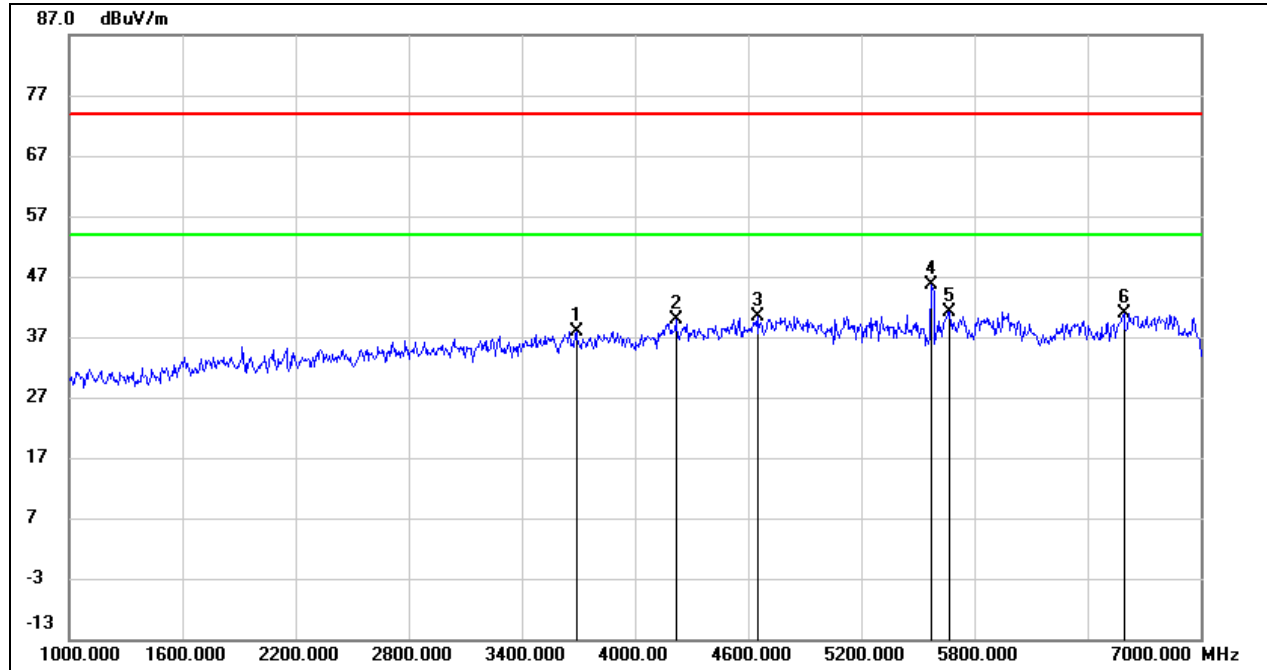

No.	Frequency (MHz)	Reading (dBuV)	Correct (dB/m)	Result (dBuV/m)	Limit (dBuV/m)	Margin (dB)	Remark
1	3688.000	41.67	-3.78	37.89	74.00	-36.11	peak
2	4216.000	41.69	-1.69	40.00	74.00	-34.00	peak
3	4649.500	40.75	-0.28	40.47	74.00	-33.53	peak
4	5575.000	43.32	2.38	45.70	74.00	-28.30	peak
5	5671.000	38.60	2.48	41.08	74.00	-32.92	peak
6	6593.500	35.49	5.46	40.95	74.00	-33.05	peak

Note: 1. Measurement = Reading Level + Correct Factor.
 2. If Peak Result complies with AV limit, AV Result is deemed to comply with AV limit.
 3. Peak: Peak detector.
 4. Filter losses were only considered in the spurious frequency bands and the authorized band was not corrected for Band reject filter losses.
 5. Proper operation of the transmitter prior to adding the filter to the measurement chain.
 6. Owing to the highest peak level of unwanted emission out of the restricted bands are lower than the line(54dBuV/m) in the graph, so all the peak test point was deemed to comply with the limits -27dBm/MHz (68.2dBuV/m) list in the standard CFR 47 FCC §1 5.407 (b) and ISED RSS-247 6.2.



HARMONICS AND SPURIOUS EMISSIONS (HIGH CHANNEL, HORIZONTAL)

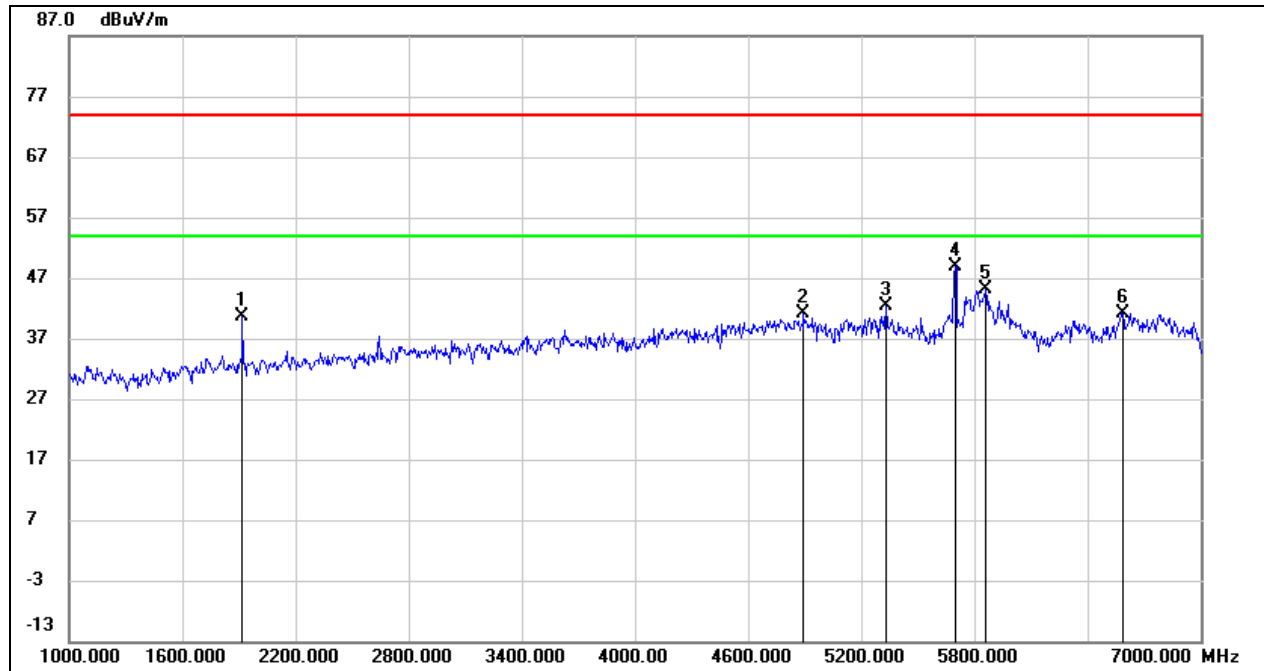

No.	Frequency (MHz)	Reading (dBuV)	Correct (dB/m)	Result (dBuV/m)	Limit (dBuV/m)	Margin (dB)	Remark
1	1920.250	50.82	-10.13	40.69	74.00	-33.31	peak
2	4899.250	40.33	0.74	41.07	74.00	-32.93	peak
3	5335.750	40.34	1.94	42.28	74.00	-31.72	peak
4	5700.000	46.51	2.48	48.99	/	/	fundamental
5	5863.000	42.32	2.76	45.08	74.00	-28.92	peak
6	6586.000	35.81	5.41	41.22	74.00	-32.78	peak

Note: 1. Measurement = Reading Level + Correct Factor.
 2. If Peak Result complies with AV limit, AV Result is deemed to comply with AV limit.
 3. Peak: Peak detector.
 4. Filter losses were only considered in the spurious frequency bands and the authorized band was not corrected for Band reject filter losses.
 5. Proper operation of the transmitter prior to adding the filter to the measurement chain.
 6. Owing to the highest peak level of unwanted emission out of the restricted bands are lower than the line(54dBuV/m) in the graph, so all the peak test point was deemed to comply with the limits -27dBm/MHz (68.2dBuV/m) list in the standard CFR 47 FCC §15.407 (b) and ISED RSS-247 6.2.



HARMONICS AND SPURIOUS EMISSIONS (HIGH CHANNEL, VERTICAL)

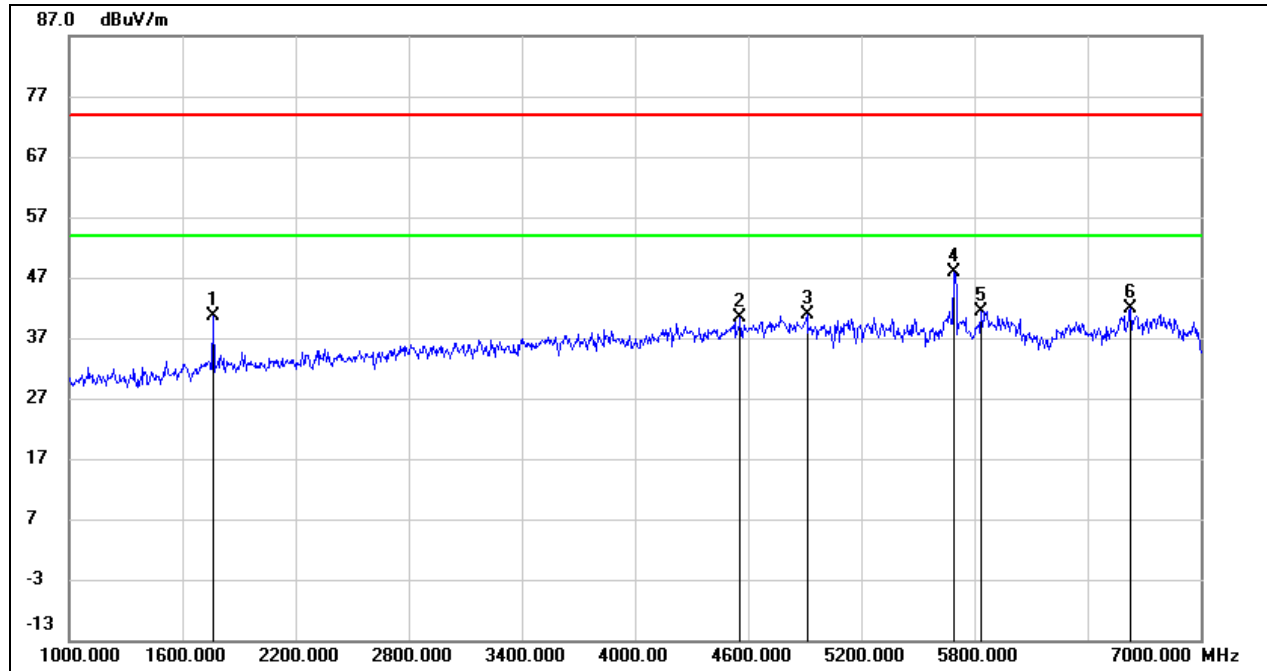

No.	Frequency (MHz)	Reading (dBuV)	Correct (dB/m)	Result (dBuV/m)	Limit (dBuV/m)	Margin (dB)	Remark
1	1765.750	50.96	-10.31	40.65	74.00	-33.35	peak
2	4560.250	41.23	-0.84	40.39	74.00	-33.61	peak
3	4912.000	40.22	0.77	40.99	74.00	-33.01	peak
4	5697.250	45.30	2.49	47.79	74.00	-26.21	peak
5	5840.500	38.82	2.67	41.49	74.00	-32.51	peak
6	6628.000	36.39	5.50	41.89	74.00	-32.11	peak

Note: 1. Measurement = Reading Level + Correct Factor.
 2. If Peak Result complies with AV limit, AV Result is deemed to comply with AV limit.
 3. Peak: Peak detector.
 4. Filter losses were only considered in the spurious frequency bands and the authorized band was not corrected for Band reject filter losses.
 5. Proper operation of the transmitter prior to adding the filter to the measurement chain.
 6. Owing to the highest peak level of unwanted emission out of the restricted bands are lower than the line(54dBuV/m) in the graph, so all the peak test point was deemed to comply with the limits -27dBm/MHz (68.2dBuV/m) list in the standard CFR 47 FCC §15.407 (b) and ISED RSS-247 6.2.



STRADDLE CHANNEL 144

ANTENNA 1 MODE TEST RESULTS (WORST CASE)

HARMONICS AND SPURIOUS EMISSIONS (HORIZONTAL)

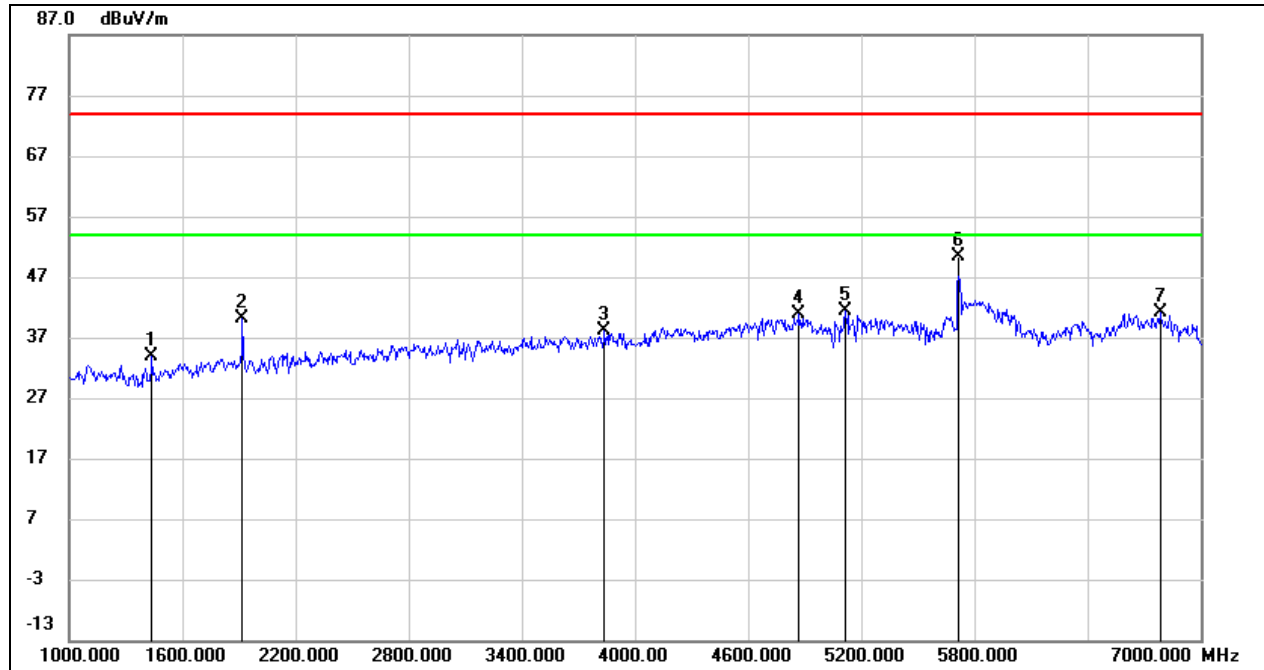

No.	Frequency (MHz)	Reading (dBuV)	Correct (dB/m)	Result (dBuV/m)	Limit (dBuV/m)	Margin (dB)	Remark
1	1441.750	46.28	-12.50	33.78	74.00	-40.22	peak
2	1920.250	50.14	-10.13	40.01	74.00	-33.99	peak
3	3840.250	41.35	-3.33	38.02	74.00	-35.98	peak
4	4871.500	40.09	0.71	40.80	74.00	-33.20	peak
5	5117.500	39.79	1.61	41.40	74.00	-32.60	peak
6	5720.000	47.91	2.48	50.39	/	/	fundamental
7	6785.500	35.66	5.57	41.23	74.00	-32.77	peak

Note: 1. Measurement = Reading Level + Correct Factor.
 2. If Peak Result complies with AV limit, AV Result is deemed to comply with AV limit.
 3. Peak: Peak detector.
 4. Filter losses were only considered in the spurious frequency bands and the authorized band was not corrected for Band reject filter losses.
 5. Proper operation of the transmitter prior to adding the filter to the measurement chain.
 6. Owing to the highest peak level of unwanted emission out of the restricted bands are lower than the line(54dBuV/m) in the graph, so all the peak test point was deemed to comply with the limits -27dBm/MHz (68.2dBuV/m) list in the standard CFR 47 FCC §15.407 (b) and ISED RSS-247 6.2.

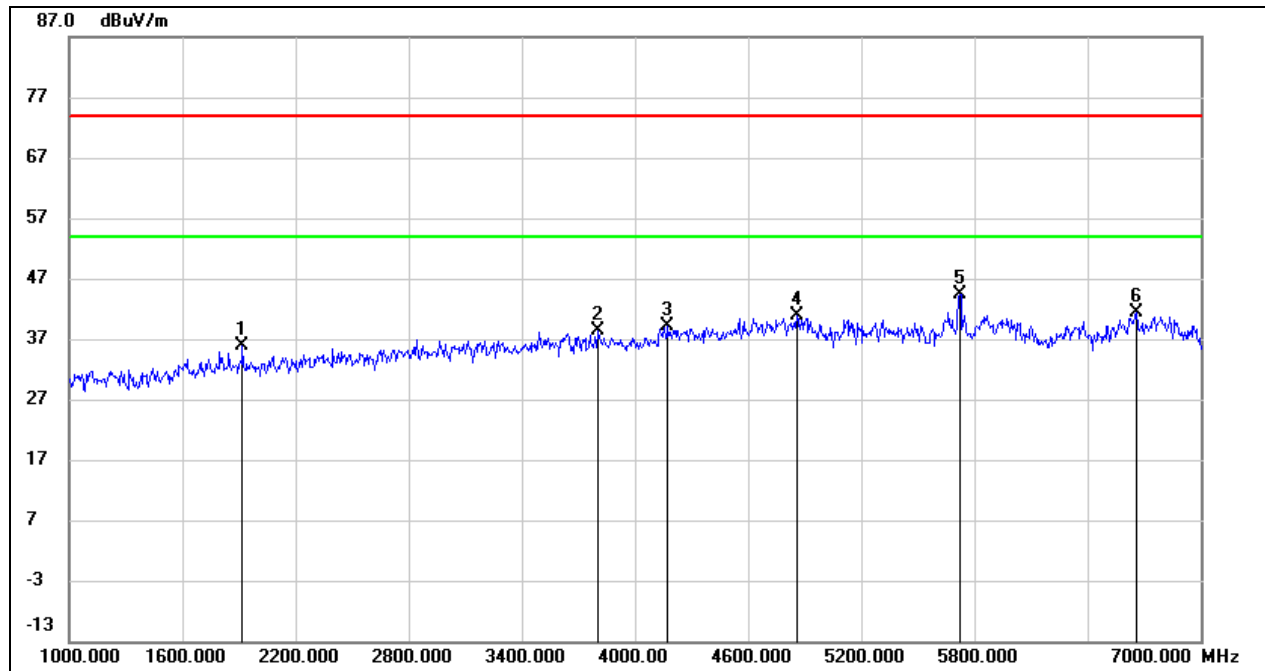
**HARMONICS AND SPURIOUS EMISSIONS (VERTICAL)**

No.	Frequency (MHz)	Reading (dBuV)	Correct (dB/m)	Result (dBuV/m)	Limit (dBuV/m)	Margin (dB)	Remark
1	1920.250	46.01	-10.13	35.88	74.00	-38.12	peak
2	3806.500	41.59	-3.27	38.32	74.00	-35.68	peak
3	4177.000	40.96	-1.89	39.07	74.00	-34.93	peak
4	4863.250	40.22	0.68	40.90	74.00	-33.10	peak
5	5724.250	41.95	2.48	44.43	74.00	-29.57	peak
6	6662.500	35.97	5.51	41.48	74.00	-32.52	peak

Note: 1. Measurement = Reading Level + Correct Factor.

2. If Peak Result complies with AV limit, AV Result is deemed to comply with AV limit.

3. Peak: Peak detector.

4. Filter losses were only considered in the spurious frequency bands and the authorized band was not corrected for Band reject filter losses.

5. Proper operation of the transmitter prior to adding the filter to the measurement chain.

6. Owing to the highest peak level of unwanted emission out of the restricted bands are lower than the line(54dBuV/m) in the graph, so all the peak test point was deemed to comply with the limits -27dBm/MHz (68.2dBuV/m) list in the standard CFR 47 FCC §15.407 (b) and ISSED RSS-247 6.2.



UNII-3 BAND

ANTENNA 1 MODE TEST RESULTS (WORST CASE)

HARMONICS AND SPURIOUS EMISSIONS (LOW CHANNEL, HORIZONTAL)

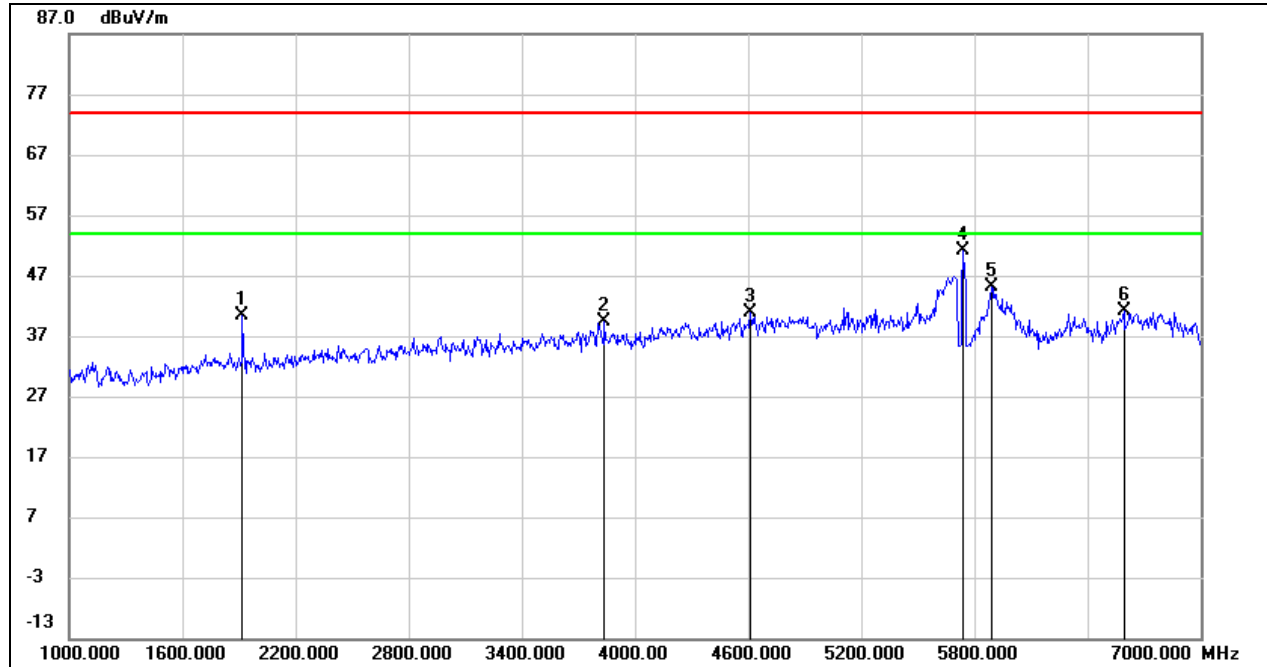

No.	Frequency (MHz)	Reading (dBuV)	Correct (dB/m)	Result (dBuV/m)	Limit (dBuV/m)	Margin (dB)	Remark
1	1920.250	50.53	-10.13	40.40	74.00	-33.60	peak
2	3840.250	42.65	-3.33	39.32	74.00	-34.68	peak
3	4612.000	41.45	-0.49	40.96	74.00	-33.04	peak
4	5745.000	48.76	2.49	51.25	/	/	fundamental
5	5891.500	42.25	2.87	45.12	74.00	-28.88	peak
6	6592.750	35.79	5.46	41.25	74.00	-32.75	peak

Note: 1. Measurement = Reading Level + Correct Factor.
 2. If Peak Result complies with AV limit, AV Result is deemed to comply with AV limit.
 3. Peak: Peak detector.
 4. Filter losses were only considered in the spurious frequency bands and the authorized band was not corrected for Band reject filter losses.
 5. Proper operation of the transmitter prior to adding the filter to the measurement chain.
 6. Owing to the highest peak level of unwanted emission out of the restricted bands are lower than the line(54dBuV/m) in the graph, so all the peak test point was deemed to comply with the limits -27dBm/MHz (68.2dBuV/m) list in the standard CFR 47 FCC §15.407 (b) and ISED RSS-247 6.2.



HARMONICS AND SPURIOUS EMISSIONS (LOW CHANNEL, VERTICAL)

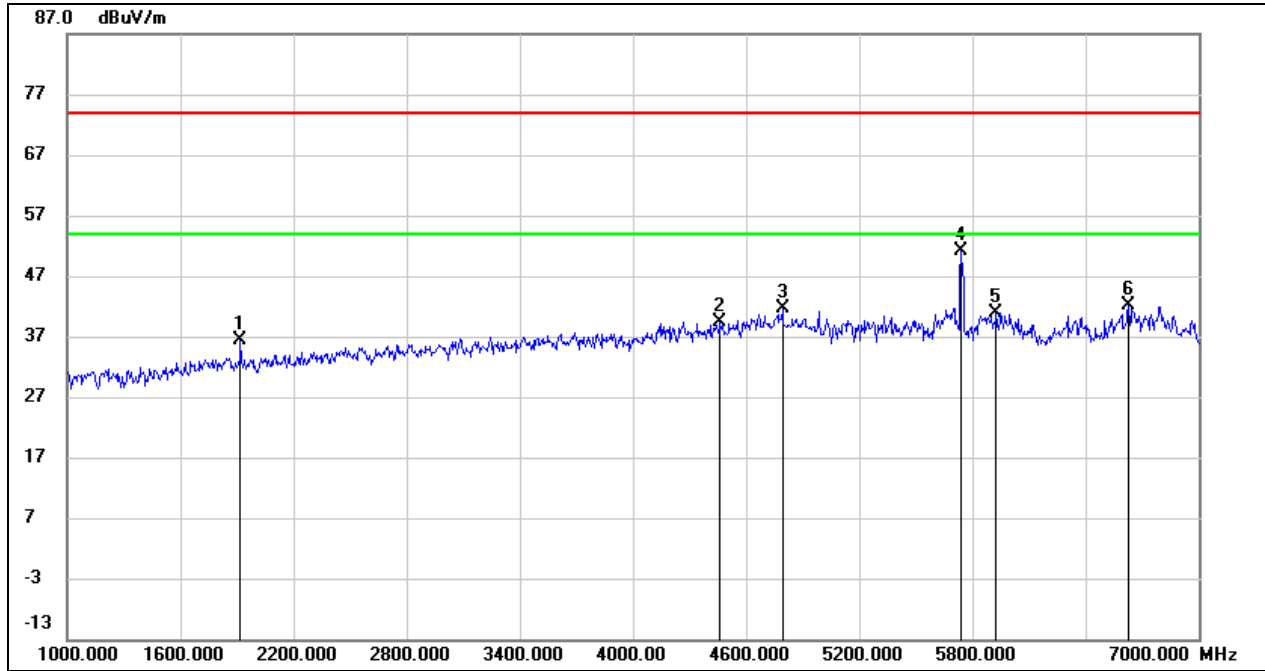

No.	Frequency (MHz)	Reading (dBuV)	Correct (dB/m)	Result (dBuV/m)	Limit (dBuV/m)	Margin (dB)	Remark
1	1920.250	46.49	-10.13	36.36	74.00	-37.64	peak
2	4463.500	40.92	-1.47	39.45	74.00	-34.55	peak
3	4793.500	41.07	0.56	41.63	74.00	-32.37	peak
4	5745.000	48.62	2.49	/	/	fundamental	
5	5926.000	37.84	3.01	40.85	74.00	-33.15	peak
6	6628.000	36.69	5.50	42.19	74.00	-31.81	peak

Note: 1. Measurement = Reading Level + Correct Factor.
 2. If Peak Result complies with AV limit, AV Result is deemed to comply with AV limit.
 3. Peak: Peak detector.
 4. Filter losses were only considered in the spurious frequency bands and the authorized band was not corrected for Band reject filter losses.
 5. Proper operation of the transmitter prior to adding the filter to the measurement chain.
 6. Owing to the highest peak level of unwanted emission out of the restricted bands are lower than the line(54dBuV/m) in the graph, so all the peak test point was deemed to comply with the limits -27dBm/MHz (68.2dBuV/m) list in the standard CFR 47 FCC §15.407 (b) and ISED RSS-247 6.2.

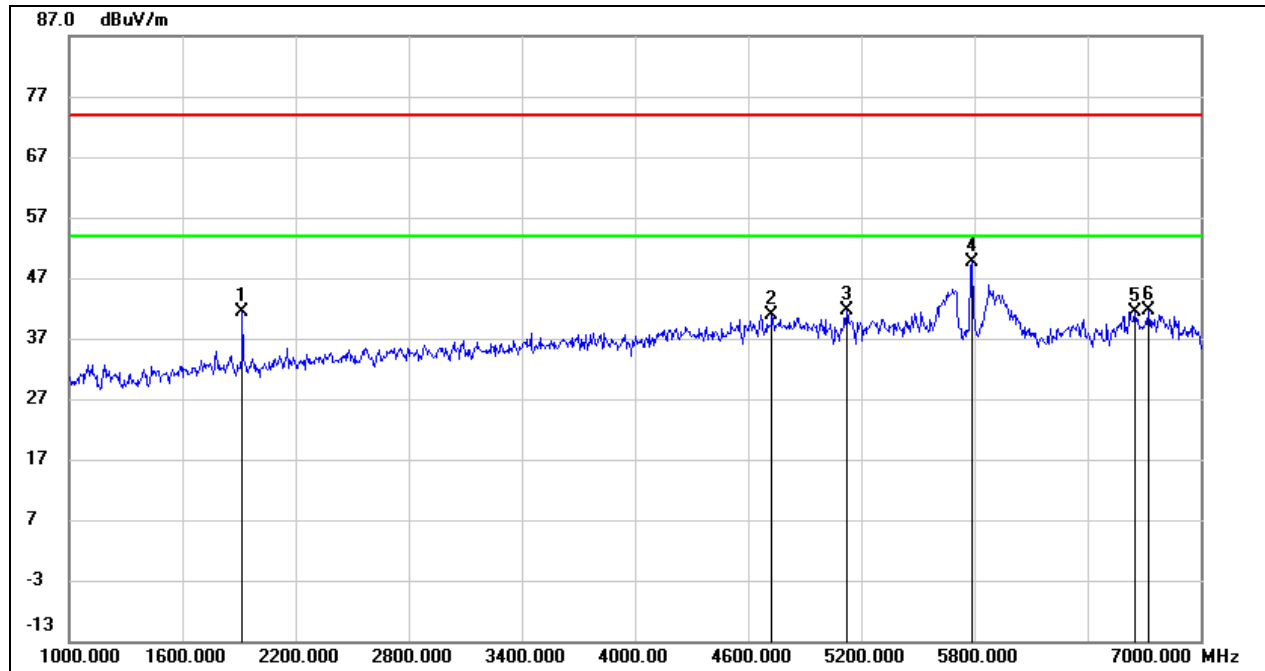
**HARMONICS AND SPURIOUS EMISSIONS (MID CHANNEL, HORIZONTAL)**

No.	Frequency (MHz)	Reading (dBuV)	Correct (dB/m)	Result (dBuV/m)	Limit (dBuV/m)	Margin (dB)	Remark
1	1920.250	51.47	-10.13	41.34	74.00	-32.66	peak
2	4728.250	40.65	0.17	40.82	74.00	-33.18	peak
3	5126.500	40.01	1.66	41.67	74.00	-32.33	peak
4	5788.000	47.03	2.50	49.53	74.00	-24.47	peak
5	6657.250	35.91	5.52	41.43	74.00	-32.57	peak
6	6725.500	36.04	5.55	41.59	74.00	-32.41	peak

Note: 1. Measurement = Reading Level + Correct Factor.

2. If Peak Result complies with AV limit, AV Result is deemed to comply with AV limit.

3. Peak: Peak detector.

4. Filter losses were only considered in the spurious frequency bands and the authorized band was not corrected for Band reject filter losses.

5. Proper operation of the transmitter prior to adding the filter to the measurement chain.

6. Owing to the highest peak level of unwanted emission out of the restricted bands are lower than the line(54dBuV/m) in the graph, so all the peak test point was deemed to comply with the limits -27dBm/MHz (68.2dBuV/m) list in the standard CFR 47 FCC §15.407 (b) and ISED RSS-247 6.2.



HARMONICS AND SPURIOUS EMISSIONS (MID CHANNEL, VERTICAL)

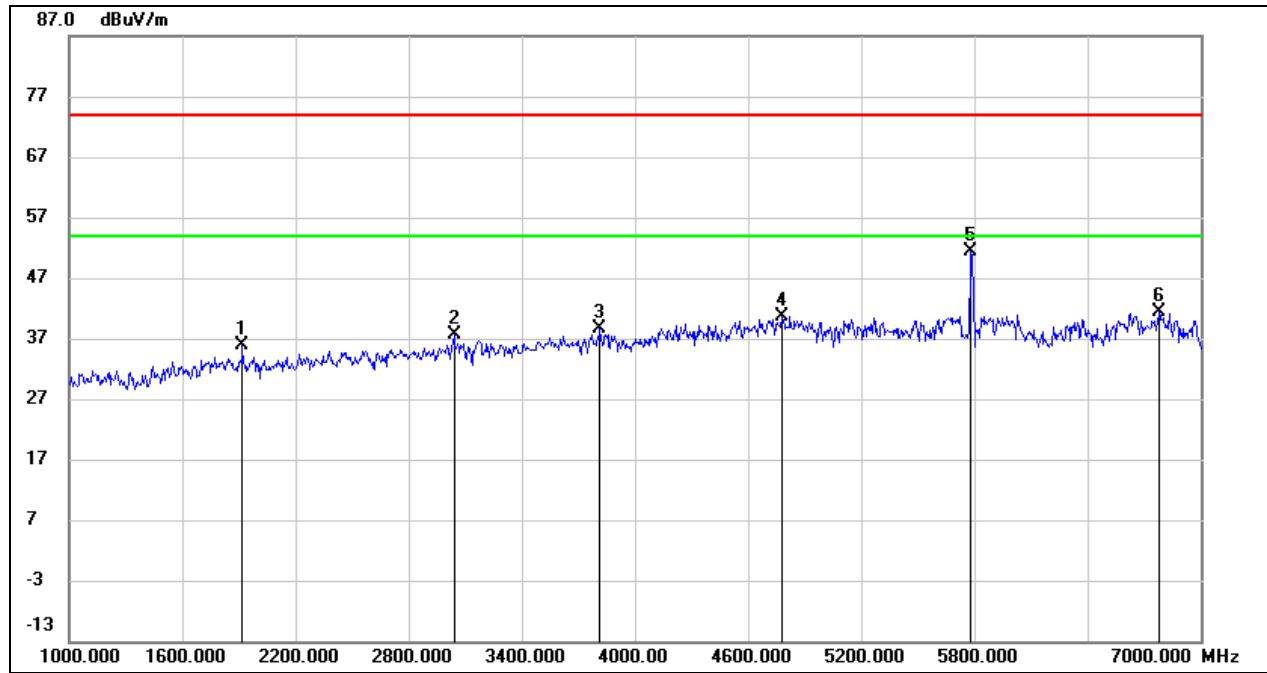

No.	Frequency (MHz)	Reading (dBuV)	Correct (dB/m)	Result (dBuV/m)	Limit (dBuV/m)	Margin (dB)	Remark
1	1920.250	45.92	-10.13	35.79	74.00	-38.21	peak
2	3043.750	43.24	-5.52	37.72	74.00	-36.28	peak
3	3819.250	42.00	-3.29	38.71	74.00	-35.29	peak
4	4782.250	40.19	0.48	40.67	74.00	-33.33	peak
5	5786.500	48.77	2.50	51.27	74.00	-22.73	peak
6	6778.000	35.83	5.56	41.39	74.00	-32.61	peak

Note: 1. Measurement = Reading Level + Correct Factor.
 2. If Peak Result complies with AV limit, AV Result is deemed to comply with AV limit.
 3. Peak: Peak detector.
 4. Filter losses were only considered in the spurious frequency bands and the authorized band was not corrected for Band reject filter losses.
 5. Proper operation of the transmitter prior to adding the filter to the measurement chain.
 6. Owing to the highest peak level of unwanted emission out of the restricted bands are lower than the line(54dBuV/m) in the graph, so all the peak test point was deemed to comply with the limits -27dBm/MHz (68.2dBuV/m) list in the standard CFR 47 FCC §15.407 (b) and ISSED RSS-247 6.2.



HARMONICS AND SPURIOUS EMISSIONS (HIGH CHANNEL, HORIZONTAL)

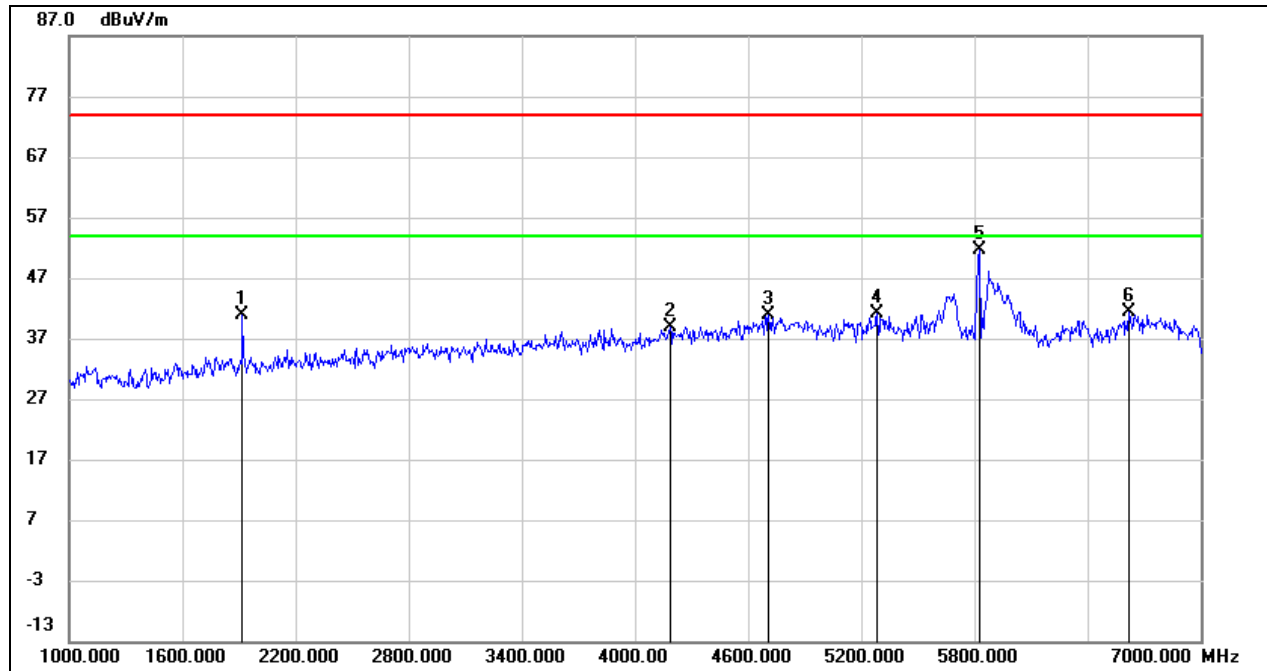

No.	Frequency (MHz)	Reading (dBuV)	Correct (dB/m)	Result (dBuV/m)	Limit (dBuV/m)	Margin (dB)	Remark
1	1920.250	51.10	-10.13	40.97	74.00	-33.03	peak
2	4187.500	40.70	-1.78	38.92	74.00	-35.08	peak
3	4712.500	40.69	0.09	40.78	74.00	-33.22	peak
4	5284.000	39.18	2.01	41.19	74.00	-32.81	peak
5	5825.000	48.92	2.61	51.53	/	/	fundamental
6	6619.750	35.77	5.51	41.28	74.00	-32.72	peak

Note: 1. Measurement = Reading Level + Correct Factor.
 2. If Peak Result complies with AV limit, AV Result is deemed to comply with AV limit.
 3. Peak: Peak detector.
 4. Filter losses were only considered in the spurious frequency bands and the authorized band was not corrected for Band reject filter losses.
 5. Proper operation of the transmitter prior to adding the filter to the measurement chain.
 6. Owing to the highest peak level of unwanted emission out of the restricted bands are lower than the line(54dBuV/m) in the graph, so all the peak test point was deemed to comply with the limits -27dBm/MHz (68.2dBuV/m) list in the standard CFR 47 FCC §15.407 (b) and ISED RSS-247 6.2.



HARMONICS AND SPURIOUS EMISSIONS (HIGH CHANNEL, VERTICAL)

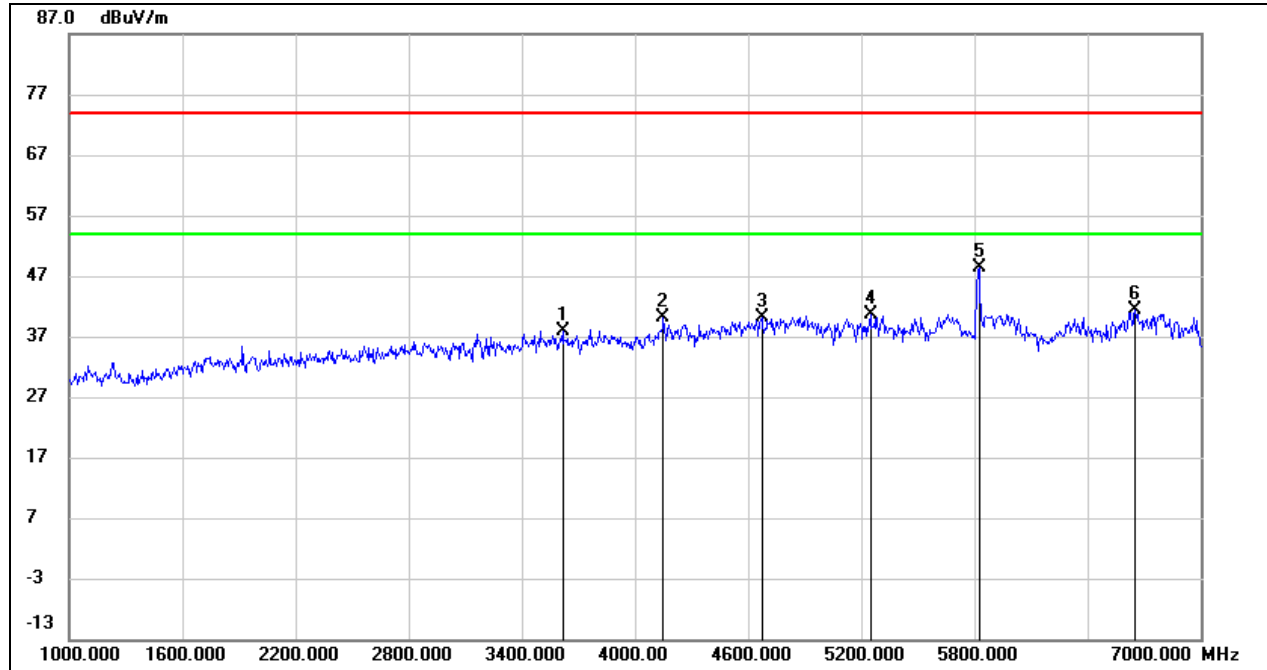

No.	Frequency (MHz)	Reading (dBuV)	Correct (dB/m)	Result (dBuV/m)	Limit (dBuV/m)	Margin (dB)	Remark
1	3619.750	41.87	-4.10	37.77	74.00	-36.23	peak
2	4153.000	42.27	-2.12	40.15	74.00	-33.85	peak
3	4673.500	40.34	-0.14	40.20	74.00	-33.80	peak
4	5248.000	38.61	2.05	40.66	74.00	-33.34	peak
5	5825.000	45.81	2.61	48.42	/	/	fundamental
6	6653.500	35.89	5.52	41.41	74.00	-32.59	peak

Note: 1. Measurement = Reading Level + Correct Factor.
 2. If Peak Result complies with AV limit, AV Result is deemed to comply with AV limit.
 3. Peak: Peak detector.
 4. Filter losses were only considered in the spurious frequency bands and the authorized band was not corrected for Band reject filter losses.
 5. Proper operation of the transmitter prior to adding the filter to the measurement chain.
 6. Owing to the highest peak level of unwanted emission out of the restricted bands are lower than the line(54dBuV/m) in the graph, so all the peak test point was deemed to comply with the limits -27dBm/MHz (68.2dBuV/m) list in the standard CFR 47 FCC §15.407 (b) and ISED RSS-247 6.2.

Note: All the modes, bands and antennas had been tested, but only the worst data was recorded in the report.



8.3. SPURIOUS EMISSIONS (7 GHz ~ 18 GHz)

8.3.1. 802.11a SISO MODE

UNII-1 BAND

ANTENNA 1 TEST RESULTS (WORST CASE)

HARMONICS AND SPURIOUS EMISSIONS (LOW CHANNEL, HORIZONTAL)

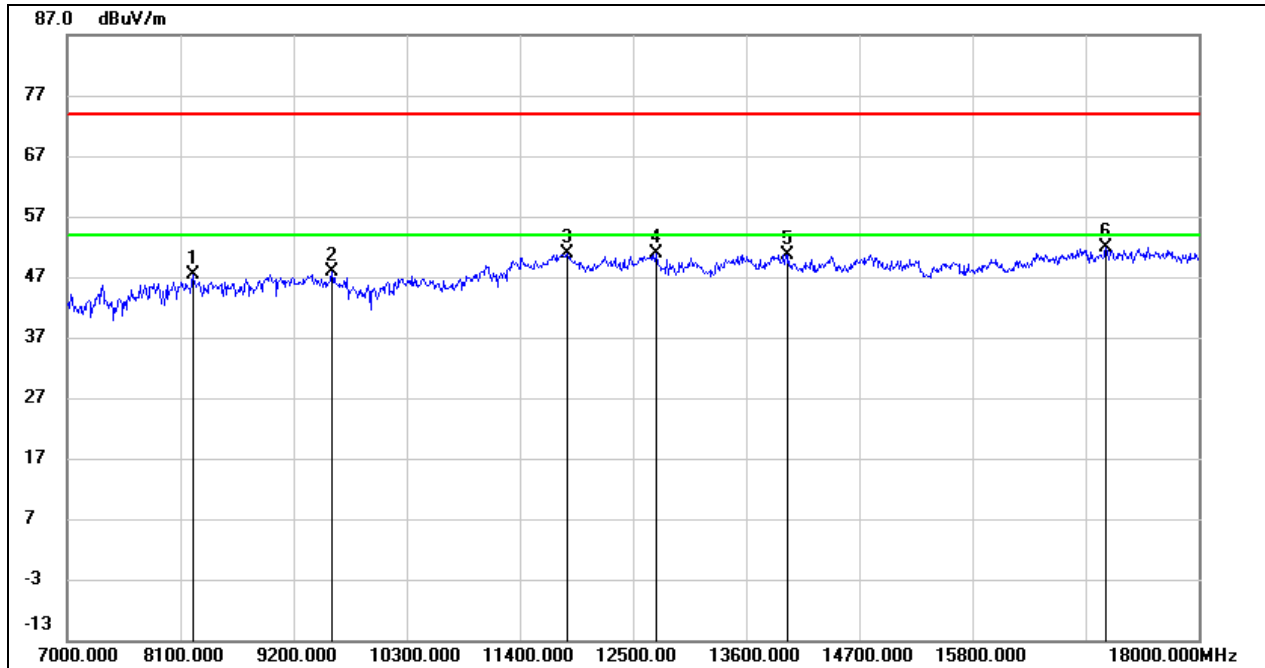

No.	Frequency (MHz)	Reading (dBuV)	Correct (dB/m)	Result (dBuV/m)	Limit (dBuV/m)	Margin (dB)	Remark
1	8221.000	37.99	9.28	47.27	74.00	-26.73	peak
2	9574.000	37.41	10.46	47.87	74.00	-26.13	peak
3	11862.000	35.39	15.52	50.91	74.00	-23.09	peak
4	12731.000	35.45	15.53	50.98	74.00	-23.02	peak
5	14007.000	33.89	16.85	50.74	74.00	-23.26	peak
6	17098.000	31.29	20.63	51.92	74.00	-22.08	peak

Note: 1. Measurement = Reading Level + Correct Factor.

2. If Peak Result complies with AV limit, AV Result is deemed to comply with AV limit.

3. Peak: Peak detector.

4. Filter losses were only considered in the spurious frequency bands and the authorized band was not corrected for High Pass Filter losses.

5. Proper operation of the transmitter prior to adding the filter to the measurement chain.

6. Owing to the highest peak level of unwanted emission out of the restricted bands are lower than the line(54dBuV/m) in the graph, so all the peak test point was deemed to comply with the limits -27dBm/MHz (68.2dBuV/m) list in the standard CFR 47 FCC §15.407 (b) and ISSED RSS-247 6.2.



HARMONICS AND SPURIOUS EMISSIONS (LOW CHANNEL, VERTICAL)

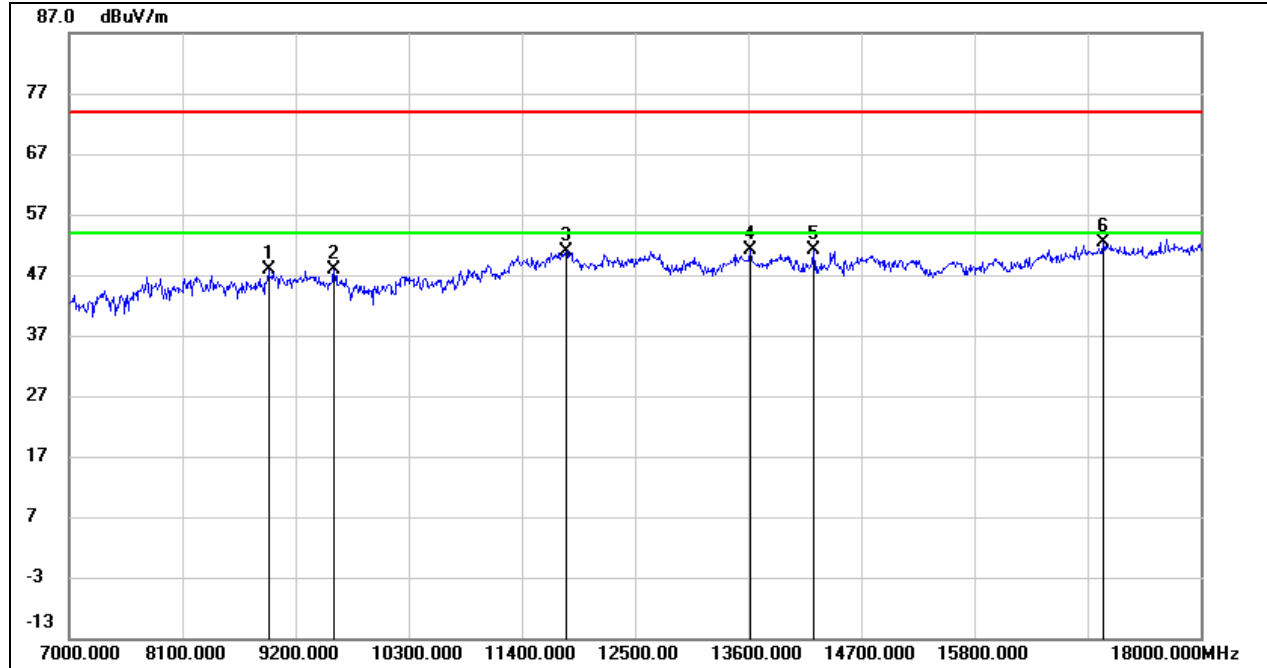

No.	Frequency (MHz)	Reading (dBuV)	Correct (dB/m)	Result (dBuV/m)	Limit (dBuV/m)	Margin (dB)	Remark
1	8936.000	37.90	9.96	47.86	74.00	-26.14	peak
2	9574.000	37.41	10.46	47.87	74.00	-26.13	peak
3	11829.000	35.43	15.57	51.00	74.00	-23.00	peak
4	13622.000	34.54	16.48	51.02	74.00	-22.98	peak
5	14238.000	34.30	16.74	51.04	74.00	-22.96	peak
6	17054.000	32.01	20.45	52.46	74.00	-21.54	peak

Note: 1. Measurement = Reading Level + Correct Factor.
 2. If Peak Result complies with AV limit, AV Result is deemed to comply with AV limit.
 3. Peak: Peak detector.
 4. Filter losses were only considered in the spurious frequency bands and the authorized band was not corrected for High Pass Filter losses.
 5. Proper operation of the transmitter prior to adding the filter to the measurement chain.
 6. Owing to the highest peak level of unwanted emission out of the restricted bands are lower than the line(54dBuV/m) in the graph, so all the peak test point was deemed to comply with the limits -27dBm/MHz (68.2dBuV/m) list in the standard CFR 47 FCC §15.407 (b) and ISED RSS-247 6.2.

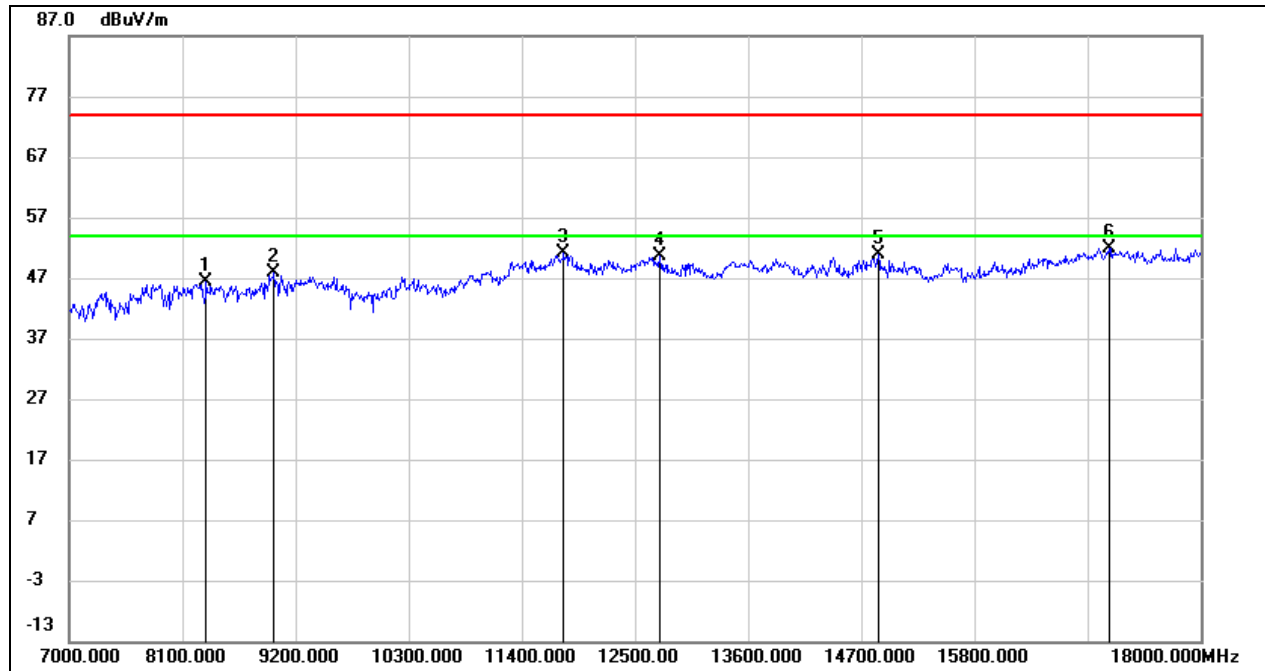
**HARMONICS AND SPURIOUS EMISSIONS (MID CHANNEL, HORIZONTAL)**

No.	Frequency (MHz)	Reading (dBuV)	Correct (dB/m)	Result (dBuV/m)	Limit (dBuV/m)	Margin (dB)	Remark
1	8331.000	37.55	8.85	46.40	74.00	-27.60	peak
2	8991.000	37.31	10.53	47.84	74.00	-26.16	peak
3	11807.000	35.56	15.61	51.17	74.00	-22.83	peak
4	12742.000	35.13	15.54	50.67	74.00	-23.33	peak
5	14865.000	33.97	16.83	50.80	74.00	-23.20	peak
6	17109.000	31.33	20.67	52.00	74.00	-22.00	peak

Note: 1. Measurement = Reading Level + Correct Factor.

2. If Peak Result complies with AV limit, AV Result is deemed to comply with AV limit.

3. Peak: Peak detector.

4. Filter losses were only considered in the spurious frequency bands and the authorized band was not corrected for High Pass Filter losses.

5. Proper operation of the transmitter prior to adding the filter to the measurement chain.

6. Owing to the highest peak level of unwanted emission out of the restricted bands are lower than the line(54dBuV/m) in the graph, so all the peak test point was deemed to comply with the limits -27dBm/MHz (68.2dBuV/m) list in the standard CFR 47 FCC §15.407 (b) and ISSED RSS-247 6.2.



HARMONICS AND SPURIOUS EMISSIONS (MID CHANNEL, VERTICAL)

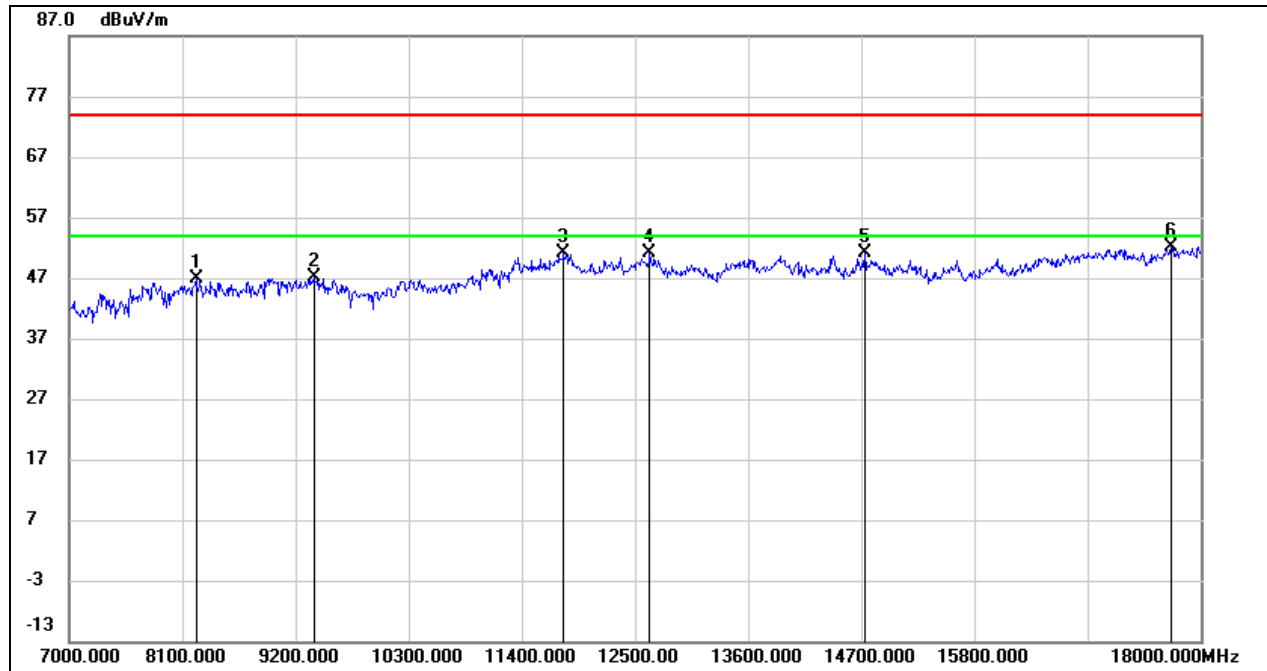

No.	Frequency (MHz)	Reading (dBuV)	Correct (dB/m)	Result (dBuV/m)	Limit (dBuV/m)	Margin (dB)	Remark
1	8232.000	37.76	9.23	46.99	74.00	-27.01	peak
2	9376.000	36.95	10.19	47.14	74.00	-26.86	peak
3	11807.000	35.56	15.61	51.17	74.00	-22.83	peak
4	12643.000	35.86	15.36	51.22	74.00	-22.78	peak
5	14733.000	34.48	16.69	51.17	74.00	-22.83	peak
6	17714.000	30.09	22.04	52.13	74.00	-21.87	peak

Note: 1. Measurement = Reading Level + Correct Factor.
 2. If Peak Result complies with AV limit, AV Result is deemed to comply with AV limit.
 3. Peak: Peak detector.
 4. Filter losses were only considered in the spurious frequency bands and the authorized band was not corrected for High Pass Filter losses.
 5. Proper operation of the transmitter prior to adding the filter to the measurement chain.
 6. Owing to the highest peak level of unwanted emission out of the restricted bands are lower than the line(54dBuV/m) in the graph, so all the peak test point was deemed to comply with the limits -27dBm/MHz (68.2dBuV/m) list in the standard CFR 47 FCC §15.407 (b) and ISED RSS-247 6.2.

HARMONICS AND SPURIOUS EMISSIONS (HIGH CHANNEL, HORIZONTAL)

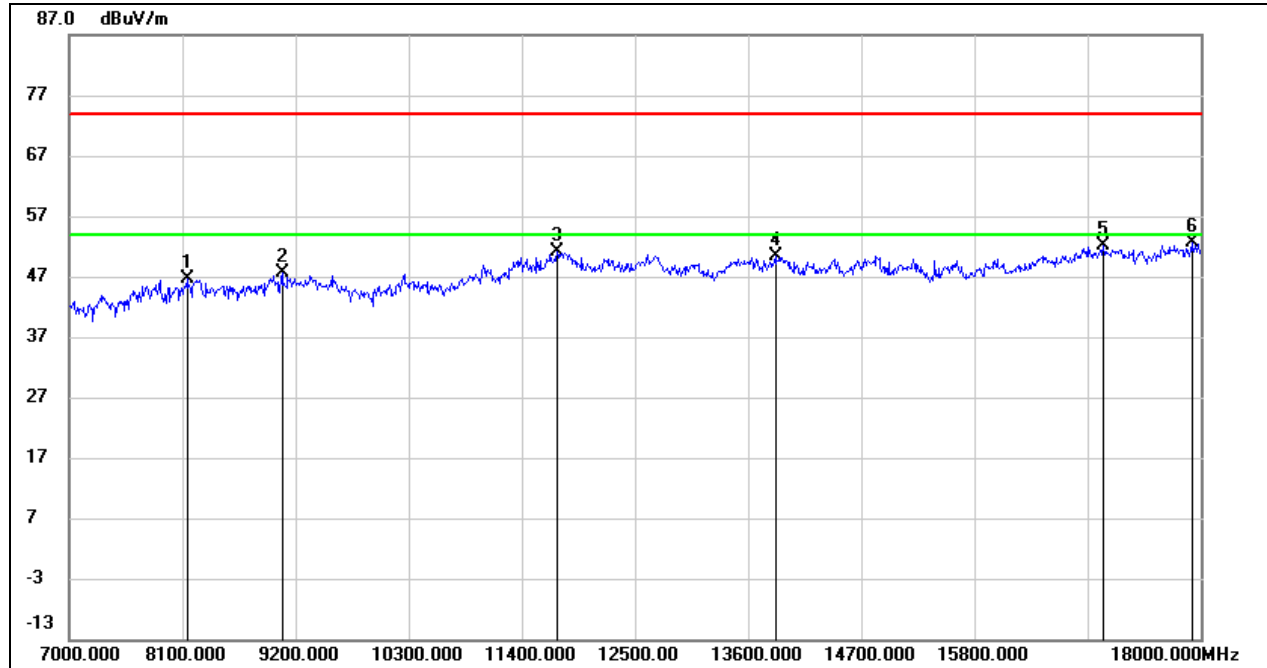

No.	Frequency (MHz)	Reading (dBuV)	Correct (dB/m)	Result (dBuV/m)	Limit (dBuV/m)	Margin (dB)	Remark
1	8144.000	37.86	8.88	46.74	74.00	-27.26	peak
2	9068.000	37.35	10.17	47.52	74.00	-26.48	peak
3	11741.000	35.89	15.28	51.17	74.00	-22.83	peak
4	13864.000	33.44	16.92	50.36	74.00	-23.64	peak
5	17054.000	31.59	20.45	52.04	74.00	-21.96	peak
6	17912.000	29.95	22.69	52.64	74.00	-21.36	peak

Note: 1. Measurement = Reading Level + Correct Factor.
 2. If Peak Result complies with AV limit, AV Result is deemed to comply with AV limit.
 3. Peak: Peak detector.
 4. Filter losses were only considered in the spurious frequency bands and the authorized band was not corrected for High Pass Filter losses.
 5. Proper operation of the transmitter prior to adding the filter to the measurement chain.
 6. Owing to the highest peak level of unwanted emission out of the restricted bands are lower than the line(54dBuV/m) in the graph, so all the peak test point was deemed to comply with the limits -27dBm/MHz (68.2dBuV/m) list in the standard CFR 47 FCC §15.407 (b) and ISED RSS-247 6.2.



HARMONICS AND SPURIOUS EMISSIONS (HIGH CHANNEL, VERTICAL)

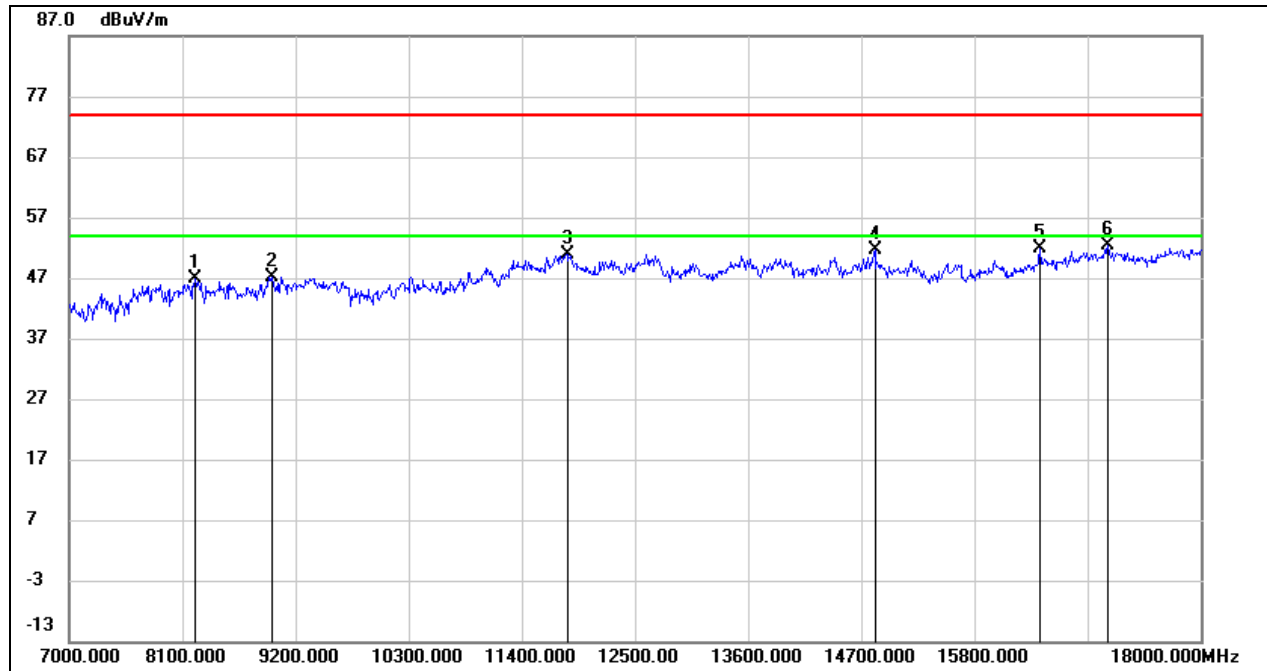

No.	Frequency (MHz)	Reading (dBuV)	Correct (dB/m)	Result (dBuV/m)	Limit (dBuV/m)	Margin (dB)	Remark
1	8221.000	37.57	9.28	46.85	74.00	-27.15	peak
2	8969.000	36.90	10.31	47.21	74.00	-26.79	peak
3	11840.000	35.44	15.56	51.00	74.00	-23.00	peak
4	14832.000	34.75	16.82	51.57	74.00	-22.43	peak
5	16438.000	33.04	18.86	51.90	74.00	-22.10	peak
6	17098.000	31.65	20.63	52.28	74.00	-21.72	peak

Note: 1. Measurement = Reading Level + Correct Factor.
 2. If Peak Result complies with AV limit, AV Result is deemed to comply with AV limit.
 3. Peak: Peak detector.
 4. Filter losses were only considered in the spurious frequency bands and the authorized band was not corrected for High Pass Filter losses.
 5. Proper operation of the transmitter prior to adding the filter to the measurement chain.
 6. Owing to the highest peak level of unwanted emission out of the restricted bands are lower than the line(54dBuV/m) in the graph, so all the peak test point was deemed to comply with the limits -27dBm/MHz (68.2dBuV/m) list in the standard CFR 47 FCC §15.407 (b) and ISSED RSS-247 6.2.



UNII-2A BAND

ANTENNA 1 TEST RESULTS (WORST CASE)

HARMONICS AND SPURIOUS EMISSIONS (LOW CHANNEL, HORIZONTAL)

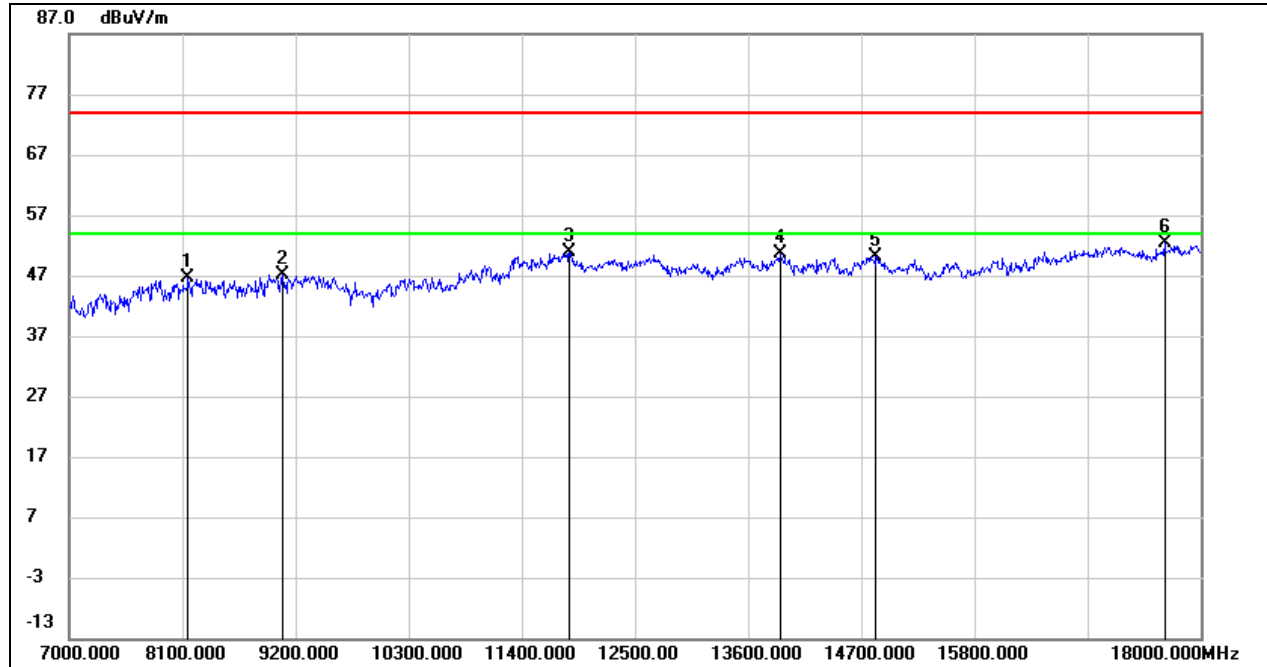

No.	Frequency (MHz)	Reading (dBuV)	Correct (dB/m)	Result (dBuV/m)	Limit (dBuV/m)	Margin (dB)	Remark
1	8155.000	37.62	8.98	46.60	74.00	-27.40	peak
2	9079.000	37.05	10.10	47.15	74.00	-26.85	peak
3	11862.000	35.44	15.52	50.96	74.00	-23.04	peak
4	13908.000	33.75	16.90	50.65	74.00	-23.35	peak
5	14843.000	33.25	16.82	50.07	74.00	-23.93	peak
6	17648.000	30.74	21.54	52.28	74.00	-21.72	peak

Note: 1. Measurement = Reading Level + Correct Factor.
 2. If Peak Result complies with AV limit, AV Result is deemed to comply with AV limit.
 3. Peak: Peak detector.
 4. Filter losses were only considered in the spurious frequency bands and the authorized band was not corrected for High Pass Filter losses.
 5. Proper operation of the transmitter prior to adding the filter to the measurement chain.
 6. Owing to the highest peak level of unwanted emission out of the restricted bands are lower than the line(54dBuV/m) in the graph, so all the peak test point was deemed to comply with the limits -27dBm/MHz (68.2dBuV/m) list in the standard CFR 47 FCC §15.407 (b) and ISSED RSS-247 6.2.

HARMONICS AND SPURIOUS EMISSIONS (LOW CHANNEL, VERTICAL)

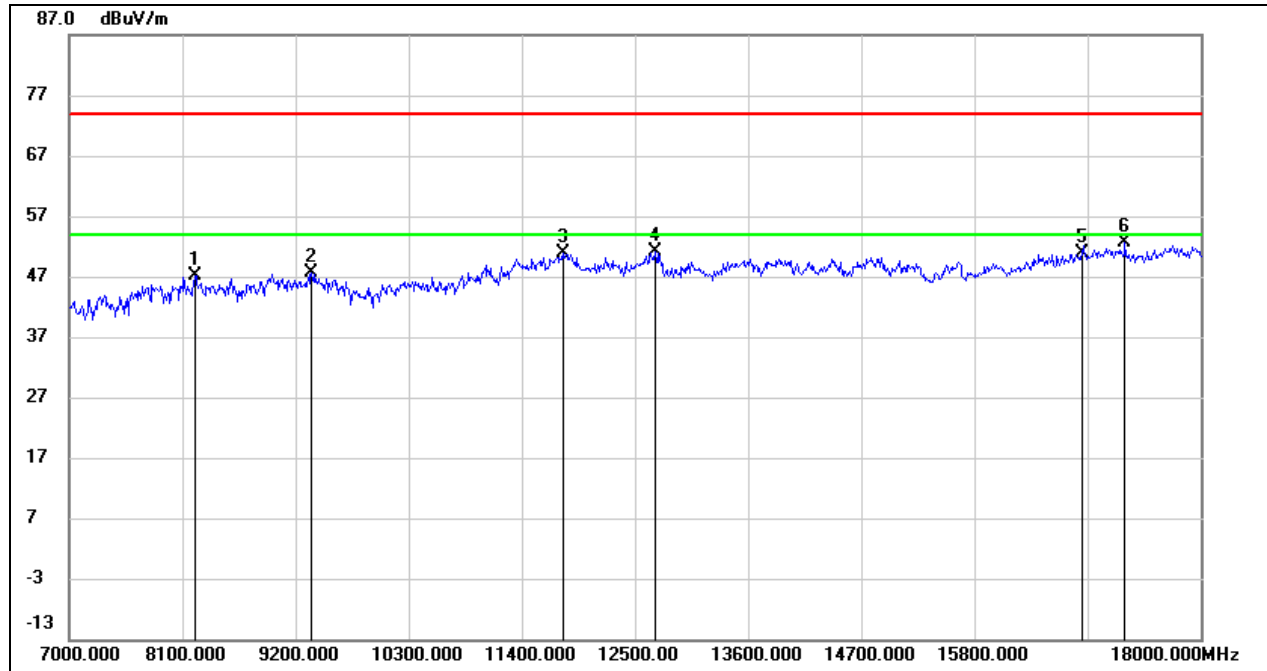

No.	Frequency (MHz)	Reading (dBuV)	Correct (dB/m)	Result (dBuV/m)	Limit (dBuV/m)	Margin (dB)	Remark
1	8221.000	37.91	9.28	47.19	74.00	-26.81	peak
2	9354.000	37.47	10.07	47.54	74.00	-26.46	peak
3	11796.000	35.20	15.59	50.79	74.00	-23.21	peak
4	12698.000	35.69	15.47	51.16	74.00	-22.84	peak
5	16845.000	31.06	19.85	50.91	74.00	-23.09	peak
6	17263.000	31.78	20.95	52.73	74.00	-21.27	peak

Note: 1. Measurement = Reading Level + Correct Factor.
 2. If Peak Result complies with AV limit, AV Result is deemed to comply with AV limit.
 3. Peak: Peak detector.
 4. Filter losses were only considered in the spurious frequency bands and the authorized band was not corrected for High Pass Filter losses.
 5. Proper operation of the transmitter prior to adding the filter to the measurement chain.
 6. Owing to the highest peak level of unwanted emission out of the restricted bands are lower than the line(54dBuV/m) in the graph, so all the peak test point was deemed to comply with the limits -27dBm/MHz (68.2dBuV/m) list in the standard CFR 47 FCC §15.407 (b) and ISED RSS-247 6.2.



HARMONICS AND SPURIOUS EMISSIONS (MID CHANNEL, HORIZONTAL)

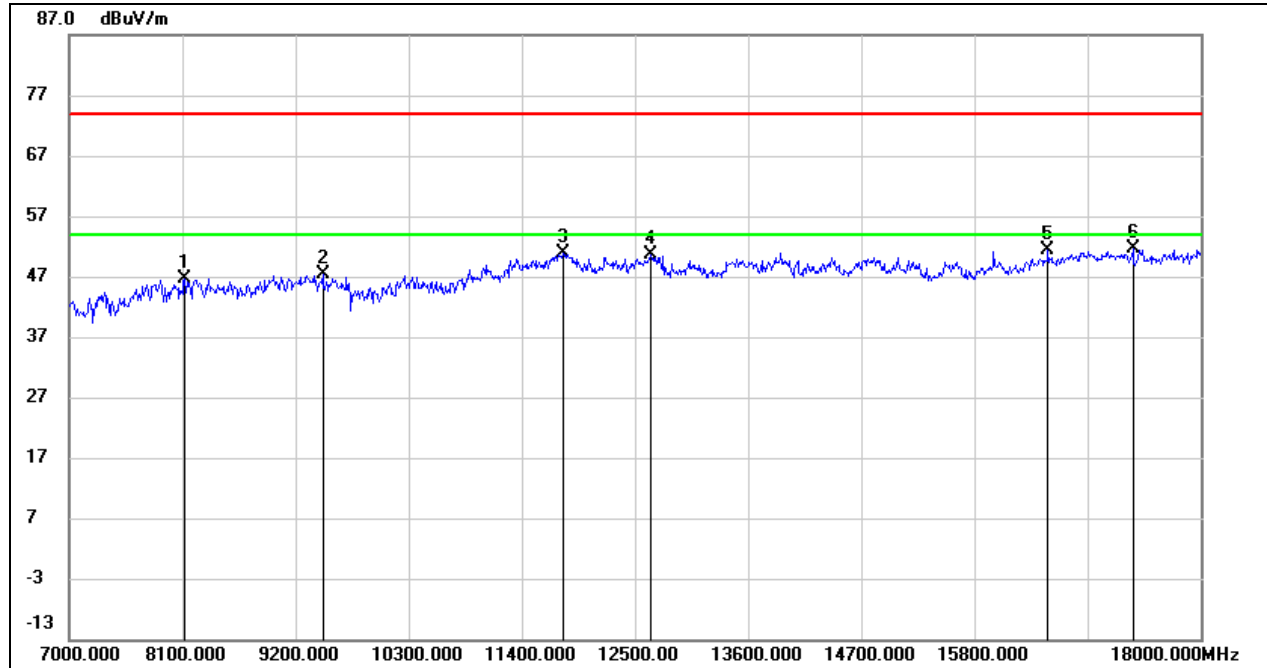

No.	Frequency (MHz)	Reading (dBuV)	Correct (dB/m)	Result (dBuV/m)	Limit (dBuV/m)	Margin (dB)	Remark
1	8122.000	37.92	8.70	46.62	74.00	-27.38	peak
2	9464.000	36.90	10.40	47.30	74.00	-26.70	peak
3	11807.000	35.34	15.61	50.95	74.00	-23.05	peak
4	12654.000	35.29	15.38	50.67	74.00	-23.33	peak
5	16515.000	32.08	19.19	51.27	74.00	-22.73	peak
6	17340.000	30.90	20.82	51.72	74.00	-22.28	peak

Note: 1. Measurement = Reading Level + Correct Factor.
 2. If Peak Result complies with AV limit, AV Result is deemed to comply with AV limit.
 3. Peak: Peak detector.
 4. Filter losses were only considered in the spurious frequency bands and the authorized band was not corrected for High Pass Filter losses.
 5. Proper operation of the transmitter prior to adding the filter to the measurement chain.
 6. Owing to the highest peak level of unwanted emission out of the restricted bands are lower than the line(54dBuV/m) in the graph, so all the peak test point was deemed to comply with the limits -27dBm/MHz (68.2dBuV/m) list in the standard CFR 47 FCC §15.407 (b) and ISED RSS-247 6.2.



HARMONICS AND SPURIOUS EMISSIONS (MID CHANNEL, VERTICAL)

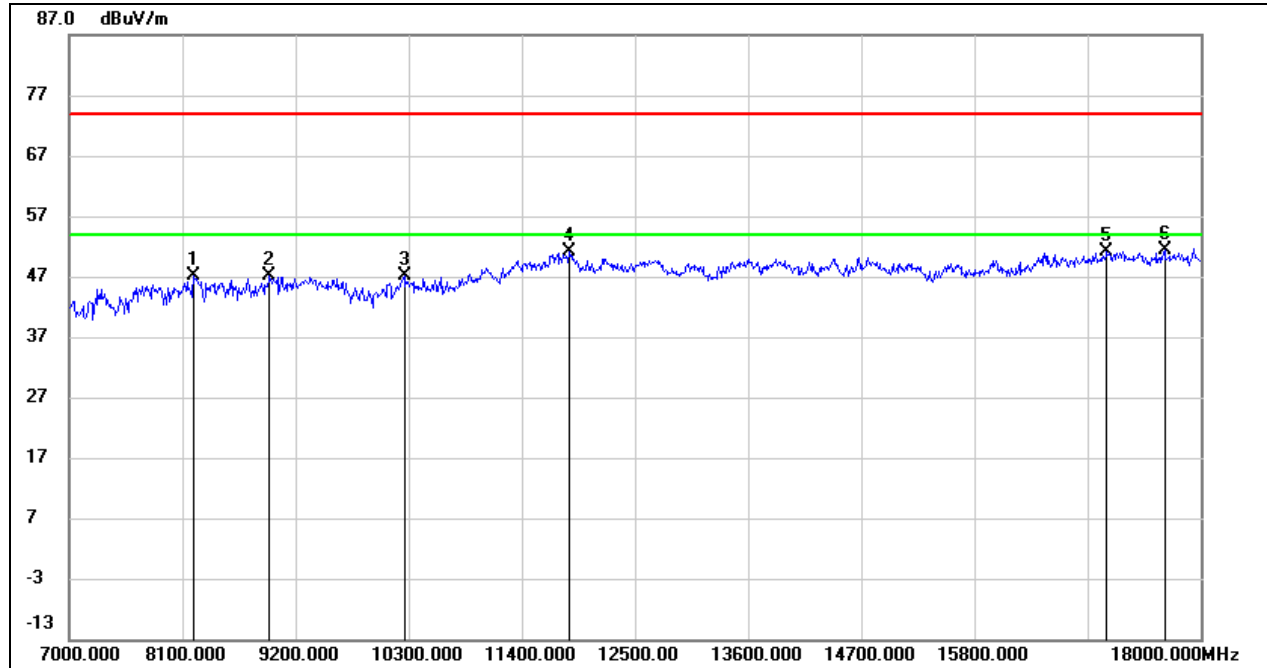

No.	Frequency (MHz)	Reading (dBuV)	Correct (dB/m)	Result (dBuV/m)	Limit (dBuV/m)	Margin (dB)	Remark
1	8210.000	37.71	9.32	47.03	74.00	-26.97	peak
2	8947.000	37.11	10.07	47.18	74.00	-26.82	peak
3	10256.000	36.11	10.94	47.05	74.00	-26.95	peak
4	11862.000	35.68	15.52	51.20	74.00	-22.80	peak
5	17087.000	30.44	20.58	51.02	74.00	-22.98	peak
6	17648.000	29.78	21.54	51.32	74.00	-22.68	peak

Note: 1. Measurement = Reading Level + Correct Factor.
 2. If Peak Result complies with AV limit, AV Result is deemed to comply with AV limit.
 3. Peak: Peak detector.
 4. Filter losses were only considered in the spurious frequency bands and the authorized band was not corrected for High Pass Filter losses.
 5. Proper operation of the transmitter prior to adding the filter to the measurement chain.
 6. Owing to the highest peak level of unwanted emission out of the restricted bands are lower than the line(54dBuV/m) in the graph, so all the peak test point was deemed to comply with the limits -27dBm/MHz (68.2dBuV/m) list in the standard CFR 47 FCC §15.407 (b) and ISED RSS-247 6.2.

HARMONICS AND SPURIOUS EMISSIONS (HIGH CHANNEL, HORIZONTAL)

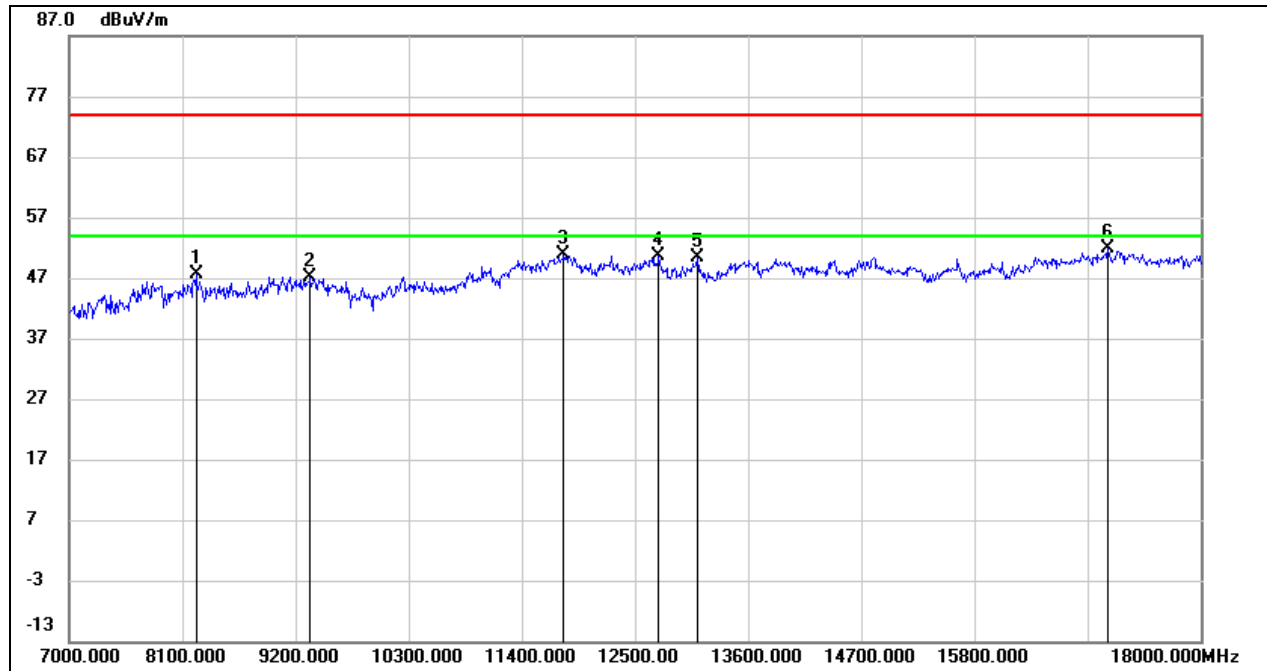

No.	Frequency (MHz)	Reading (dBuV)	Correct (dB/m)	Result (dBuV/m)	Limit (dBuV/m)	Margin (dB)	Remark
1	8232.000	38.52	9.23	47.75	74.00	-26.25	peak
2	9343.000	37.06	10.02	47.08	74.00	-26.92	peak
3	11807.000	35.33	15.61	50.94	74.00	-23.06	peak
4	12731.000	35.00	15.53	50.53	74.00	-23.47	peak
5	13105.000	34.89	15.54	50.43	74.00	-23.57	peak
6	17098.000	31.19	20.63	51.82	74.00	-22.18	peak

Note: 1. Measurement = Reading Level + Correct Factor.
 2. If Peak Result complies with AV limit, AV Result is deemed to comply with AV limit.
 3. Peak: Peak detector.
 4. Filter losses were only considered in the spurious frequency bands and the authorized band was not corrected for High Pass Filter losses.
 5. Proper operation of the transmitter prior to adding the filter to the measurement chain.
 6. Owing to the highest peak level of unwanted emission out of the restricted bands are lower than the line(54dBuV/m) in the graph, so all the peak test point was deemed to comply with the limits -27dBm/MHz (68.2dBuV/m) list in the standard CFR 47 FCC §15.407 (b) and ISED RSS-247 6.2.

HARMONICS AND SPURIOUS EMISSIONS (HIGH CHANNEL, VERTICAL)

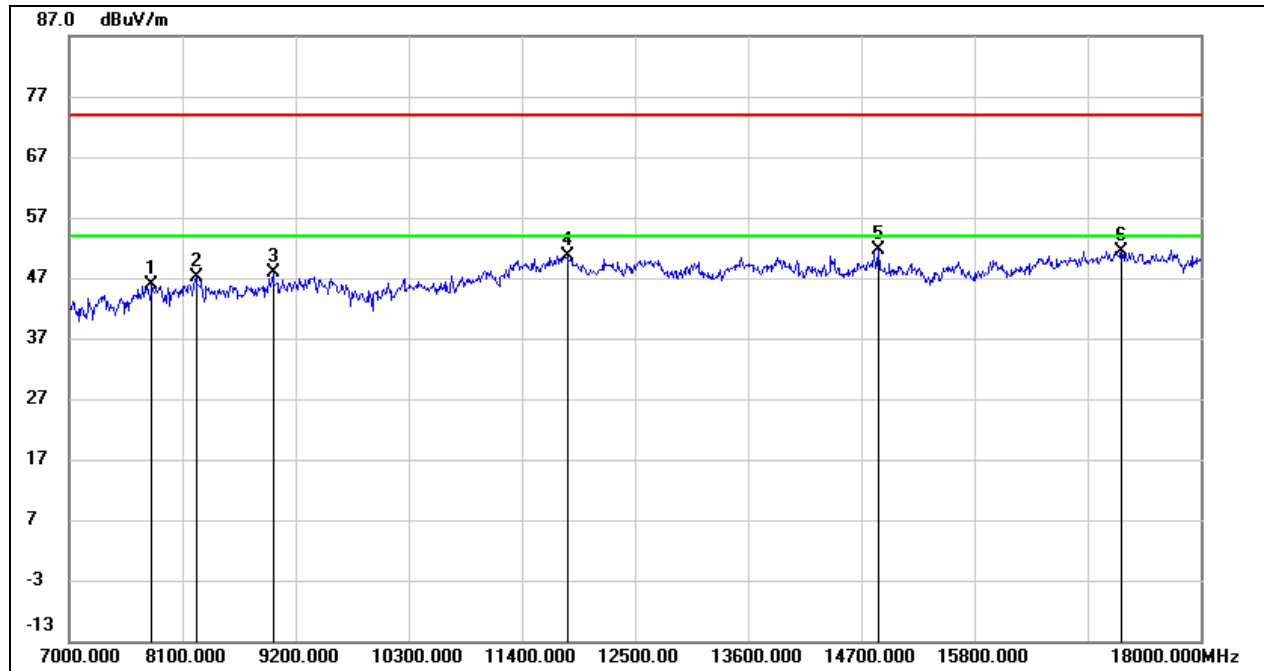

No.	Frequency (MHz)	Reading (dBuV)	Correct (dB/m)	Result (dBuV/m)	Limit (dBuV/m)	Margin (dB)	Remark
1	7803.000	37.68	8.24	45.92	74.00	-28.08	peak
2	8232.000	38.02	9.23	47.25	74.00	-26.75	peak
3	8980.000	37.55	10.41	47.96	74.00	-26.04	peak
4	11840.000	35.14	15.56	50.70	74.00	-23.30	peak
5	14865.000	34.91	16.83	51.74	74.00	-22.26	peak
6	17230.000	30.51	20.99	51.50	74.00	-22.50	peak

Note: 1. Measurement = Reading Level + Correct Factor.
 2. If Peak Result complies with AV limit, AV Result is deemed to comply with AV limit.
 3. Peak: Peak detector.
 4. Filter losses were only considered in the spurious frequency bands and the authorized band was not corrected for High Pass Filter losses.
 5. Proper operation of the transmitter prior to adding the filter to the measurement chain.
 6. Owing to the highest peak level of unwanted emission out of the restricted bands are lower than the line(54dBuV/m) in the graph, so all the peak test point was deemed to comply with the limits -27dBm/MHz (68.2dBuV/m) list in the standard CFR 47 FCC §15.407 (b) and ISED RSS-247 6.2.



UNII-2C BAND

ANTENNA 1 TEST RESULTS (WORST CASE)

HARMONICS AND SPURIOUS EMISSIONS (LOW CHANNEL, HORIZONTAL)

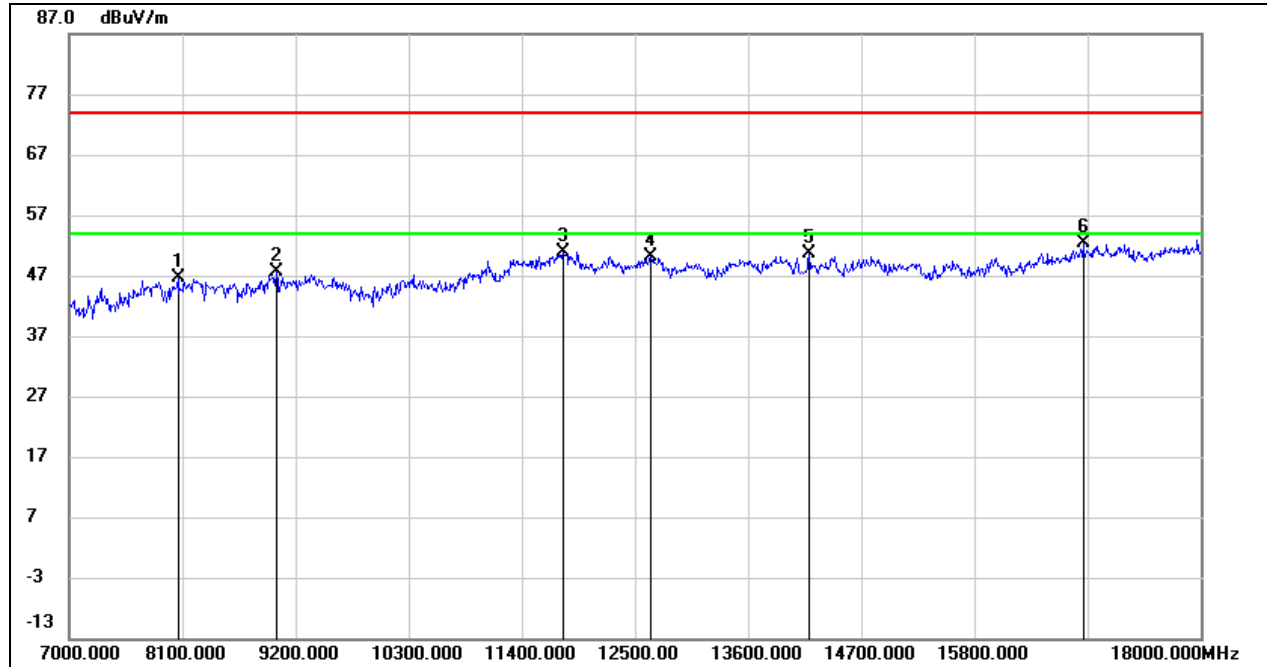

No.	Frequency (MHz)	Reading (dBuV)	Correct (dB/m)	Result (dBuV/m)	Limit (dBuV/m)	Margin (dB)	Remark
1	8056.000	38.44	8.14	46.58	74.00	-27.42	peak
2	9013.000	37.02	10.54	47.56	74.00	-26.44	peak
3	11807.000	35.34	15.61	50.95	74.00	-23.05	peak
4	12654.000	34.68	15.38	50.06	74.00	-23.94	peak
5	14194.000	33.90	16.71	50.61	74.00	-23.39	peak
6	16856.000	32.53	19.87	52.40	74.00	-21.60	peak

Note: 1. Measurement = Reading Level + Correct Factor.
 2. If Peak Result complies with AV limit, AV Result is deemed to comply with AV limit.
 3. Peak: Peak detector.
 4. Filter losses were only considered in the spurious frequency bands and the authorized band was not corrected for High Pass Filter losses.
 5. Proper operation of the transmitter prior to adding the filter to the measurement chain.
 6. Owing to the highest peak level of unwanted emission out of the restricted bands are lower than the line(54dBuV/m) in the graph, so all the peak test point was deemed to comply with the limits -27dBm/MHz (68.2dBuV/m) list in the standard CFR 47 FCC §15.407 (b) and ISSED RSS-247 6.2.

HARMONICS AND SPURIOUS EMISSIONS (LOW CHANNEL, VERTICAL)

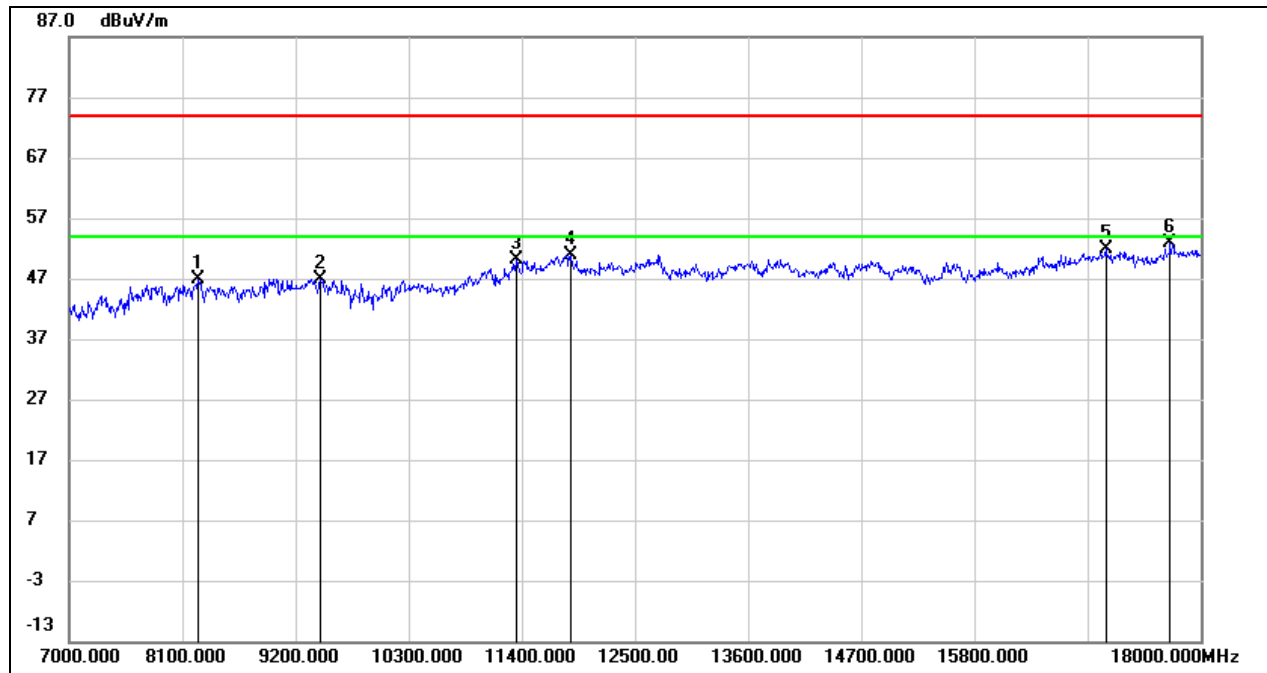

No.	Frequency (MHz)	Reading (dBuV)	Correct (dB/m)	Result (dBuV/m)	Limit (dBuV/m)	Margin (dB)	Remark
1	8254.000	37.78	9.15	46.93	74.00	-27.07	peak
2	9442.000	36.51	10.37	46.88	74.00	-27.12	peak
3	11345.000	36.14	14.06	50.20	74.00	-23.80	peak
4	11873.000	35.49	15.50	50.99	74.00	-23.01	peak
5	17076.000	31.37	20.54	51.91	74.00	-22.09	peak
6	17703.000	31.00	21.96	52.96	74.00	-21.04	peak

Note: 1. Measurement = Reading Level + Correct Factor.
 2. If Peak Result complies with AV limit, AV Result is deemed to comply with AV limit.
 3. Peak: Peak detector.
 4. Filter losses were only considered in the spurious frequency bands and the authorized band was not corrected for High Pass Filter losses.
 5. Proper operation of the transmitter prior to adding the filter to the measurement chain.
 6. Owing to the highest peak level of unwanted emission out of the restricted bands are lower than the line(54dBuV/m) in the graph, so all the peak test point was deemed to comply with the limits -27dBm/MHz (68.2dBuV/m) list in the standard CFR 47 FCC §15.407 (b) and ISED RSS-247 6.2.



HARMONICS AND SPURIOUS EMISSIONS (MID CHANNEL, HORIZONTAL)

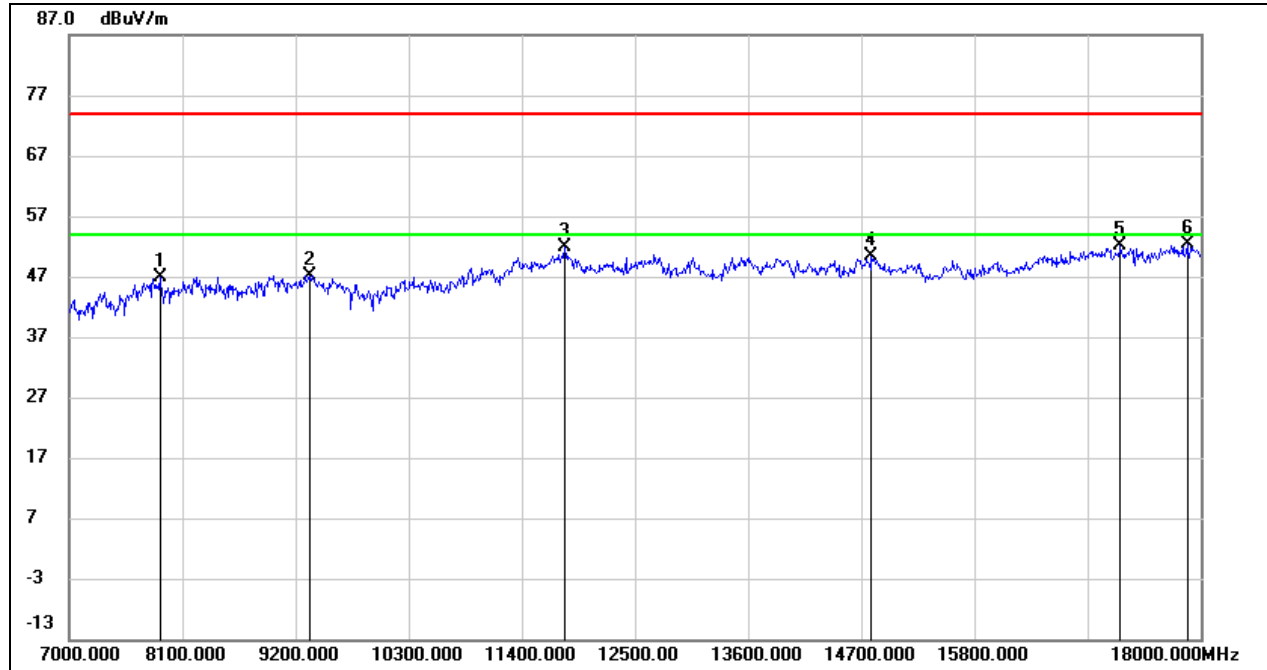

No.	Frequency (MHz)	Reading (dBuV)	Correct (dB/m)	Result (dBuV/m)	Limit (dBuV/m)	Margin (dB)	Remark
1	7880.000	38.88	8.01	46.89	74.00	-27.11	peak
2	9332.000	37.22	9.97	47.19	74.00	-26.81	peak
3	11818.000	36.23	15.58	51.81	74.00	-22.19	peak
4	14799.000	33.65	16.80	50.45	74.00	-23.55	peak
5	17219.000	31.15	21.01	52.16	74.00	-21.84	peak
6	17868.000	29.67	22.71	52.38	74.00	-21.62	peak

Note: 1. Measurement = Reading Level + Correct Factor.
 2. If Peak Result complies with AV limit, AV Result is deemed to comply with AV limit.
 3. Peak: Peak detector.
 4. Filter losses were only considered in the spurious frequency bands and the authorized band was not corrected for High Pass Filter losses.
 5. Proper operation of the transmitter prior to adding the filter to the measurement chain.
 6. Owing to the highest peak level of unwanted emission out of the restricted bands are lower than the line(54dBuV/m) in the graph, so all the peak test point was deemed to comply with the limits -27dBm/MHz (68.2dBuV/m) list in the standard CFR 47 FCC §15.407 (b) and ISED RSS-247 6.2.



HARMONICS AND SPURIOUS EMISSIONS (MID CHANNEL, VERTICAL)

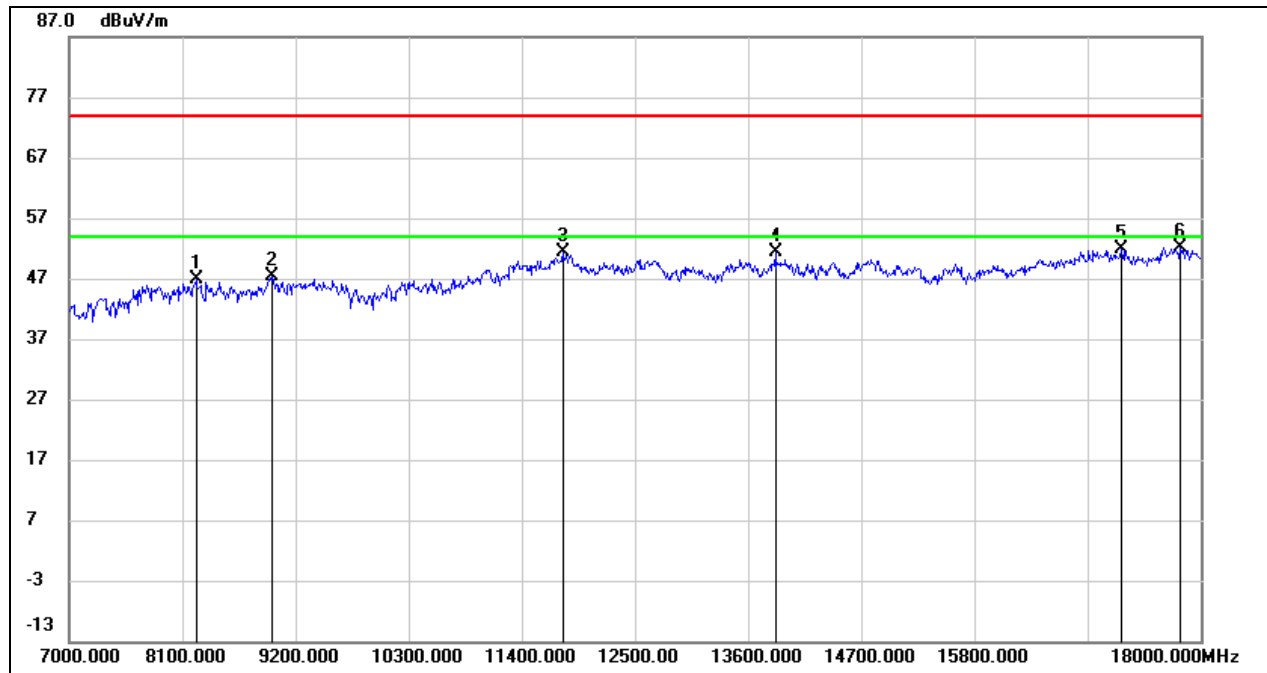

No.	Frequency (MHz)	Reading (dBuV)	Correct (dB/m)	Result (dBuV/m)	Limit (dBuV/m)	Margin (dB)	Remark
1	8232.000	37.67	9.23	46.90	74.00	-27.10	peak
2	8969.000	36.96	10.31	47.27	74.00	-26.73	peak
3	11796.000	35.71	15.59	51.30	74.00	-22.70	peak
4	13864.000	34.39	16.92	51.31	74.00	-22.69	peak
5	17230.000	30.93	20.99	51.92	74.00	-22.08	peak
6	17802.000	29.50	22.72	52.22	74.00	-21.78	peak

Note: 1. Measurement = Reading Level + Correct Factor.
 2. If Peak Result complies with AV limit, AV Result is deemed to comply with AV limit.
 3. Peak: Peak detector.
 4. Filter losses were only considered in the spurious frequency bands and the authorized band was not corrected for High Pass Filter losses.
 5. Proper operation of the transmitter prior to adding the filter to the measurement chain.
 6. Owing to the highest peak level of unwanted emission out of the restricted bands are lower than the line(54dBuV/m) in the graph, so all the peak test point was deemed to comply with the limits -27dBm/MHz (68.2dBuV/m) list in the standard CFR 47 FCC §15.407 (b) and ISED RSS-247 6.2.



HARMONICS AND SPURIOUS EMISSIONS (HIGH CHANNEL, HORIZONTAL)

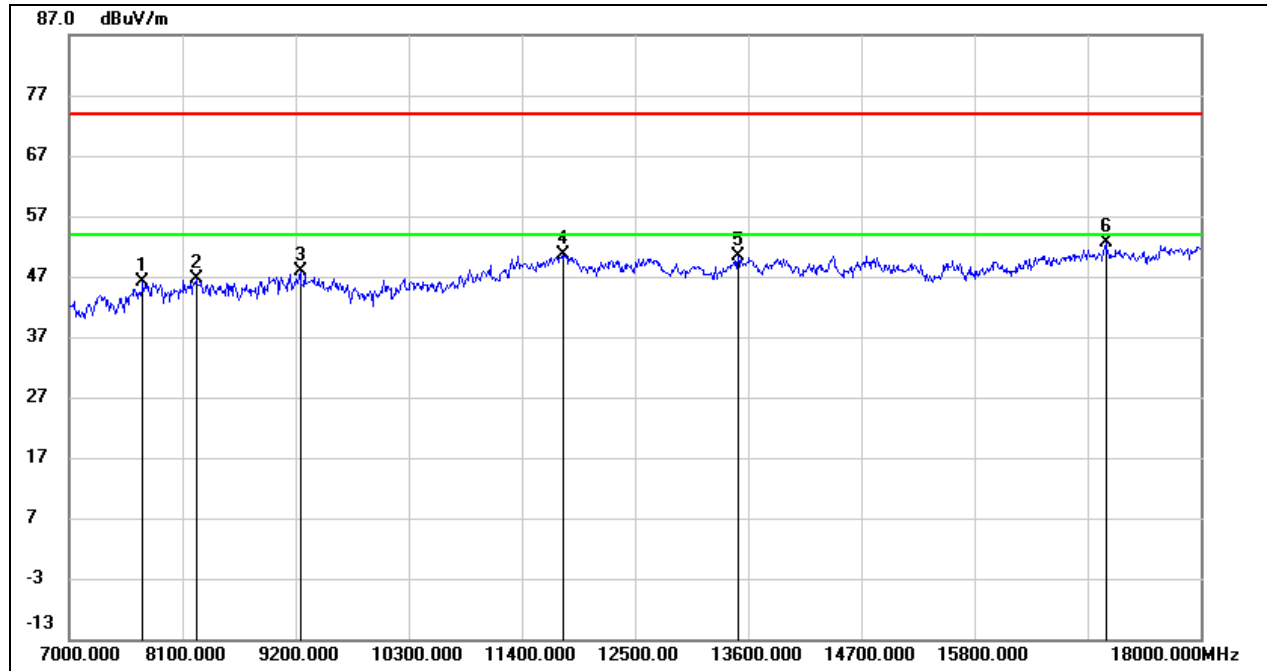

No.	Frequency (MHz)	Reading (dBuV)	Correct (dB/m)	Result (dBuV/m)	Limit (dBuV/m)	Margin (dB)	Remark
1	7715.000	38.17	7.92	46.09	74.00	-27.91	peak
2	8232.000	37.37	9.23	46.60	74.00	-27.40	peak
3	9244.000	38.46	9.51	47.97	74.00	-26.03	peak
4	11796.000	35.13	15.59	50.72	74.00	-23.28	peak
5	13501.000	33.93	16.41	50.34	74.00	-23.66	peak
6	17076.000	32.16	20.54	52.70	74.00	-21.30	peak

Note: 1. Measurement = Reading Level + Correct Factor.
 2. If Peak Result complies with AV limit, AV Result is deemed to comply with AV limit.
 3. Peak: Peak detector.
 4. Filter losses were only considered in the spurious frequency bands and the authorized band was not corrected for High Pass Filter losses.
 5. Proper operation of the transmitter prior to adding the filter to the measurement chain.
 6. Owing to the highest peak level of unwanted emission out of the restricted bands are lower than the line(54dBuV/m) in the graph, so all the peak test point was deemed to comply with the limits -27dBm/MHz (68.2dBuV/m) list in the standard CFR 47 FCC §15.407 (b) and ISED RSS-247 6.2.



HARMONICS AND SPURIOUS EMISSIONS (HIGH CHANNEL, VERTICAL)

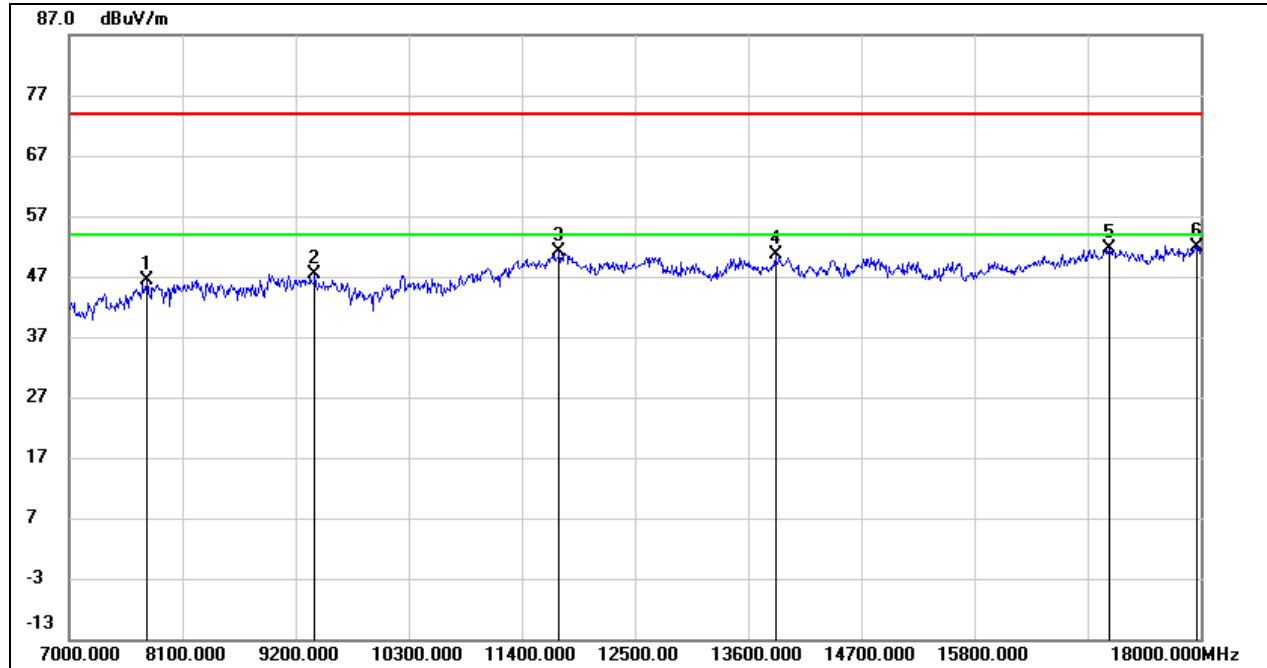

No.	Frequency (MHz)	Reading (dBuV)	Correct (dB/m)	Result (dBuV/m)	Limit (dBuV/m)	Margin (dB)	Remark
1	7759.000	38.18	8.09	46.27	74.00	-27.73	peak
2	9387.000	37.07	10.24	47.31	74.00	-26.69	peak
3	11763.000	35.61	15.41	51.02	74.00	-22.98	peak
4	13864.000	33.59	16.92	50.51	74.00	-23.49	peak
5	17109.000	30.92	20.67	51.59	74.00	-22.41	peak
6	17967.000	29.22	22.67	51.89	74.00	-22.11	peak

Note: 1. Measurement = Reading Level + Correct Factor.
 2. If Peak Result complies with AV limit, AV Result is deemed to comply with AV limit.
 3. Peak: Peak detector.
 4. Filter losses were only considered in the spurious frequency bands and the authorized band was not corrected for High Pass Filter losses.
 5. Proper operation of the transmitter prior to adding the filter to the measurement chain.
 6. Owing to the highest peak level of unwanted emission out of the restricted bands are lower than the line(54dBuV/m) in the graph, so all the peak test point was deemed to comply with the limits -27dBm/MHz (68.2dBuV/m) list in the standard CFR 47 FCC §15.407 (b) and ISED RSS-247 6.2.

STRADDLE CHANNEL 144

ANTENNA 1 TEST RESULTS (WORST CASE)

HARMONICS AND SPURIOUS EMISSIONS (HORIZONTAL)

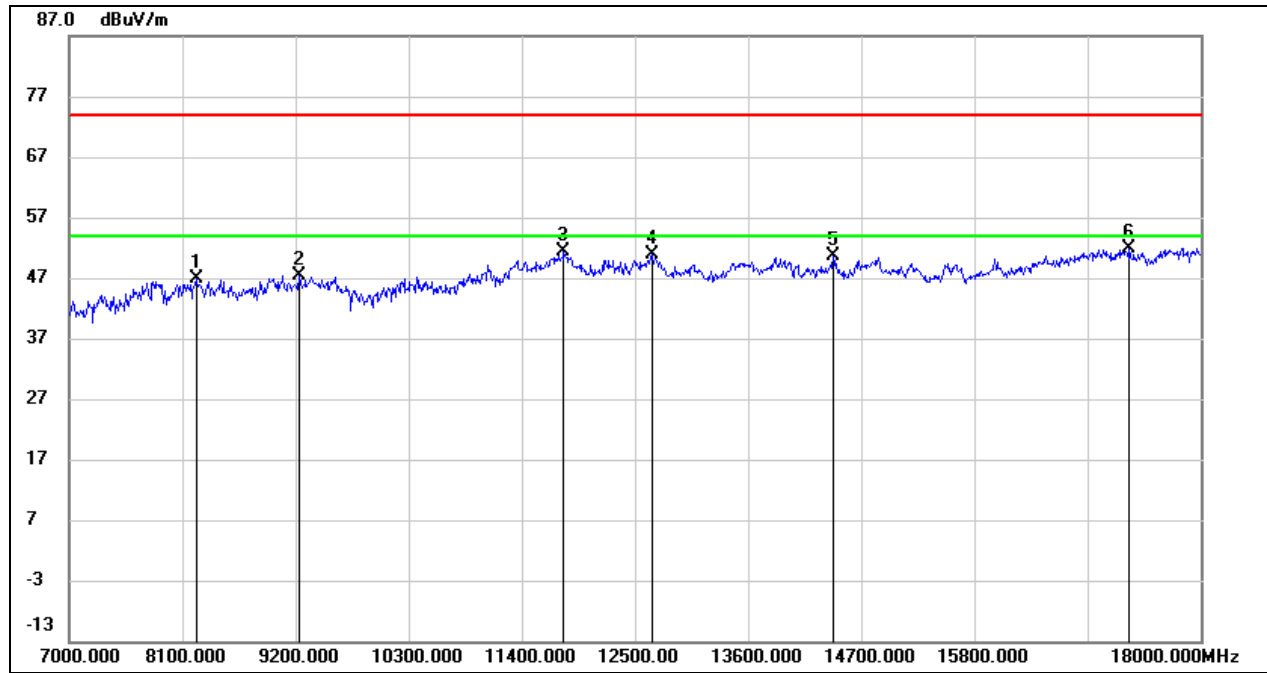

No.	Frequency (MHz)	Reading (dBuV)	Correct (dB/m)	Result (dBuV/m)	Limit (dBuV/m)	Margin (dB)	Remark
1	8232.000	37.61	9.23	46.84	74.00	-27.16	peak
2	9233.000	38.03	9.46	47.49	74.00	-26.51	peak
3	11807.000	35.65	15.61	51.26	74.00	-22.74	peak
4	12665.000	35.35	15.41	50.76	74.00	-23.24	peak
5	14425.000	33.81	16.80	50.61	74.00	-23.39	peak
6	17307.000	30.88	20.88	51.76	74.00	-22.24	peak

Note: 1. Measurement = Reading Level + Correct Factor.
 2. If Peak Result complies with AV limit, AV Result is deemed to comply with AV limit.
 3. Peak: Peak detector.
 4. Filter losses were only considered in the spurious frequency bands and the authorized band was not corrected for High Pass Filter losses.
 5. Proper operation of the transmitter prior to adding the filter to the measurement chain.
 6. Owing to the highest peak level of unwanted emission out of the restricted bands are lower than the line(54dBuV/m) in the graph, so all the peak test point was deemed to comply with the limits -27dBm/MHz (68.2dBuV/m) list in the standard CFR 47 FCC §15.407 (b) and ISED RSS-247 6.2.



HARMONICS AND SPURIOUS EMISSIONS (VERTICAL)

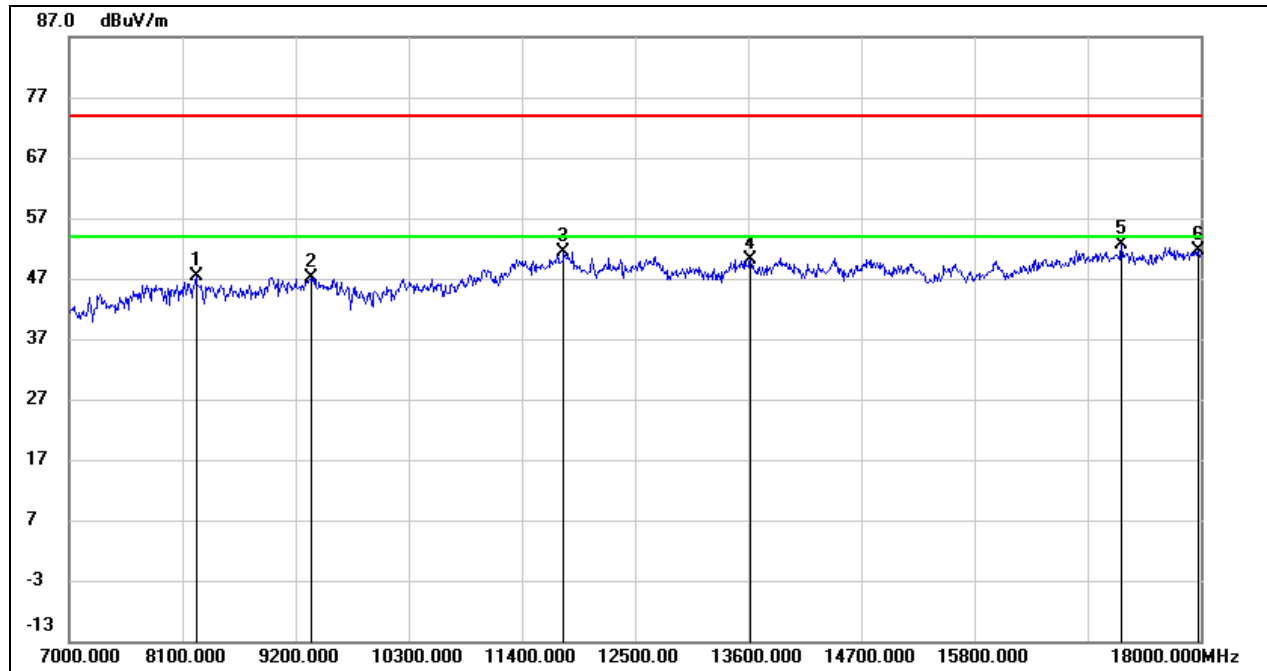

No.	Frequency (MHz)	Reading (dBuV)	Correct (dB/m)	Result (dBuV/m)	Limit (dBuV/m)	Margin (dB)	Remark
1	8232.000	38.22	9.23	47.45	74.00	-26.55	peak
2	9354.000	37.18	10.07	47.25	74.00	-26.75	peak
3	11807.000	35.83	15.61	51.44	74.00	-22.56	peak
4	13622.000	33.56	16.48	50.04	74.00	-23.96	peak
5	17230.000	31.61	20.99	52.60	74.00	-21.40	peak
6	17978.000	28.94	22.68	51.62	74.00	-22.38	peak

Note: 1. Measurement = Reading Level + Correct Factor.
 2. If Peak Result complies with AV limit, AV Result is deemed to comply with AV limit.
 3. Peak: Peak detector.
 4. Filter losses were only considered in the spurious frequency bands and the authorized band was not corrected for High Pass Filter losses.
 5. Proper operation of the transmitter prior to adding the filter to the measurement chain.
 6. Owing to the highest peak level of unwanted emission out of the restricted bands are lower than the line(54dBuV/m) in the graph, so all the peak test point was deemed to comply with the limits -27dBm/MHz (68.2dBuV/m) list in the standard CFR 47 FCC §15.407 (b) and ISED RSS-247 6.2.

UNII-3 BAND

ANTENNA 1 TEST RESULTS (WORST CASE)

HARMONICS AND SPURIOUS EMISSIONS (LOW CHANNEL, HORIZONTAL)

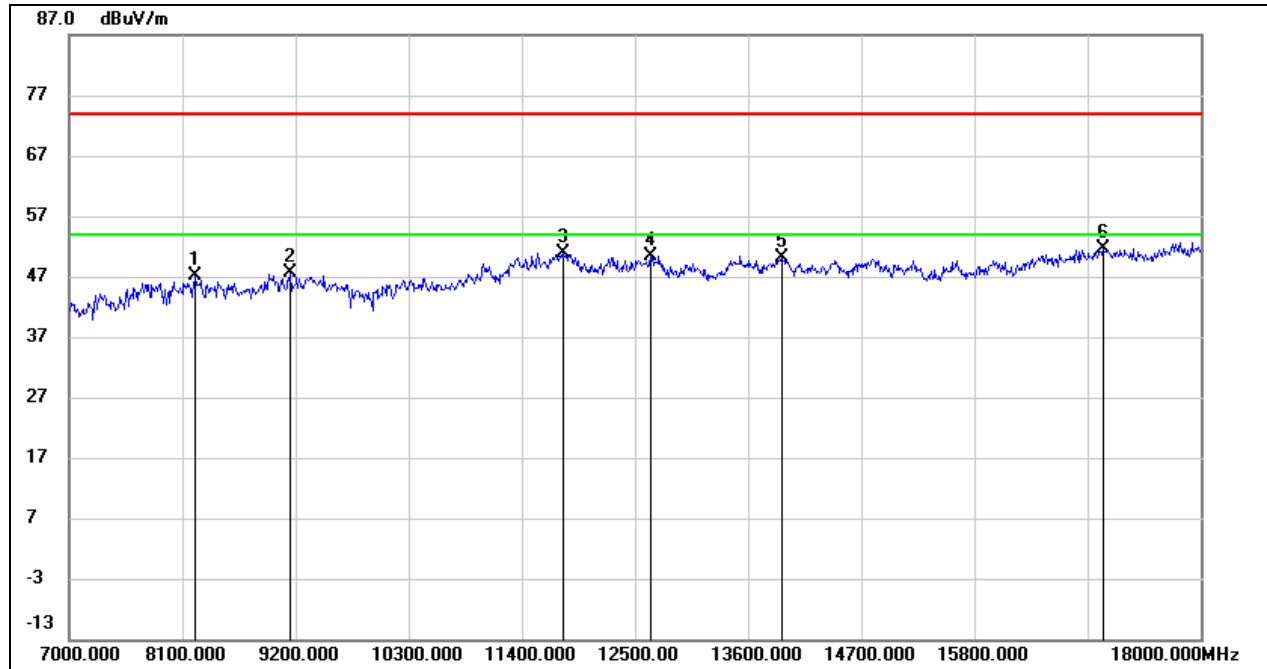

No.	Frequency (MHz)	Reading (dBuV)	Correct (dB/m)	Result (dBuV/m)	Limit (dBuV/m)	Margin (dB)	Remark
1	8221.000	37.73	9.28	47.01	74.00	-26.99	peak
2	9145.000	37.85	9.66	47.51	74.00	-26.49	peak
3	11796.000	35.37	15.59	50.96	74.00	-23.04	peak
4	12654.000	35.06	15.38	50.44	74.00	-23.56	peak
5	13930.000	33.12	16.89	50.01	74.00	-23.99	peak
6	17054.000	31.12	20.45	51.57	74.00	-22.43	peak

Note: 1. Measurement = Reading Level + Correct Factor.
 2. If Peak Result complies with AV limit, AV Result is deemed to comply with AV limit.
 3. Peak: Peak detector.
 4. Filter losses were only considered in the spurious frequency bands and the authorized band was not corrected for High Pass Filter losses.
 5. Proper operation of the transmitter prior to adding the filter to the measurement chain.
 6. Owing to the highest peak level of unwanted emission out of the restricted bands are lower than the line(54dBuV/m) in the graph, so all the peak test point was deemed to comply with the limits -27dBm/MHz (68.2dBuV/m) list in the standard CFR 47 FCC §15.407 (b) and ISED RSS-247 6.2.



HARMONICS AND SPURIOUS EMISSIONS (LOW CHANNEL, VERTICAL)

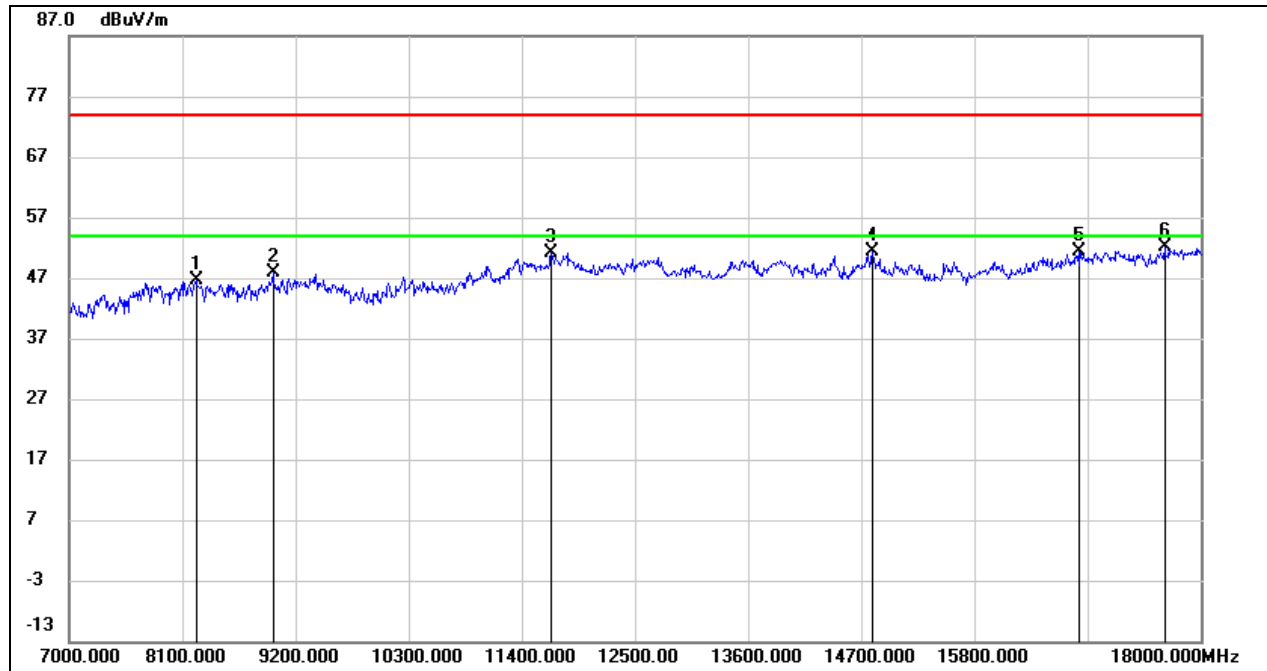

No.	Frequency (MHz)	Reading (dBuV)	Correct (dB/m)	Result (dBuV/m)	Limit (dBuV/m)	Margin (dB)	Remark
1	8232.000	37.40	9.23	46.63	74.00	-27.37	peak
2	8980.000	37.38	10.41	47.79	74.00	-26.21	peak
3	11686.000	36.05	14.99	51.04	74.00	-22.96	peak
4	14810.000	34.59	16.80	51.39	74.00	-22.61	peak
5	16812.000	31.60	19.77	51.37	74.00	-22.63	peak
6	17648.000	30.55	21.54	52.09	74.00	-21.91	peak

Note: 1. Measurement = Reading Level + Correct Factor.
 2. If Peak Result complies with AV limit, AV Result is deemed to comply with AV limit.
 3. Peak: Peak detector.
 4. Filter losses were only considered in the spurious frequency bands and the authorized band was not corrected for High Pass Filter losses.
 5. Proper operation of the transmitter prior to adding the filter to the measurement chain.
 6. Owing to the highest peak level of unwanted emission out of the restricted bands are lower than the line(54dBuV/m) in the graph, so all the peak test point was deemed to comply with the limits -27dBm/MHz (68.2dBuV/m) list in the standard CFR 47 FCC §15.407 (b) and ISED RSS-247 6.2.



HARMONICS AND SPURIOUS EMISSIONS (MID CHANNEL, HORIZONTAL)

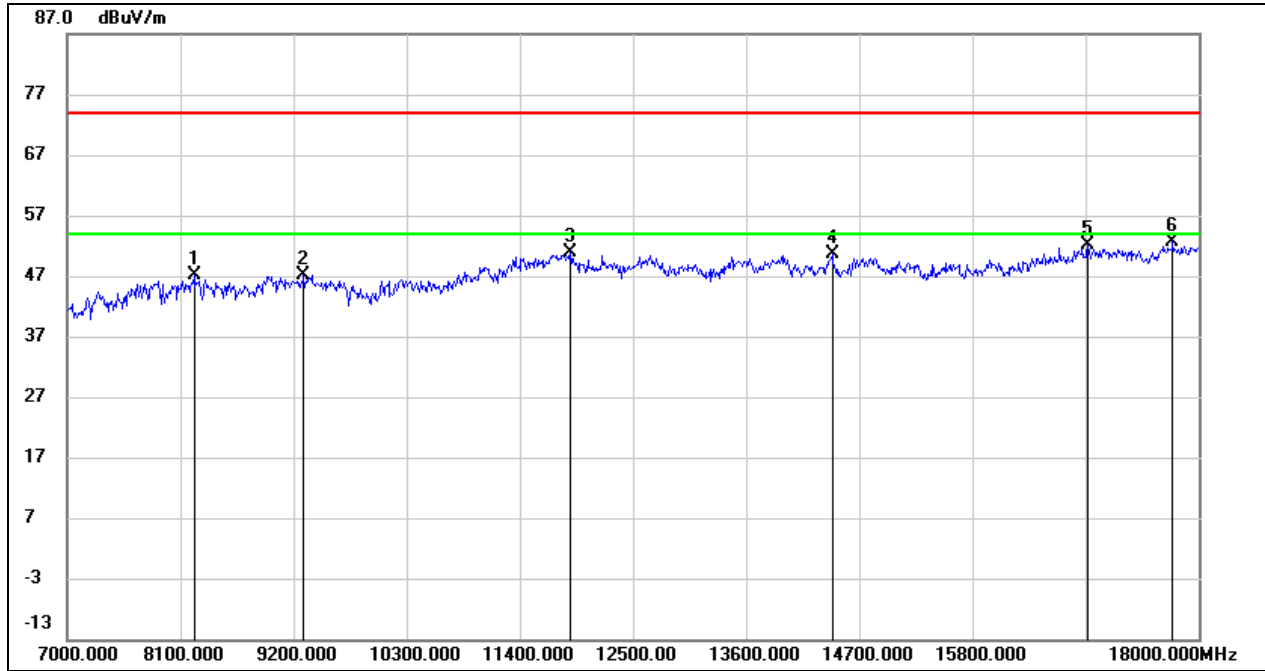

No.	Frequency (MHz)	Reading (dBuV)	Correct (dB/m)	Result (dBuV/m)	Limit (dBuV/m)	Margin (dB)	Remark
1	8232.000	37.91	9.23	47.14	74.00	-26.86	peak
2	9299.000	37.44	9.80	47.24	74.00	-26.76	peak
3	11895.000	35.29	15.48	50.77	74.00	-23.23	peak
4	14436.000	33.86	16.79	50.65	74.00	-23.35	peak
5	16922.000	32.05	20.04	52.09	74.00	-21.91	peak
6	17747.000	30.29	22.31	52.60	74.00	-21.40	peak

Note: 1. Measurement = Reading Level + Correct Factor.
 2. If Peak Result complies with AV limit, AV Result is deemed to comply with AV limit.
 3. Peak: Peak detector.
 4. Filter losses were only considered in the spurious frequency bands and the authorized band was not corrected for High Pass Filter losses.
 5. Proper operation of the transmitter prior to adding the filter to the measurement chain.
 6. Owing to the highest peak level of unwanted emission out of the restricted bands are lower than the line(54dBuV/m) in the graph, so all the peak test point was deemed to comply with the limits -27dBm/MHz (68.2dBuV/m) list in the standard CFR 47 FCC §15.407 (b) and ISED RSS-247 6.2.



HARMONICS AND SPURIOUS EMISSIONS (MID CHANNEL, VERTICAL)

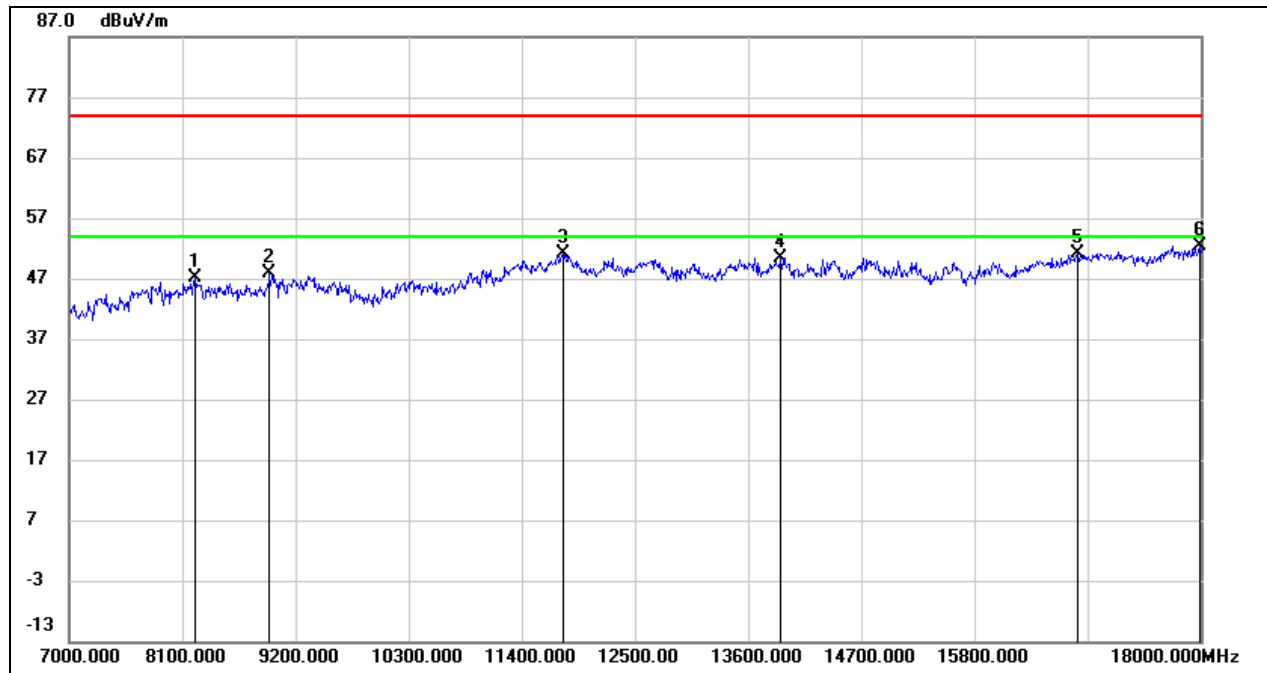

No.	Frequency (MHz)	Reading (dBuV)	Correct (dB/m)	Result (dBuV/m)	Limit (dBuV/m)	Margin (dB)	Remark
1	8221.000	37.90	9.28	47.18	74.00	-26.82	peak
2	8947.000	37.79	10.07	47.86	74.00	-26.14	peak
3	11796.000	35.47	15.59	51.06	74.00	-22.94	peak
4	13919.000	33.59	16.89	50.48	74.00	-23.52	peak
5	16801.000	31.44	19.74	51.18	74.00	-22.82	peak
6	17989.000	29.75	22.67	52.42	74.00	-21.58	peak

Note: 1. Measurement = Reading Level + Correct Factor.
 2. If Peak Result complies with AV limit, AV Result is deemed to comply with AV limit.
 3. Peak: Peak detector.
 4. Filter losses were only considered in the spurious frequency bands and the authorized band was not corrected for High Pass Filter losses.
 5. Proper operation of the transmitter prior to adding the filter to the measurement chain.
 6. Owing to the highest peak level of unwanted emission out of the restricted bands are lower than the line(54dBuV/m) in the graph, so all the peak test point was deemed to comply with the limits -27dBm/MHz (68.2dBuV/m) list in the standard CFR 47 FCC §15.407 (b) and ISED RSS-247 6.2.



HARMONICS AND SPURIOUS EMISSIONS (HIGH CHANNEL, HORIZONTAL)

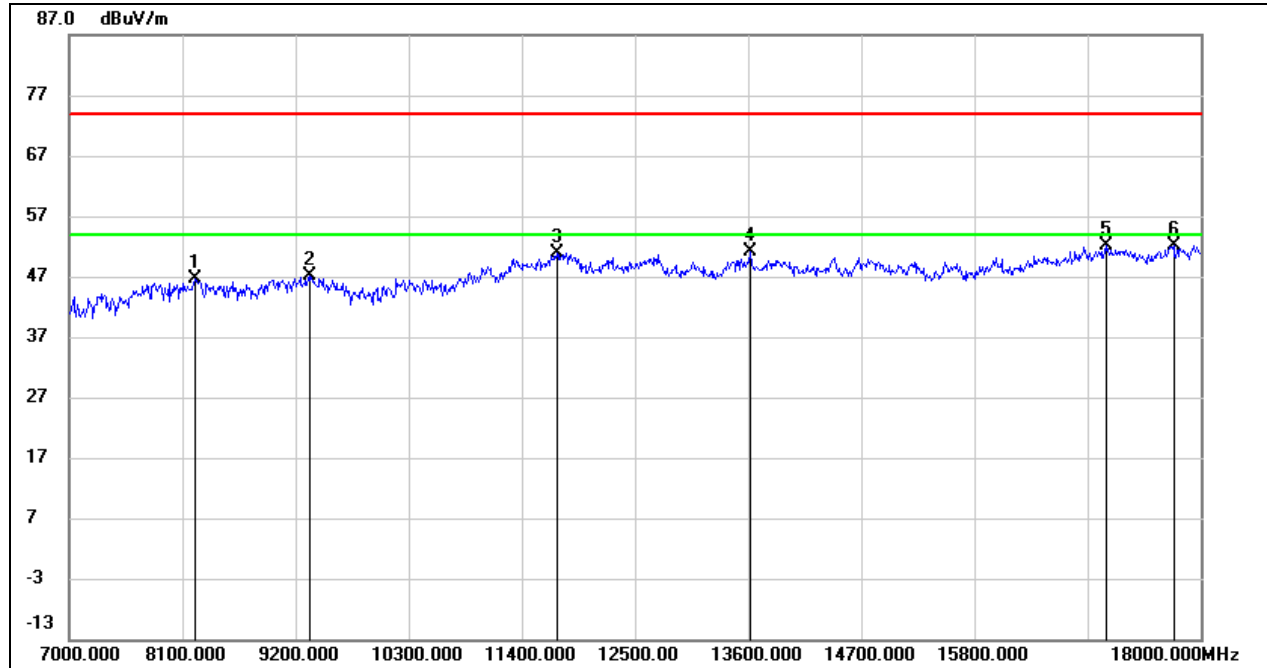

No.	Frequency (MHz)	Reading (dBuV)	Correct (dB/m)	Result (dBuV/m)	Limit (dBuV/m)	Margin (dB)	Remark
1	8221.000	37.40	9.28	46.68	74.00	-27.32	peak
2	9332.000	37.13	9.97	47.10	74.00	-26.90	peak
3	11741.000	35.69	15.28	50.97	74.00	-23.03	peak
4	13622.000	34.54	16.48	51.02	74.00	-22.98	peak
5	17076.000	31.62	20.54	52.16	74.00	-21.84	peak
6	17736.000	29.95	22.22	52.17	74.00	-21.83	peak

Note: 1. Measurement = Reading Level + Correct Factor.
 2. If Peak Result complies with AV limit, AV Result is deemed to comply with AV limit.
 3. Peak: Peak detector.
 4. Filter losses were only considered in the spurious frequency bands and the authorized band was not corrected for High Pass Filter losses.
 5. Proper operation of the transmitter prior to adding the filter to the measurement chain.
 6. Owing to the highest peak level of unwanted emission out of the restricted bands are lower than the line(54dBuV/m) in the graph, so all the peak test point was deemed to comply with the limits -27dBm/MHz (68.2dBuV/m) list in the standard CFR 47 FCC §15.407 (b) and ISED RSS-247 6.2.



HARMONICS AND SPURIOUS EMISSIONS (HIGH CHANNEL, VERTICAL)

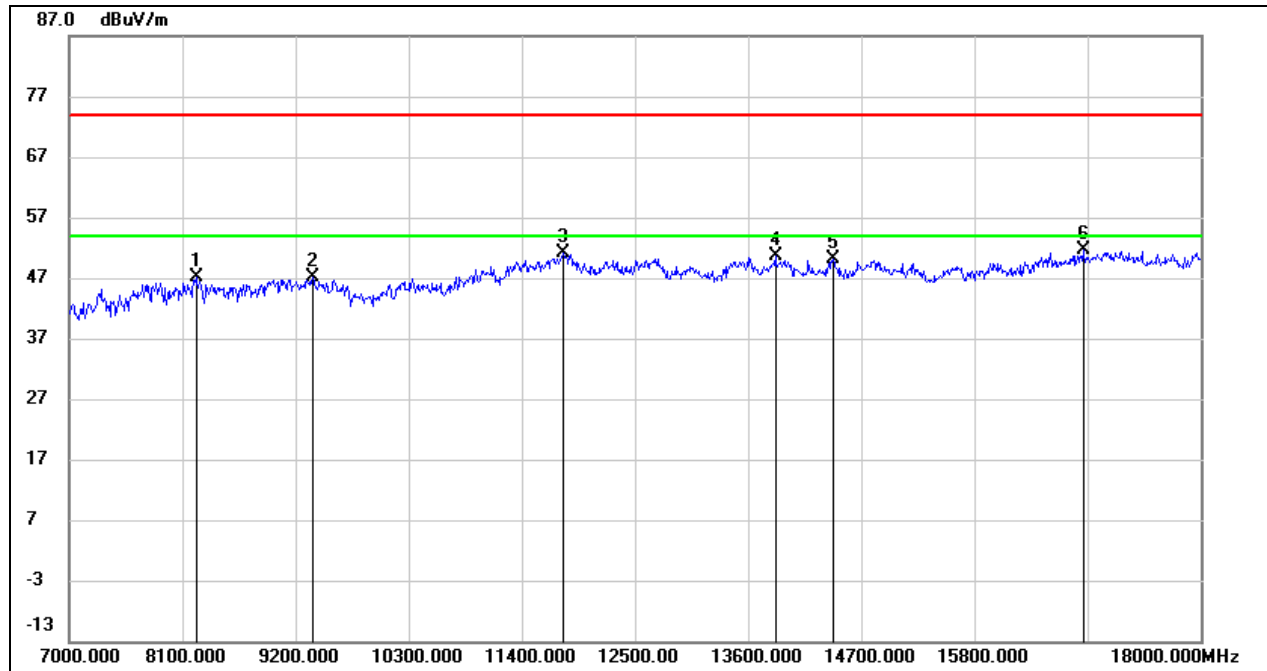

No.	Frequency (MHz)	Reading (dBuV)	Correct (dB/m)	Result (dBuV/m)	Limit (dBuV/m)	Margin (dB)	Remark
1	8232.000	37.99	9.23	47.22	74.00	-26.78	peak
2	9365.000	36.88	10.13	47.01	74.00	-26.99	peak
3	11807.000	35.51	15.61	51.12	74.00	-22.88	peak
4	13864.000	33.71	16.92	50.63	74.00	-23.37	peak
5	14425.000	33.33	16.80	50.13	74.00	-23.87	peak
6	16856.000	31.71	19.87	51.58	74.00	-22.42	peak

Note: 1. Measurement = Reading Level + Correct Factor.
 2. If Peak Result complies with AV limit, AV Result is deemed to comply with AV limit.
 3. Peak: Peak detector.
 4. Filter losses were only considered in the spurious frequency bands and the authorized band was not corrected for High Pass Filter losses.
 5. Proper operation of the transmitter prior to adding the filter to the measurement chain.
 6. Owing to the highest peak level of unwanted emission out of the restricted bands are lower than the line(54dBuV/m) in the graph, so all the peak test point was deemed to comply with the limits -27dBm/MHz (68.2dBuV/m) list in the standard CFR 47 FCC §15.407 (b) and ISED RSS-247 6.2.

8.3.2. 802.11ac VHT20 MIMO MODE

UNII-1 BAND

HARMONICS AND SPURIOUS EMISSIONS (LOW CHANNEL, HORIZONTAL)

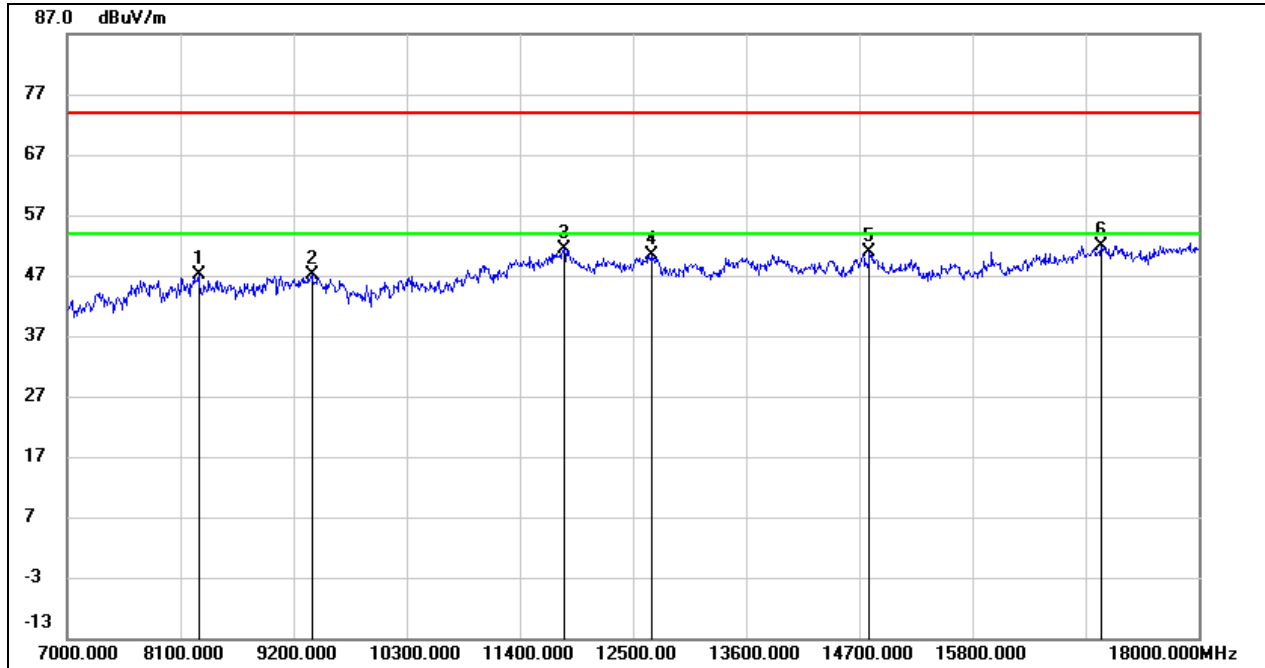

No.	Frequency (MHz)	Reading (dBuV)	Correct (dB/m)	Result (dBuV/m)	Limit (dBuV/m)	Margin (dB)	Remark
1	8276.000	37.99	9.06	47.05	74.00	-26.95	peak
2	9376.000	36.92	10.19	47.11	74.00	-26.89	peak
3	11829.000	35.80	15.57	51.37	74.00	-22.63	peak
4	12676.000	34.92	15.42	50.34	74.00	-23.66	peak
5	14799.000	34.07	16.80	50.87	74.00	-23.13	peak
6	17054.000	31.55	20.45	52.00	74.00	-22.00	peak

Note: 1. Measurement = Reading Level + Correct Factor.
 2. If Peak Result complies with AV limit, AV Result is deemed to comply with AV limit.
 3. Peak: Peak detector.
 4. Filter losses were only considered in the spurious frequency bands and the authorized band was not corrected for High Pass Filter losses.
 5. Proper operation of the transmitter prior to adding the filter to the measurement chain.
 6. Owing to the highest peak level of unwanted emission out of the restricted bands are lower than the line(54dBuV/m) in the graph, so all the peak test point was deemed to comply with the limits -27dBm/MHz (68.2dBuV/m) list in the standard CFR 47 FCC §15.407 (b) and ISSED RSS-247 6.2.

HARMONICS AND SPURIOUS EMISSIONS (LOW CHANNEL, VERTICAL)

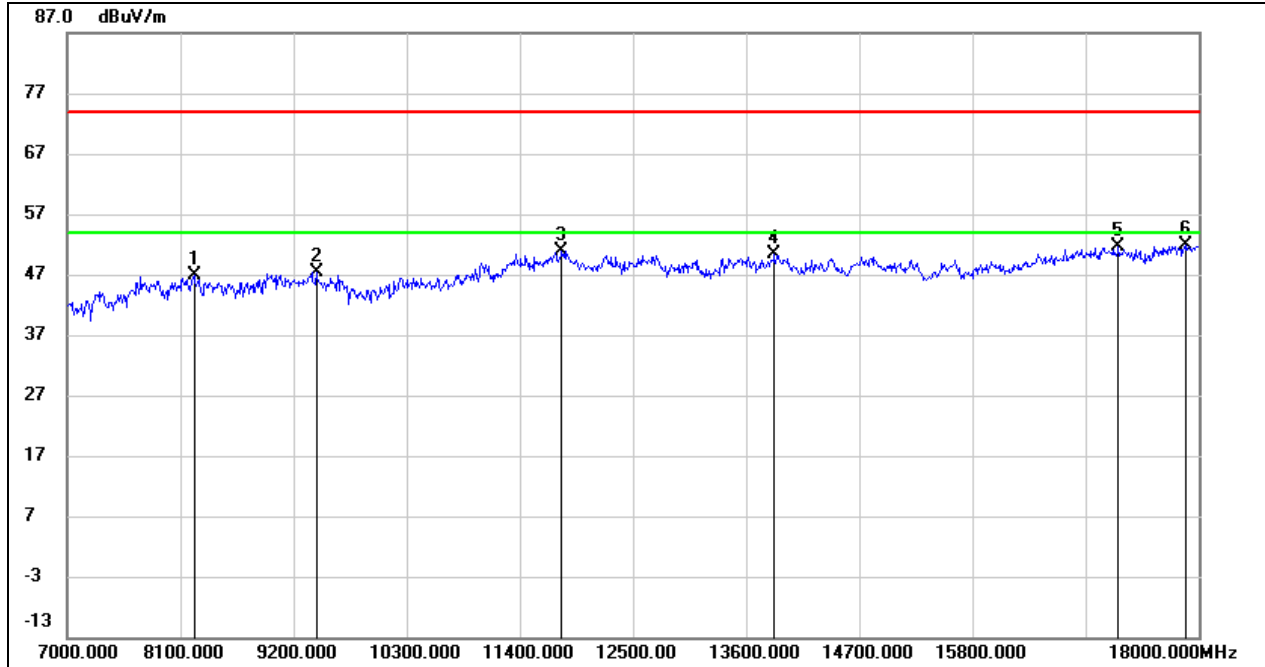

No.	Frequency (MHz)	Reading (dBuV)	Correct (dB/m)	Result (dBuV/m)	Limit (dBuV/m)	Margin (dB)	Remark
1	8232.000	37.55	9.23	46.78	74.00	-27.22	peak
2	9420.000	37.01	10.34	47.35	74.00	-26.65	peak
3	11807.000	35.36	15.61	50.97	74.00	-23.03	peak
4	13875.000	33.38	16.92	50.30	74.00	-23.70	peak
5	17219.000	30.68	21.01	51.69	74.00	-22.31	peak
6	17879.000	29.21	22.70	51.91	74.00	-22.09	peak

Note: 1. Measurement = Reading Level + Correct Factor.
 2. If Peak Result complies with AV limit, AV Result is deemed to comply with AV limit.
 3. Peak: Peak detector.
 4. Filter losses were only considered in the spurious frequency bands and the authorized band was not corrected for High Pass Filter losses.
 5. Proper operation of the transmitter prior to adding the filter to the measurement chain.
 6. Owing to the highest peak level of unwanted emission out of the restricted bands are lower than the line(54dBuV/m) in the graph, so all the peak test point was deemed to comply with the limits -27dBm/MHz (68.2dBuV/m) list in the standard CFR 47 FCC §15.407 (b) and ISED RSS-247 6.2.



HARMONICS AND SPURIOUS EMISSIONS (MID CHANNEL, HORIZONTAL)

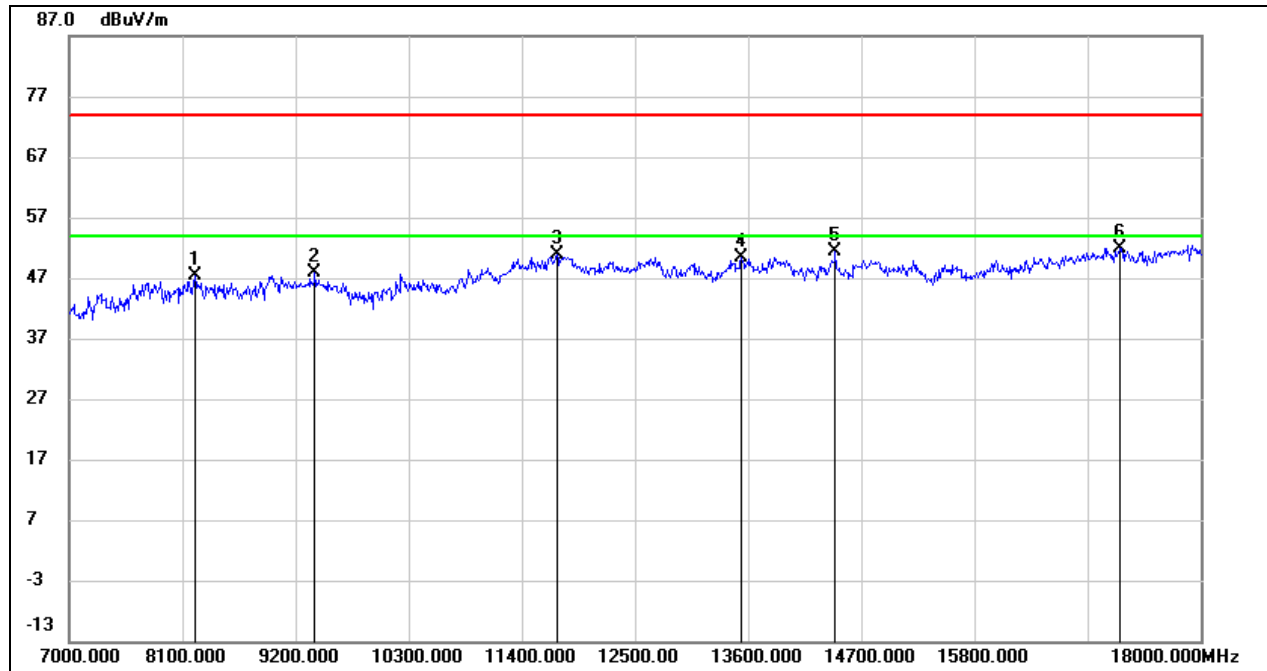

No.	Frequency (MHz)	Reading (dBuV)	Correct (dB/m)	Result (dBuV/m)	Limit (dBuV/m)	Margin (dB)	Remark
1	8221.000	38.01	9.28	47.29	74.00	-26.71	peak
2	9387.000	37.56	10.24	47.80	74.00	-26.20	peak
3	11741.000	35.71	15.28	50.99	74.00	-23.01	peak
4	13534.000	33.87	16.42	50.29	74.00	-23.71	peak
5	14447.000	34.72	16.77	51.49	74.00	-22.51	peak
6	17219.000	30.90	21.01	51.91	74.00	-22.09	peak

Note: 1. Measurement = Reading Level + Correct Factor.
 2. If Peak Result complies with AV limit, AV Result is deemed to comply with AV limit.
 3. Peak: Peak detector.
 4. Filter losses were only considered in the spurious frequency bands and the authorized band was not corrected for High Pass Filter losses.
 5. Proper operation of the transmitter prior to adding the filter to the measurement chain.
 6. Owing to the highest peak level of unwanted emission out of the restricted bands are lower than the line(54dBuV/m) in the graph, so all the peak test point was deemed to comply with the limits -27dBm/MHz (68.2dBuV/m) list in the standard CFR 47 FCC §15.407 (b) and ISED RSS-247 6.2.



HARMONICS AND SPURIOUS EMISSIONS (MID CHANNEL, VERTICAL)

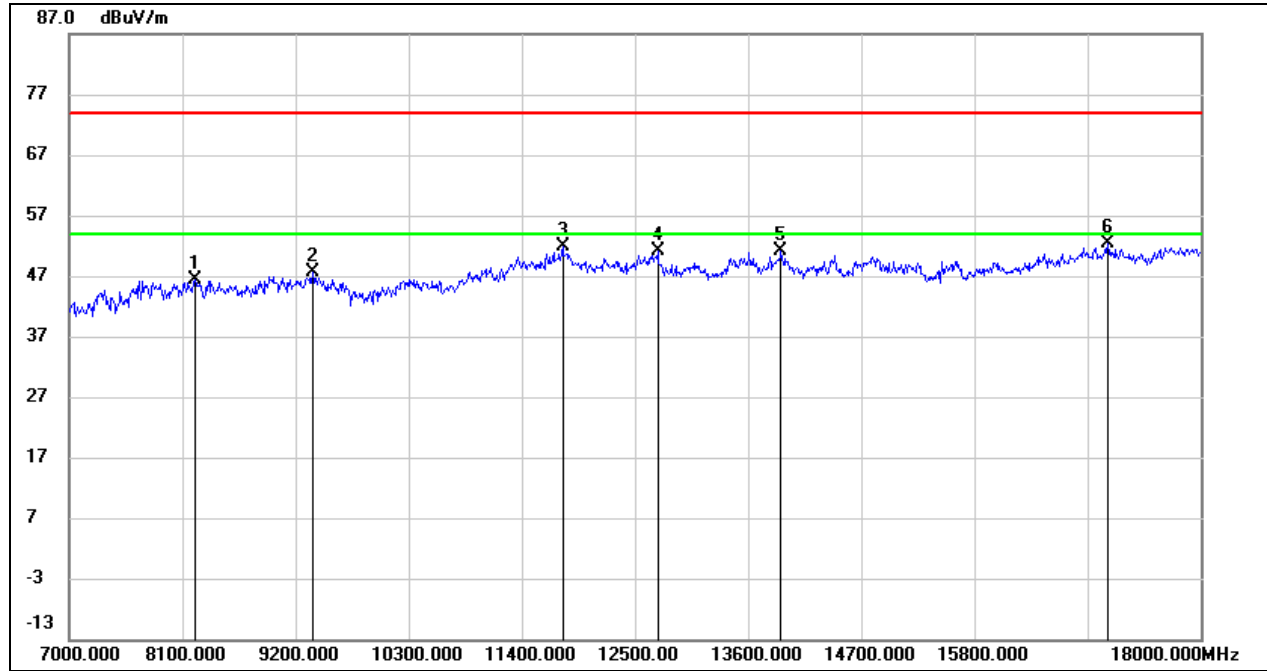

No.	Frequency (MHz)	Reading (dBuV)	Correct (dB/m)	Result (dBuV/m)	Limit (dBuV/m)	Margin (dB)	Remark
1	8221.000	37.15	9.28	46.43	74.00	-27.57	peak
2	9365.000	37.40	10.13	47.53	74.00	-26.47	peak
3	11796.000	36.18	15.59	51.77	74.00	-22.23	peak
4	12720.000	35.54	15.51	51.05	74.00	-22.95	peak
5	13919.000	34.26	16.89	51.15	74.00	-22.85	peak
6	17098.000	31.63	20.63	52.26	74.00	-21.74	peak

Note: 1. Measurement = Reading Level + Correct Factor.
 2. If Peak Result complies with AV limit, AV Result is deemed to comply with AV limit.
 3. Peak: Peak detector.
 4. Filter losses were only considered in the spurious frequency bands and the authorized band was not corrected for High Pass Filter losses.
 5. Proper operation of the transmitter prior to adding the filter to the measurement chain.
 6. Owing to the highest peak level of unwanted emission out of the restricted bands are lower than the line(54dBuV/m) in the graph, so all the peak test point was deemed to comply with the limits -27dBm/MHz (68.2dBuV/m) list in the standard CFR 47 FCC §15.407 (b) and ISED RSS-247 6.2.



HARMONICS AND SPURIOUS EMISSIONS (HIGH CHANNEL, HORIZONTAL)

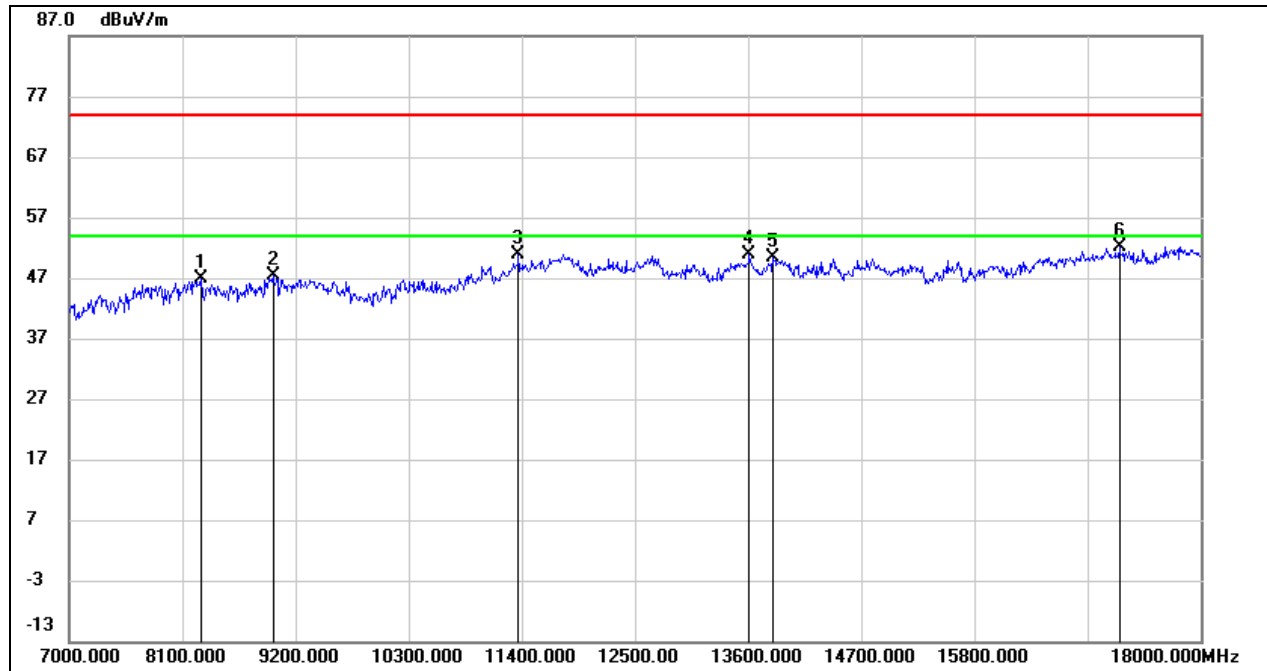

No.	Frequency (MHz)	Reading (dBuV)	Correct (dB/m)	Result (dBuV/m)	Limit (dBuV/m)	Margin (dB)	Remark
1	8276.000	37.94	9.06	47.00	74.00	-27.00	peak
2	8980.000	36.89	10.41	47.30	74.00	-26.70	peak
3	11367.000	36.88	14.11	50.99	74.00	-23.01	peak
4	13611.000	34.32	16.45	50.77	74.00	-23.23	peak
5	13842.000	33.32	16.94	50.26	74.00	-23.74	peak
6	17208.000	31.09	21.03	52.12	74.00	-21.88	peak

Note: 1. Measurement = Reading Level + Correct Factor.
 2. If Peak Result complies with AV limit, AV Result is deemed to comply with AV limit.
 3. Peak: Peak detector.
 4. Filter losses were only considered in the spurious frequency bands and the authorized band was not corrected for High Pass Filter losses.
 5. Proper operation of the transmitter prior to adding the filter to the measurement chain.
 6. Owing to the highest peak level of unwanted emission out of the restricted bands are lower than the line(54dBuV/m) in the graph, so all the peak test point was deemed to comply with the limits -27dBm/MHz (68.2dBuV/m) list in the standard CFR 47 FCC §15.407 (b) and ISSED RSS-247 6.2.



HARMONICS AND SPURIOUS EMISSIONS (HIGH CHANNEL, VERTICAL)

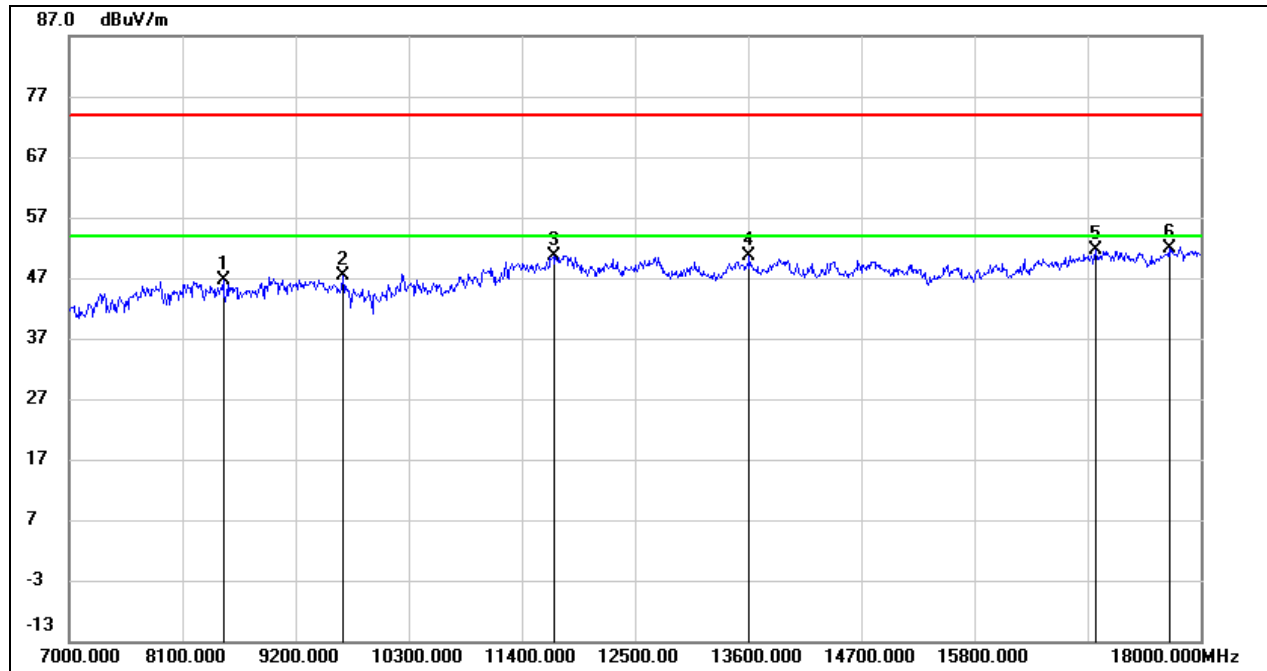

No.	Frequency (MHz)	Reading (dBuV)	Correct (dB/m)	Result (dBuV/m)	Limit (dBuV/m)	Margin (dB)	Remark
1	8496.000	38.11	8.53	46.64	74.00	-27.36	peak
2	9662.000	36.98	10.32	47.30	74.00	-26.70	peak
3	11708.000	35.64	15.11	50.75	74.00	-23.25	peak
4	13611.000	34.24	16.45	50.69	74.00	-23.31	peak
5	16977.000	31.40	20.17	51.57	74.00	-22.43	peak
6	17692.000	29.91	21.87	51.78	74.00	-22.22	peak

Note: 1. Measurement = Reading Level + Correct Factor.
 2. If Peak Result complies with AV limit, AV Result is deemed to comply with AV limit.
 3. Peak: Peak detector.
 4. Filter losses were only considered in the spurious frequency bands and the authorized band was not corrected for High Pass Filter losses.
 5. Proper operation of the transmitter prior to adding the filter to the measurement chain.
 6. Owing to the highest peak level of unwanted emission out of the restricted bands are lower than the line(54dBuV/m) in the graph, so all the peak test point was deemed to comply with the limits -27dBm/MHz (68.2dBuV/m) list in the standard CFR 47 FCC §15.407 (b) and ISED RSS-247 6.2.



UNII-2A BAND

HARMONICS AND SPURIOUS EMISSIONS (LOW CHANNEL, HORIZONTAL)

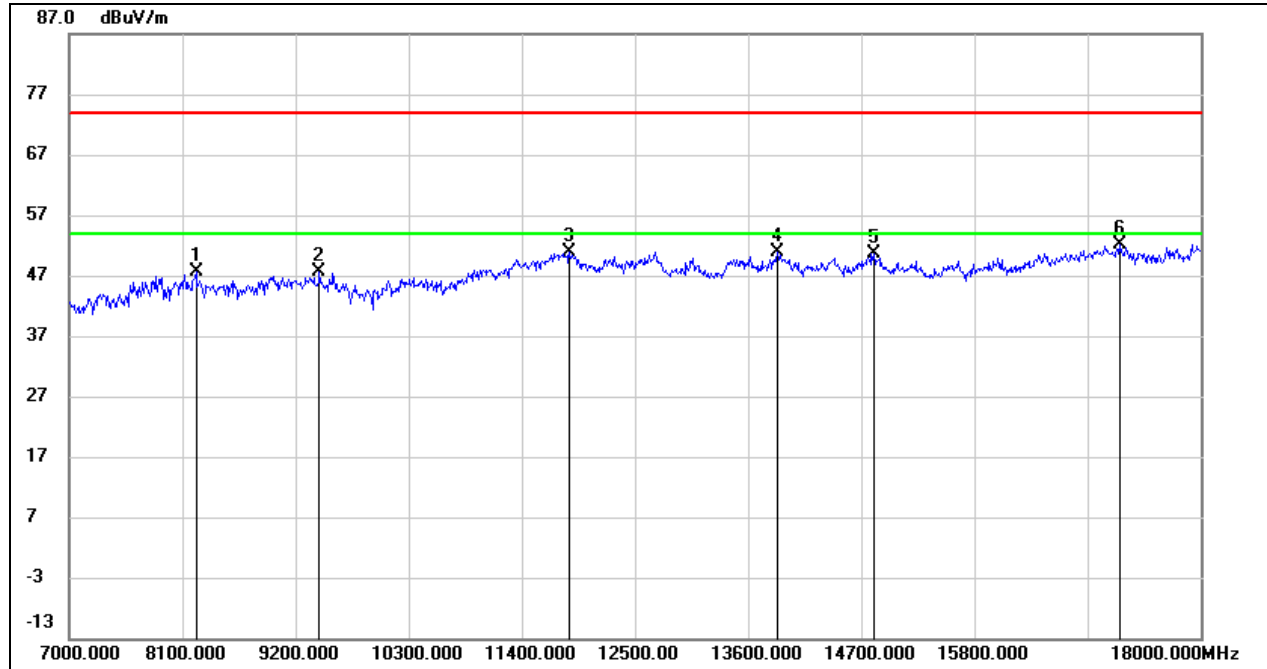

No.	Frequency (MHz)	Reading (dBuV)	Correct (dB/m)	Result (dBuV/m)	Limit (dBuV/m)	Margin (dB)	Remark
1	8232.000	38.48	9.23	47.71	74.00	-26.29	peak
2	9431.000	37.16	10.35	47.51	74.00	-26.49	peak
3	11862.000	35.36	15.52	50.88	74.00	-23.12	peak
4	13886.000	34.07	16.91	50.98	74.00	-23.02	peak
5	14821.000	33.94	16.81	50.75	74.00	-23.25	peak
6	17208.000	31.03	21.03	52.06	74.00	-21.94	peak

Note: 1. Measurement = Reading Level + Correct Factor.
 2. If Peak Result complies with AV limit, AV Result is deemed to comply with AV limit.
 3. Peak: Peak detector.
 4. Filter losses were only considered in the spurious frequency bands and the authorized band was not corrected for High Pass Filter losses.
 5. Proper operation of the transmitter prior to adding the filter to the measurement chain.
 6. Owing to the highest peak level of unwanted emission out of the restricted bands are lower than the line(54dBuV/m) in the graph, so all the peak test point was deemed to comply with the limits -27dBm/MHz (68.2dBuV/m) list in the standard CFR 47 FCC §15.407 (b) and ISED RSS-247 6.2.

HARMONICS AND SPURIOUS EMISSIONS (LOW CHANNEL, VERTICAL)

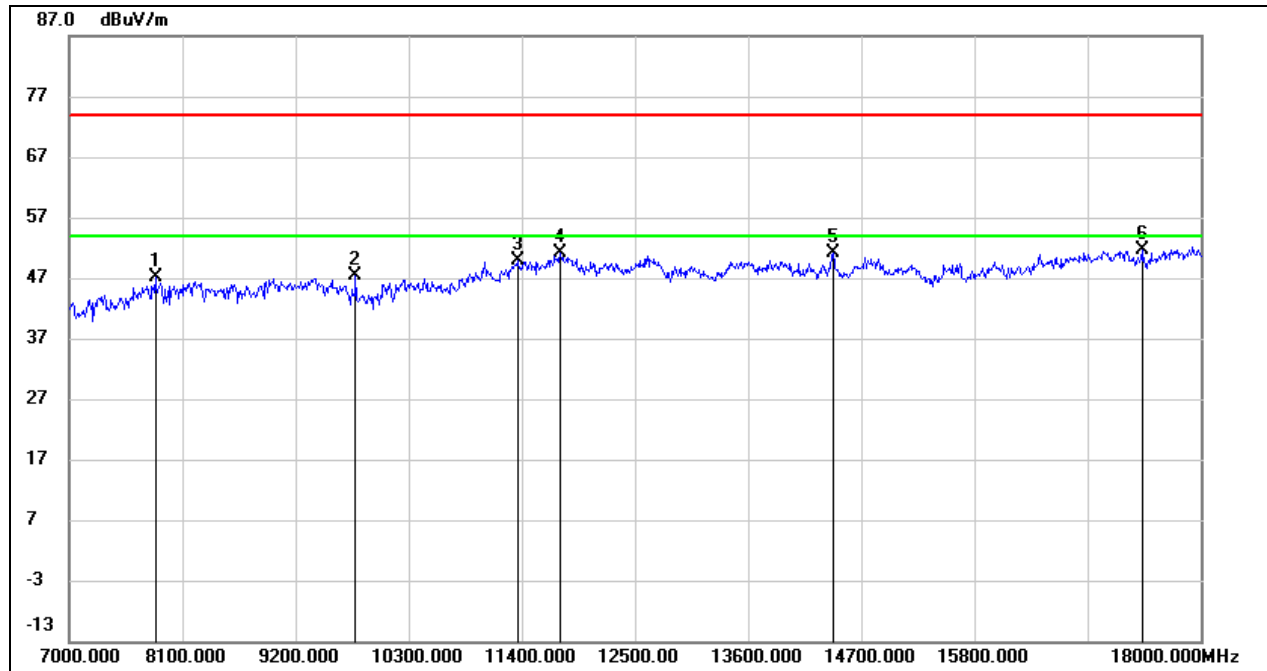

No.	Frequency (MHz)	Reading (dBuV)	Correct (dB/m)	Result (dBuV/m)	Limit (dBuV/m)	Margin (dB)	Remark
1	7836.000	38.89	8.14	47.03	74.00	-26.97	peak
2	9783.000	37.31	10.01	47.32	74.00	-26.68	peak
3	11356.000	35.78	14.09	49.87	74.00	-24.13	peak
4	11774.000	35.67	15.47	51.14	74.00	-22.86	peak
5	14425.000	34.34	16.80	51.14	74.00	-22.86	peak
6	17428.000	30.99	20.76	51.75	74.00	-22.25	peak

Note: 1. Measurement = Reading Level + Correct Factor.
 2. If Peak Result complies with AV limit, AV Result is deemed to comply with AV limit.
 3. Peak: Peak detector.
 4. Filter losses were only considered in the spurious frequency bands and the authorized band was not corrected for High Pass Filter losses.
 5. Proper operation of the transmitter prior to adding the filter to the measurement chain.
 6. Owing to the highest peak level of unwanted emission out of the restricted bands are lower than the line(54dBuV/m) in the graph, so all the peak test point was deemed to comply with the limits -27dBm/MHz (68.2dBuV/m) list in the standard CFR 47 FCC §15.407 (b) and ISED RSS-247 6.2.

HARMONICS AND SPURIOUS EMISSIONS (MID CHANNEL, HORIZONTAL)

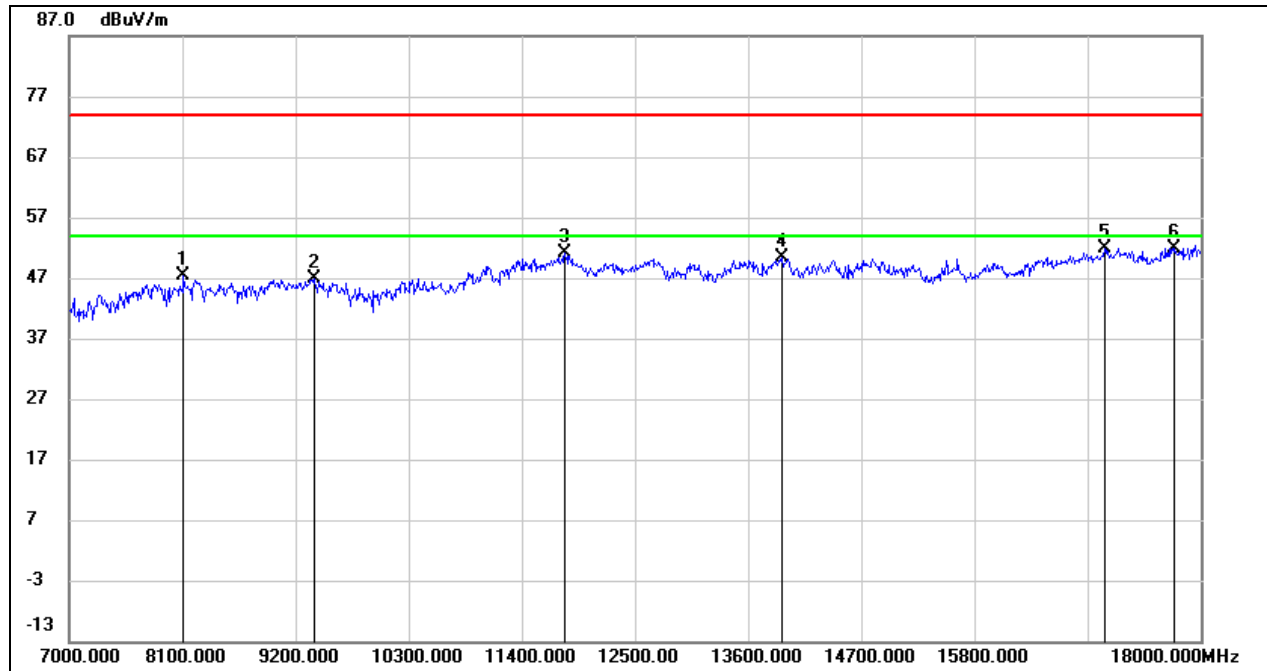

No.	Frequency (MHz)	Reading (dBuV)	Correct (dB/m)	Result (dBuV/m)	Limit (dBuV/m)	Margin (dB)	Remark
1	8111.000	38.80	8.61	47.41	74.00	-26.59	peak
2	9376.000	36.72	10.19	46.91	74.00	-27.09	peak
3	11818.000	35.53	15.58	51.11	74.00	-22.89	peak
4	13930.000	33.51	16.89	50.40	74.00	-23.60	peak
5	17065.000	31.34	20.49	51.83	74.00	-22.17	peak
6	17747.000	29.68	22.31	51.99	74.00	-22.01	peak

Note: 1. Measurement = Reading Level + Correct Factor.
 2. If Peak Result complies with AV limit, AV Result is deemed to comply with AV limit.
 3. Peak: Peak detector.
 4. Filter losses were only considered in the spurious frequency bands and the authorized band was not corrected for High Pass Filter losses.
 5. Proper operation of the transmitter prior to adding the filter to the measurement chain.
 6. Owing to the highest peak level of unwanted emission out of the restricted bands are lower than the line(54dBuV/m) in the graph, so all the peak test point was deemed to comply with the limits -27dBm/MHz (68.2dBuV/m) list in the standard CFR 47 FCC §15.407 (b) and ISED RSS-247 6.2.



HARMONICS AND SPURIOUS EMISSIONS (MID CHANNEL, VERTICAL)

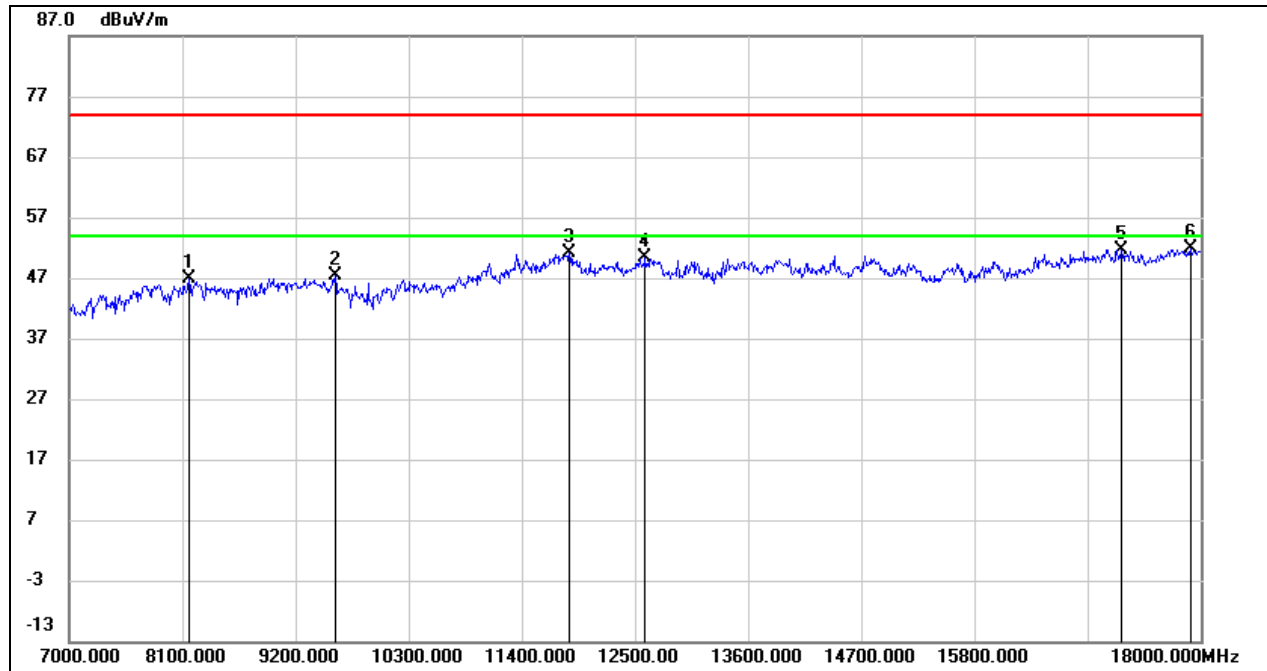

No.	Frequency (MHz)	Reading (dBuV)	Correct (dB/m)	Result (dBuV/m)	Limit (dBuV/m)	Margin (dB)	Remark
1	8166.000	37.77	9.07	46.84	74.00	-27.16	peak
2	9585.000	37.01	10.47	47.48	74.00	-26.52	peak
3	11862.000	35.49	15.52	51.01	74.00	-22.99	peak
4	12599.000	34.98	15.29	50.27	74.00	-23.73	peak
5	17230.000	30.62	20.99	51.61	74.00	-22.39	peak
6	17901.000	29.09	22.69	51.78	74.00	-22.22	peak

Note: 1. Measurement = Reading Level + Correct Factor.
 2. If Peak Result complies with AV limit, AV Result is deemed to comply with AV limit.
 3. Peak: Peak detector.
 4. Filter losses were only considered in the spurious frequency bands and the authorized band was not corrected for High Pass Filter losses.
 5. Proper operation of the transmitter prior to adding the filter to the measurement chain.
 6. Owing to the highest peak level of unwanted emission out of the restricted bands are lower than the line(54dBuV/m) in the graph, so all the peak test point was deemed to comply with the limits -27dBm/MHz (68.2dBuV/m) list in the standard CFR 47 FCC §15.407 (b) and ISSED RSS-247 6.2.



HARMONICS AND SPURIOUS EMISSIONS (HIGH CHANNEL, HORIZONTAL)

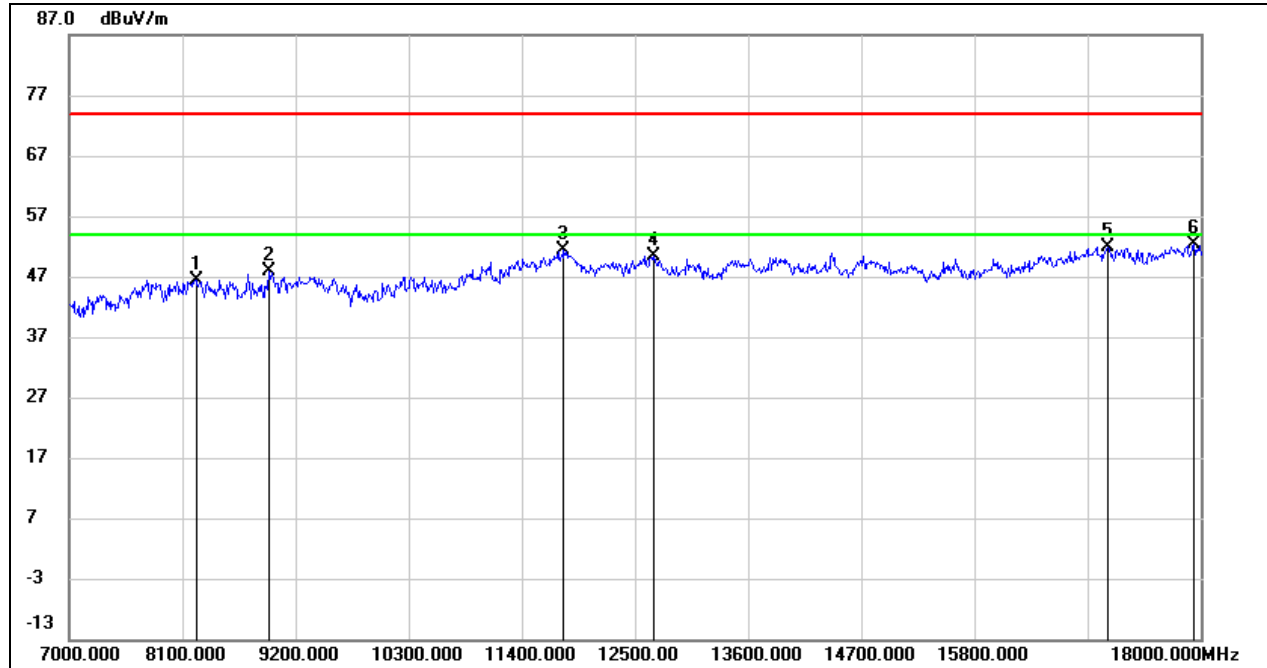

No.	Frequency (MHz)	Reading (dBuV)	Correct (dB/m)	Result (dBuV/m)	Limit (dBuV/m)	Margin (dB)	Remark
1	8232.000	37.09	9.23	46.32	74.00	-27.68	peak
2	8936.000	37.99	9.96	47.95	74.00	-26.05	peak
3	11807.000	35.79	15.61	51.40	74.00	-22.60	peak
4	12676.000	35.06	15.42	50.48	74.00	-23.52	peak
5	17098.000	31.33	20.63	51.96	74.00	-22.04	peak
6	17934.000	29.79	22.69	52.48	74.00	-21.52	peak

Note: 1. Measurement = Reading Level + Correct Factor.
 2. If Peak Result complies with AV limit, AV Result is deemed to comply with AV limit.
 3. Peak: Peak detector.
 4. Filter losses were only considered in the spurious frequency bands and the authorized band was not corrected for High Pass Filter losses.
 5. Proper operation of the transmitter prior to adding the filter to the measurement chain.
 6. Owing to the highest peak level of unwanted emission out of the restricted bands are lower than the line(54dBuV/m) in the graph, so all the peak test point was deemed to comply with the limits -27dBm/MHz (68.2dBuV/m) list in the standard CFR 47 FCC §15.407 (b) and ISED RSS-247 6.2.



HARMONICS AND SPURIOUS EMISSIONS (HIGH CHANNEL, VERTICAL)

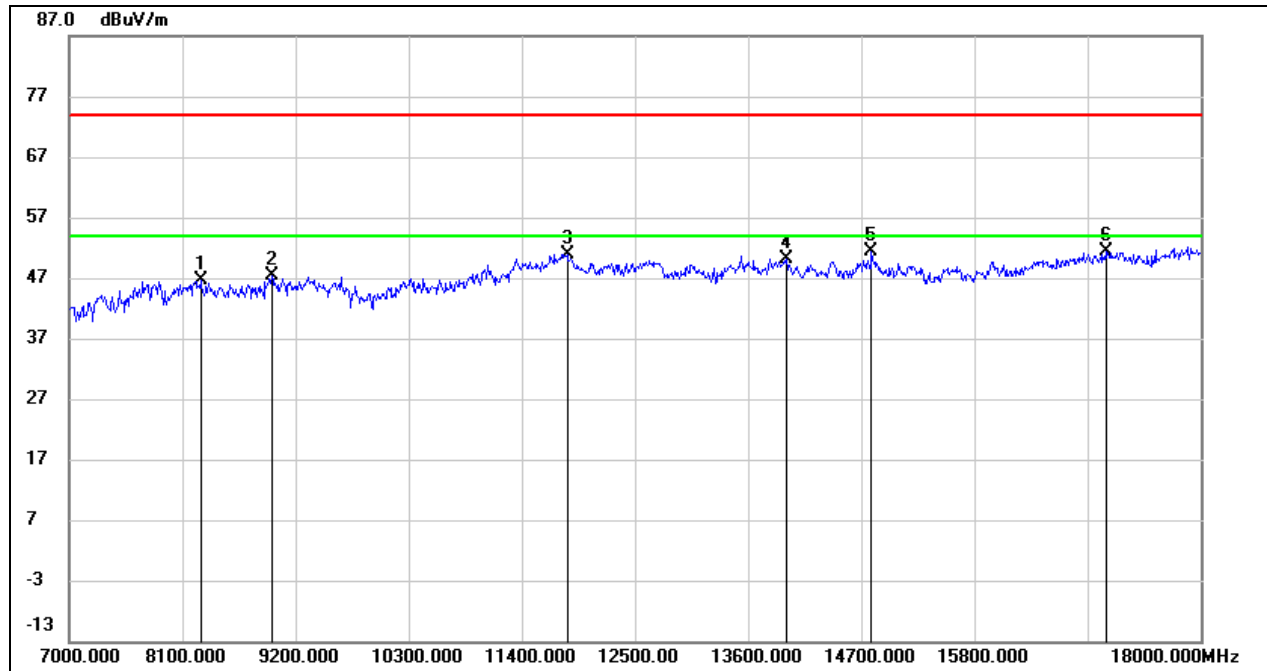

No.	Frequency (MHz)	Reading (dBuV)	Correct (dB/m)	Result (dBuV/m)	Limit (dBuV/m)	Margin (dB)	Remark
1	8276.000	37.66	9.06	46.72	74.00	-27.28	peak
2	8969.000	37.02	10.31	47.33	74.00	-26.67	peak
3	11840.000	35.30	15.56	50.86	74.00	-23.14	peak
4	13974.000	33.22	16.86	50.08	74.00	-23.92	peak
5	14799.000	34.51	16.80	51.31	74.00	-22.69	peak
6	17076.000	30.82	20.54	51.36	74.00	-22.64	peak

Note: 1. Measurement = Reading Level + Correct Factor.
 2. If Peak Result complies with AV limit, AV Result is deemed to comply with AV limit.
 3. Peak: Peak detector.
 4. Filter losses were only considered in the spurious frequency bands and the authorized band was not corrected for High Pass Filter losses.
 5. Proper operation of the transmitter prior to adding the filter to the measurement chain.
 6. Owing to the highest peak level of unwanted emission out of the restricted bands are lower than the line(54dBuV/m) in the graph, so all the peak test point was deemed to comply with the limits -27dBm/MHz (68.2dBuV/m) list in the standard CFR 47 FCC §15.407 (b) and ISED RSS-247 6.2.



UNII-2C BAND

HARMONICS AND SPURIOUS EMISSIONS (LOW CHANNEL, HORIZONTAL)

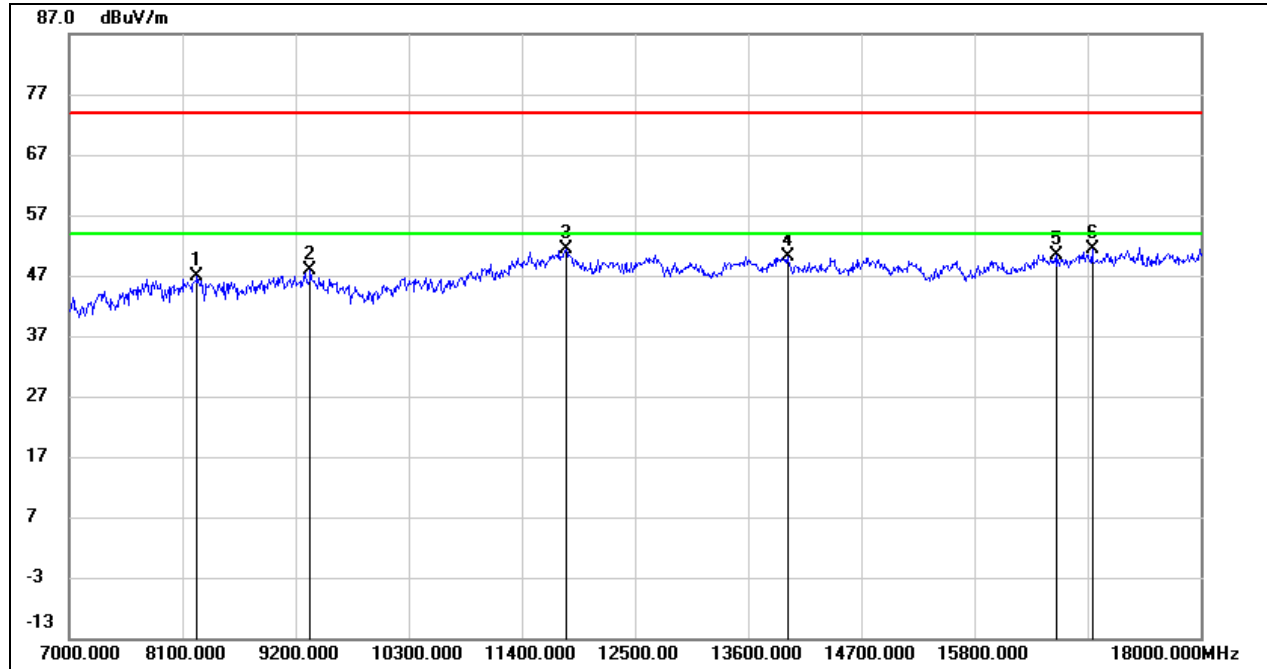

No.	Frequency (MHz)	Reading (dBuV)	Correct (dB/m)	Result (dBuV/m)	Limit (dBuV/m)	Margin (dB)	Remark
1	8243.000	37.66	9.19	46.85	74.00	-27.15	peak
2	9343.000	37.74	10.02	47.76	74.00	-26.24	peak
3	11829.000	35.72	15.57	51.29	74.00	-22.71	peak
4	13985.000	33.21	16.86	50.07	74.00	-23.93	peak
5	16603.000	30.94	19.54	50.48	74.00	-23.52	peak
6	16944.000	31.24	20.10	51.34	74.00	-22.66	peak

Note: 1. Measurement = Reading Level + Correct Factor.
 2. If Peak Result complies with AV limit, AV Result is deemed to comply with AV limit.
 3. Peak: Peak detector.
 4. Filter losses were only considered in the spurious frequency bands and the authorized band was not corrected for High Pass Filter losses.
 5. Proper operation of the transmitter prior to adding the filter to the measurement chain.
 6. Owing to the highest peak level of unwanted emission out of the restricted bands are lower than the line(54dBuV/m) in the graph, so all the peak test point was deemed to comply with the limits -27dBm/MHz (68.2dBuV/m) list in the standard CFR 47 FCC §15.407 (b) and ISED RSS-247 6.2.

HARMONICS AND SPURIOUS EMISSIONS (LOW CHANNEL, VERTICAL)

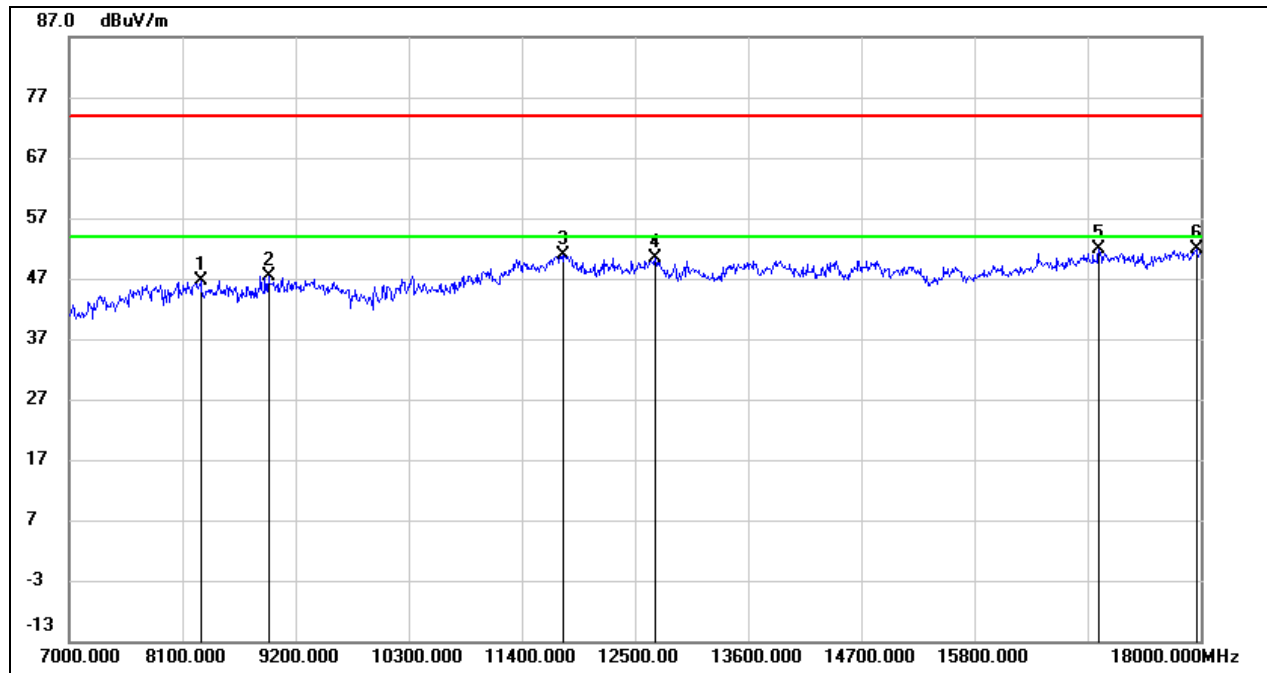

No.	Frequency (MHz)	Reading (dBuV)	Correct (dB/m)	Result (dBuV/m)	Limit (dBuV/m)	Margin (dB)	Remark
1	8276.000	37.61	9.06	46.67	74.00	-27.33	peak
2	8936.000	37.53	9.96	47.49	74.00	-26.51	peak
3	11807.000	35.28	15.61	50.89	74.00	-23.11	peak
4	12698.000	35.00	15.47	50.47	74.00	-23.53	peak
5	17010.000	31.64	20.27	51.91	74.00	-22.09	peak
6	17956.000	29.14	22.68	51.82	74.00	-22.18	peak

Note: 1. Measurement = Reading Level + Correct Factor.
 2. If Peak Result complies with AV limit, AV Result is deemed to comply with AV limit.
 3. Peak: Peak detector.
 4. Filter losses were only considered in the spurious frequency bands and the authorized band was not corrected for High Pass Filter losses.
 5. Proper operation of the transmitter prior to adding the filter to the measurement chain.
 6. Owing to the highest peak level of unwanted emission out of the restricted bands are lower than the line(54dBuV/m) in the graph, so all the peak test point was deemed to comply with the limits -27dBm/MHz (68.2dBuV/m) list in the standard CFR 47 FCC §15.407 (b) and ISED RSS-247 6.2.

HARMONICS AND SPURIOUS EMISSIONS (MID CHANNEL, HORIZONTAL)

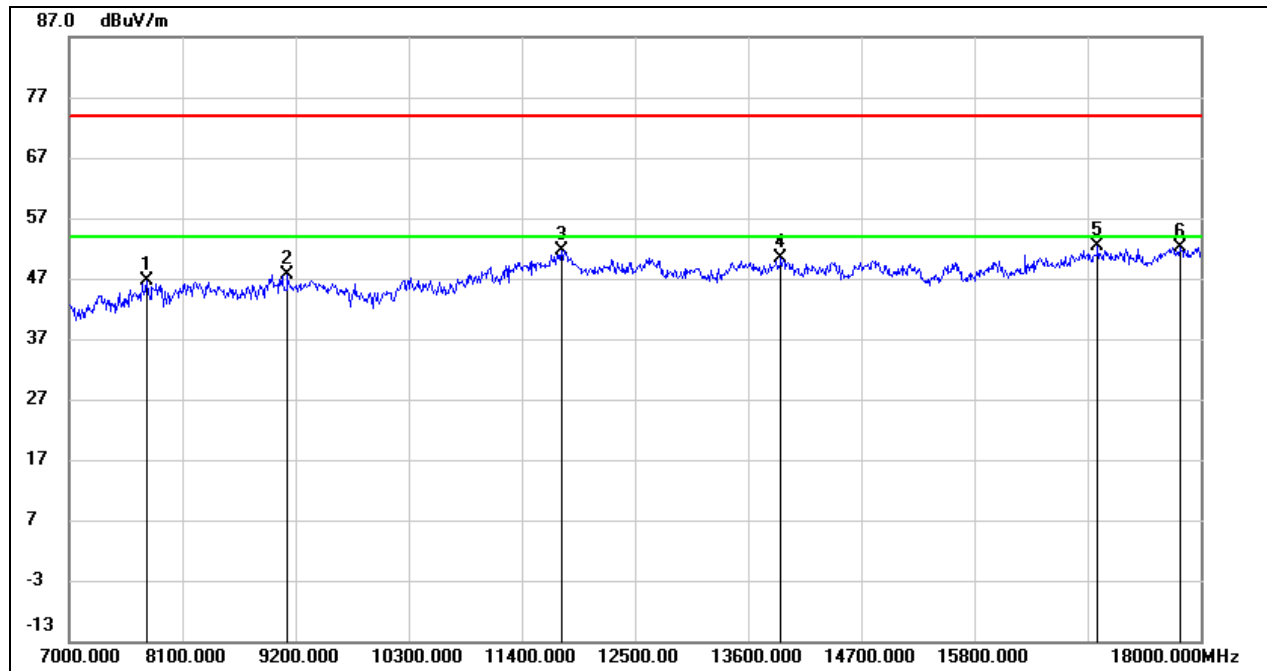

No.	Frequency (MHz)	Reading (dBuV)	Correct (dB/m)	Result (dBuV/m)	Limit (dBuV/m)	Margin (dB)	Remark
1	7748.000	38.70	8.05	46.75	74.00	-27.25	peak
2	9123.000	37.94	9.81	47.75	74.00	-26.25	peak
3	11785.000	36.00	15.52	51.52	74.00	-22.48	peak
4	13919.000	33.41	16.89	50.30	74.00	-23.70	peak
5	16999.000	32.19	20.23	52.42	74.00	-21.58	peak
6	17802.000	29.45	22.72	52.17	74.00	-21.83	peak

Note: 1. Measurement = Reading Level + Correct Factor.
 2. If Peak Result complies with AV limit, AV Result is deemed to comply with AV limit.
 3. Peak: Peak detector.
 4. Filter losses were only considered in the spurious frequency bands and the authorized band was not corrected for High Pass Filter losses.
 5. Proper operation of the transmitter prior to adding the filter to the measurement chain.
 6. Owing to the highest peak level of unwanted emission out of the restricted bands are lower than the line(54dBuV/m) in the graph, so all the peak test point was deemed to comply with the limits -27dBm/MHz (68.2dBuV/m) list in the standard CFR 47 FCC §15.407 (b) and ISED RSS-247 6.2.



HARMONICS AND SPURIOUS EMISSIONS (MID CHANNEL, VERTICAL)

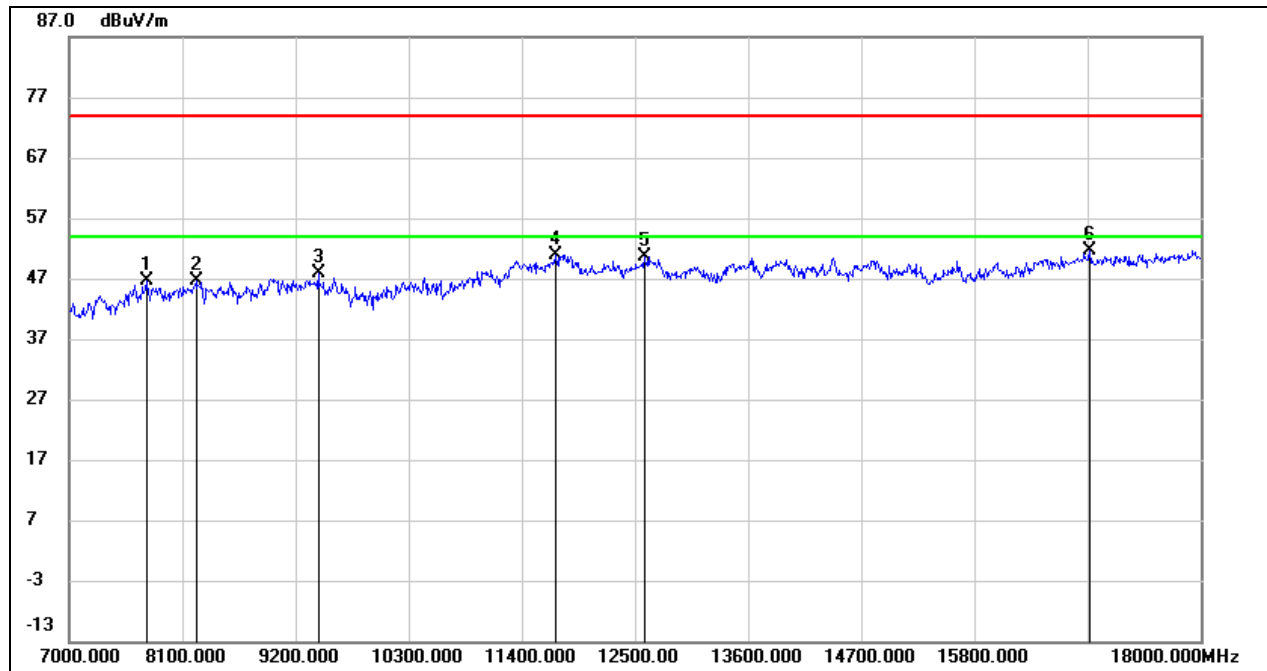

No.	Frequency (MHz)	Reading (dBuV)	Correct (dB/m)	Result (dBuV/m)	Limit (dBuV/m)	Margin (dB)	Remark
1	7748.000	38.51	8.05	46.56	74.00	-27.44	peak
2	8232.000	37.36	9.23	46.59	74.00	-27.41	peak
3	9420.000	37.57	10.34	47.91	74.00	-26.09	peak
4	11730.000	35.73	15.23	50.96	74.00	-23.04	peak
5	12588.000	35.37	15.29	50.66	74.00	-23.34	peak
6	16922.000	31.49	20.04	51.53	74.00	-22.47	peak

Note: 1. Measurement = Reading Level + Correct Factor.
 2. If Peak Result complies with AV limit, AV Result is deemed to comply with AV limit.
 3. Peak: Peak detector.
 4. Filter losses were only considered in the spurious frequency bands and the authorized band was not corrected for High Pass Filter losses.
 5. Proper operation of the transmitter prior to adding the filter to the measurement chain.
 6. Owing to the highest peak level of unwanted emission out of the restricted bands are lower than the line(54dBuV/m) in the graph, so all the peak test point was deemed to comply with the limits -27dBm/MHz (68.2dBuV/m) list in the standard CFR 47 FCC §15.407 (b) and ISED RSS-247 6.2.

HARMONICS AND SPURIOUS EMISSIONS (HIGH CHANNEL, HORIZONTAL)

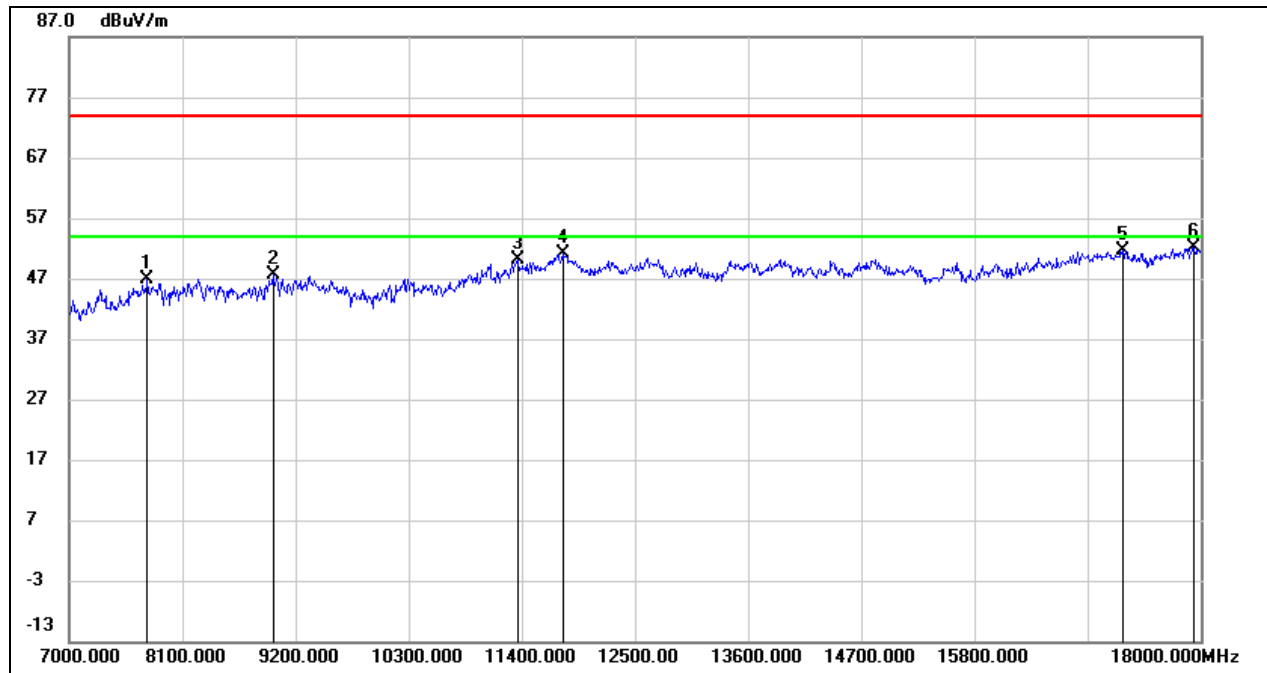

No.	Frequency (MHz)	Reading (dBuV)	Correct (dB/m)	Result (dBuV/m)	Limit (dBuV/m)	Margin (dB)	Remark
1	7759.000	38.68	8.09	46.77	74.00	-27.23	peak
2	8980.000	37.27	10.41	47.68	74.00	-26.32	peak
3	11356.000	36.00	14.09	50.09	74.00	-23.91	peak
4	11796.000	35.48	15.59	51.07	74.00	-22.93	peak
5	17241.000	30.72	20.97	51.69	74.00	-22.31	peak
6	17934.000	29.49	22.69	52.18	74.00	-21.82	peak

Note: 1. Measurement = Reading Level + Correct Factor.
 2. If Peak Result complies with AV limit, AV Result is deemed to comply with AV limit.
 3. Peak: Peak detector.
 4. Filter losses were only considered in the spurious frequency bands and the authorized band was not corrected for High Pass Filter losses.
 5. Proper operation of the transmitter prior to adding the filter to the measurement chain.
 6. Owing to the highest peak level of unwanted emission out of the restricted bands are lower than the line(54dBuV/m) in the graph, so all the peak test point was deemed to comply with the limits -27dBm/MHz (68.2dBuV/m) list in the standard CFR 47 FCC §15.407 (b) and ISED RSS-247 6.2.



HARMONICS AND SPURIOUS EMISSIONS (HIGH CHANNEL, VERTICAL)

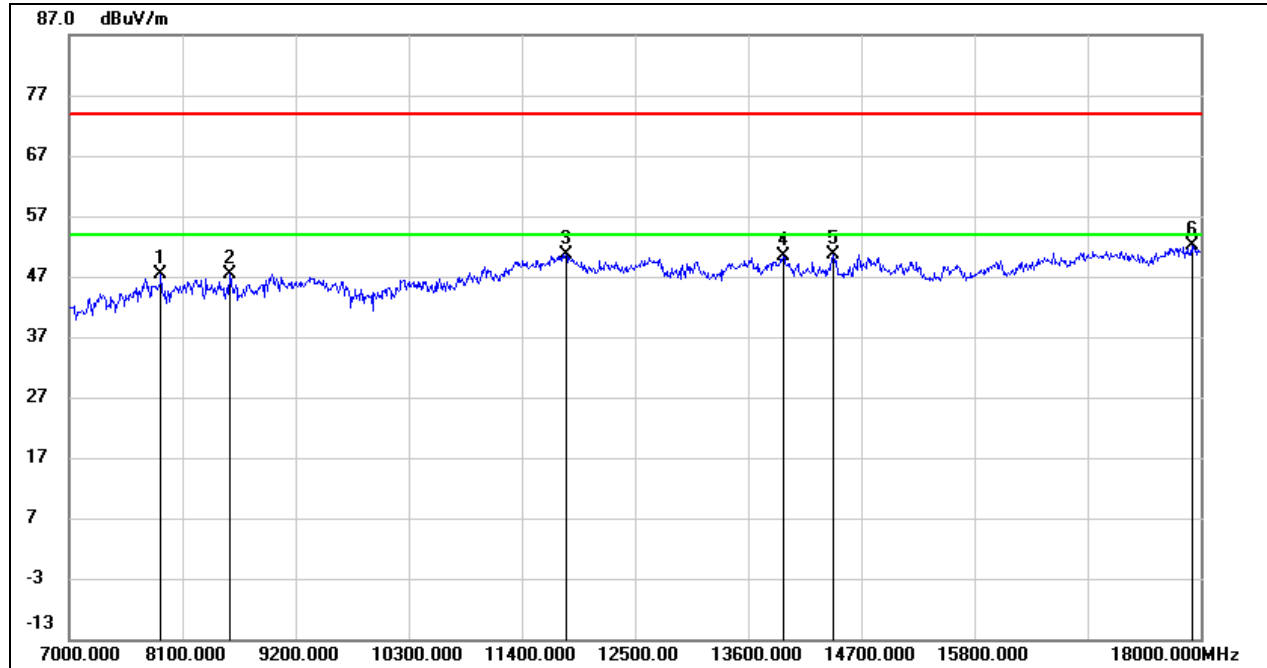

No.	Frequency (MHz)	Reading (dBuV)	Correct (dB/m)	Result (dBuV/m)	Limit (dBuV/m)	Margin (dB)	Remark
1	7891.000	39.31	7.98	47.29	74.00	-26.71	peak
2	8562.000	38.93	8.55	47.48	74.00	-26.52	peak
3	11829.000	35.12	15.57	50.69	74.00	-23.31	peak
4	13941.000	33.60	16.88	50.48	74.00	-23.52	peak
5	14425.000	33.80	16.80	50.60	74.00	-23.40	peak
6	17912.000	29.39	22.69	52.08	74.00	-21.92	peak

Note: 1. Measurement = Reading Level + Correct Factor.
 2. If Peak Result complies with AV limit, AV Result is deemed to comply with AV limit.
 3. Peak: Peak detector.
 4. Filter losses were only considered in the spurious frequency bands and the authorized band was not corrected for High Pass Filter losses.
 5. Proper operation of the transmitter prior to adding the filter to the measurement chain.
 6. Owing to the highest peak level of unwanted emission out of the restricted bands are lower than the line(54dBuV/m) in the graph, so all the peak test point was deemed to comply with the limits -27dBm/MHz (68.2dBuV/m) list in the standard CFR 47 FCC §15.407 (b) and ISED RSS-247 6.2.



STRADDLE CHANNEL 144

HARMONICS AND SPURIOUS EMISSIONS (HORIZONTAL)

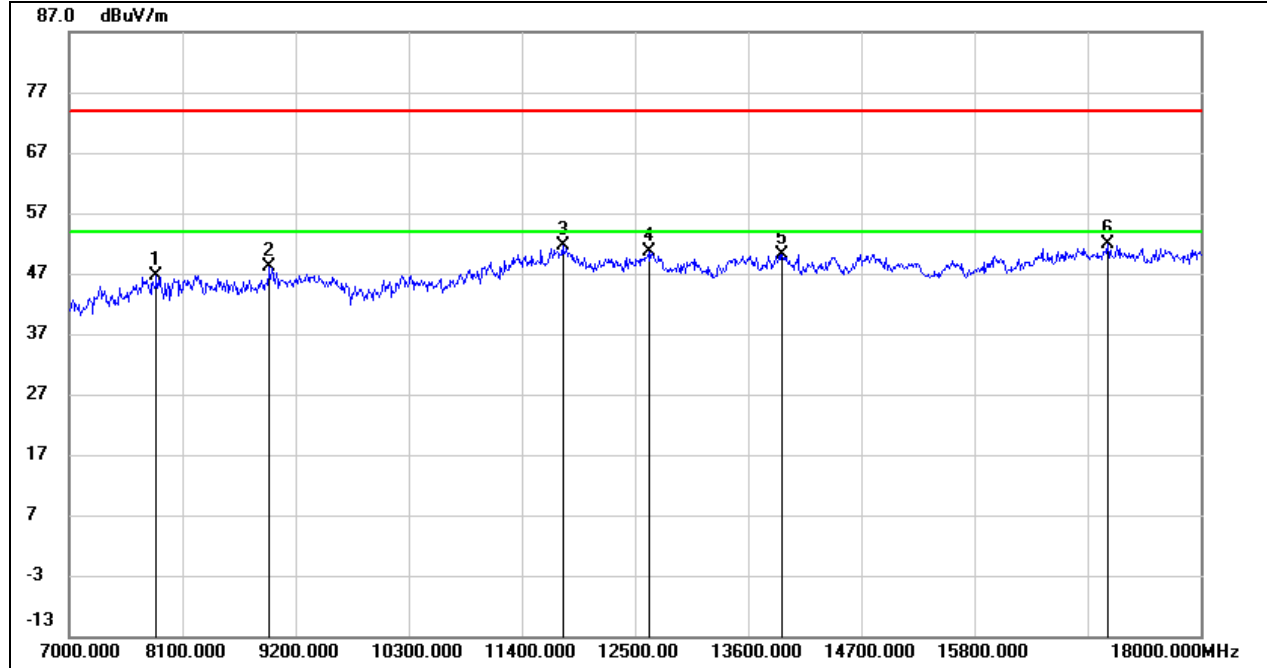

No.	Frequency (MHz)	Reading (dBuV)	Correct (dB/m)	Result (dBuV/m)	Limit (dBuV/m)	Margin (dB)	Remark
1	7847.000	38.59	8.11	46.70	74.00	-27.30	peak
2	8947.000	38.09	10.07	48.16	74.00	-25.84	peak
3	11796.000	35.98	15.59	51.57	74.00	-22.43	peak
4	12632.000	35.33	15.35	50.68	74.00	-23.32	peak
5	13930.000	33.28	16.89	50.17	74.00	-23.83	peak
6	17098.000	31.24	20.63	51.87	74.00	-22.13	peak

Note: 1. Measurement = Reading Level + Correct Factor.
 2. If Peak Result complies with AV limit, AV Result is deemed to comply with AV limit.
 3. Peak: Peak detector.
 4. Filter losses were only considered in the spurious frequency bands and the authorized band was not corrected for High Pass Filter losses.
 5. Proper operation of the transmitter prior to adding the filter to the measurement chain.
 6. Owing to the highest peak level of unwanted emission out of the restricted bands are lower than the line(54dBuV/m) in the graph, so all the peak test point was deemed to comply with the limits -27dBm/MHz (68.2dBuV/m) list in the standard CFR 47 FCC §15.407 (b) and ISED RSS-247 6.2.



HARMONICS AND SPURIOUS EMISSIONS (VERTICAL)

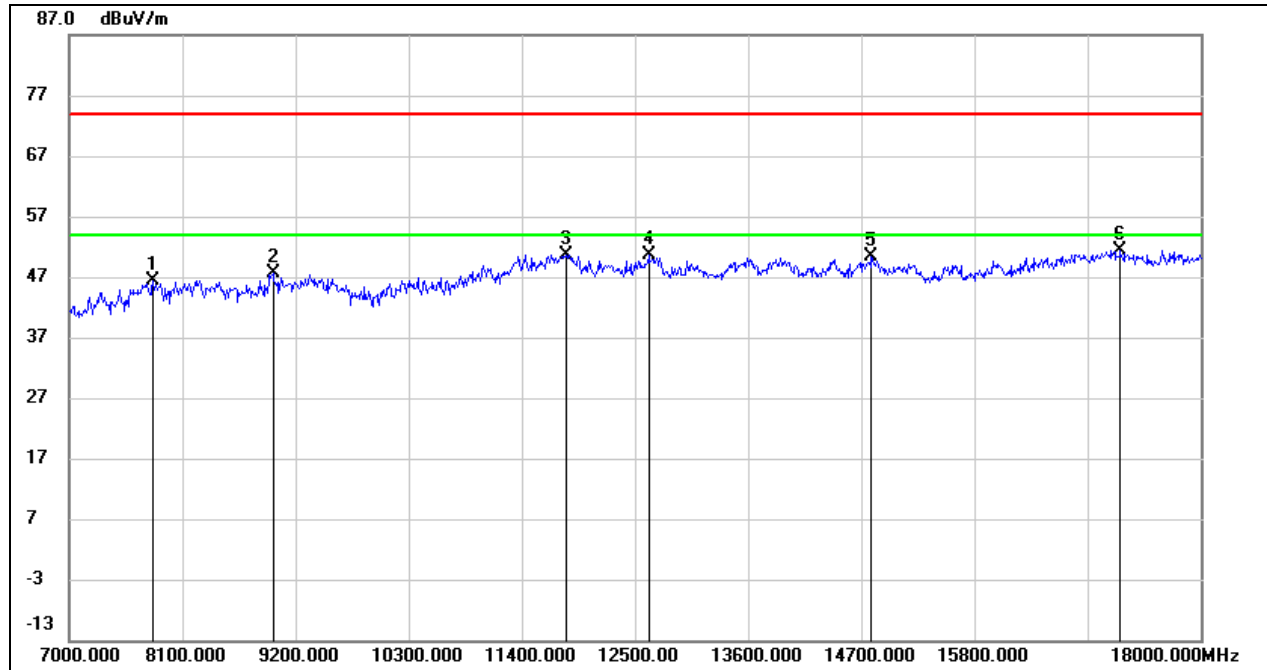

No.	Frequency (MHz)	Reading (dBuV)	Correct (dB/m)	Result (dBuV/m)	Limit (dBuV/m)	Margin (dB)	Remark
1	7814.000	38.28	8.21	46.49	74.00	-27.51	peak
2	8980.000	37.13	10.41	47.54	74.00	-26.46	peak
3	11829.000	35.15	15.57	50.72	74.00	-23.28	peak
4	12632.000	35.21	15.35	50.56	74.00	-23.44	peak
5	14799.000	33.48	16.80	50.28	74.00	-23.72	peak
6	17219.000	30.46	21.01	51.47	74.00	-22.53	peak

Note: 1. Measurement = Reading Level + Correct Factor.
 2. If Peak Result complies with AV limit, AV Result is deemed to comply with AV limit.
 3. Peak: Peak detector.
 4. Filter losses were only considered in the spurious frequency bands and the authorized band was not corrected for High Pass Filter losses.
 5. Proper operation of the transmitter prior to adding the filter to the measurement chain.
 6. Owing to the highest peak level of unwanted emission out of the restricted bands are lower than the line(54dBuV/m) in the graph, so all the peak test point was deemed to comply with the limits -27dBm/MHz (68.2dBuV/m) list in the standard CFR 47 FCC §15.407 (b) and ISSED RSS-247 6.2.



UNII-3 BAND

HARMONICS AND SPURIOUS EMISSIONS (LOW CHANNEL, HORIZONTAL)

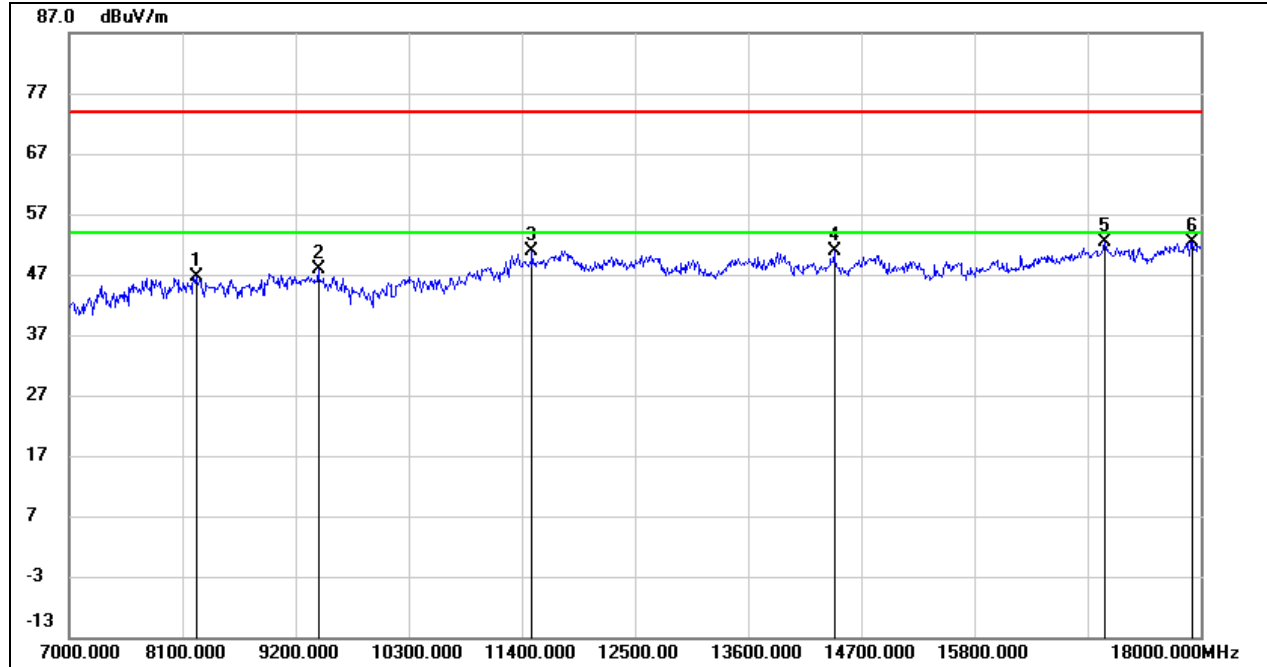

No.	Frequency (MHz)	Reading (dBuV)	Correct (dB/m)	Result (dBuV/m)	Limit (dBuV/m)	Margin (dB)	Remark
1	8232.000	37.48	9.23	46.71	74.00	-27.29	peak
2	9420.000	37.49	10.34	47.83	74.00	-26.17	peak
3	11499.000	36.62	14.36	50.98	74.00	-23.02	peak
4	14436.000	34.08	16.79	50.87	74.00	-23.13	peak
5	17065.000	31.80	20.49	52.29	74.00	-21.71	peak
6	17923.000	29.62	22.69	52.31	74.00	-21.69	peak

Note: 1. Measurement = Reading Level + Correct Factor.
 2. If Peak Result complies with AV limit, AV Result is deemed to comply with AV limit.
 3. Peak: Peak detector.
 4. Filter losses were only considered in the spurious frequency bands and the authorized band was not corrected for High Pass Filter losses.
 5. Proper operation of the transmitter prior to adding the filter to the measurement chain.
 6. Owing to the highest peak level of unwanted emission out of the restricted bands are lower than the line(54dBuV/m) in the graph, so all the peak test point was deemed to comply with the limits -27dBm/MHz (68.2dBuV/m) list in the standard CFR 47 FCC §15.407 (b) and ISSED RSS-247 6.2.

HARMONICS AND SPURIOUS EMISSIONS (LOW CHANNEL, VERTICAL)

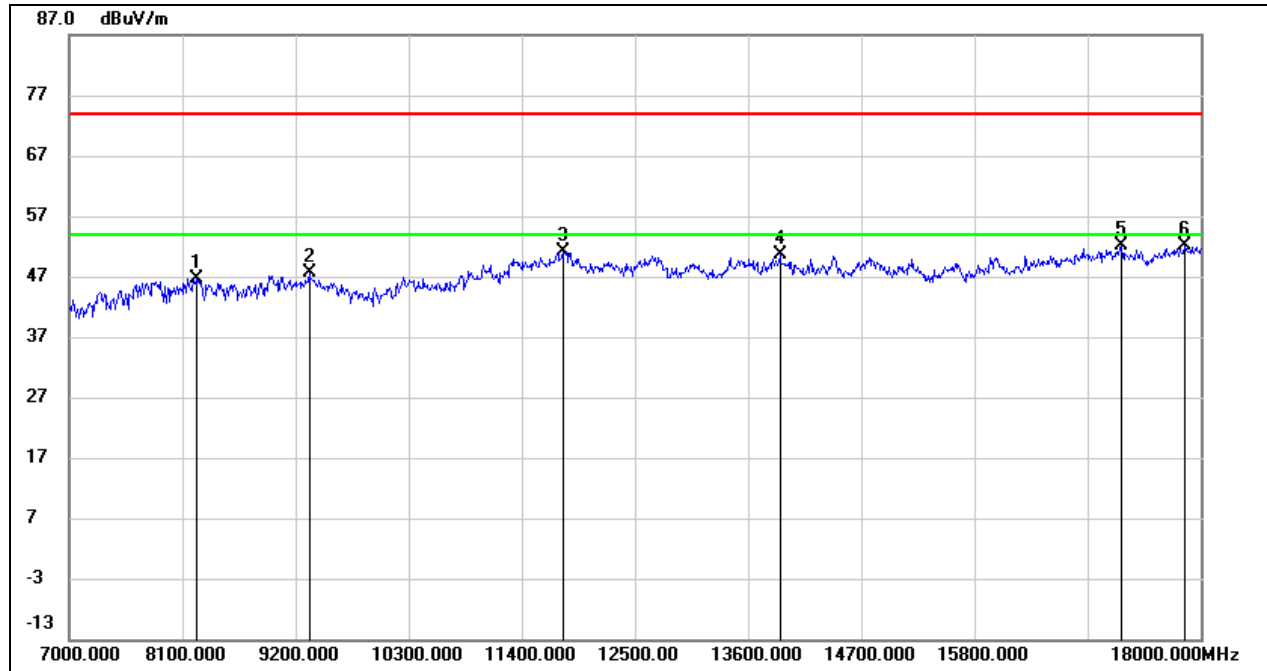

No.	Frequency (MHz)	Reading (dBuV)	Correct (dB/m)	Result (dBuV/m)	Limit (dBuV/m)	Margin (dB)	Remark
1	8232.000	37.49	9.23	46.72	74.00	-27.28	peak
2	9332.000	37.61	9.97	47.58	74.00	-26.42	peak
3	11796.000	35.63	15.59	51.22	74.00	-22.78	peak
4	13908.000	33.73	16.90	50.63	74.00	-23.37	peak
5	17230.000	31.09	20.99	52.08	74.00	-21.92	peak
6	17846.000	29.42	22.71	52.13	74.00	-21.87	peak

Note: 1. Measurement = Reading Level + Correct Factor.
 2. If Peak Result complies with AV limit, AV Result is deemed to comply with AV limit.
 3. Peak: Peak detector.
 4. Filter losses were only considered in the spurious frequency bands and the authorized band was not corrected for High Pass Filter losses.
 5. Proper operation of the transmitter prior to adding the filter to the measurement chain.
 6. Owing to the highest peak level of unwanted emission out of the restricted bands are lower than the line(54dBuV/m) in the graph, so all the peak test point was deemed to comply with the limits -27dBm/MHz (68.2dBuV/m) list in the standard CFR 47 FCC §15.407 (b) and ISED RSS-247 6.2.



HARMONICS AND SPURIOUS EMISSIONS (MID CHANNEL, HORIZONTAL)

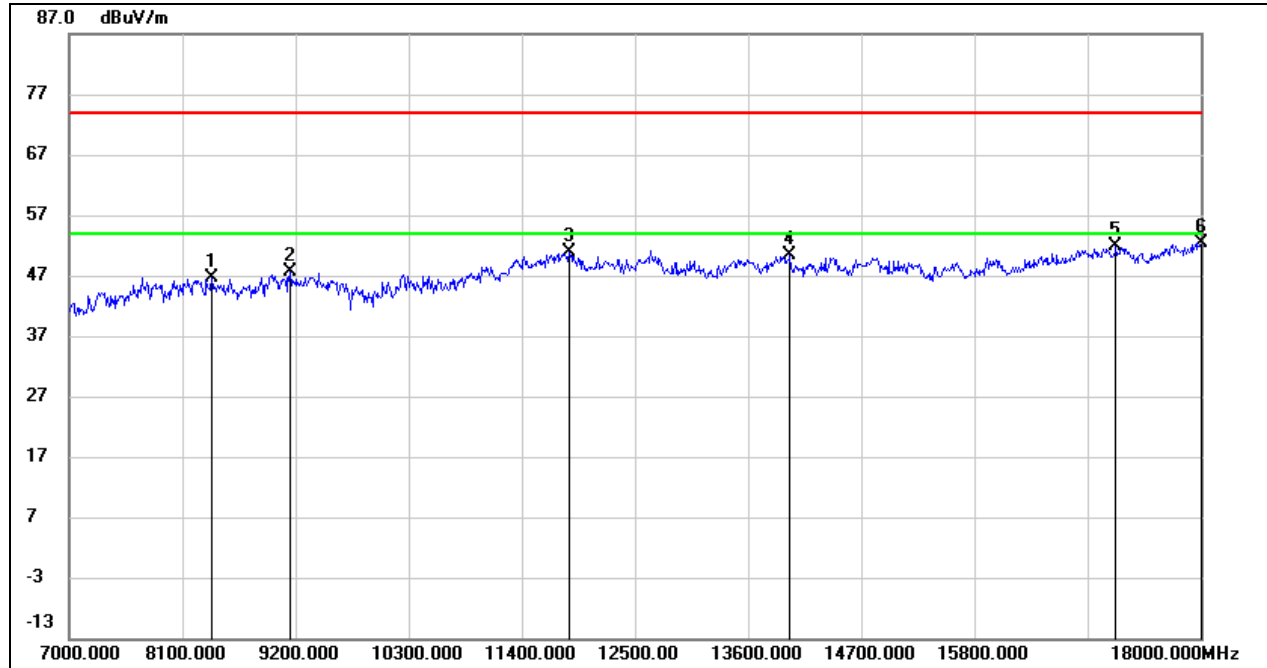

No.	Frequency (MHz)	Reading (dBuV)	Correct (dB/m)	Result (dBuV/m)	Limit (dBuV/m)	Margin (dB)	Remark
1	8386.000	38.10	8.64	46.74	74.00	-27.26	peak
2	9145.000	38.01	9.66	47.67	74.00	-26.33	peak
3	11862.000	35.37	15.52	50.89	74.00	-23.11	peak
4	14007.000	33.42	16.85	50.27	74.00	-23.73	peak
5	17175.000	30.99	20.94	51.93	74.00	-22.07	peak
6	18000.000	29.75	22.67	52.42	74.00	-21.58	peak

Note: 1. Measurement = Reading Level + Correct Factor.
 2. If Peak Result complies with AV limit, AV Result is deemed to comply with AV limit.
 3. Peak: Peak detector.
 4. Filter losses were only considered in the spurious frequency bands and the authorized band was not corrected for High Pass Filter losses.
 5. Proper operation of the transmitter prior to adding the filter to the measurement chain.
 6. Owing to the highest peak level of unwanted emission out of the restricted bands are lower than the line(54dBuV/m) in the graph, so all the peak test point was deemed to comply with the limits -27dBm/MHz (68.2dBuV/m) list in the standard CFR 47 FCC §15.407 (b) and ISED RSS-247 6.2.

HARMONICS AND SPURIOUS EMISSIONS (MID CHANNEL, VERTICAL)

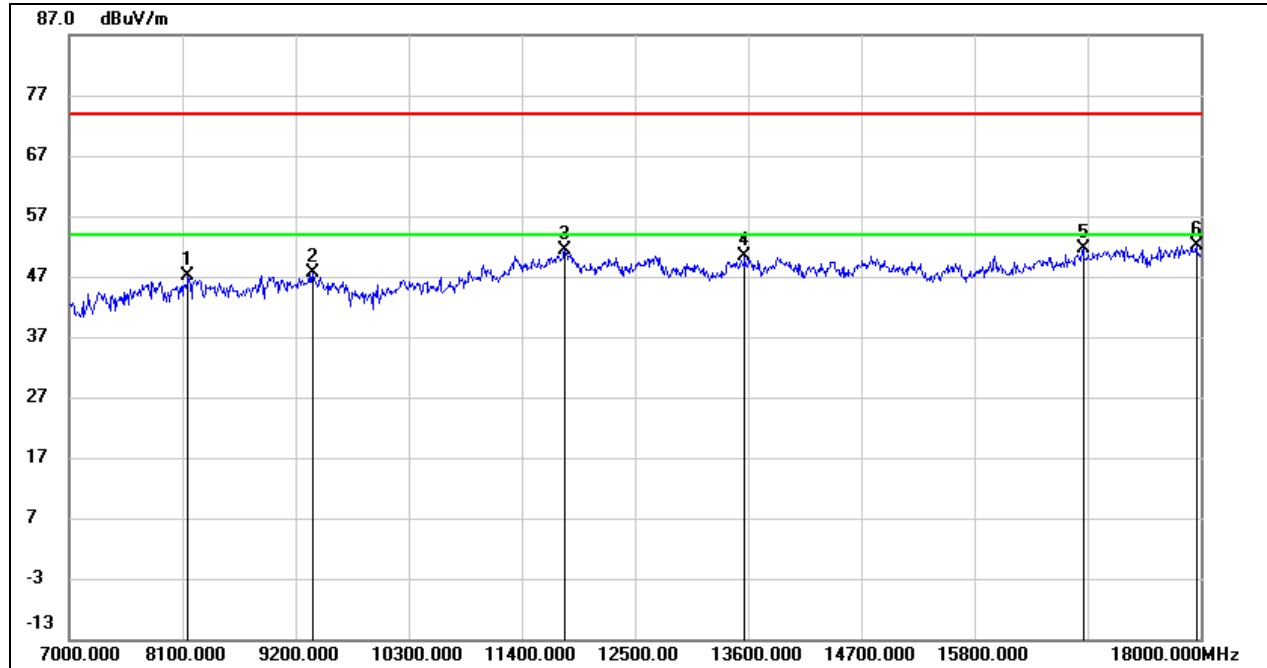

No.	Frequency (MHz)	Reading (dBuV)	Correct (dB/m)	Result (dBuV/m)	Limit (dBuV/m)	Margin (dB)	Remark
1	8155.000	38.04	8.98	47.02	74.00	-26.98	peak
2	9365.000	37.55	10.13	47.68	74.00	-26.32	peak
3	11818.000	35.87	15.58	51.45	74.00	-22.55	peak
4	13567.000	33.95	16.42	50.37	74.00	-23.63	peak
5	16856.000	31.83	19.87	51.70	74.00	-22.30	peak
6	17956.000	29.41	22.68	52.09	74.00	-21.91	peak

Note: 1. Measurement = Reading Level + Correct Factor.
 2. If Peak Result complies with AV limit, AV Result is deemed to comply with AV limit.
 3. Peak: Peak detector.
 4. Filter losses were only considered in the spurious frequency bands and the authorized band was not corrected for High Pass Filter losses.
 5. Proper operation of the transmitter prior to adding the filter to the measurement chain.
 6. Owing to the highest peak level of unwanted emission out of the restricted bands are lower than the line(54dBuV/m) in the graph, so all the peak test point was deemed to comply with the limits -27dBm/MHz (68.2dBuV/m) list in the standard CFR 47 FCC §15.407 (b) and ISED RSS-247 6.2.



HARMONICS AND SPURIOUS EMISSIONS (HIGH CHANNEL, HORIZONTAL)

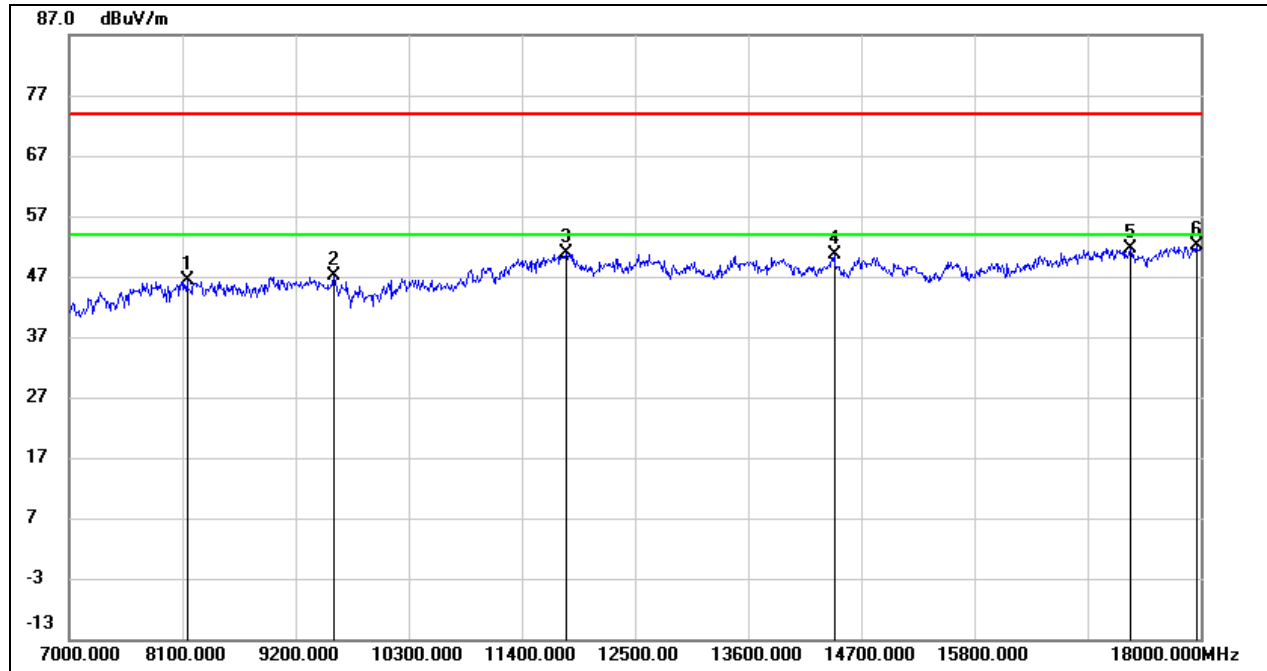

No.	Frequency (MHz)	Reading (dBuV)	Correct (dB/m)	Result (dBuV/m)	Limit (dBuV/m)	Margin (dB)	Remark
1	8144.000	37.52	8.88	46.40	74.00	-27.60	peak
2	9574.000	36.67	10.46	47.13	74.00	-26.87	peak
3	11829.000	35.39	15.57	50.96	74.00	-23.04	peak
4	14436.000	33.80	16.79	50.59	74.00	-23.41	peak
5	17318.000	30.75	20.86	51.61	74.00	-22.39	peak
6	17956.000	29.47	22.68	52.15	74.00	-21.85	peak

Note: 1. Measurement = Reading Level + Correct Factor.
 2. If Peak Result complies with AV limit, AV Result is deemed to comply with AV limit.
 3. Peak: Peak detector.
 4. Filter losses were only considered in the spurious frequency bands and the authorized band was not corrected for High Pass Filter losses.
 5. Proper operation of the transmitter prior to adding the filter to the measurement chain.
 6. Owing to the highest peak level of unwanted emission out of the restricted bands are lower than the line(54dBuV/m) in the graph, so all the peak test point was deemed to comply with the limits -27dBm/MHz (68.2dBuV/m) list in the standard CFR 47 FCC §15.407 (b) and ISED RSS-247 6.2.



HARMONICS AND SPURIOUS EMISSIONS (HIGH CHANNEL, VERTICAL)

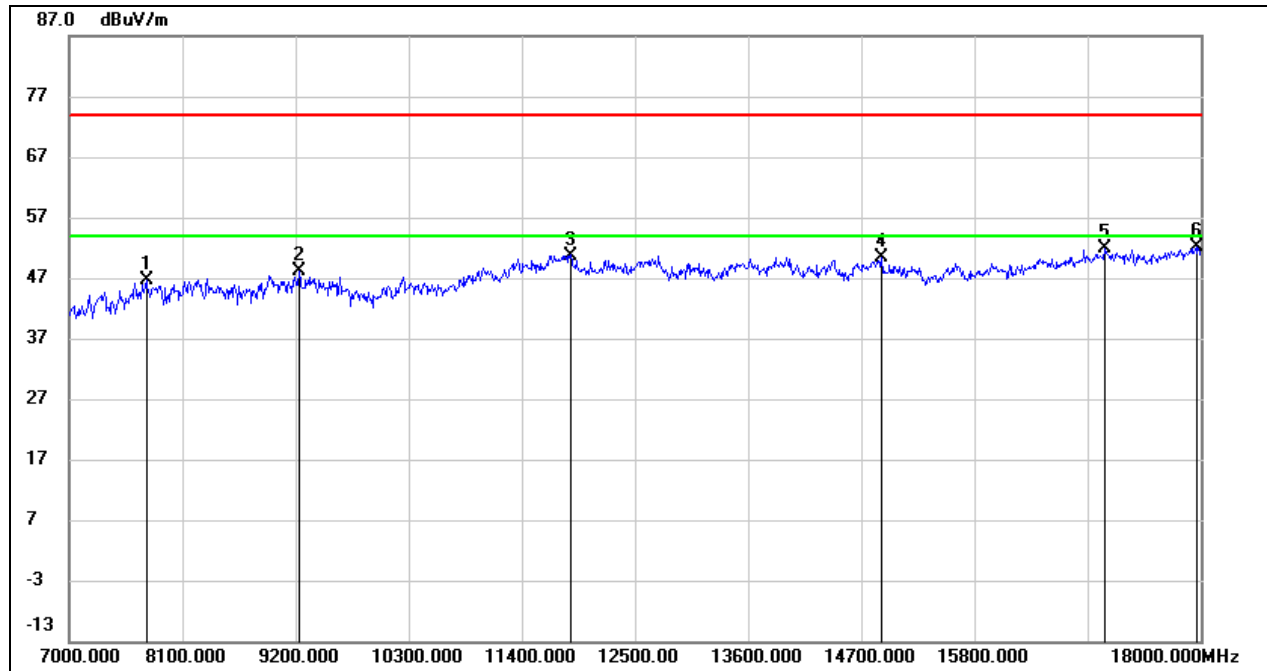

No.	Frequency (MHz)	Reading (dBuV)	Correct (dB/m)	Result (dBuV/m)	Limit (dBuV/m)	Margin (dB)	Remark
1	7748.000	38.56	8.05	46.61	74.00	-27.39	peak
2	9233.000	38.72	9.46	48.18	74.00	-25.82	peak
3	11873.000	35.25	15.50	50.75	74.00	-23.25	peak
4	14898.000	33.58	16.85	50.43	74.00	-23.57	peak
5	17065.000	31.27	20.49	51.76	74.00	-22.24	peak
6	17967.000	29.54	22.67	52.21	74.00	-21.79	peak

Note: 1. Measurement = Reading Level + Correct Factor.
 2. If Peak Result complies with AV limit, AV Result is deemed to comply with AV limit.
 3. Peak: Peak detector.
 4. Filter losses were only considered in the spurious frequency bands and the authorized band was not corrected for High Pass Filter losses.
 5. Proper operation of the transmitter prior to adding the filter to the measurement chain.
 6. Owing to the highest peak level of unwanted emission out of the restricted bands are lower than the line(54dBuV/m) in the graph, so all the peak test point was deemed to comply with the limits -27dBm/MHz (68.2dBuV/m) list in the standard CFR 47 FCC §15.407 (b) and ISED RSS-247 6.2.



8.3.3. 802.11ac VHT40 MIMO MODE

UNII-1 BAND

HARMONICS AND SPURIOUS EMISSIONS (LOW CHANNEL, HORIZONTAL)

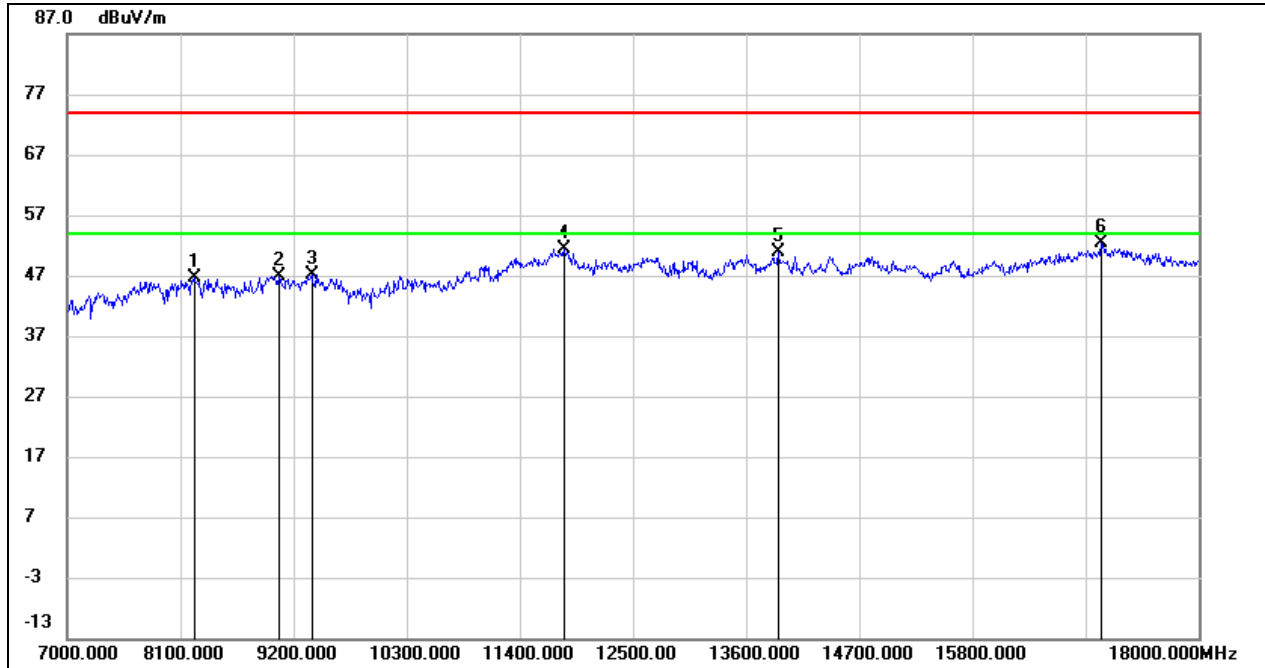

No.	Frequency (MHz)	Reading (dBuV)	Correct (dB/m)	Result (dBuV/m)	Limit (dBuV/m)	Margin (dB)	Remark
1	8232.000	37.36	9.23	46.59	74.00	-27.41	peak
2	9057.000	36.69	10.26	46.95	74.00	-27.05	peak
3	9376.000	37.02	10.19	47.21	74.00	-26.79	peak
4	11829.000	35.84	15.57	51.41	74.00	-22.59	peak
5	13908.000	33.87	16.90	50.77	74.00	-23.23	peak
6	17054.000	31.87	20.45	52.32	74.00	-21.68	peak

Note: 1. Measurement = Reading Level + Correct Factor.
 2. If Peak Result complies with AV limit, AV Result is deemed to comply with AV limit.
 3. Peak: Peak detector.
 4. Filter losses were only considered in the spurious frequency bands and the authorized band was not corrected for High Pass Filter losses.
 5. Proper operation of the transmitter prior to adding the filter to the measurement chain.
 6. Owing to the highest peak level of unwanted emission out of the restricted bands are lower than the line(54dBuV/m) in the graph, so all the peak test point was deemed to comply with the limits -27dBm/MHz (68.2dBuV/m) list in the standard CFR 47 FCC §15.407 (b) and ISED RSS-247 6.2.

HARMONICS AND SPURIOUS EMISSIONS (LOW CHANNEL, VERTICAL)

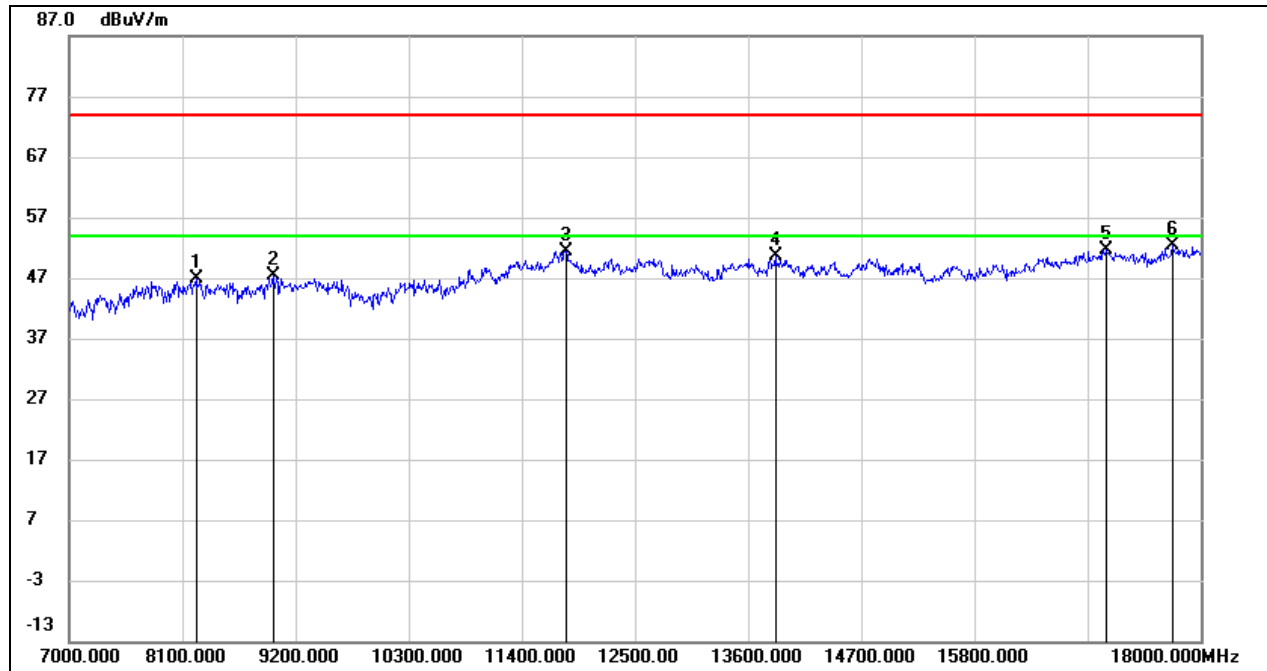

No.	Frequency (MHz)	Reading (dBuV)	Correct (dB/m)	Result (dBuV/m)	Limit (dBuV/m)	Margin (dB)	Remark
1	8232.000	37.59	9.23	46.82	74.00	-27.18	peak
2	8980.000	36.95	10.41	47.36	74.00	-26.64	peak
3	11829.000	35.86	15.57	51.43	74.00	-22.57	peak
4	13864.000	33.76	16.92	50.68	74.00	-23.32	peak
5	17087.000	31.15	20.58	51.73	74.00	-22.27	peak
6	17725.000	30.25	22.13	52.38	74.00	-21.62	peak

Note: 1. Measurement = Reading Level + Correct Factor.
 2. If Peak Result complies with AV limit, AV Result is deemed to comply with AV limit.
 3. Peak: Peak detector.
 4. Filter losses were only considered in the spurious frequency bands and the authorized band was not corrected for High Pass Filter losses.
 5. Proper operation of the transmitter prior to adding the filter to the measurement chain.
 6. Owing to the highest peak level of unwanted emission out of the restricted bands are lower than the line(54dBuV/m) in the graph, so all the peak test point was deemed to comply with the limits -27dBm/MHz (68.2dBuV/m) list in the standard CFR 47 FCC §15.407 (b) and ISED RSS-247 6.2.

HARMONICS AND SPURIOUS EMISSIONS (HIGH CHANNEL, HORIZONTAL)

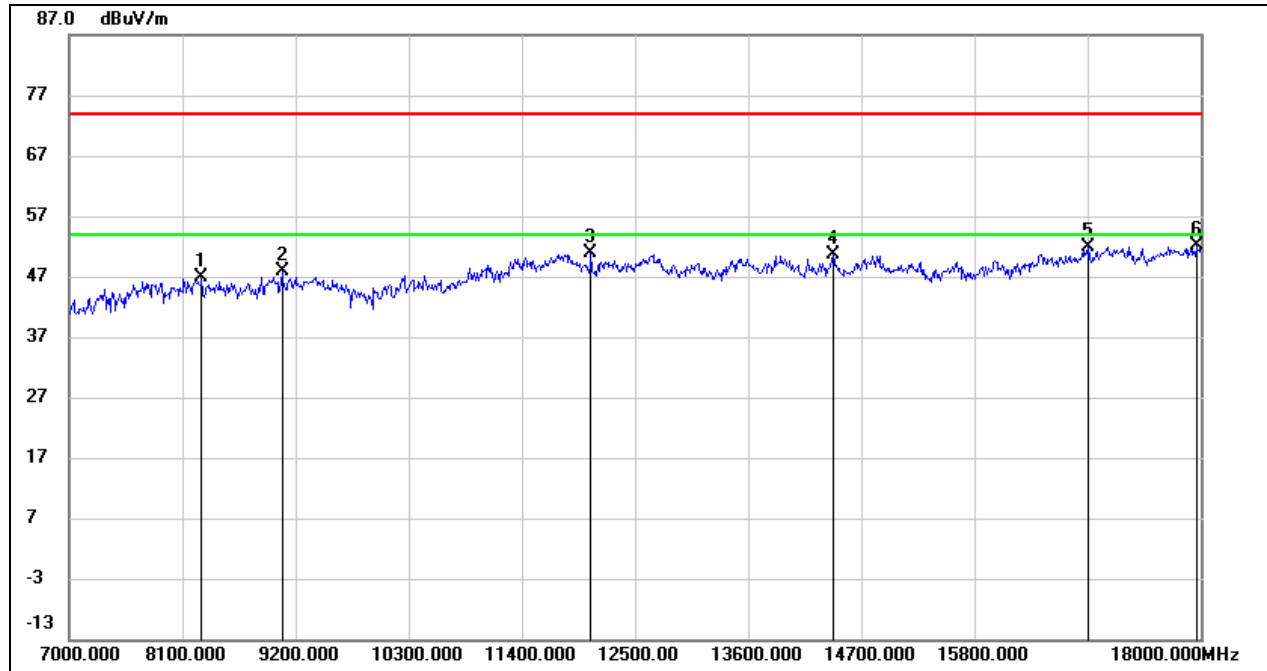

No.	Frequency (MHz)	Reading (dBuV)	Correct (dB/m)	Result (dBuV/m)	Limit (dBuV/m)	Margin (dB)	Remark
1	8287.000	37.92	9.02	46.94	74.00	-27.06	peak
2	9068.000	37.68	10.17	47.85	74.00	-26.15	peak
3	12071.000	35.65	15.24	50.89	74.00	-23.11	peak
4	14425.000	33.72	16.80	50.52	74.00	-23.48	peak
5	16911.000	31.87	20.02	51.89	74.00	-22.11	peak
6	17956.000	29.54	22.68	52.22	74.00	-21.78	peak

Note: 1. Measurement = Reading Level + Correct Factor.
 2. If Peak Result complies with AV limit, AV Result is deemed to comply with AV limit.
 3. Peak: Peak detector.
 4. Filter losses were only considered in the spurious frequency bands and the authorized band was not corrected for High Pass Filter losses.
 5. Proper operation of the transmitter prior to adding the filter to the measurement chain.
 6. Owing to the highest peak level of unwanted emission out of the restricted bands are lower than the line(54dBuV/m) in the graph, so all the peak test point was deemed to comply with the limits -27dBm/MHz (68.2dBuV/m) list in the standard CFR 47 FCC §15.407 (b) and ISED RSS-247 6.2.



HARMONICS AND SPURIOUS EMISSIONS (HIGH CHANNEL, VERTICAL)

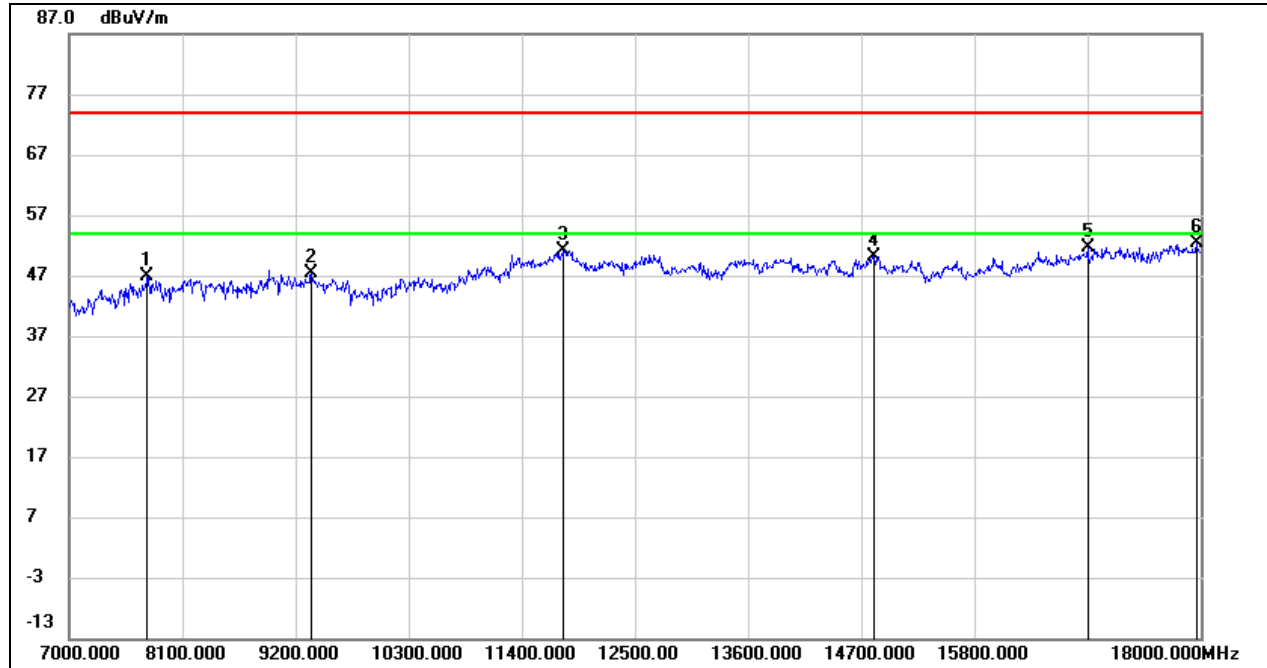

No.	Frequency (MHz)	Reading (dBuV)	Correct (dB/m)	Result (dBuV/m)	Limit (dBuV/m)	Margin (dB)	Remark
1	7759.000	38.67	8.09	46.76	74.00	-27.24	peak
2	9354.000	37.32	10.07	47.39	74.00	-26.61	peak
3	11807.000	35.61	15.61	51.22	74.00	-22.78	peak
4	14821.000	33.39	16.81	50.20	74.00	-23.80	peak
5	16900.000	31.74	19.98	51.72	74.00	-22.28	peak
6	17956.000	29.76	22.68	52.44	74.00	-21.56	peak

Note: 1. Measurement = Reading Level + Correct Factor.
 2. If Peak Result complies with AV limit, AV Result is deemed to comply with AV limit.
 3. Peak: Peak detector.
 4. Filter losses were only considered in the spurious frequency bands and the authorized band was not corrected for High Pass Filter losses.
 5. Proper operation of the transmitter prior to adding the filter to the measurement chain.
 6. Owing to the highest peak level of unwanted emission out of the restricted bands are lower than the line(54dBuV/m) in the graph, so all the peak test point was deemed to comply with the limits -27dBm/MHz (68.2dBuV/m) list in the standard CFR 47 FCC §15.407 (b) and ISED RSS-247 6.2.



UNII-2A BAND

HARMONICS AND SPURIOUS EMISSIONS (LOW CHANNEL, HORIZONTAL)

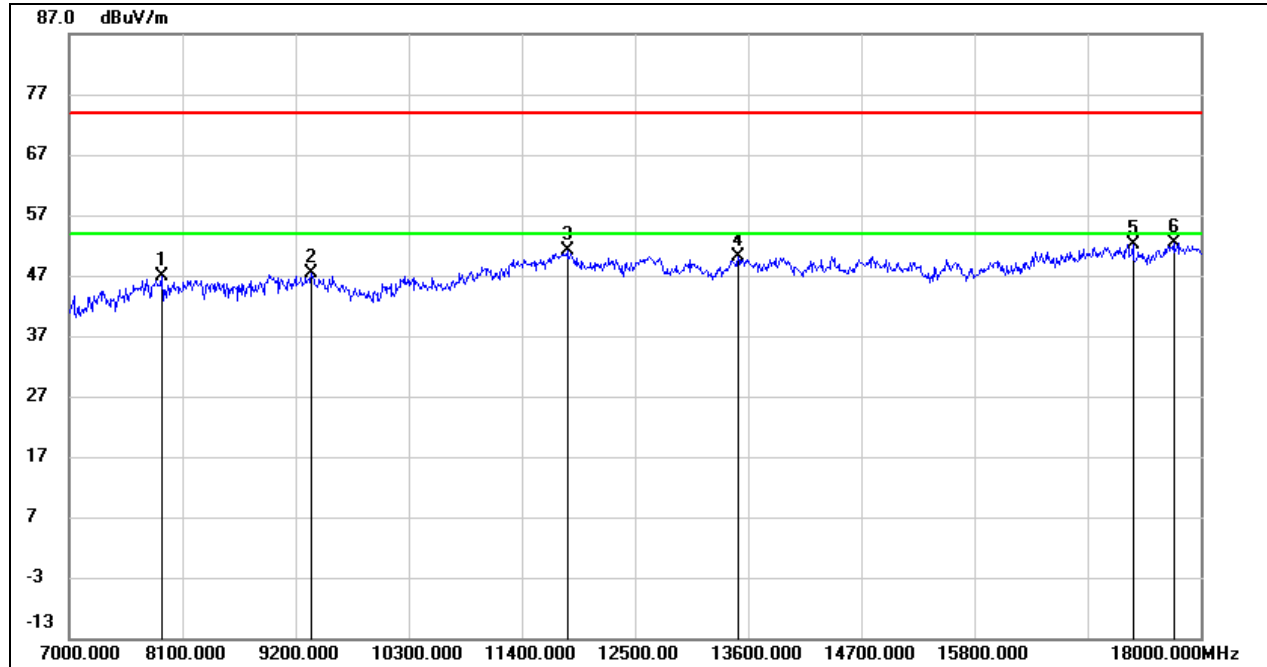

No.	Frequency (MHz)	Reading (dBuV)	Correct (dB/m)	Result (dBuV/m)	Limit (dBuV/m)	Margin (dB)	Remark
1	7902.000	38.96	7.95	46.91	74.00	-27.09	peak
2	9354.000	37.19	10.07	47.26	74.00	-26.74	peak
3	11840.000	35.47	15.56	51.03	74.00	-22.97	peak
4	13501.000	33.79	16.41	50.20	74.00	-23.80	peak
5	17340.000	31.23	20.82	52.05	74.00	-21.95	peak
6	17736.000	30.10	22.22	52.32	74.00	-21.68	peak

Note: 1. Measurement = Reading Level + Correct Factor.
 2. If Peak Result complies with AV limit, AV Result is deemed to comply with AV limit.
 3. Peak: Peak detector.
 4. Filter losses were only considered in the spurious frequency bands and the authorized band was not corrected for High Pass Filter losses.
 5. Proper operation of the transmitter prior to adding the filter to the measurement chain.
 6. Owing to the highest peak level of unwanted emission out of the restricted bands are lower than the line(54dBuV/m) in the graph, so all the peak test point was deemed to comply with the limits -27dBm/MHz (68.2dBuV/m) list in the standard CFR 47 FCC §15.407 (b) and ISED RSS-247 6.2.



HARMONICS AND SPURIOUS EMISSIONS (LOW CHANNEL, VERTICAL)

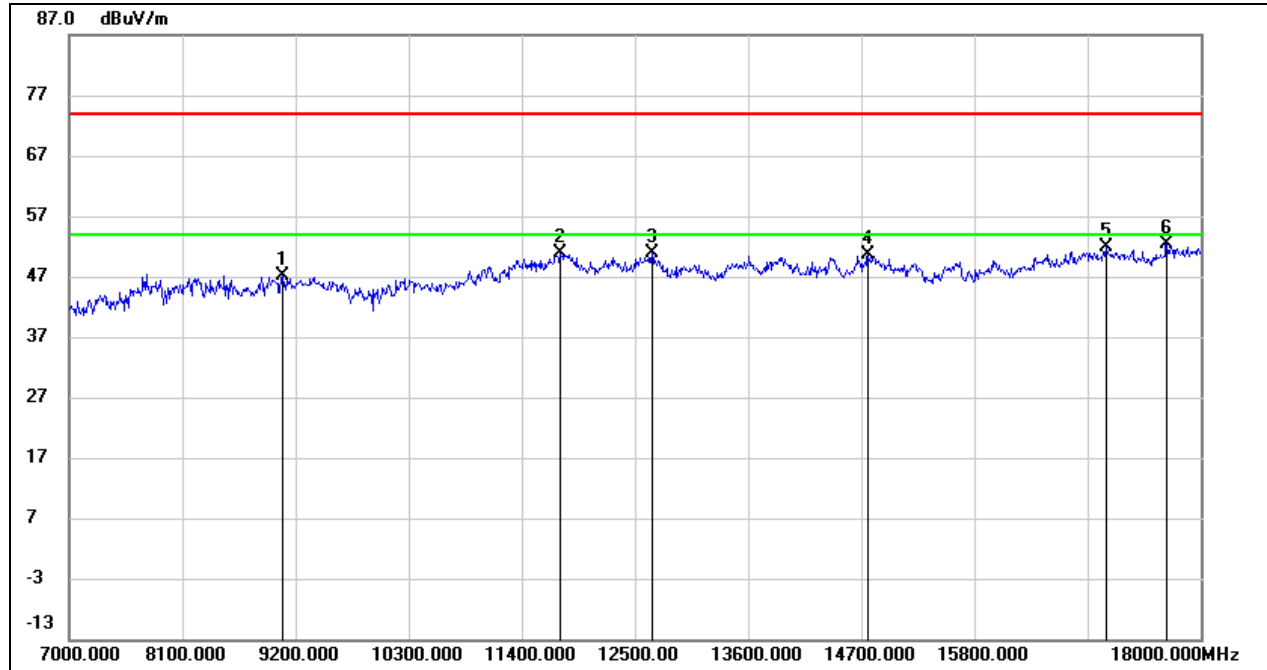

No.	Frequency (MHz)	Reading (dBuV)	Correct (dB/m)	Result (dBuV/m)	Limit (dBuV/m)	Margin (dB)	Remark
1	9079.000	37.10	10.10	47.20	74.00	-26.80	peak
2	11774.000	35.47	15.47	50.94	74.00	-23.06	peak
3	12665.000	35.57	15.41	50.98	74.00	-23.02	peak
4	14766.000	33.78	16.74	50.52	74.00	-23.48	peak
5	17076.000	31.33	20.54	51.87	74.00	-22.13	peak
6	17670.000	30.67	21.70	52.37	74.00	-21.63	peak

Note: 1. Measurement = Reading Level + Correct Factor.
 2. If Peak Result complies with AV limit, AV Result is deemed to comply with AV limit.
 3. Peak: Peak detector.
 4. Filter losses were only considered in the spurious frequency bands and the authorized band was not corrected for High Pass Filter losses.
 5. Proper operation of the transmitter prior to adding the filter to the measurement chain.
 6. Owing to the highest peak level of unwanted emission out of the restricted bands are lower than the line(54dBuV/m) in the graph, so all the peak test point was deemed to comply with the limits -27dBm/MHz (68.2dBuV/m) list in the standard CFR 47 FCC §15.407 (b) and ISED RSS-247 6.2.

HARMONICS AND SPURIOUS EMISSIONS (HIGH CHANNEL, HORIZONTAL)

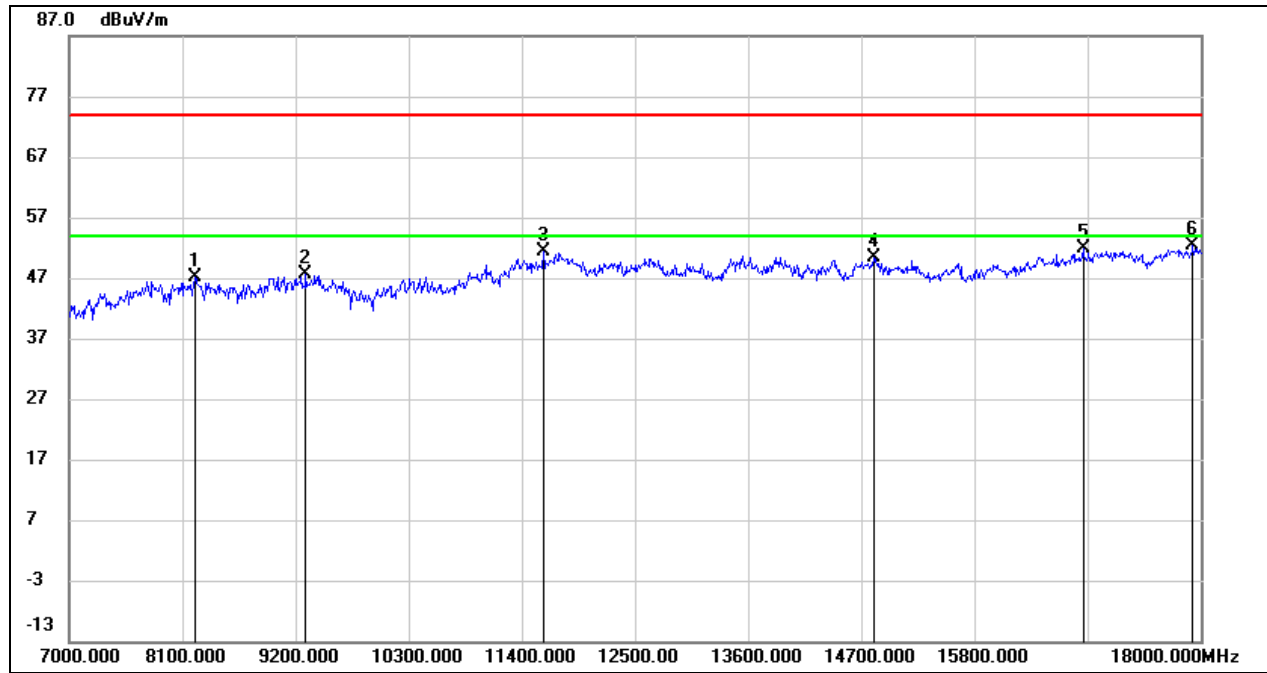

No.	Frequency (MHz)	Reading (dBuV)	Correct (dB/m)	Result (dBuV/m)	Limit (dBuV/m)	Margin (dB)	Remark
1	8221.000	37.80	9.28	47.08	74.00	-26.92	peak
2	9299.000	37.87	9.80	47.67	74.00	-26.33	peak
3	11609.000	36.88	14.56	51.44	74.00	-22.56	peak
4	14821.000	33.45	16.81	50.26	74.00	-23.74	peak
5	16856.000	32.08	19.87	51.95	74.00	-22.05	peak
6	17923.000	29.65	22.69	52.34	74.00	-21.66	peak

Note: 1. Measurement = Reading Level + Correct Factor.
 2. If Peak Result complies with AV limit, AV Result is deemed to comply with AV limit.
 3. Peak: Peak detector.
 4. Filter losses were only considered in the spurious frequency bands and the authorized band was not corrected for High Pass Filter losses.
 5. Proper operation of the transmitter prior to adding the filter to the measurement chain.
 6. Owing to the highest peak level of unwanted emission out of the restricted bands are lower than the line(54dBuV/m) in the graph, so all the peak test point was deemed to comply with the limits -27dBm/MHz (68.2dBuV/m) list in the standard CFR 47 FCC §15.407 (b) and ISED RSS-247 6.2.

HARMONICS AND SPURIOUS EMISSIONS (HIGH CHANNEL, VERTICAL)

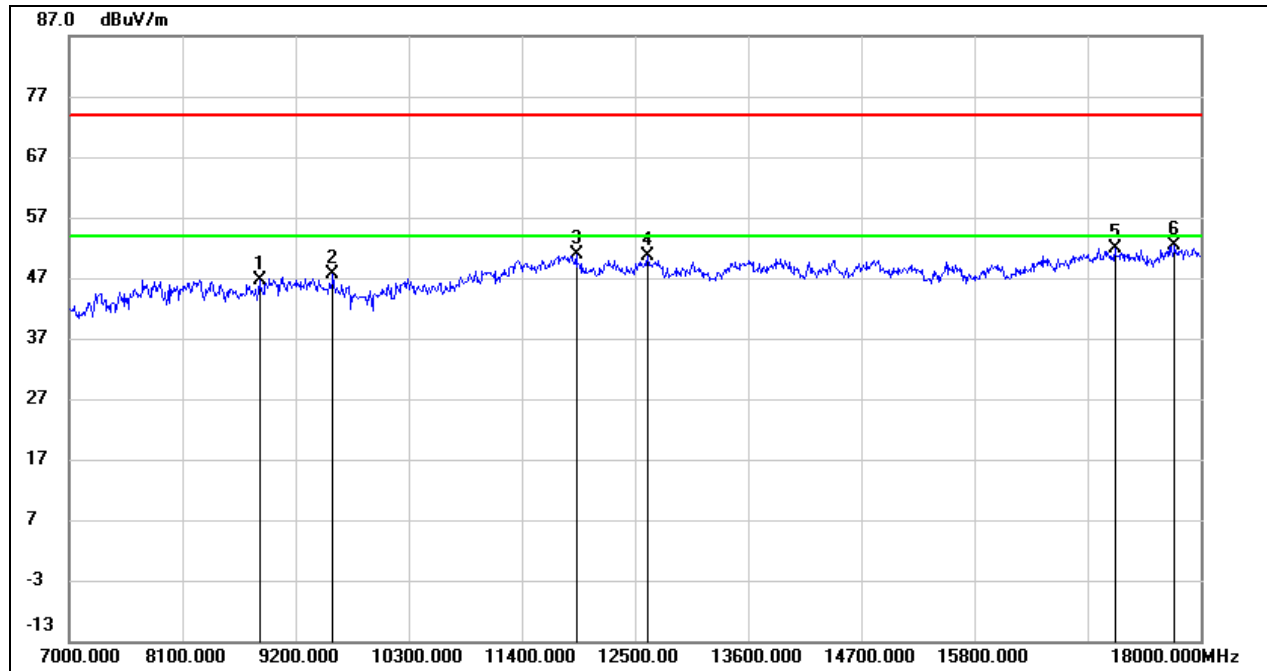

No.	Frequency (MHz)	Reading (dBuV)	Correct (dB/m)	Result (dBuV/m)	Limit (dBuV/m)	Margin (dB)	Remark
1	8848.000	37.70	9.03	46.73	74.00	-27.27	peak
2	9563.000	37.06	10.45	47.51	74.00	-26.49	peak
3	11928.000	35.48	15.42	50.90	74.00	-23.10	peak
4	12621.000	35.19	15.33	50.52	74.00	-23.48	peak
5	17164.000	30.97	20.89	51.86	74.00	-22.14	peak
6	17747.000	29.98	22.31	52.29	74.00	-21.71	peak

Note: 1. Measurement = Reading Level + Correct Factor.
 2. If Peak Result complies with AV limit, AV Result is deemed to comply with AV limit.
 3. Peak: Peak detector.
 4. Filter losses were only considered in the spurious frequency bands and the authorized band was not corrected for High Pass Filter losses.
 5. Proper operation of the transmitter prior to adding the filter to the measurement chain.
 6. Owing to the highest peak level of unwanted emission out of the restricted bands are lower than the line(54dBuV/m) in the graph, so all the peak test point was deemed to comply with the limits -27dBm/MHz (68.2dBuV/m) list in the standard CFR 47 FCC §15.407 (b) and ISED RSS-247 6.2.

UNII-2C BAND

HARMONICS AND SPURIOUS EMISSIONS (LOW CHANNEL, HORIZONTAL)

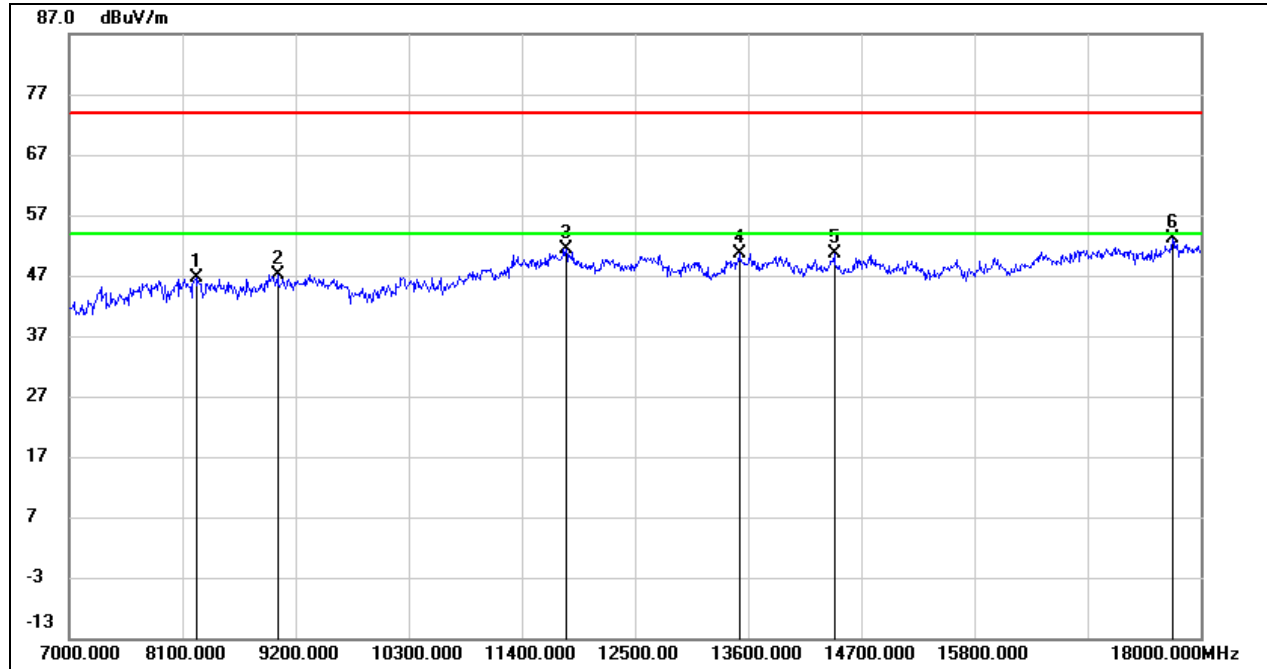

No.	Frequency (MHz)	Reading (dBuV)	Correct (dB/m)	Result (dBuV/m)	Limit (dBuV/m)	Margin (dB)	Remark
1	8232.000	37.50	9.23	46.73	74.00	-27.27	peak
2	9024.000	36.77	10.47	47.24	74.00	-26.76	peak
3	11829.000	35.76	15.57	51.33	74.00	-22.67	peak
4	13512.000	34.22	16.41	50.63	74.00	-23.37	peak
5	14436.000	33.94	16.79	50.73	74.00	-23.27	peak
6	17725.000	30.90	22.13	53.03	74.00	-20.97	peak

Note: 1. Measurement = Reading Level + Correct Factor.
 2. If Peak Result complies with AV limit, AV Result is deemed to comply with AV limit.
 3. Peak: Peak detector.
 4. Filter losses were only considered in the spurious frequency bands and the authorized band was not corrected for High Pass Filter losses.
 5. Proper operation of the transmitter prior to adding the filter to the measurement chain.
 6. Owing to the highest peak level of unwanted emission out of the restricted bands are lower than the line(54dBuV/m) in the graph, so all the peak test point was deemed to comply with the limits -27dBm/MHz (68.2dBuV/m) list in the standard CFR 47 FCC §15.407 (b) and ISED RSS-247 6.2.



HARMONICS AND SPURIOUS EMISSIONS (LOW CHANNEL, VERTICAL)

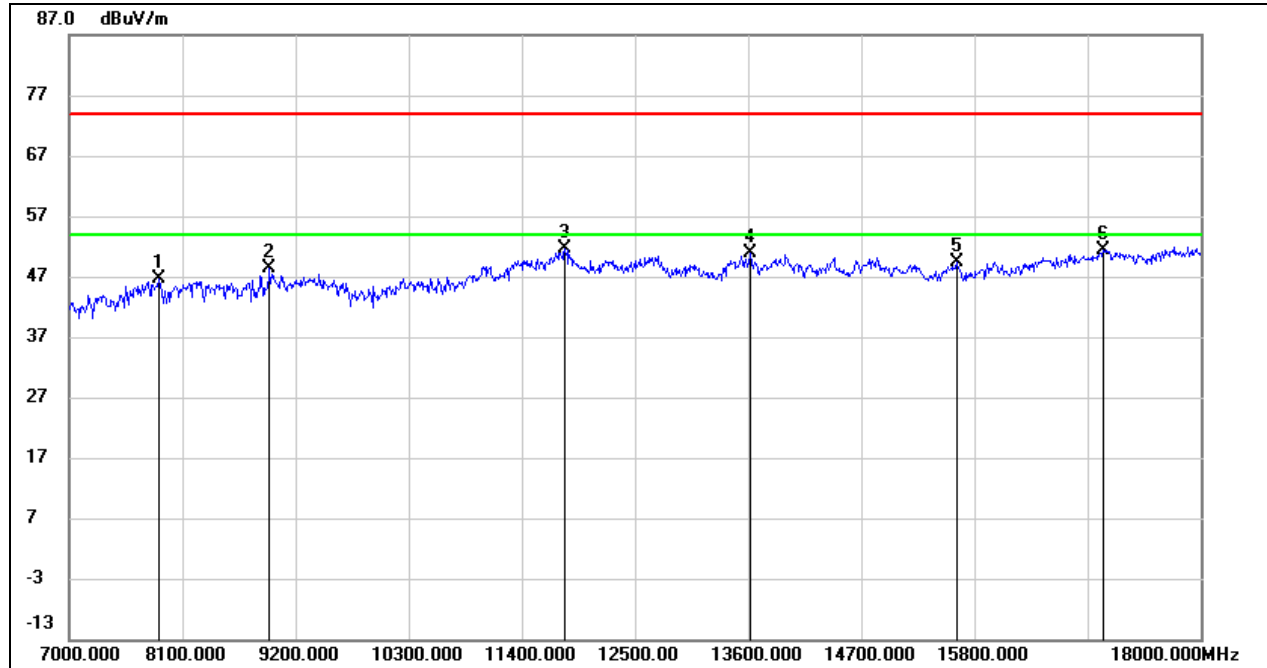

No.	Frequency (MHz)	Reading (dBuV)	Correct (dB/m)	Result (dBuV/m)	Limit (dBuV/m)	Margin (dB)	Remark
1	7869.000	38.52	8.05	46.57	74.00	-27.43	peak
2	8947.000	38.21	10.07	48.28	74.00	-25.72	peak
3	11818.000	36.06	15.58	51.64	74.00	-22.36	peak
4	13622.000	34.43	16.48	50.91	74.00	-23.09	peak
5	15624.000	32.67	16.71	49.38	74.00	-24.62	peak
6	17054.000	30.97	20.45	51.42	74.00	-22.58	peak

Note: 1. Measurement = Reading Level + Correct Factor.
 2. If Peak Result complies with AV limit, AV Result is deemed to comply with AV limit.
 3. Peak: Peak detector.
 4. Filter losses were only considered in the spurious frequency bands and the authorized band was not corrected for High Pass Filter losses.
 5. Proper operation of the transmitter prior to adding the filter to the measurement chain.
 6. Owing to the highest peak level of unwanted emission out of the restricted bands are lower than the line(54dBuV/m) in the graph, so all the peak test point was deemed to comply with the limits -27dBm/MHz (68.2dBuV/m) list in the standard CFR 47 FCC §15.407 (b) and ISED RSS-247 6.2.



HARMONICS AND SPURIOUS EMISSIONS (MID CHANNEL, HORIZONTAL)

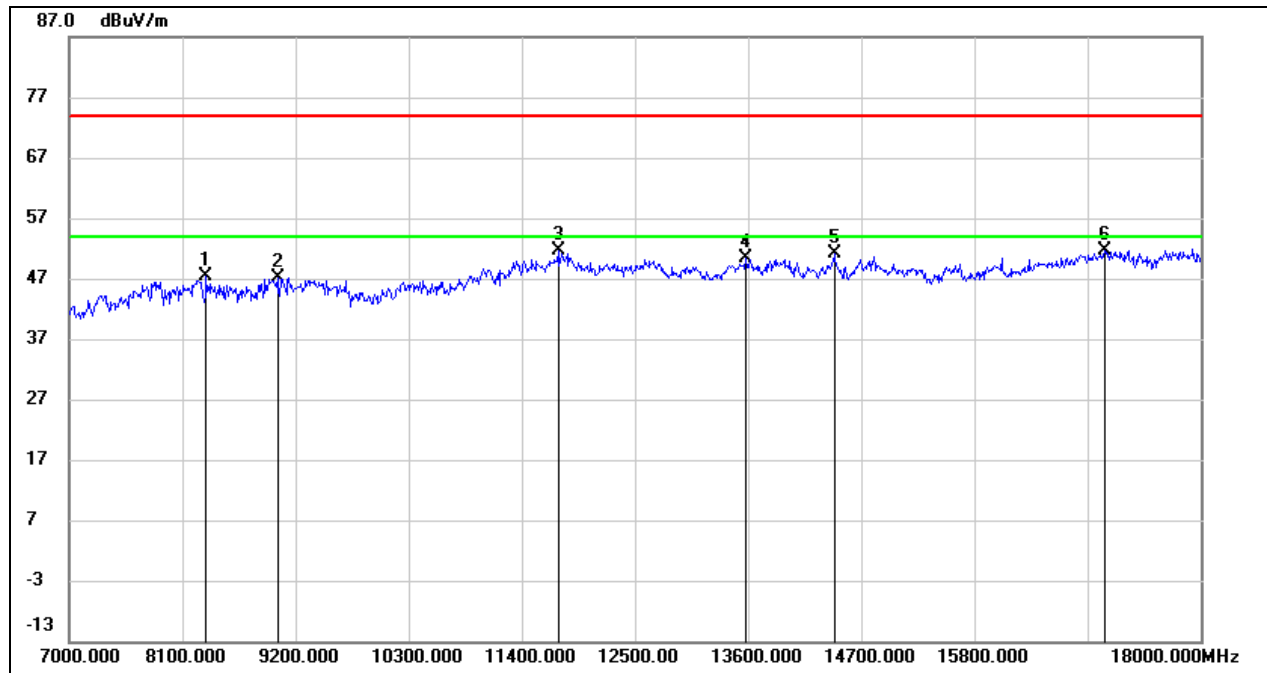

No.	Frequency (MHz)	Reading (dBuV)	Correct (dB/m)	Result (dBuV/m)	Limit (dBuV/m)	Margin (dB)	Remark
1	8331.000	38.53	8.85	47.38	74.00	-26.62	peak
2	9024.000	36.68	10.47	47.15	74.00	-26.85	peak
3	11752.000	36.38	15.35	51.73	74.00	-22.27	peak
4	13578.000	33.97	16.43	50.40	74.00	-23.60	peak
5	14436.000	34.43	16.79	51.22	74.00	-22.78	peak
6	17065.000	31.21	20.49	51.70	74.00	-22.30	peak

Note: 1. Measurement = Reading Level + Correct Factor.
 2. If Peak Result complies with AV limit, AV Result is deemed to comply with AV limit.
 3. Peak: Peak detector.
 4. Filter losses were only considered in the spurious frequency bands and the authorized band was not corrected for High Pass Filter losses.
 5. Proper operation of the transmitter prior to adding the filter to the measurement chain.
 6. Owing to the highest peak level of unwanted emission out of the restricted bands are lower than the line(54dBuV/m) in the graph, so all the peak test point was deemed to comply with the limits -27dBm/MHz (68.2dBuV/m) list in the standard CFR 47 FCC §15.407 (b) and ISED RSS-247 6.2.



HARMONICS AND SPURIOUS EMISSIONS (MID CHANNEL, VERTICAL)

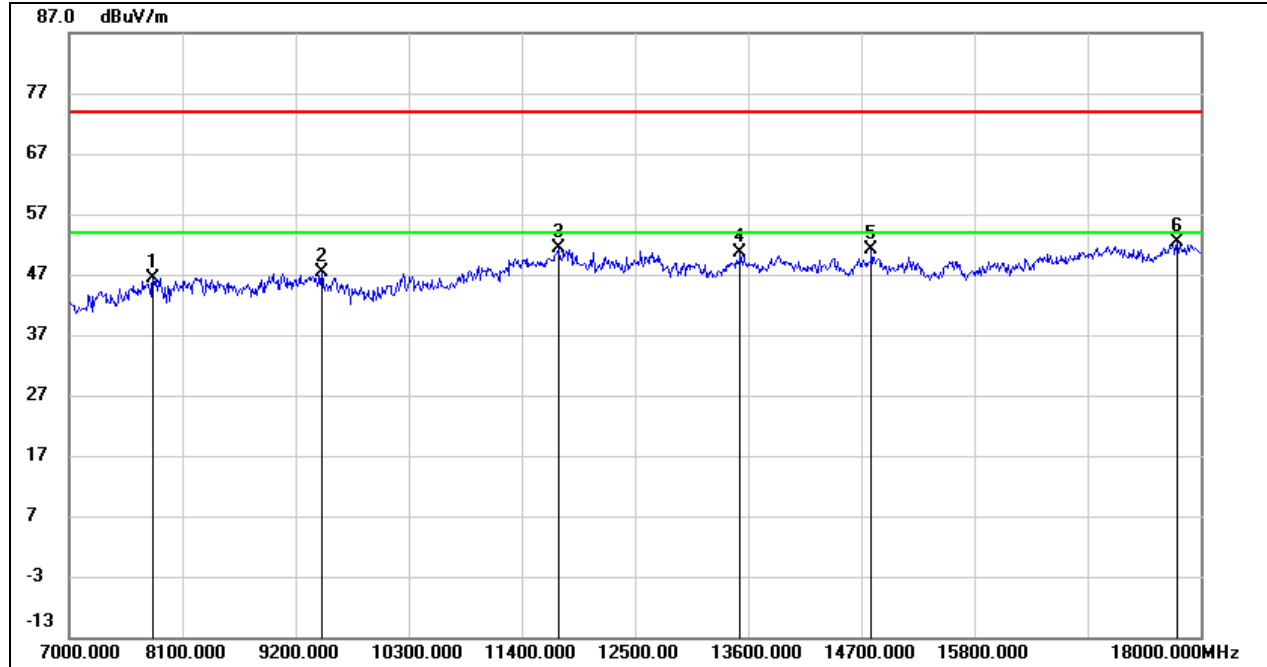

No.	Frequency (MHz)	Reading (dBuV)	Correct (dB/m)	Result (dBuV/m)	Limit (dBuV/m)	Margin (dB)	Remark
1	7814.000	38.21	8.21	46.42	74.00	-27.58	peak
2	9453.000	37.08	10.39	47.47	74.00	-26.53	peak
3	11752.000	36.06	15.35	51.41	74.00	-22.59	peak
4	13523.000	34.27	16.42	50.69	74.00	-23.31	peak
5	14799.000	34.41	16.80	51.21	74.00	-22.79	peak
6	17769.000	29.86	22.48	52.34	74.00	-21.66	peak

Note: 1. Measurement = Reading Level + Correct Factor.
 2. If Peak Result complies with AV limit, AV Result is deemed to comply with AV limit.
 3. Peak: Peak detector.
 4. Filter losses were only considered in the spurious frequency bands and the authorized band was not corrected for High Pass Filter losses.
 5. Proper operation of the transmitter prior to adding the filter to the measurement chain.
 6. Owing to the highest peak level of unwanted emission out of the restricted bands are lower than the line(54dBuV/m) in the graph, so all the peak test point was deemed to comply with the limits -27dBm/MHz (68.2dBuV/m) list in the standard CFR 47 FCC §15.407 (b) and ISED RSS-247 6.2.



HARMONICS AND SPURIOUS EMISSIONS (HIGH CHANNEL, HORIZONTAL)

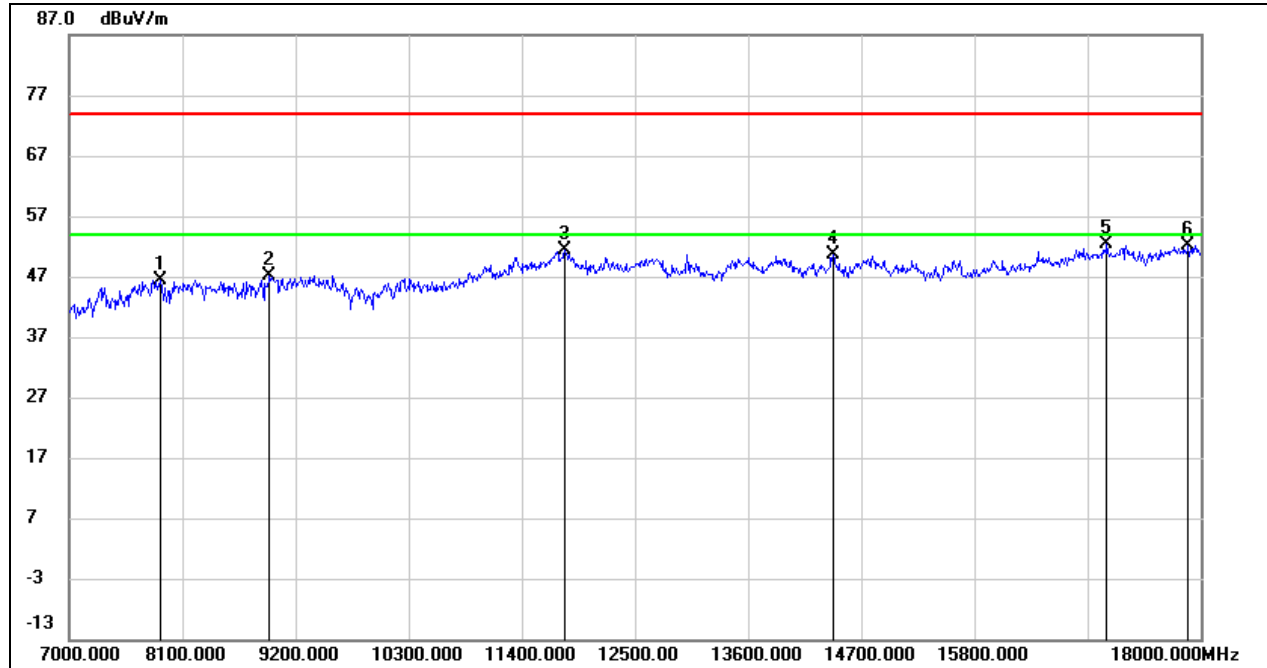

No.	Frequency (MHz)	Reading (dBuV)	Correct (dB/m)	Result (dBuV/m)	Limit (dBuV/m)	Margin (dB)	Remark
1	7880.000	38.38	8.01	46.39	74.00	-27.61	peak
2	8947.000	37.11	10.07	47.18	74.00	-26.82	peak
3	11818.000	35.88	15.58	51.46	74.00	-22.54	peak
4	14425.000	33.85	16.80	50.65	74.00	-23.35	peak
5	17087.000	31.69	20.58	52.27	74.00	-21.73	peak
6	17879.000	29.53	22.70	52.23	74.00	-21.77	peak

Note: 1. Measurement = Reading Level + Correct Factor.
 2. If Peak Result complies with AV limit, AV Result is deemed to comply with AV limit.
 3. Peak: Peak detector.
 4. Filter losses were only considered in the spurious frequency bands and the authorized band was not corrected for High Pass Filter losses.
 5. Proper operation of the transmitter prior to adding the filter to the measurement chain.
 6. Owing to the highest peak level of unwanted emission out of the restricted bands are lower than the line(54dBuV/m) in the graph, so all the peak test point was deemed to comply with the limits -27dBm/MHz (68.2dBuV/m) list in the standard CFR 47 FCC §15.407 (b) and ISED RSS-247 6.2.

HARMONICS AND SPURIOUS EMISSIONS (HIGH CHANNEL, VERTICAL)

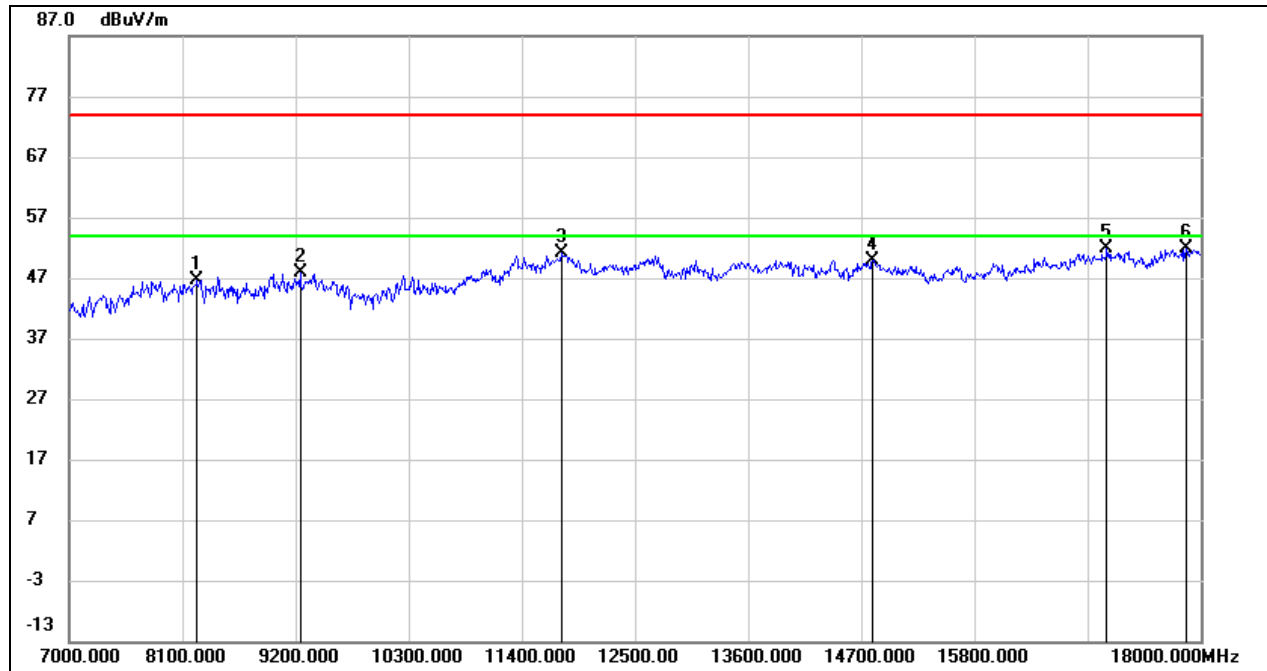

No.	Frequency (MHz)	Reading (dBuV)	Correct (dB/m)	Result (dBuV/m)	Limit (dBuV/m)	Margin (dB)	Remark
1	8243.000	37.48	9.19	46.67	74.00	-27.33	peak
2	9244.000	38.28	9.51	47.79	74.00	-26.21	peak
3	11785.000	35.54	15.52	51.06	74.00	-22.94	peak
4	14810.000	33.14	16.80	49.94	74.00	-24.06	peak
5	17087.000	31.23	20.58	51.81	74.00	-22.19	peak
6	17857.000	29.09	22.70	51.79	74.00	-22.21	peak

Note: 1. Measurement = Reading Level + Correct Factor.
 2. If Peak Result complies with AV limit, AV Result is deemed to comply with AV limit.
 3. Peak: Peak detector.
 4. Filter losses were only considered in the spurious frequency bands and the authorized band was not corrected for High Pass Filter losses.
 5. Proper operation of the transmitter prior to adding the filter to the measurement chain.
 6. Owing to the highest peak level of unwanted emission out of the restricted bands are lower than the line(54dBuV/m) in the graph, so all the peak test point was deemed to comply with the limits -27dBm/MHz (68.2dBuV/m) list in the standard CFR 47 FCC §15.407 (b) and ISED RSS-247 6.2.



STRADDLE CHANNEL 142

HARMONICS AND SPURIOUS EMISSIONS (HORIZONTAL)

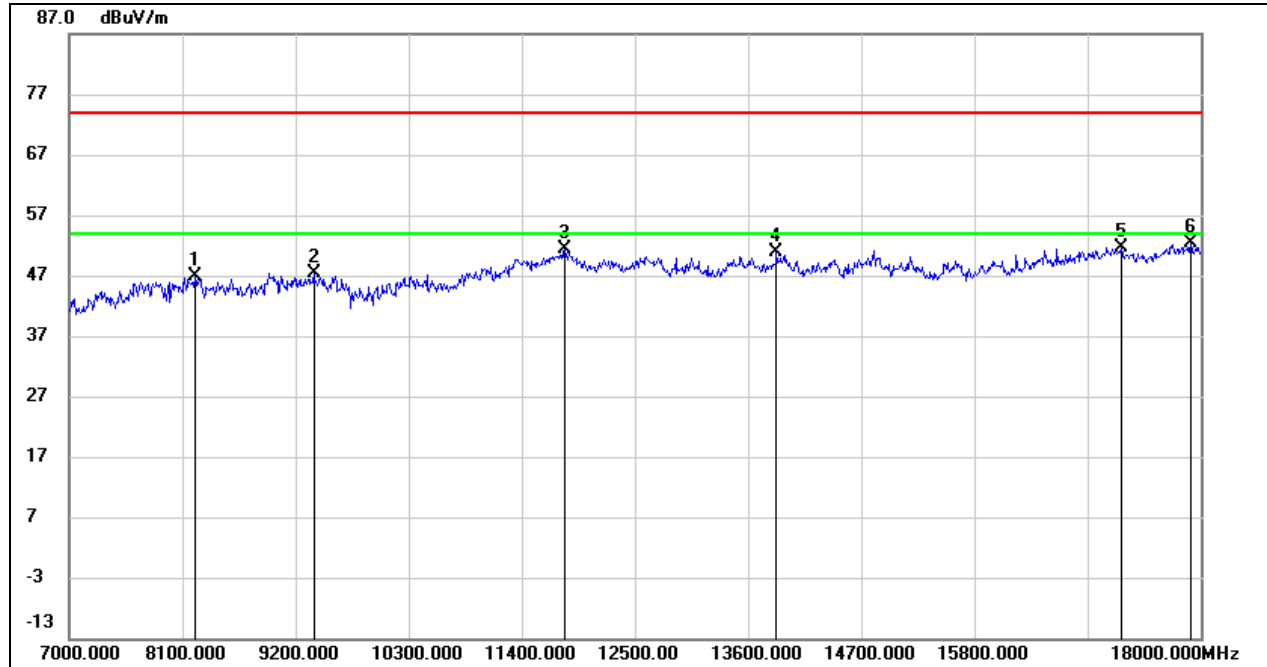

No.	Frequency (MHz)	Reading (dBuV)	Correct (dB/m)	Result (dBuV/m)	Limit (dBuV/m)	Margin (dB)	Remark
1	8221.000	37.53	9.28	46.81	74.00	-27.19	peak
2	9376.000	37.21	10.19	47.40	74.00	-26.60	peak
3	11818.000	35.79	15.58	51.37	74.00	-22.63	peak
4	13875.000	33.84	16.92	50.76	74.00	-23.24	peak
5	17230.000	30.58	20.99	51.57	74.00	-22.43	peak
6	17901.000	29.58	22.69	52.27	74.00	-21.73	peak

Note: 1. Measurement = Reading Level + Correct Factor.
 2. If Peak Result complies with AV limit, AV Result is deemed to comply with AV limit.
 3. Peak: Peak detector.
 4. Filter losses were only considered in the spurious frequency bands and the authorized band was not corrected for High Pass Filter losses.
 5. Proper operation of the transmitter prior to adding the filter to the measurement chain.
 6. Owing to the highest peak level of unwanted emission out of the restricted bands are lower than the line(54dBuV/m) in the graph, so all the peak test point was deemed to comply with the limits -27dBm/MHz (68.2dBuV/m) list in the standard CFR 47 FCC §15.407 (b) and ISED RSS-247 6.2.

HARMONICS AND SPURIOUS EMISSIONS (VERTICAL)

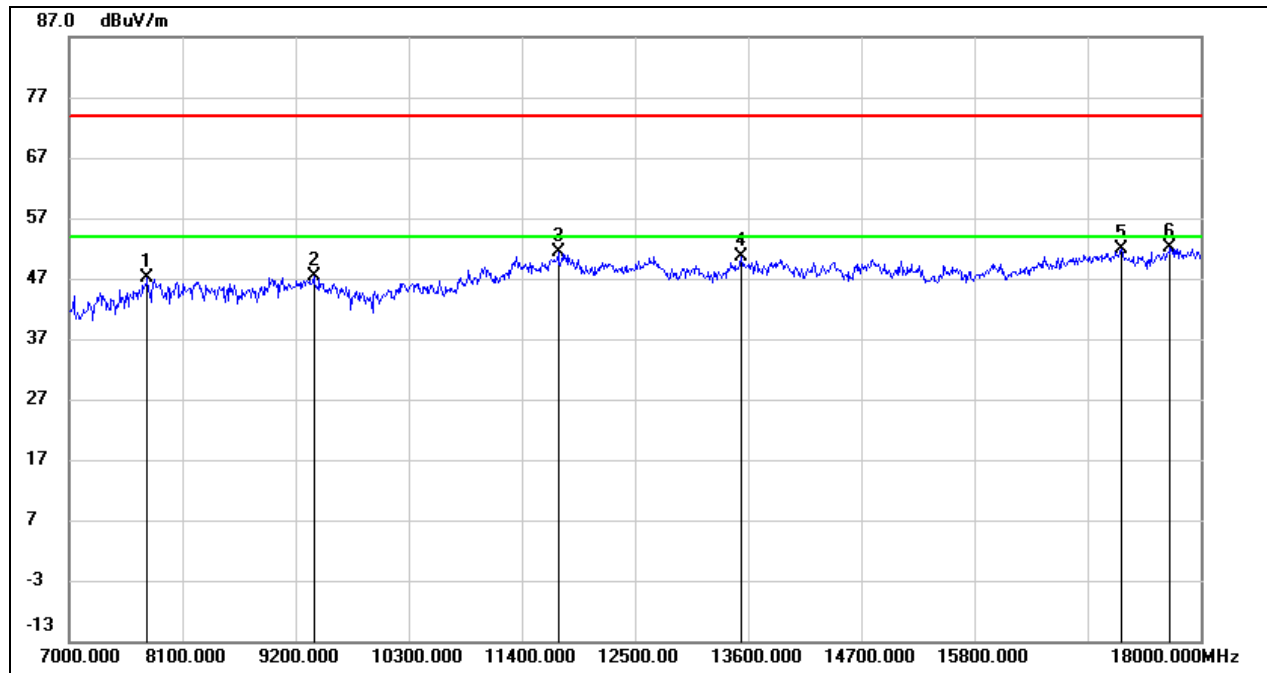

No.	Frequency (MHz)	Reading (dBuV)	Correct (dB/m)	Result (dBuV/m)	Limit (dBuV/m)	Margin (dB)	Remark
1	7759.000	38.92	8.09	47.01	74.00	-26.99	peak
2	9376.000	37.18	10.19	47.37	74.00	-26.63	peak
3	11752.000	36.13	15.35	51.48	74.00	-22.52	peak
4	13534.000	34.21	16.42	50.63	74.00	-23.37	peak
5	17230.000	30.80	20.99	51.79	74.00	-22.21	peak
6	17703.000	30.25	21.96	52.21	74.00	-21.79	peak

Note: 1. Measurement = Reading Level + Correct Factor.
 2. If Peak Result complies with AV limit, AV Result is deemed to comply with AV limit.
 3. Peak: Peak detector.
 4. Filter losses were only considered in the spurious frequency bands and the authorized band was not corrected for High Pass Filter losses.
 5. Proper operation of the transmitter prior to adding the filter to the measurement chain.
 6. Owing to the highest peak level of unwanted emission out of the restricted bands are lower than the line(54dBuV/m) in the graph, so all the peak test point was deemed to comply with the limits -27dBm/MHz (68.2dBuV/m) list in the standard CFR 47 FCC §15.407 (b) and ISSED RSS-247 6.2.



UNII-3 BAND

HARMONICS AND SPURIOUS EMISSIONS (LOW CHANNEL, HORIZONTAL)

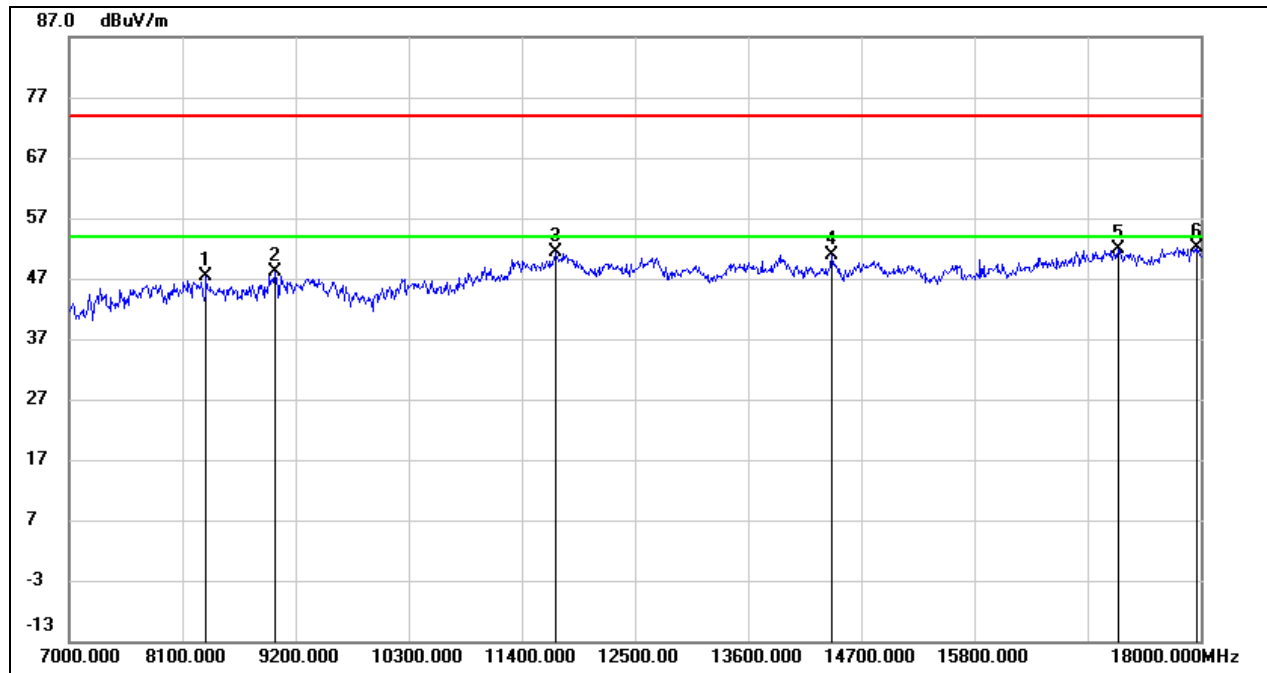

No.	Frequency (MHz)	Reading (dBuV)	Correct (dB/m)	Result (dBuV/m)	Limit (dBuV/m)	Margin (dB)	Remark
1	8331.000	38.45	8.85	47.30	74.00	-26.70	peak
2	9002.000	37.48	10.61	48.09	74.00	-25.91	peak
3	11730.000	36.03	15.23	51.26	74.00	-22.74	peak
4	14414.000	33.99	16.82	50.81	74.00	-23.19	peak
5	17197.000	30.76	21.03	51.79	74.00	-22.21	peak
6	17967.000	29.36	22.67	52.03	74.00	-21.97	peak

Note: 1. Measurement = Reading Level + Correct Factor.
 2. If Peak Result complies with AV limit, AV Result is deemed to comply with AV limit.
 3. Peak: Peak detector.
 4. Filter losses were only considered in the spurious frequency bands and the authorized band was not corrected for High Pass Filter losses.
 5. Proper operation of the transmitter prior to adding the filter to the measurement chain.
 6. Owing to the highest peak level of unwanted emission out of the restricted bands are lower than the line(54dBuV/m) in the graph, so all the peak test point was deemed to comply with the limits -27dBm/MHz (68.2dBuV/m) list in the standard CFR 47 FCC §15.407 (b) and ISED RSS-247 6.2.



HARMONICS AND SPURIOUS EMISSIONS (LOW CHANNEL, VERTICAL)

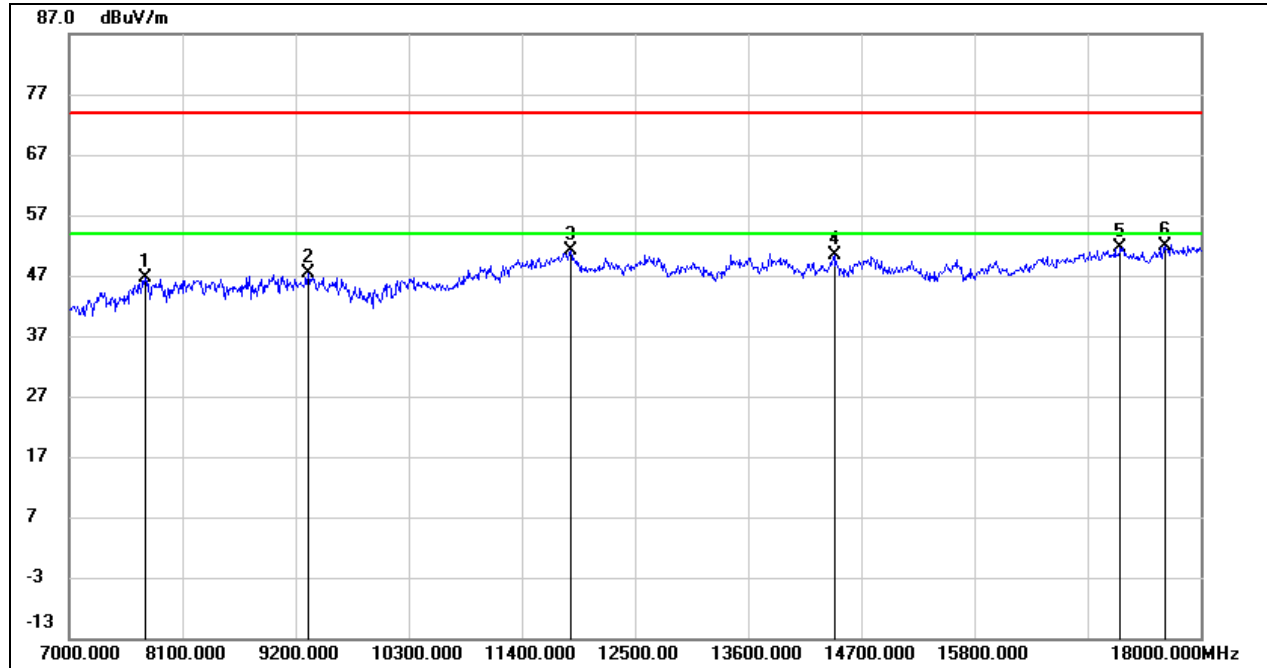

No.	Frequency (MHz)	Reading (dBuV)	Correct (dB/m)	Result (dBuV/m)	Limit (dBuV/m)	Margin (dB)	Remark
1	7737.000	38.51	8.00	46.51	74.00	-27.49	peak
2	9321.000	37.37	9.91	47.28	74.00	-26.72	peak
3	11873.000	35.60	15.50	51.10	74.00	-22.90	peak
4	14436.000	33.51	16.79	50.30	74.00	-23.70	peak
5	17219.000	30.62	21.01	51.63	74.00	-22.37	peak
6	17648.000	30.27	21.54	51.81	74.00	-22.19	peak

Note: 1. Measurement = Reading Level + Correct Factor.
 2. If Peak Result complies with AV limit, AV Result is deemed to comply with AV limit.
 3. Peak: Peak detector.
 4. Filter losses were only considered in the spurious frequency bands and the authorized band was not corrected for High Pass Filter losses.
 5. Proper operation of the transmitter prior to adding the filter to the measurement chain.
 6. Owing to the highest peak level of unwanted emission out of the restricted bands are lower than the line(54dBuV/m) in the graph, so all the peak test point was deemed to comply with the limits -27dBm/MHz (68.2dBuV/m) list in the standard CFR 47 FCC §15.407 (b) and ISED RSS-247 6.2.



HARMONICS AND SPURIOUS EMISSIONS (HIGH CHANNEL, HORIZONTAL)

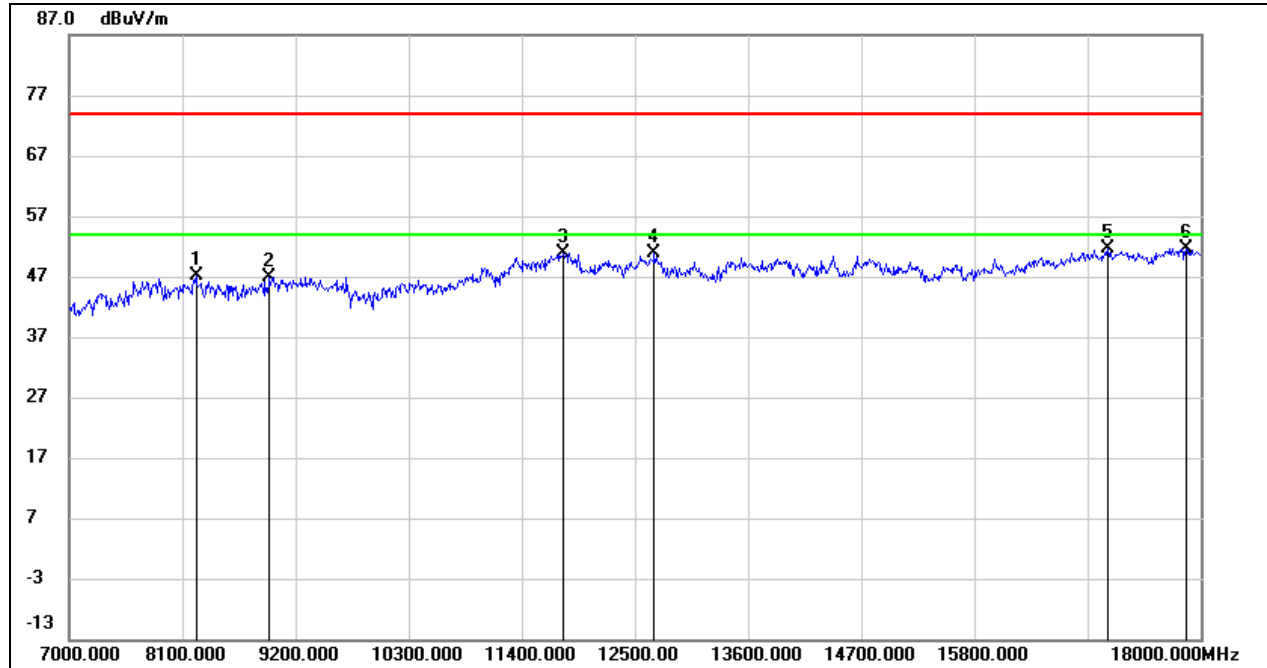

No.	Frequency (MHz)	Reading (dBuV)	Correct (dB/m)	Result (dBuV/m)	Limit (dBuV/m)	Margin (dB)	Remark
1	8232.000	37.86	9.23	47.09	74.00	-26.91	peak
2	8947.000	36.76	10.07	46.83	74.00	-27.17	peak
3	11807.000	35.34	15.61	50.95	74.00	-23.05	peak
4	12687.000	35.44	15.45	50.89	74.00	-23.11	peak
5	17098.000	30.88	20.63	51.51	74.00	-22.49	peak
6	17857.000	29.01	22.70	51.71	74.00	-22.29	peak

Note: 1. Measurement = Reading Level + Correct Factor.
 2. If Peak Result complies with AV limit, AV Result is deemed to comply with AV limit.
 3. Peak: Peak detector.
 4. Filter losses were only considered in the spurious frequency bands and the authorized band was not corrected for High Pass Filter losses.
 5. Proper operation of the transmitter prior to adding the filter to the measurement chain.
 6. Owing to the highest peak level of unwanted emission out of the restricted bands are lower than the line(54dBuV/m) in the graph, so all the peak test point was deemed to comply with the limits -27dBm/MHz (68.2dBuV/m) list in the standard CFR 47 FCC §15.407 (b) and ISED RSS-247 6.2.



HARMONICS AND SPURIOUS EMISSIONS (HIGH CHANNEL, VERTICAL)

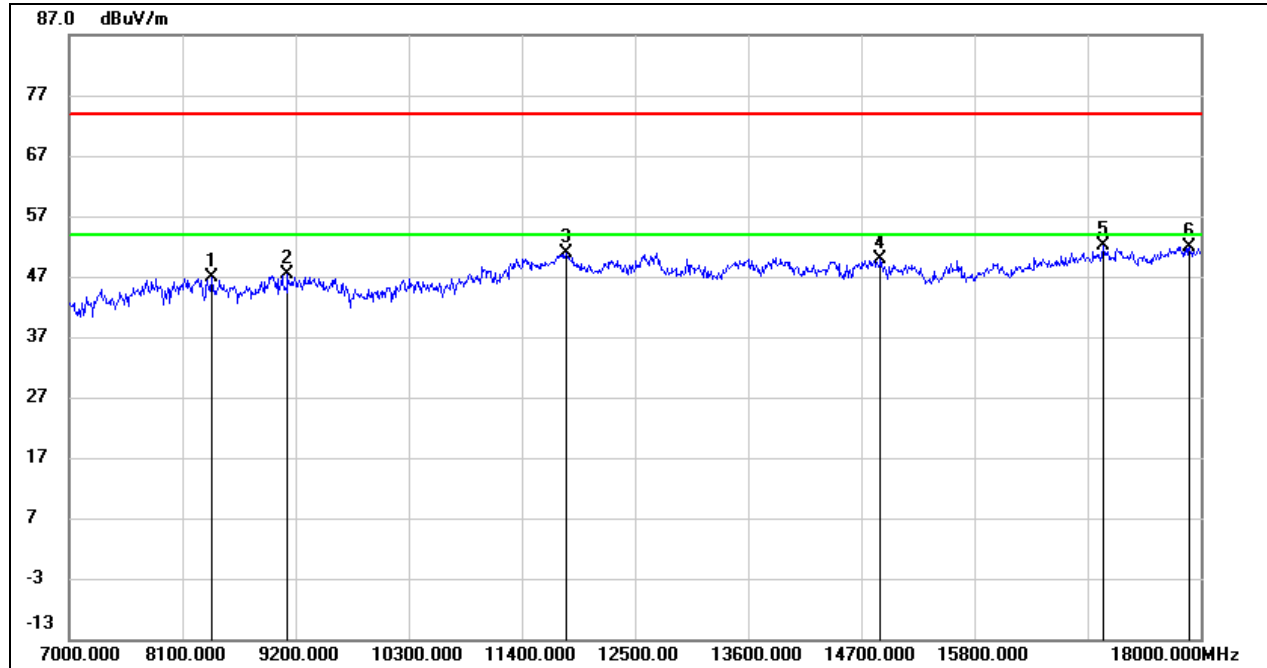

No.	Frequency (MHz)	Reading (dBuV)	Correct (dB/m)	Result (dBuV/m)	Limit (dBuV/m)	Margin (dB)	Remark
1	8386.000	38.12	8.64	46.76	74.00	-27.24	peak
2	9123.000	37.54	9.81	47.35	74.00	-26.65	peak
3	11829.000	35.29	15.57	50.86	74.00	-23.14	peak
4	14887.000	33.06	16.84	49.90	74.00	-24.10	peak
5	17054.000	31.79	20.45	52.24	74.00	-21.76	peak
6	17890.000	29.25	22.70	51.95	74.00	-22.05	peak

Note: 1. Measurement = Reading Level + Correct Factor.
 2. If Peak Result complies with AV limit, AV Result is deemed to comply with AV limit.
 3. Peak: Peak detector.
 4. Filter losses were only considered in the spurious frequency bands and the authorized band was not corrected for High Pass Filter losses.
 5. Proper operation of the transmitter prior to adding the filter to the measurement chain.
 6. Owing to the highest peak level of unwanted emission out of the restricted bands are lower than the line(54dBuV/m) in the graph, so all the peak test point was deemed to comply with the limits -27dBm/MHz (68.2dBuV/m) list in the standard CFR 47 FCC §15.407 (b) and ISED RSS-247 6.2.

8.3.4. 802.11ac VHT80 MIMO MODE

UNII-1 BAND

HARMONICS AND SPURIOUS EMISSIONS (LOW CHANNEL, HORIZONTAL)

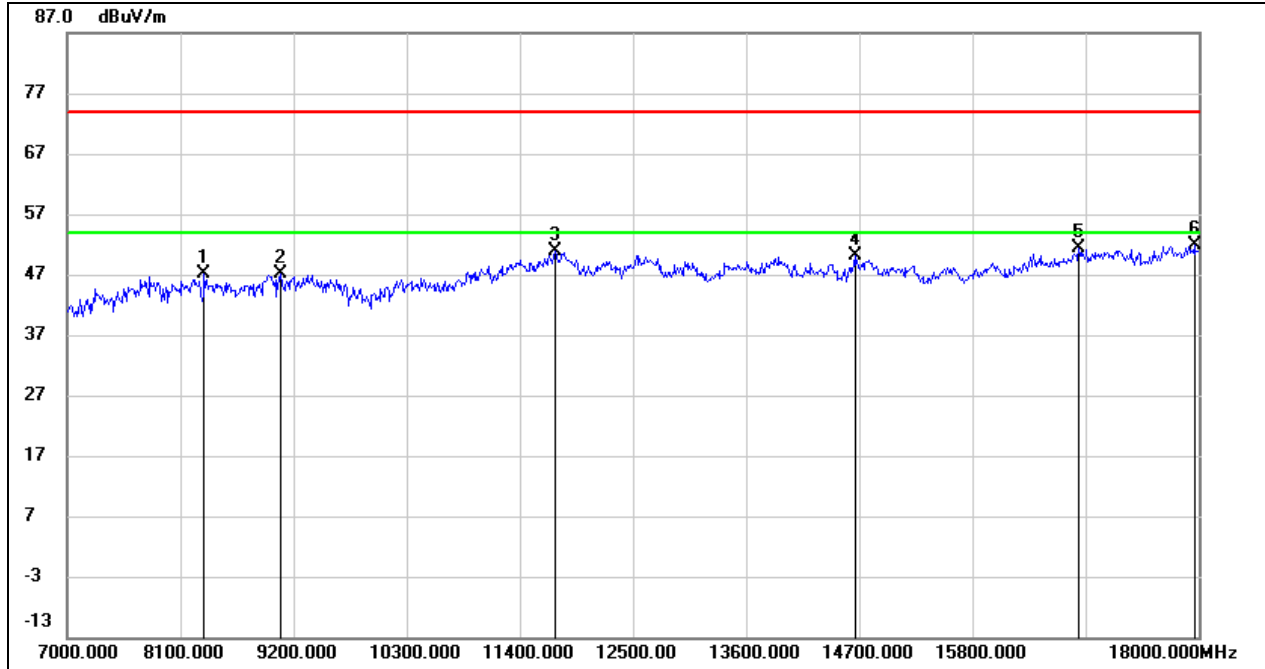

No.	Frequency (MHz)	Reading (dBuV)	Correct (dB/m)	Result (dBuV/m)	Limit (dBuV/m)	Margin (dB)	Remark
1	8331.000	38.16	8.85	47.01	74.00	-26.99	peak
2	9079.000	36.96	10.10	47.06	74.00	-26.94	peak
3	11741.000	35.60	15.28	50.88	74.00	-23.12	peak
4	14656.000	33.48	16.56	50.04	74.00	-23.96	peak
5	16834.000	31.51	19.82	51.33	74.00	-22.67	peak
6	17956.000	29.30	22.68	51.98	74.00	-22.02	peak

Note: 1. Measurement = Reading Level + Correct Factor.
 2. If Peak Result complies with AV limit, AV Result is deemed to comply with AV limit.
 3. Peak: Peak detector.
 4. Filter losses were only considered in the spurious frequency bands and the authorized band was not corrected for High Pass Filter losses.
 5. Proper operation of the transmitter prior to adding the filter to the measurement chain.
 6. Owing to the highest peak level of unwanted emission out of the restricted bands are lower than the line(54dBuV/m) in the graph, so all the peak test point was deemed to comply with the limits -27dBm/MHz (68.2dBuV/m) list in the standard CFR 47 FCC §15.407 (b) and ISSED RSS-247 6.2.



HARMONICS AND SPURIOUS EMISSIONS (LOW CHANNEL, VERTICAL)

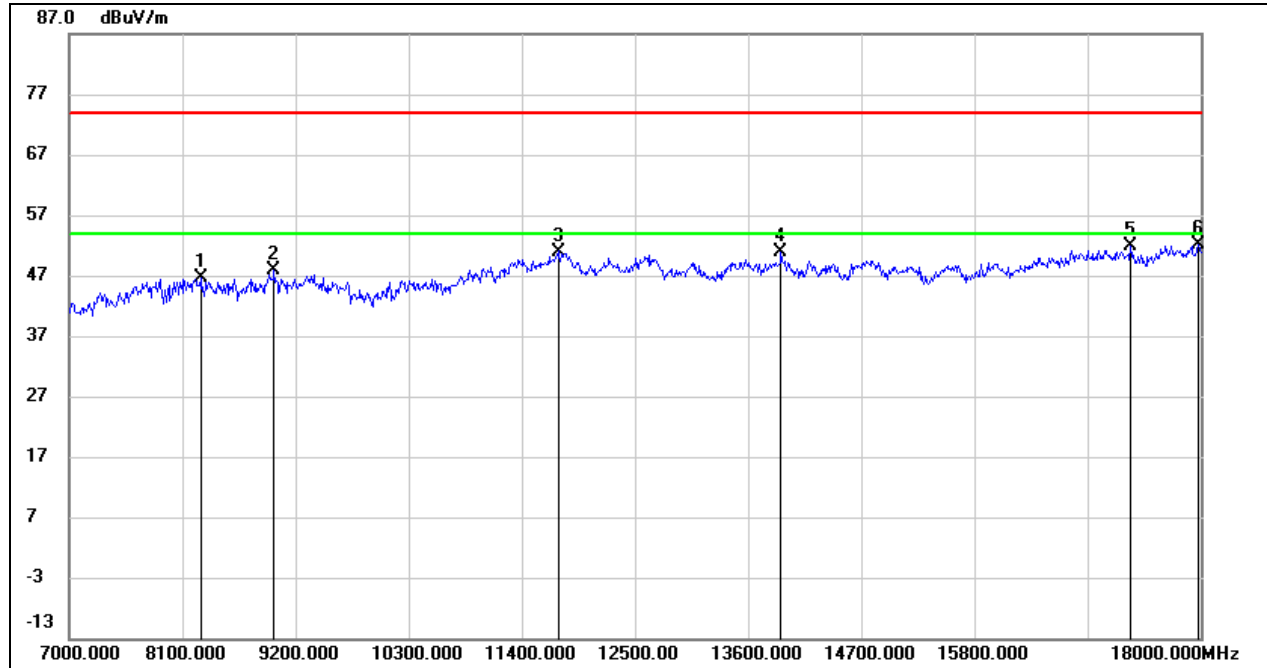

No.	Frequency (MHz)	Reading (dBuV)	Correct (dB/m)	Result (dBuV/m)	Limit (dBuV/m)	Margin (dB)	Remark
1	8276.000	37.54	9.06	46.60	74.00	-27.40	peak
2	8991.000	37.28	10.53	47.81	74.00	-26.19	peak
3	11752.000	35.65	15.35	51.00	74.00	-23.00	peak
4	13919.000	34.01	16.89	50.90	74.00	-23.10	peak
5	17318.000	30.94	20.86	51.80	74.00	-22.20	peak
6	17978.000	29.34	22.68	52.02	74.00	-21.98	peak

Note: 1. Measurement = Reading Level + Correct Factor.
 2. If Peak Result complies with AV limit, AV Result is deemed to comply with AV limit.
 3. Peak: Peak detector.
 4. Filter losses were only considered in the spurious frequency bands and the authorized band was not corrected for High Pass Filter losses.
 5. Proper operation of the transmitter prior to adding the filter to the measurement chain.
 6. Owing to the highest peak level of unwanted emission out of the restricted bands are lower than the line(54dBuV/m) in the graph, so all the peak test point was deemed to comply with the limits -27dBm/MHz (68.2dBuV/m) list in the standard CFR 47 FCC §15.407 (b) and ISED RSS-247 6.2.



UNII-2A BAND

HARMONICS AND SPURIOUS EMISSIONS (LOW CHANNEL, HORIZONTAL)

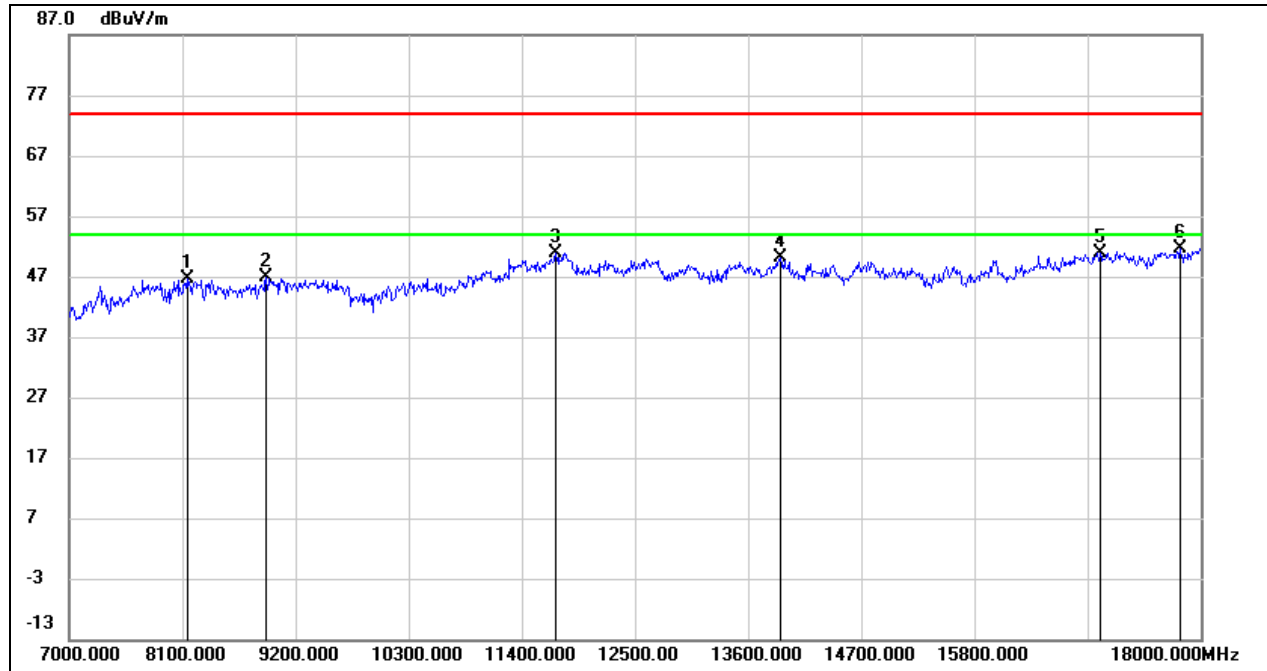

No.	Frequency (MHz)	Reading (dBuV)	Correct (dB/m)	Result (dBuV/m)	Limit (dBuV/m)	Margin (dB)	Remark
1	8144.000	37.73	8.88	46.61	74.00	-27.39	peak
2	8914.000	37.05	9.72	46.77	74.00	-27.23	peak
3	11730.000	35.63	15.23	50.86	74.00	-23.14	peak
4	13919.000	33.28	16.89	50.17	74.00	-23.83	peak
5	17021.000	30.65	20.32	50.97	74.00	-23.03	peak
6	17802.000	28.86	22.72	51.58	74.00	-22.42	peak

Note: 1. Measurement = Reading Level + Correct Factor.
 2. If Peak Result complies with AV limit, AV Result is deemed to comply with AV limit.
 3. Peak: Peak detector.
 4. Filter losses were only considered in the spurious frequency bands and the authorized band was not corrected for High Pass Filter losses.
 5. Proper operation of the transmitter prior to adding the filter to the measurement chain.
 6. Owing to the highest peak level of unwanted emission out of the restricted bands are lower than the line(54dBuV/m) in the graph, so all the peak test point was deemed to comply with the limits -27dBm/MHz (68.2dBuV/m) list in the standard CFR 47 FCC §15.407 (b) and ISED RSS-247 6.2.



HARMONICS AND SPURIOUS EMISSIONS (LOW CHANNEL, VERTICAL)

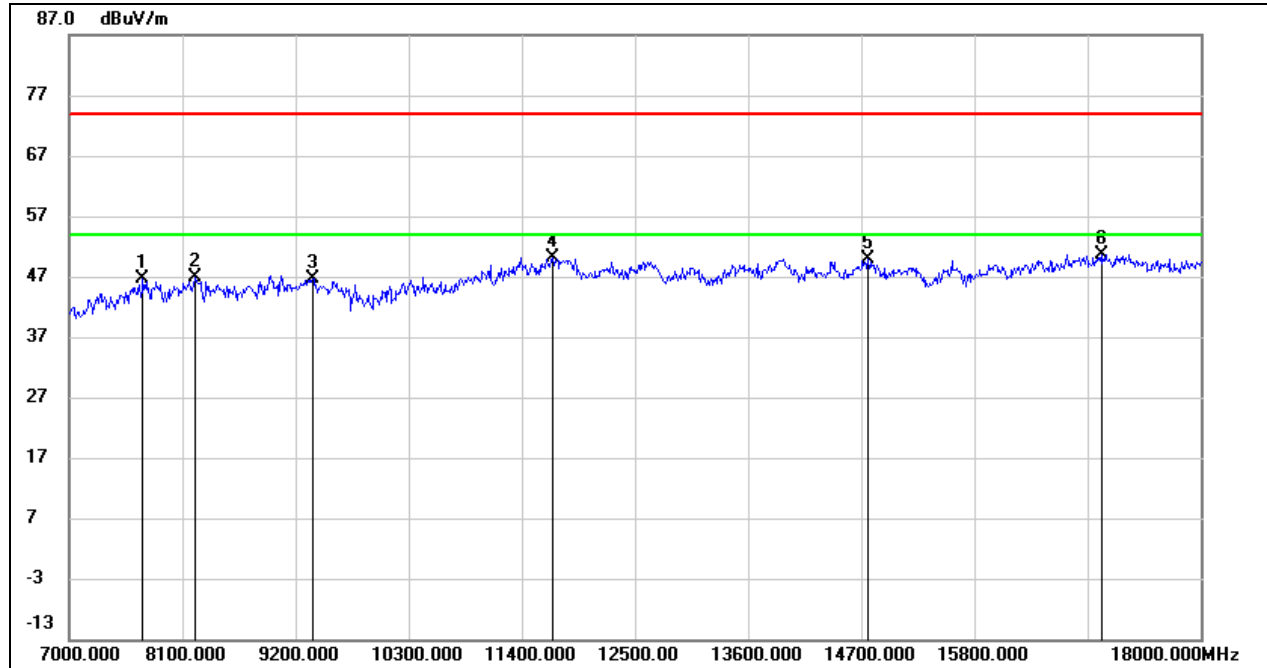

No.	Frequency (MHz)	Reading (dBuV)	Correct (dB/m)	Result (dBuV/m)	Limit (dBuV/m)	Margin (dB)	Remark
1	7715.000	38.81	7.92	46.73	74.00	-27.27	peak
2	8221.000	37.63	9.28	46.91	74.00	-27.09	peak
3	9365.000	36.58	10.13	46.71	74.00	-27.29	peak
4	11697.000	34.99	15.05	50.04	74.00	-23.96	peak
5	14766.000	33.02	16.74	49.76	74.00	-24.24	peak
6	17032.000	30.27	20.36	50.63	74.00	-23.37	peak

Note: 1. Measurement = Reading Level + Correct Factor.
 2. If Peak Result complies with AV limit, AV Result is deemed to comply with AV limit.
 3. Peak: Peak detector.
 4. Filter losses were only considered in the spurious frequency bands and the authorized band was not corrected for High Pass Filter losses.
 5. Proper operation of the transmitter prior to adding the filter to the measurement chain.
 6. Owing to the highest peak level of unwanted emission out of the restricted bands are lower than the line(54dBuV/m) in the graph, so all the peak test point was deemed to comply with the limits -27dBm/MHz (68.2dBuV/m) list in the standard CFR 47 FCC §15.407 (b) and ISED RSS-247 6.2.



UNII-2C BAND

HARMONICS AND SPURIOUS EMISSIONS (LOW CHANNEL, HORIZONTAL)

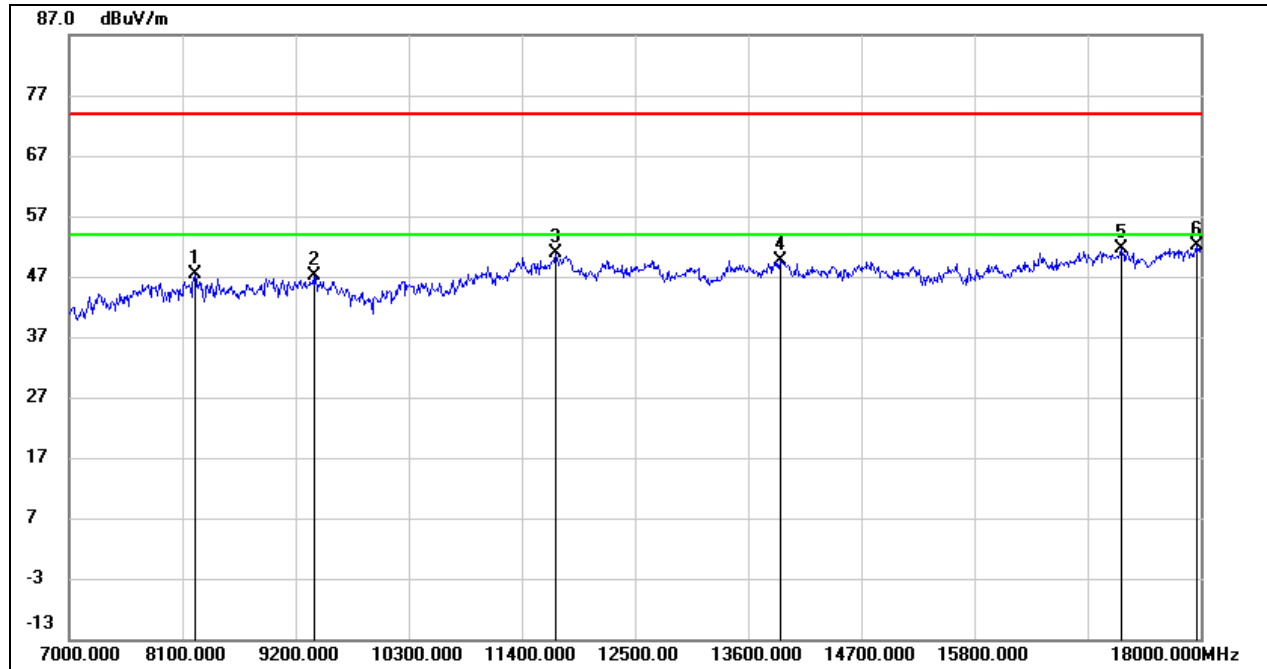

No.	Frequency (MHz)	Reading (dBuV)	Correct (dB/m)	Result (dBuV/m)	Limit (dBuV/m)	Margin (dB)	Remark
1	8221.000	38.14	9.28	47.42	74.00	-26.58	peak
2	9376.000	36.87	10.19	47.06	74.00	-26.94	peak
3	11730.000	35.73	15.23	50.96	74.00	-23.04	peak
4	13908.000	32.64	16.90	49.54	74.00	-24.46	peak
5	17230.000	30.61	20.99	51.60	74.00	-22.40	peak
6	17967.000	29.34	22.67	52.01	74.00	-21.99	peak

Note: 1. Measurement = Reading Level + Correct Factor.
 2. If Peak Result complies with AV limit, AV Result is deemed to comply with AV limit.
 3. Peak: Peak detector.
 4. Filter losses were only considered in the spurious frequency bands and the authorized band was not corrected for High Pass Filter losses.
 5. Proper operation of the transmitter prior to adding the filter to the measurement chain.
 6. Owing to the highest peak level of unwanted emission out of the restricted bands are lower than the line(54dBuV/m) in the graph, so all the peak test point was deemed to comply with the limits -27dBm/MHz (68.2dBuV/m) list in the standard CFR 47 FCC §15.407 (b) and ISED RSS-247 6.2.

HARMONICS AND SPURIOUS EMISSIONS (LOW CHANNEL, VERTICAL)

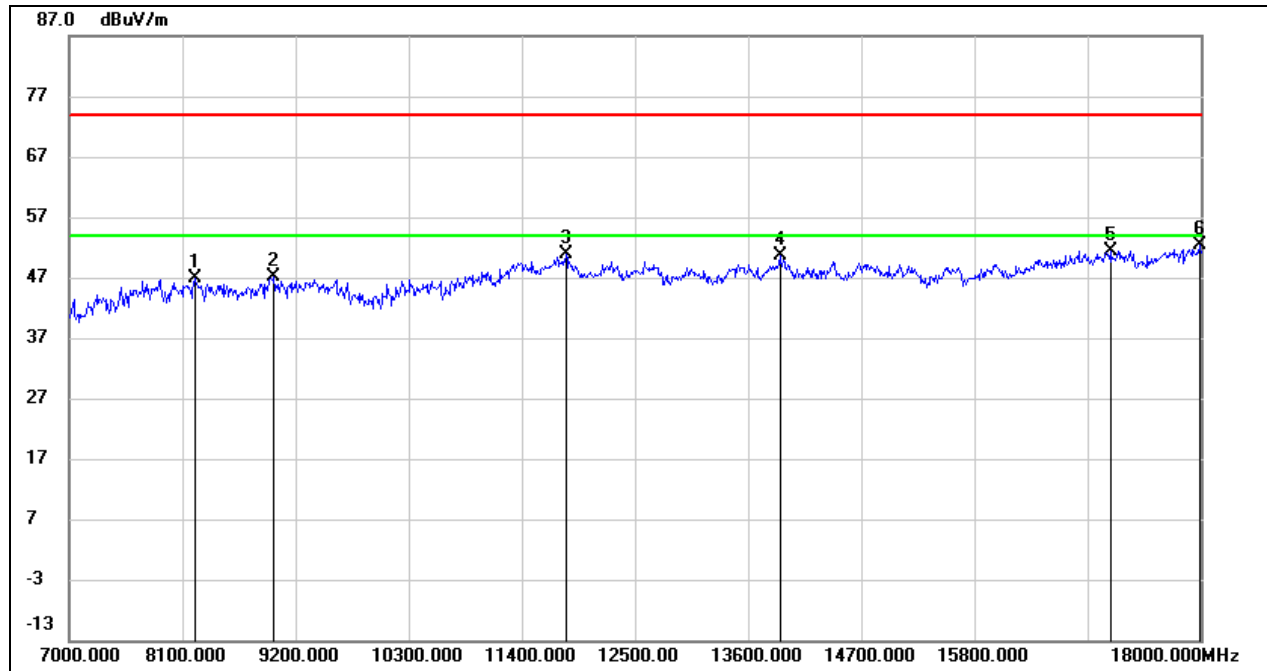

No.	Frequency (MHz)	Reading (dBuV)	Correct (dB/m)	Result (dBuV/m)	Limit (dBuV/m)	Margin (dB)	Remark
1	8221.000	37.67	9.28	46.95	74.00	-27.05	peak
2	8991.000	36.70	10.53	47.23	74.00	-26.77	peak
3	11829.000	35.21	15.57	50.78	74.00	-23.22	peak
4	13908.000	33.70	16.90	50.60	74.00	-23.40	peak
5	17120.000	30.65	20.72	51.37	74.00	-22.63	peak
6	17989.000	29.74	22.67	52.41	74.00	-21.59	peak

Note: 1. Measurement = Reading Level + Correct Factor.
 2. If Peak Result complies with AV limit, AV Result is deemed to comply with AV limit.
 3. Peak: Peak detector.
 4. Filter losses were only considered in the spurious frequency bands and the authorized band was not corrected for High Pass Filter losses.
 5. Proper operation of the transmitter prior to adding the filter to the measurement chain.
 6. Owing to the highest peak level of unwanted emission out of the restricted bands are lower than the line(54dBuV/m) in the graph, so all the peak test point was deemed to comply with the limits -27dBm/MHz (68.2dBuV/m) list in the standard CFR 47 FCC §15.407 (b) and ISED RSS-247 6.2.

HARMONICS AND SPURIOUS EMISSIONS (HIGH CHANNEL, HORIZONTAL)

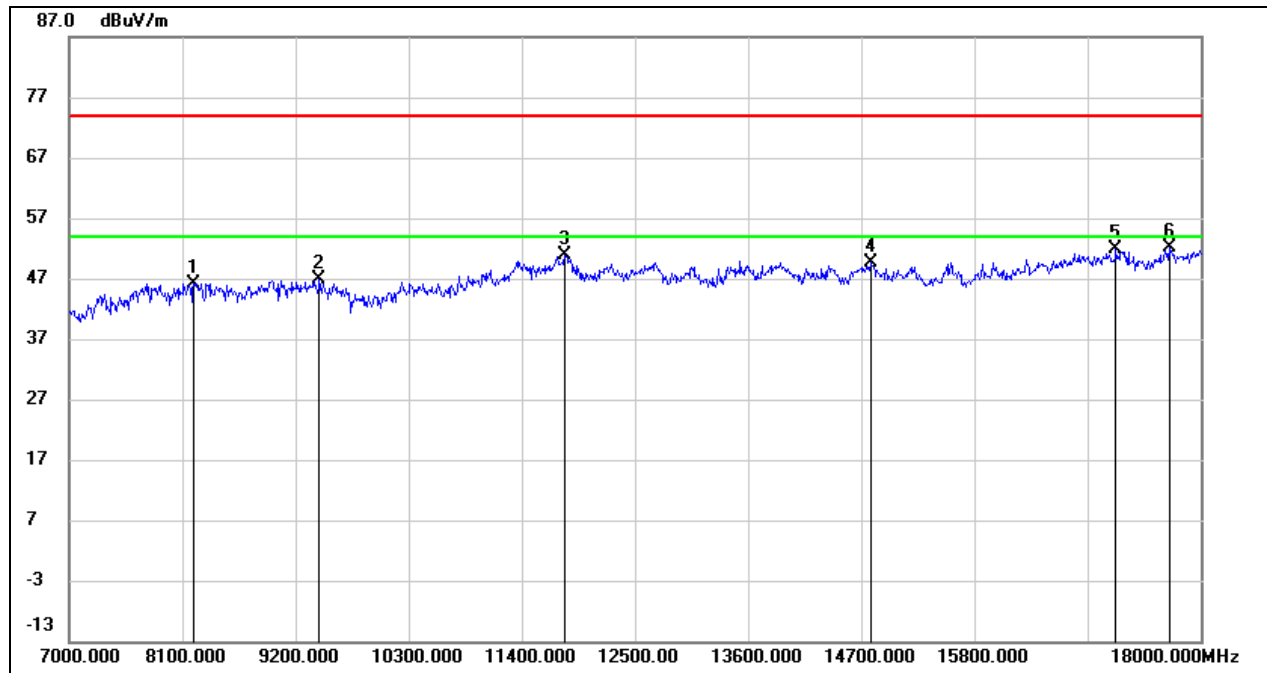

No.	Frequency (MHz)	Reading (dBuV)	Correct (dB/m)	Result (dBuV/m)	Limit (dBuV/m)	Margin (dB)	Remark
1	8210.000	36.79	9.32	46.11	74.00	-27.89	peak
2	9431.000	36.48	10.35	46.83	74.00	-27.17	peak
3	11818.000	35.37	15.58	50.95	74.00	-23.05	peak
4	14799.000	32.90	16.80	49.70	74.00	-24.30	peak
5	17175.000	30.86	20.94	51.80	74.00	-22.20	peak
6	17692.000	30.16	21.87	52.03	74.00	-21.97	peak

Note: 1. Measurement = Reading Level + Correct Factor.
 2. If Peak Result complies with AV limit, AV Result is deemed to comply with AV limit.
 3. Peak: Peak detector.
 4. Filter losses were only considered in the spurious frequency bands and the authorized band was not corrected for High Pass Filter losses.
 5. Proper operation of the transmitter prior to adding the filter to the measurement chain.
 6. Owing to the highest peak level of unwanted emission out of the restricted bands are lower than the line(54dBuV/m) in the graph, so all the peak test point was deemed to comply with the limits -27dBm/MHz (68.2dBuV/m) list in the standard CFR 47 FCC §15.407 (b) and ISED RSS-247 6.2.

HARMONICS AND SPURIOUS EMISSIONS (HIGH CHANNEL, VERTICAL)

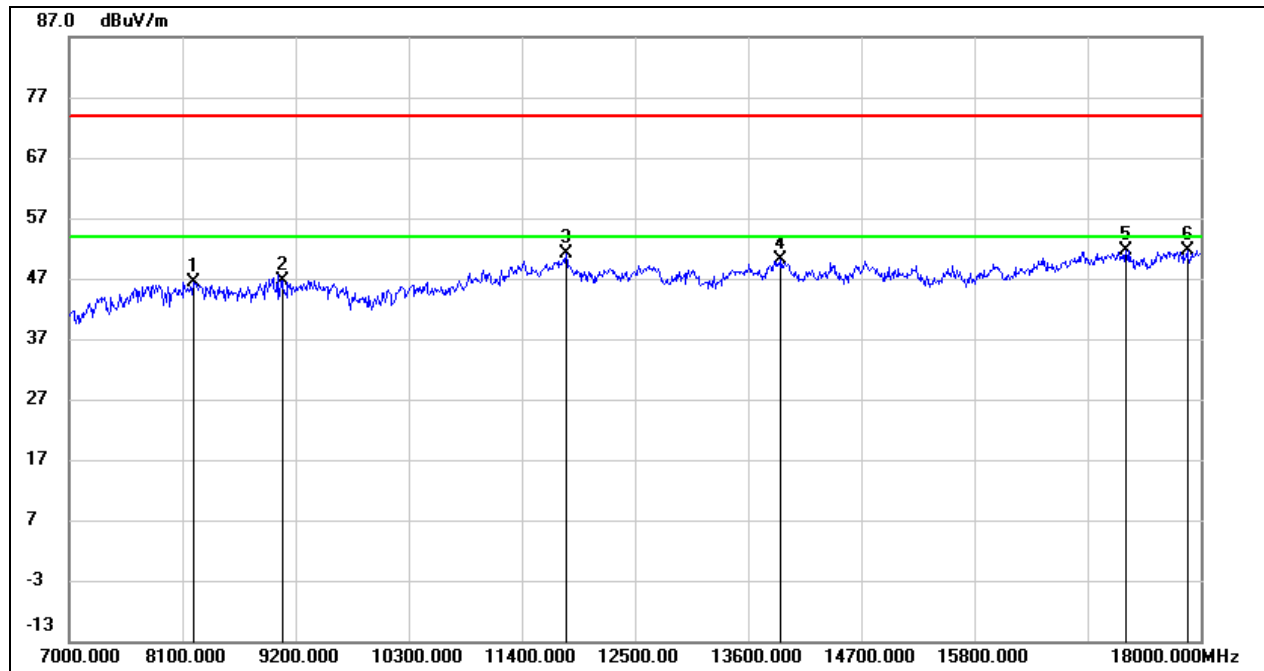

No.	Frequency (MHz)	Reading (dBuV)	Correct (dB/m)	Result (dBuV/m)	Limit (dBuV/m)	Margin (dB)	Remark
1	8210.000	37.06	9.32	46.38	74.00	-27.62	peak
2	9068.000	36.52	10.17	46.69	74.00	-27.31	peak
3	11829.000	35.63	15.57	51.20	74.00	-22.80	peak
4	13919.000	33.13	16.89	50.02	74.00	-23.98	peak
5	17274.000	30.59	20.93	51.52	74.00	-22.48	peak
6	17868.000	29.02	22.71	51.73	74.00	-22.27	peak

Note: 1. Measurement = Reading Level + Correct Factor.
 2. If Peak Result complies with AV limit, AV Result is deemed to comply with AV limit.
 3. Peak: Peak detector.
 4. Filter losses were only considered in the spurious frequency bands and the authorized band was not corrected for High Pass Filter losses.
 5. Proper operation of the transmitter prior to adding the filter to the measurement chain.
 6. Owing to the highest peak level of unwanted emission out of the restricted bands are lower than the line(54dBuV/m) in the graph, so all the peak test point was deemed to comply with the limits -27dBm/MHz (68.2dBuV/m) list in the standard CFR 47 FCC §15.407 (b) and ISED RSS-247 6.2.



STRADDLE CHANNEL 138

HARMONICS AND SPURIOUS EMISSIONS (HIGH CHANNEL, HORIZONTAL)

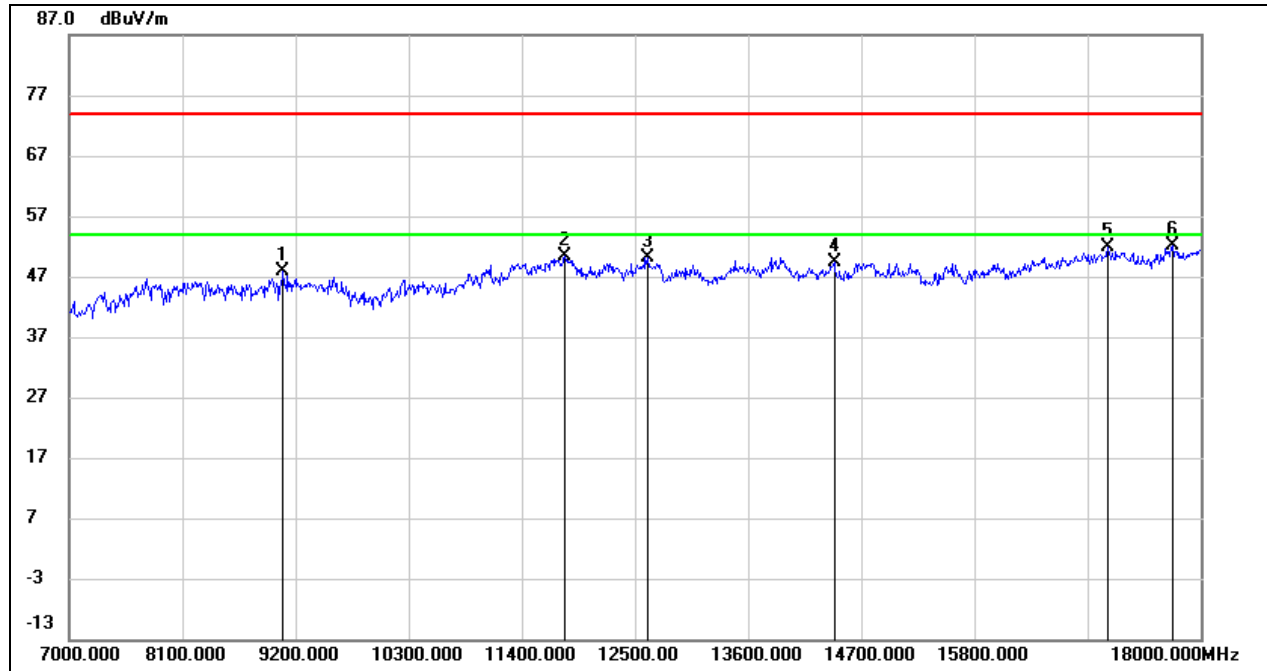

No.	Frequency (MHz)	Reading (dBuV)	Correct (dB/m)	Result (dBuV/m)	Limit (dBuV/m)	Margin (dB)	Remark
1	9079.000	37.84	10.10	47.94	74.00	-26.06	peak
2	11818.000	34.70	15.58	50.28	74.00	-23.72	peak
3	12621.000	34.87	15.33	50.20	74.00	-23.80	peak
4	14436.000	32.69	16.79	49.48	74.00	-24.52	peak
5	17098.000	31.14	20.63	51.77	74.00	-22.23	peak
6	17725.000	30.09	22.13	52.22	74.00	-21.78	peak

Note: 1. Measurement = Reading Level + Correct Factor.
 2. If Peak Result complies with AV limit, AV Result is deemed to comply with AV limit.
 3. Peak: Peak detector.
 4. Filter losses were only considered in the spurious frequency bands and the authorized band was not corrected for High Pass Filter losses.
 5. Proper operation of the transmitter prior to adding the filter to the measurement chain.
 6. Owing to the highest peak level of unwanted emission out of the restricted bands are lower than the line(54dBuV/m) in the graph, so all the peak test point was deemed to comply with the limits -27dBm/MHz (68.2dBuV/m) list in the standard CFR 47 FCC §15.407 (b) and ISED RSS-247 6.2.



HARMONICS AND SPURIOUS EMISSIONS (HIGH CHANNEL, VERTICAL)

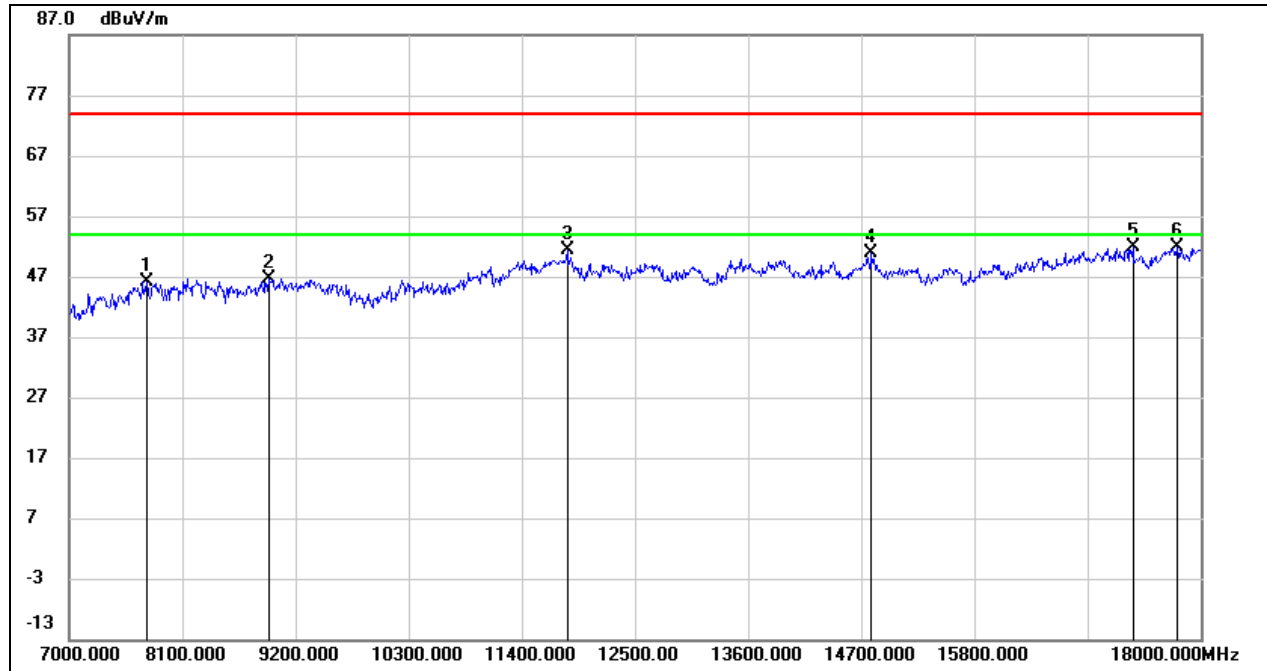

No.	Frequency (MHz)	Reading (dBuV)	Correct (dB/m)	Result (dBuV/m)	Limit (dBuV/m)	Margin (dB)	Remark
1	7748.000	38.19	8.05	46.24	74.00	-27.76	peak
2	8947.000	36.61	10.07	46.68	74.00	-27.32	peak
3	11840.000	35.75	15.56	51.31	74.00	-22.69	peak
4	14799.000	34.00	16.80	50.80	74.00	-23.20	peak
5	17340.000	31.00	20.82	51.82	74.00	-22.18	peak
6	17769.000	29.46	22.48	51.94	74.00	-22.06	peak

Note: 1. Measurement = Reading Level + Correct Factor.
 2. If Peak Result complies with AV limit, AV Result is deemed to comply with AV limit.
 3. Peak: Peak detector.
 4. Filter losses were only considered in the spurious frequency bands and the authorized band was not corrected for High Pass Filter losses.
 5. Proper operation of the transmitter prior to adding the filter to the measurement chain.
 6. Owing to the highest peak level of unwanted emission out of the restricted bands are lower than the line(54dBuV/m) in the graph, so all the peak test point was deemed to comply with the limits -27dBm/MHz (68.2dBuV/m) list in the standard CFR 47 FCC §15.407 (b) and ISED RSS-247 6.2.

UNII-3 BAND

HARMONICS AND SPURIOUS EMISSIONS (LOW CHANNEL, HORIZONTAL)

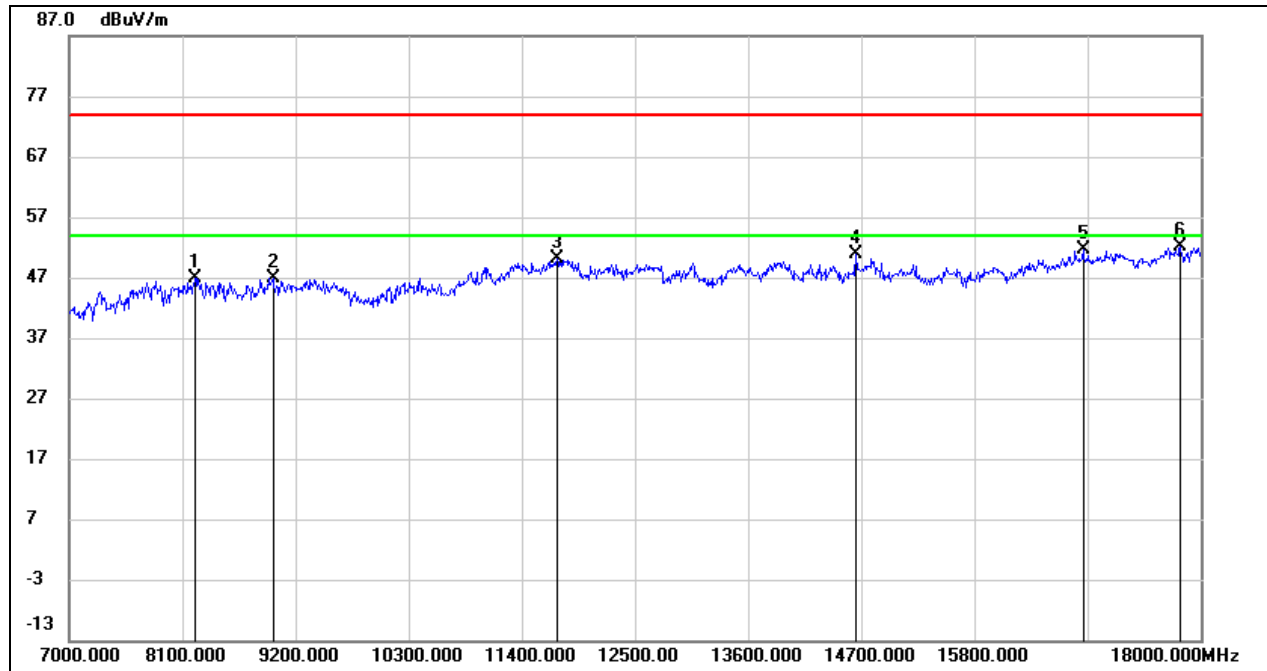

No.	Frequency (MHz)	Reading (dBuV)	Correct (dB/m)	Result (dBuV/m)	Limit (dBuV/m)	Margin (dB)	Remark
1	8221.000	37.61	9.28	46.89	74.00	-27.11	peak
2	8980.000	36.53	10.41	46.94	74.00	-27.06	peak
3	11741.000	34.82	15.28	50.10	74.00	-23.90	peak
4	14645.000	34.25	16.54	50.79	74.00	-23.21	peak
5	16856.000	31.69	19.87	51.56	74.00	-22.44	peak
6	17802.000	29.52	22.72	52.24	74.00	-21.76	peak

Note: 1. Measurement = Reading Level + Correct Factor.
 2. If Peak Result complies with AV limit, AV Result is deemed to comply with AV limit.
 3. Peak: Peak detector.
 4. Filter losses were only considered in the spurious frequency bands and the authorized band was not corrected for High Pass Filter losses.
 5. Proper operation of the transmitter prior to adding the filter to the measurement chain.
 6. Owing to the highest peak level of unwanted emission out of the restricted bands are lower than the line(54dBuV/m) in the graph, so all the peak test point was deemed to comply with the limits -27dBm/MHz (68.2dBuV/m) list in the standard CFR 47 FCC §15.407 (b) and ISED RSS-247 6.2.



HARMONICS AND SPURIOUS EMISSIONS (LOW CHANNEL, VERTICAL)

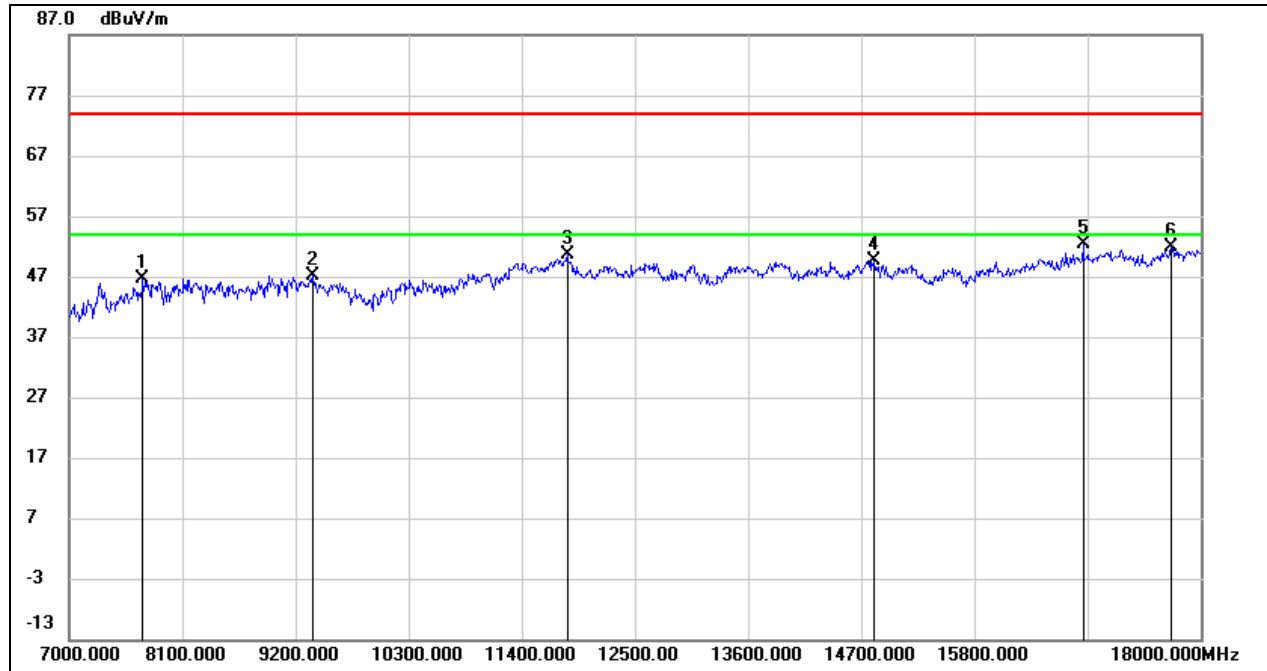

No.	Frequency (MHz)	Reading (dBuV)	Correct (dB/m)	Result (dBuV/m)	Limit (dBuV/m)	Margin (dB)	Remark
1	7715.000	38.63	7.92	46.55	74.00	-27.45	peak
2	9365.000	37.05	10.13	47.18	74.00	-26.82	peak
3	11840.000	35.10	15.56	50.66	74.00	-23.34	peak
4	14821.000	32.80	16.81	49.61	74.00	-24.39	peak
5	16856.000	32.39	19.87	52.26	74.00	-21.74	peak
6	17714.000	29.76	22.04	51.80	74.00	-22.20	peak

Note: 1. Measurement = Reading Level + Correct Factor.
 2. If Peak Result complies with AV limit, AV Result is deemed to comply with AV limit.
 3. Peak: Peak detector.
 4. Filter losses were only considered in the spurious frequency bands and the authorized band was not corrected for High Pass Filter losses.
 5. Proper operation of the transmitter prior to adding the filter to the measurement chain.
 6. Owing to the highest peak level of unwanted emission out of the restricted bands are lower than the line(54dBuV/m) in the graph, so all the peak test point was deemed to comply with the limits -27dBm/MHz (68.2dBuV/m) list in the standard CFR 47 FCC §15.407 (b) and ISED RSS-247 6.2.

8.4. SPURIOUS EMISSIONS (18 GHz ~ 26 GHz)

8.4.1. 802.11ac VHT80 MODE

SPURIOUS EMISSIONS (UNII-2C BAND LOW CHANNEL, HORIZONTAL, WORST-CASE CONFIGURATION)

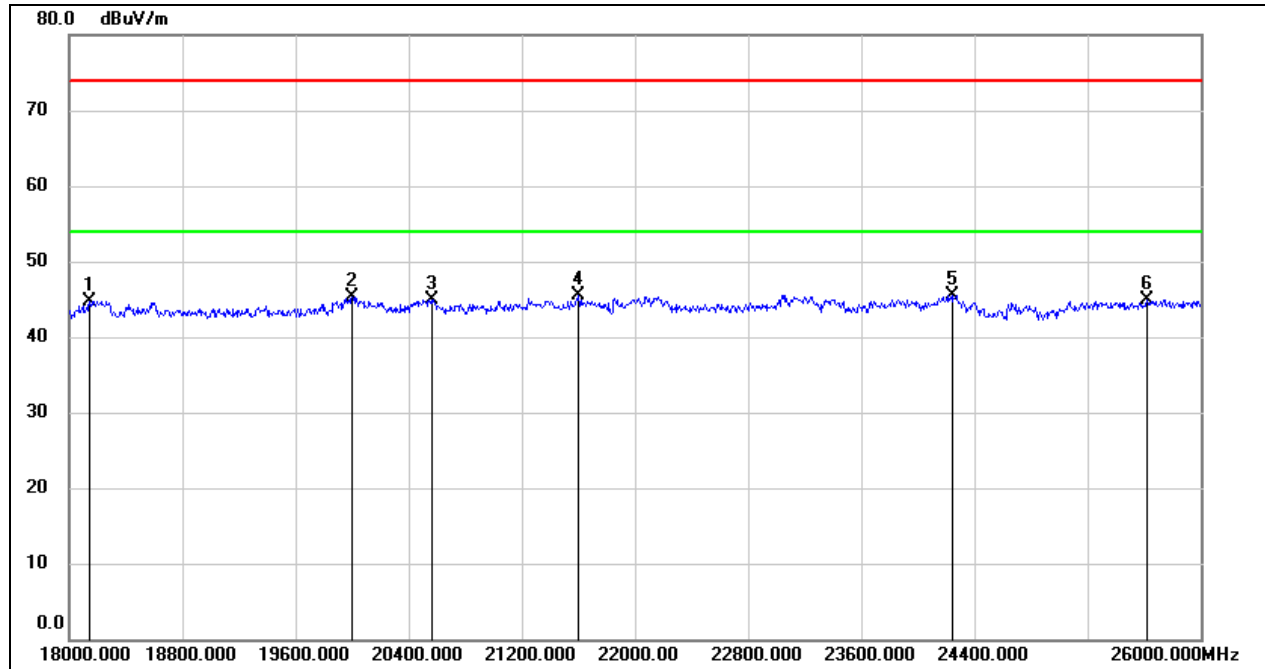

No.	Frequency (MHz)	Reading (dBuV)	Correct (dB/m)	Result (dBuV/m)	Limit (dBuV/m)	Margin (dB)	Remark
1	18144.000	50.27	-5.48	44.79	74.00	-29.21	peak
2	20000.000	50.81	-5.45	45.36	74.00	-28.64	peak
3	20560.000	50.23	-5.30	44.93	74.00	-29.07	peak
4	21600.000	50.02	-4.54	45.48	74.00	-28.52	peak
5	24248.000	48.32	-2.83	45.49	74.00	-28.51	peak
6	25616.000	46.18	-1.24	44.94	74.00	-29.06	peak

Note: 1. Measurement = Reading Level + Correct Factor.
 2. If Peak Result complies with AV limit, AV Result is deemed to comply with AV limit.
 3. Peak: Peak detector.
 4. The preamplifier only effect to the above 18GHz signal and no filter added to the measurement chain.

SPURIOUS EMISSIONS (UNII-2C BAND LOW CHANNEL, VERTICAL, WORST-CASE CONFIGURATION)

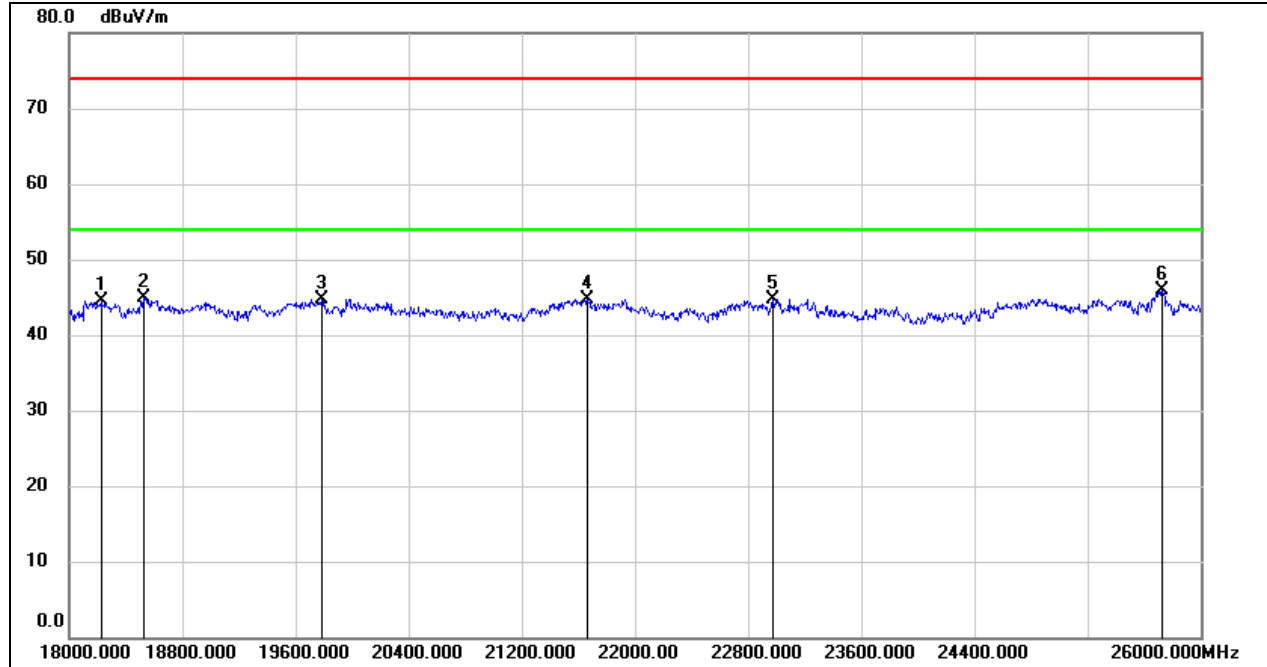

No.	Frequency (MHz)	Reading (dBuV)	Correct (dB/m)	Result (dBuV/m)	Limit (dBuV/m)	Margin (dB)	Remark
1	18224.000	50.08	-5.53	44.55	74.00	-29.45	peak
2	18528.000	50.11	-5.26	44.85	74.00	-29.15	peak
3	19784.000	50.07	-5.28	44.79	74.00	-29.21	peak
4	21664.000	49.23	-4.45	44.78	74.00	-29.22	peak
5	22976.000	48.26	-3.46	44.80	74.00	-29.20	peak
6	25728.000	46.61	-0.72	45.89	74.00	-28.11	peak

Note: 1. Measurement = Reading Level + Correct Factor.
 2. If Peak Result complies with AV limit, AV Result is deemed to comply with AV limit.
 3. Peak: Peak detector.
 4. The preamplifier only effect to the above 18GHz signal and no filter added to the measurement chain.

Note: All the modes, antennas and channels had been tested, but only the worst data was recorded in the report.



8.5. SPURIOUS EMISSIONS (26 GHz ~ 40 GHz)

8.5.1. 802.11ac VHT80 MODE

SPURIOUS EMISSIONS (UNII-2C BAND LOW CHANNEL, HORIZONTAL, WORST-CASE CONFIGURATION)

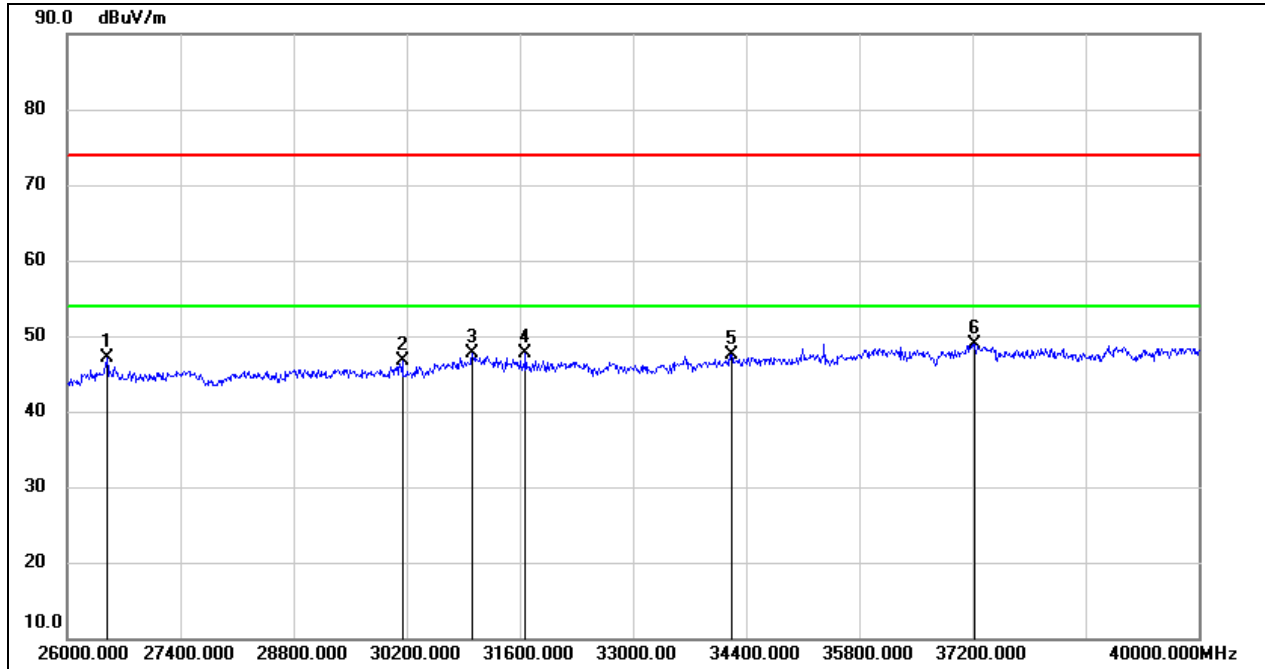

No.	Frequency (MHz)	Reading (dBuV)	Correct (dB/m)	Result (dBuV/m)	Limit (dBuV/m)	Margin (dB)	Remark
1	26490.000	51.79	-4.74	47.05	74.00	-26.95	peak
2	30144.000	47.96	-1.30	46.66	74.00	-27.34	peak
3	31012.000	48.33	-0.71	47.62	74.00	-26.38	peak
4	31670.000	48.86	-1.21	47.65	74.00	-26.35	peak
5	34218.000	46.46	1.13	47.59	74.00	-26.41	peak
6	37228.000	45.73	3.14	48.87	74.00	-25.13	peak

Note: 1. Measurement = Reading Level + Correct Factor.
 2. If Peak Result complies with AV limit, AV Result is deemed to comply with AV limit.
 3. Peak: Peak detector.
 4. The preamplifier only effect to the above 18GHz signal and no filter added to the measurement chain.



SPURIOUS EMISSIONS (UNII-2C BAND LOW CHANNEL, VERTICAL, WORST-CASE CONFIGURATION)

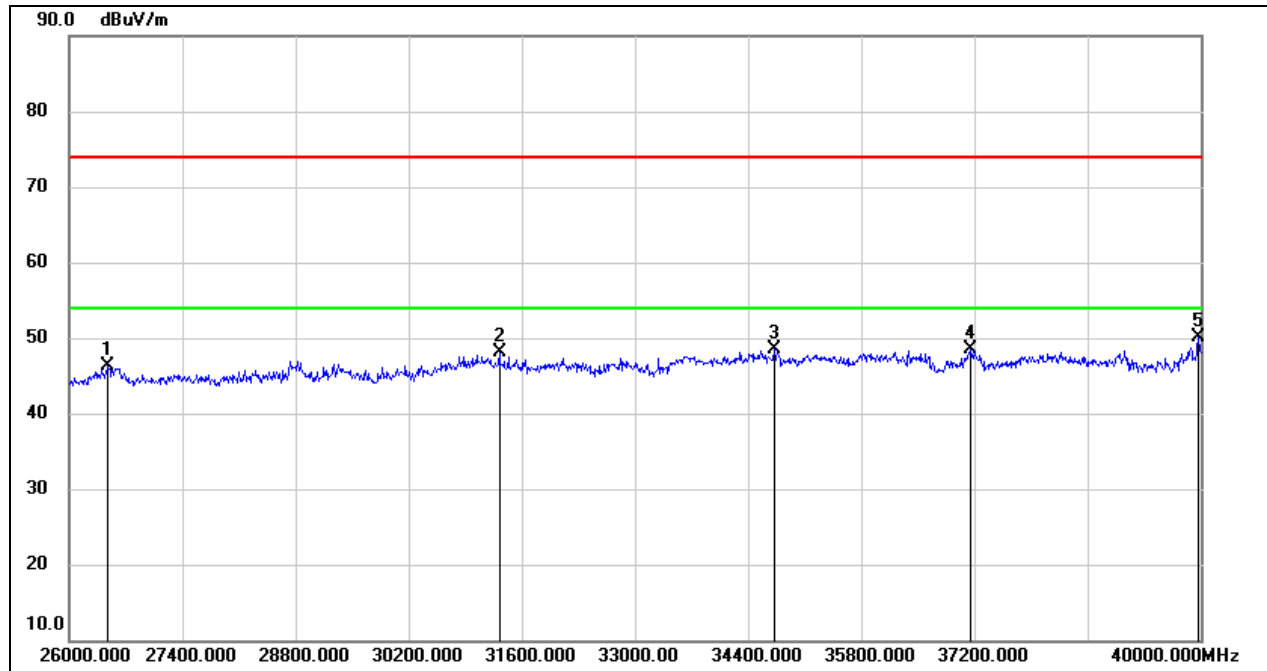

No.	Frequency (MHz)	Reading (dBuV)	Correct (dB/m)	Result (dBuV/m)	Limit (dBuV/m)	Margin (dB)	Remark
1	26476.000	51.03	-4.78	46.25	74.00	-27.75	peak
2	31320.000	49.11	-0.93	48.18	74.00	-25.82	peak
3	34722.000	46.94	1.48	48.42	74.00	-25.58	peak
4	37158.000	45.34	3.17	48.51	74.00	-25.49	peak
5	39972.000	44.95	5.13	50.08	74.00	-23.92	peak

Note: 1. Measurement = Reading Level + Correct Factor.
 2. If Peak Result complies with AV limit, AV Result is deemed to comply with AV limit.
 3. Peak: Peak detector.
 4. The preamplifier only effect to the above 18GHz signal and no filter added to the measurement chain.

Note: All the modes, antennas and channels had been tested, but only the worst data was recorded in the report.



8.6. SPURIOUS EMISSIONS (30 MHz ~ 1 GHz)

8.6.1. 802.11ac VHT80 MODE

SPURIOUS EMISSIONS (UNII-2C BAND LOW CHANNEL, HORIZONTAL, WORST-CASE CONFIGURATION)

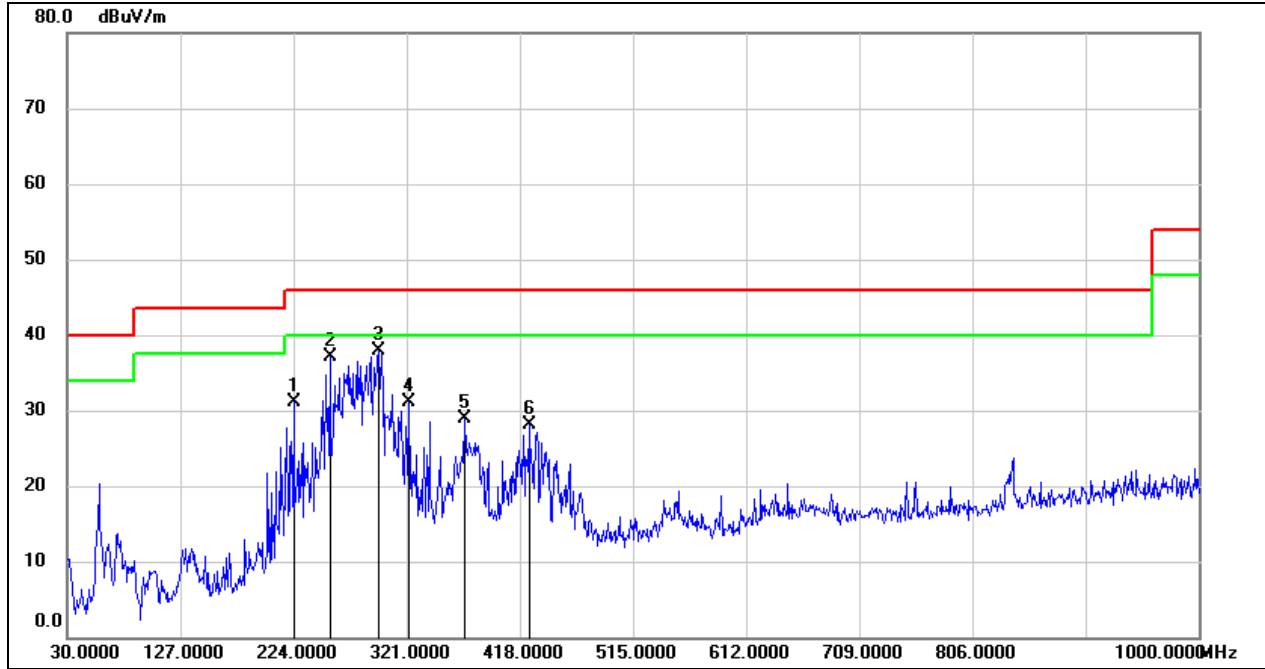

No.	Frequency (MHz)	Reading (dBuV)	Correct (dB/m)	Result (dBuV/m)	Limit (dBuV/m)	Margin (dB)	Remark
1	224.0000	49.45	-18.37	31.08	46.00	-14.92	QP
2	255.0400	55.76	-18.73	37.03	46.00	-8.97	QP
3	296.7500	53.34	-15.50	37.84	46.00	-8.16	QP
4	322.9400	45.78	-14.75	31.03	46.00	-14.97	QP
5	370.4700	42.82	-13.94	28.88	46.00	-17.12	QP
6	425.7600	41.01	-12.83	28.18	46.00	-17.82	QP

- Note: 1. Result Level = Read Level + Correct Factor.
 2. If Peak Result complies with QP limit, QP Result is deemed to comply with QP limit.
 3. Test setup: RBW: 120 kHz, VBW: 300 kHz, Sweep time: auto.



SPURIOUS EMISSIONS (UNII-2C BAND LOW CHANNEL, VERTICAL, WORST-CASE CONFIGURATION)

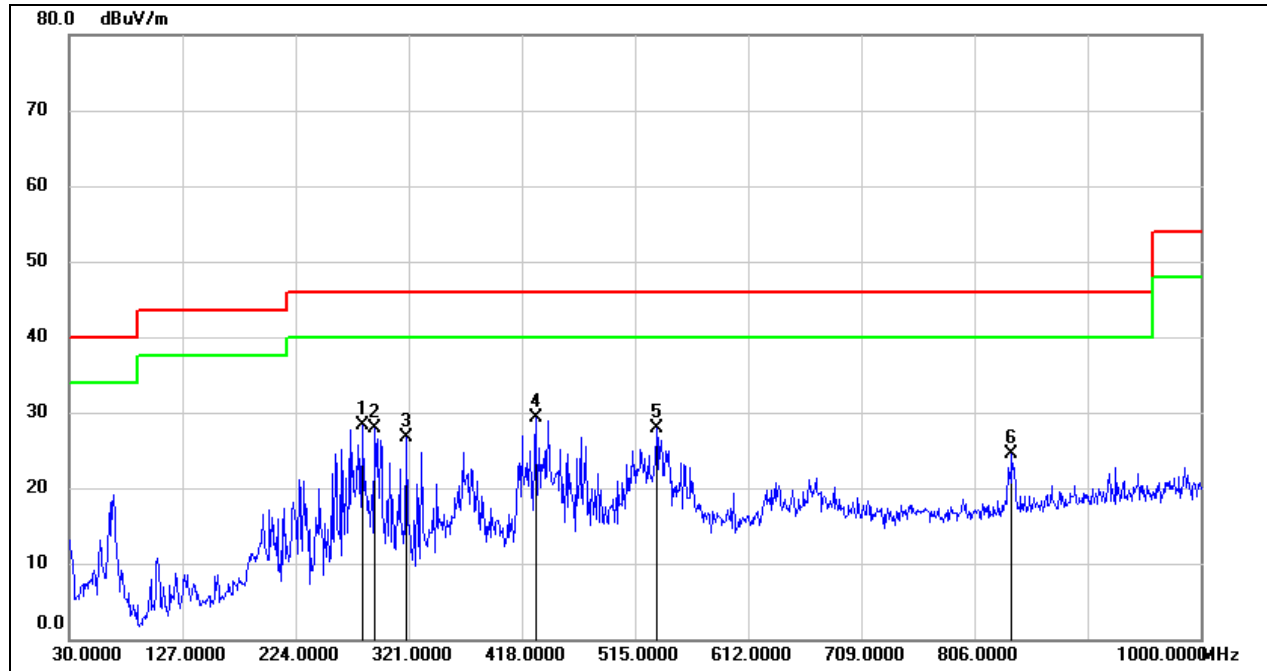

No.	Frequency (MHz)	Reading (dBuV)	Correct (dB/m)	Result (dBuV/m)	Limit (dBuV/m)	Margin (dB)	Remark
1	281.2300	44.87	-16.59	28.28	46.00	-17.72	QP
2	291.9000	43.72	-15.80	27.92	46.00	-18.08	QP
3	319.0600	41.44	-14.80	26.64	46.00	-19.36	QP
4	429.6400	42.05	-12.73	29.32	46.00	-16.68	QP
5	533.4300	38.61	-10.70	27.91	46.00	-18.09	QP
6	838.0100	31.10	-6.52	24.58	46.00	-21.42	QP

- Note: 1. Result Level = Read Level + Correct Factor.
 2. If Peak Result complies with QP limit, QP Result is deemed to comply with QP limit.
 3. Test setup: RBW: 120 kHz, VBW: 300 kHz, Sweep time: auto

Note: All the modes, antennas and channels had been tested, but only the worst data was recorded in the report.

8.7. SPURIOUS EMISSIONS BELOW 30 MHz

8.7.1. 802.11ac VHT80 MODE

SPURIOUS EMISSIONS (UNII-2C BAND LOW CHANNEL, LOOP ANTENNA FACE ON TO THE EUT, WORST-CASE CONFIGURATION)

9 kHz~ 150 kHz

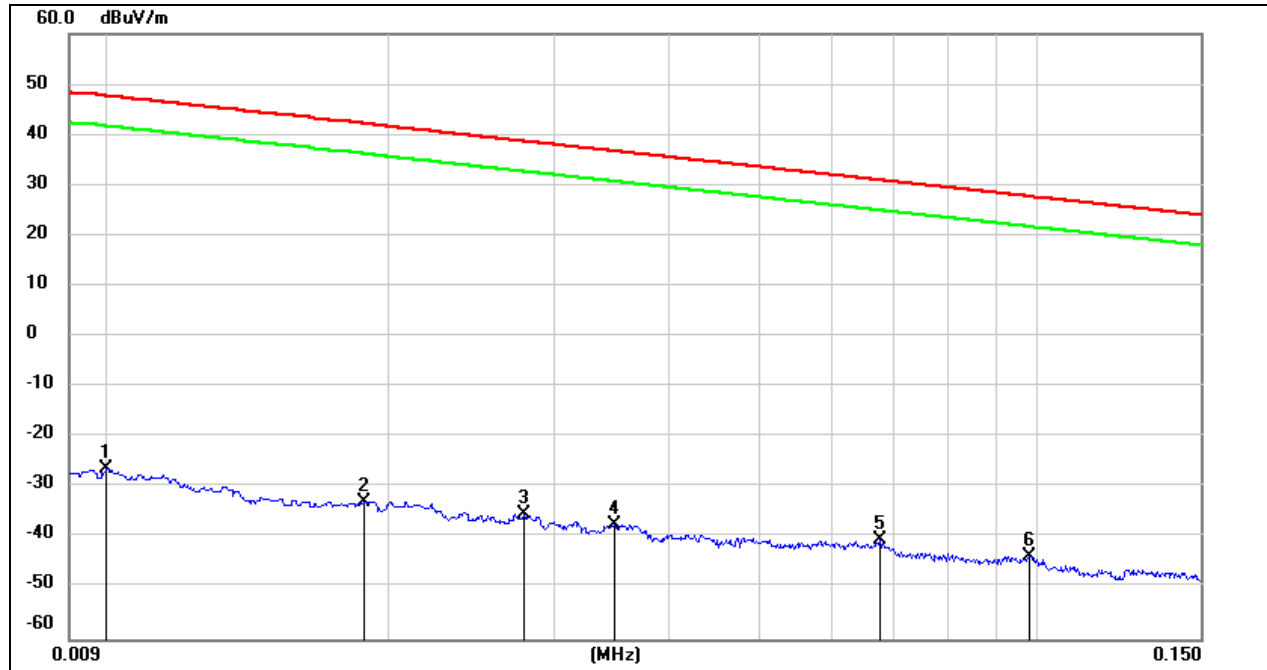

No.	Frequency (MHz)	Reading (dBuV)	Correct (dB/m)	FCC Result (dBuV/m)	FCC Limit (dBuV/m)	ISED Result (dBuA/m)	ISED Limit (dBuA/m)	Margin (dB)	Remark
1	0.0100	75.22	-101.40	-26.18	47.6	-77.68	-3.90	-73.78	peak
2	0.0188	68.64	-101.35	-32.71	42.12	-84.21	-9.38	-74.83	peak
3	0.0279	66.17	-101.38	-35.21	38.69	-86.71	-12.81	-73.90	peak
4	0.0349	64.03	-101.41	-37.38	36.75	-88.88	-14.75	-74.13	peak
5	0.0675	61.14	-101.56	-40.42	31.02	-91.92	-20.48	-71.44	peak
6	0.0981	58.27	-101.78	-43.51	27.77	-95.01	-23.73	-71.28	peak

Note: 1. Measurement = Reading Level + Correct Factor.

2. If Peak Result complies with AV and QP limit, AV and QP Result are deemed to comply with AV limit.

3. All 3 polarizations (Horizontal, Face-on and Face-off) of the loop antenna had been tested, but only the worst data recorded in the report.

4. $\text{dBuA/m} = \text{dBuV/m} - 20\log_{10}(120\pi) = \text{dBuV/m} - 51.5$.

150 kHz ~ 490 kHz

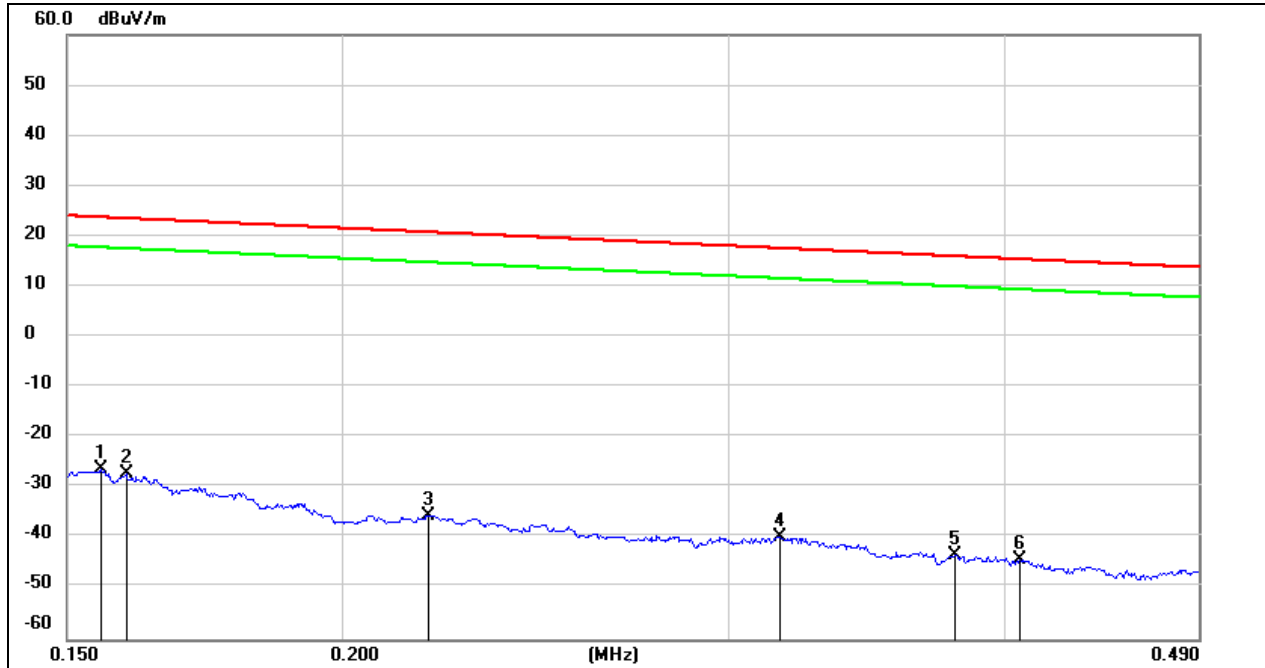

No.	Frequency (MHz)	Reading (dBuV)	Correct (dB/m)	FCC Result (dBuV/m)	FCC Limit (dBuV/m)	ISED Result (dBuA/m)	ISED Limit (dBuA/m)	Margin (dB)	Remark
1	0.1554	75.27	-101.65	-26.38	23.77	-77.88	-27.73	-50.15	peak
2	0.1595	74.36	-101.65	-27.29	23.55	-78.79	-27.95	-50.84	peak
3	0.2190	66.27	-101.75	-35.48	20.79	-86.98	-30.71	-56.27	peak
4	0.3163	62.20	-101.87	-39.67	17.6	-91.17	-33.90	-57.27	peak
5	0.3800	58.52	-101.94	-43.42	16.01	-94.92	-35.49	-59.43	peak
6	0.4062	57.64	-101.96	-44.32	15.43	-95.82	-36.07	-59.75	peak

Note: 1. Measurement = Reading Level + Correct Factor.

2. If Peak Result complies with AV and QP limit, AV and QP Result are deemed to comply with AV limit.

3. All 3 polarizations (Horizontal, Face-on and Face-off) of the loop antenna had been tested, but only the worst data recorded in the report.

4. $\text{dBuA/m} = \text{dBuV/m} - 20\log_{10}(120\pi) = \text{dBuV/m} - 51.5$.



490 kHz ~ 30 MHz

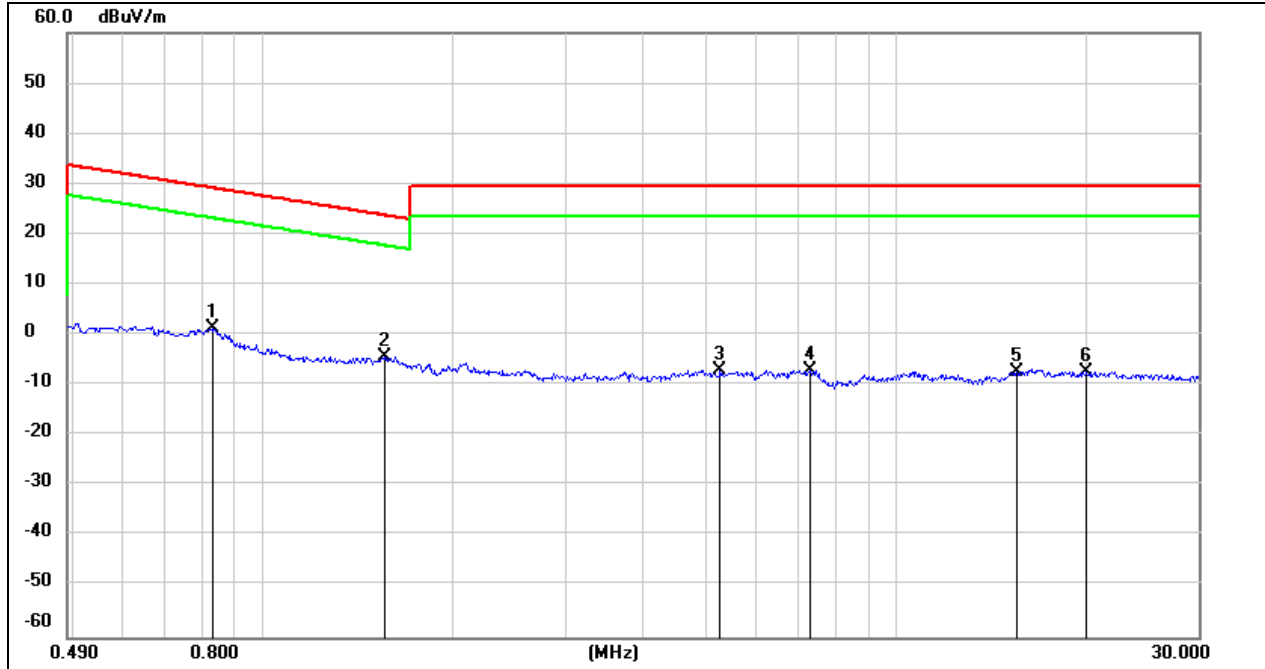

No.	Frequency (MHz)	Reading (dBuV)	Correct (dB/m)	FCC Result (dBuV/m)	FCC Limit (dBuV/m)	ISED Result (dBuA/m)	ISED Limit (dBuA/m)	Margin (dB)	Remark
1	0.8296	63.44	-62.17	1.27	29.23	-50.23	-22.27	-27.96	peak
2	1.5564	57.68	-62.02	-4.34	23.76	-55.84	-27.74	-28.10	peak
3	5.2705	54.54	-61.45	-6.91	29.54	-58.41	-21.96	-36.45	peak
4	7.3361	54.08	-61.17	-7.09	29.54	-58.59	-21.96	-36.63	peak
5	15.4809	53.70	-61.00	-7.3	29.54	-58.80	-21.96	-36.84	peak
6	19.9954	53.44	-60.83	-7.39	29.54	-58.89	-21.96	-36.93	peak

Note: 1. Measurement = Reading Level + Correct Factor.

2. If Peak Result complies with AV and QP limit, AV and QP Result are deemed to comply with AV limit.

3. All 3 polarizations (Horizontal, Face-on and Face-off) of the loop antenna had been tested, but only the worst data recorded in the report.

4. $\text{dBuA/m} = \text{dBuV/m} - 20\log_{10}(120\pi) = \text{dBuV/m} - 51.5$.

Note: All the modes, antennas and channels had been tested, but only the worst data was recorded in the report.

9. AC POWER LINE CONDUCTED EMISSIONS

LIMITS

Please refer to CFR 47 FCC §15.207 (a) and ISED RSS-Gen Clause 8.8

FREQUENCY (MHz)	Quasi-peak	Average
0.15 -0.5	66 - 56 *	56 - 46 *
0.50 -5.0	56.00	46.00
5.0 -30.0	60.00	50.00

TEST SETUP AND PROCEDURE

Refer to ANSI C63.10-2013 clause 6.2.

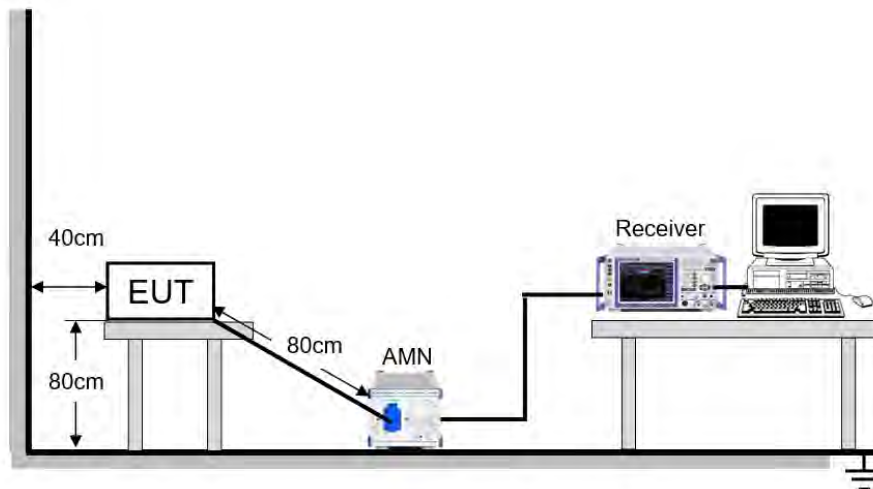

The EUT is put on a table of non-conducting material that is 80 cm high. The vertical conducting wall of shielding is located 40 cm to the rear of the EUT. The power line of the EUT is connected to the AC mains through a Artificial Mains Network (A.M.N.). A EMI Measurement Receiver (R&S Test Receiver ESR3) is used to test the emissions from both sides of AC line. According to the requirements in Section 6.2 of ANSI C63.10-2013. Conducted emissions from the EUT measured in the frequency range between 0.15 MHz and 30 MHz using CISPR Quasi-Peak and average detector mode. The bandwidth of EMI test receiver is set at 9 kHz.

The arrangement of the equipment is installed to meet the standards and operating in a manner, which tends to maximize its emission characteristics in a normal application.

TEST ENVIRONMENT

Temperature	25.3 °C	Relative Humidity	65.3 %
Atmosphere Pressure	101 kPa	Test Voltage	DC 5 V



RESULTS

9.1.1. 802.11ac VHT80 MODE

LINE N RESULTS (UNII-2C BAND LOW CHANNEL, WORST-CASE CONFIGURATION)

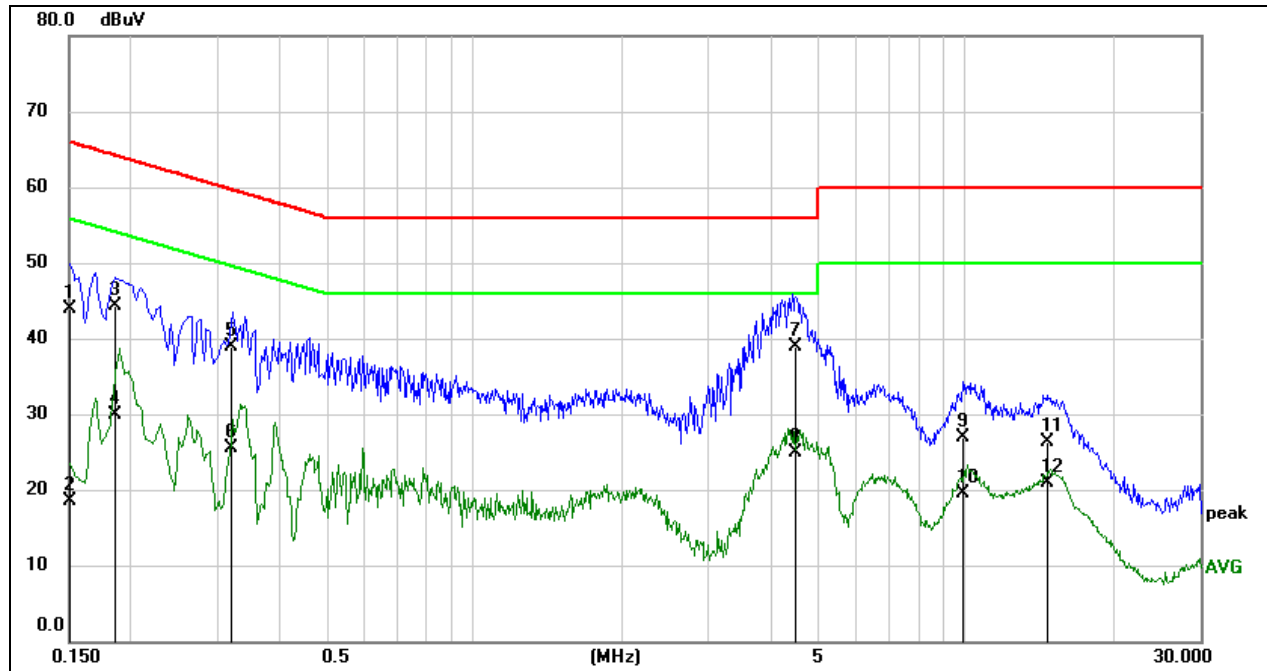

No.	Frequency (MHz)	Reading (dBuV)	Correct (dB)	Result (dBuV)	Limit (dBuV)	Margin (dB)	Remark
1	0.1500	34.41	9.59	44.00	66.00	-22.00	QP
2	0.1500	8.87	9.59	18.46	56.00	-37.54	AVG
3	0.1853	34.68	9.59	44.27	64.24	-19.97	QP
4	0.1853	20.40	9.59	29.99	54.24	-24.25	AVG
5	0.3200	29.38	9.59	38.97	59.71	-20.74	QP
6	0.3200	15.87	9.59	25.46	49.71	-24.25	AVG
7	4.4950	29.37	9.61	38.98	56.00	-17.02	QP
8	4.4950	15.26	9.61	24.87	46.00	-21.13	AVG
9	9.8454	17.32	9.62	26.94	60.00	-33.06	QP
10	9.8454	9.89	9.62	19.51	50.00	-30.49	AVG
11	14.6596	16.57	9.66	26.23	60.00	-33.77	QP
12	14.6596	11.19	9.66	20.85	50.00	-29.15	AVG

Note: 1. Result = Reading + Correct Factor.
 2. If QP Result complies with AV limit, AV Result is deemed to comply with AV limit.
 3. Test setup: RBW: 200 Hz (9 kHz ~ 150 kHz), 9 kHz (150 kHz ~ 30 MHz).
 4. Step size: 80 Hz (0.009 MHz ~ 0.15 MHz), 4 kHz (0.15 MHz ~ 30 MHz), Scan time: auto.



LINE L RESULTS (UNII-2C BAND LOW CHANNEL, WORST-CASE CONFIGURATION)

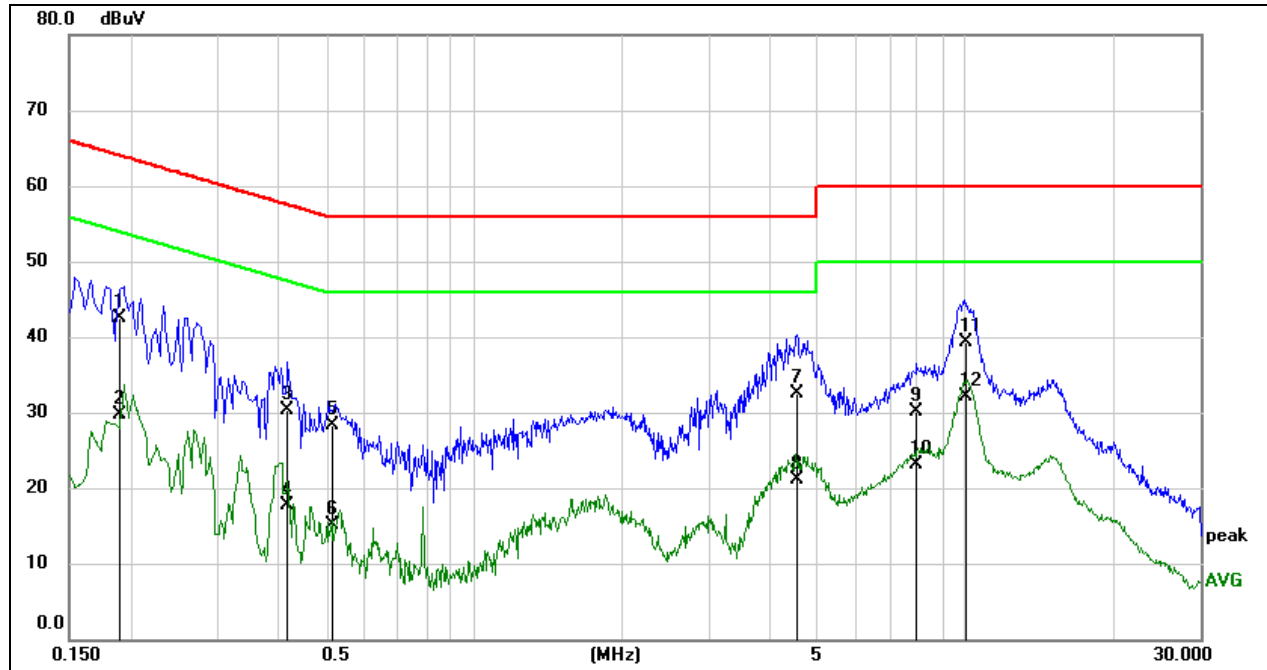

No.	Frequency (MHz)	Reading (dBuV)	Correct (dB)	Result (dBuV)	Limit (dBuV)	Margin (dB)	Remark
1	0.1903	32.96	9.59	42.55	64.02	-21.47	QP
2	0.1903	20.06	9.59	29.65	54.02	-24.37	AVG
3	0.4190	20.65	9.60	30.25	57.47	-27.22	QP
4	0.4190	8.11	9.60	17.71	47.47	-29.76	AVG
5	0.5109	18.74	9.60	28.34	56.00	-27.66	QP
6	0.5109	5.56	9.60	15.16	46.00	-30.84	AVG
7	4.5580	22.94	9.61	32.55	56.00	-23.45	QP
8	4.5580	11.54	9.61	21.15	46.00	-24.85	AVG
9	7.9936	20.53	9.61	30.14	60.00	-29.86	QP
10	7.9936	13.46	9.61	23.07	50.00	-26.93	AVG
11	10.0244	29.67	9.62	39.29	60.00	-20.71	QP
12	10.0244	22.50	9.62	32.12	50.00	-17.88	AVG

- Note: 1. Result = Reading + Correct Factor.
 2. If QP Result complies with AV limit, AV Result is deemed to comply with AV limit.
 3. Test setup: RBW: 200 Hz (9 kHz ~ 150 kHz), 9 kHz (150 kHz ~ 30 MHz).
 4. Step size: 80 Hz (0.009 MHz ~ 0.15 MHz), 4 kHz (0.15 MHz ~ 30 MHz), Scan time: auto.

Note: All the modes, antennas and channels had been tested, but only the worst data was recorded in the report.

10. FREQUENCY STABILITY

LIMITS

The frequency of the carrier signal shall be maintained within band of operation.

TEST PROCEDURE

1. The EUT was placed inside an environmental chamber as the temperature in the chamber was varied between 0 °C ~ 40 °C (declared by customer).
2. The temperature was incremented by 10 °C intervals and the unit allowed to stabilize at each temperature before each measurement. The center frequency of the transmitting channel was evaluated at each temperature and the frequency deviation from the channel's center frequency was recorded.
3. The primary supply voltage is varied from 85 % to 115 % of the nominal value for non hand-carried battery and AC powered equipment. For hand-carried, battery-powered equipment, primary supply voltage is reduced to the battery operating end point which shall be specified by the manufacturer.

Connect the EUT to the spectrum analyser and use the following settings:

Center Frequency	The center frequency of the channel under test
Detector	Peak
RBW	10 kHz
VBW	$\geq 3 \times \text{RBW}$
Span	Encompass the entire emissions bandwidth (EBW) of the signal
Trace	Max hold
Sweep time	Auto

4. While maintaining a constant temperature inside the environmental chamber, turn the EUT on and record the operating frequency at startup, and at 2 minutes, 5minutes, and 10 minutes after the EUT is energized.
5. Allow the trace to stabilize, find the peak value of the power envelope and record the frequency, then calculated the frequency drift.

TEST SETUP

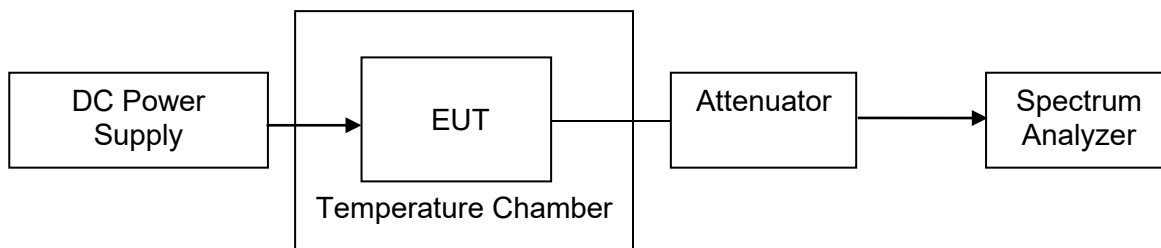



TEST ENVIRONMENT

	Normal Test Conditions	Extreme Test Conditions
Temperature	NT(Normal Temperature): 23.5°C	LT(Low Temperature): 0°C
		HT(High Temperature): 40°C
Supply Voltage	NV(Normal Voltage): DC 5V	LT(Low Voltage): DC 4.5V
		HT(High Voltage): DC 5.5V

Note: The value of the Supply Voltage was declared by customer.

RESULTS

Please refer to Appendix E.

11. DYNAMIC FREQUENCY SELECTION

APPLICABILITY OF DFS REQUIREMENTS

A U-NII network will employ a DFS function to detect signals from radar systems and to avoid co-channel operation with these systems. This applies to the 5250-5350 MHz and/or 5470-5725 MHz bands.

Within the context of the operation of the DFS function, a U-NII device will operate in either Master Mode or Client Mode. U-NII devices operating in Client Mode can only operate in a network controlled by a U-NII device operating in Master Mode.

Table 1: Applicability of DFS Requirements Prior to Use of a Channel

Requirement	Operational Mode		
	<input type="checkbox"/> Master	<input checked="" type="checkbox"/> Client Without Radar Detection	<input type="checkbox"/> Client With Radar Detection
Non-Occupancy Period	Yes	Not required	Yes
DFS Detection Threshold	Yes	Not required	Yes
Channel Availability Check Time	Yes	Not required	Not required
U-NII Detection Bandwidth	Yes	Not required	Yes

Table 2: Applicability of DFS requirements during normal operation

Requirement	Operational Mode	
	<input type="checkbox"/> Master Device or Client with Radar Detection	<input checked="" type="checkbox"/> Client Without Radar Detection
DFS Detection Threshold	Yes	Not required
Channel Closing Transmission Time	Yes	Yes
Channel Move Time	Yes	Yes
U-NII Detection Bandwidth	Yes	Not required

Additional requirements for devices with multiple bandwidth modes	<input type="checkbox"/> Master Device or Client with Radar Detection	<input checked="" type="checkbox"/> Client Without Radar Detection
U-NII Detection Bandwidth and Statistical Performance Check	All BW modes must be tested	Not required
Channel Move Time and Channel Closing Transmission Time	Test using widest BW mode available	Test using the widest BW mode available for the link
All other tests	Any single BW mode	Not required

Note: Frequencies selected for statistical performance check should include several frequencies within the radar detection bandwidth and frequencies near the edge of the radar detection bandwidth. For 802.11 devices it is suggested to select frequencies in each of the bonded 20 MHz channels and the channel center frequency.

LIMITS

(1) DFS Detection Thresholds

Table 3: DFS Detection Thresholds for Master Devices and Client Devices With Radar Detection

Maximum Transmit Power	Value (See Notes 1, 2, and 3)
EIRP \geq 200 milliwatt	-64 dBm
EIRP < 200 milliwatt and power spectral density < 10 dBm/MHz	-62 dBm
EIRP < 200 milliwatt that do not meet the power spectral density requirement	-64 dBm

Note 1: This is the level at the input of the receiver assuming a 0 dBi receive antenna.
 Note 2: Throughout these test procedures an additional 1 dB has been added to the amplitude of the test transmission waveforms to account for variations in measurement equipment. This will ensure that the test signal is at or above the detection threshold level to trigger a DFS response.
 Note3: EIRP is based on the highest antenna gain. For MIMO devices refer to KDB Publication 662911 D01.

(2) DFS Response Requirements

Table 4: DFS Response Requirement Values

Parameter	Value
Non-occupancy period	Minimum 30 minutes
Channel Availability Check Time	60 seconds
Channel Move Time	10 seconds See Note 1.
Channel Closing Transmission Time	200 milliseconds + an aggregate of 60 milliseconds over remaining 10 second period. See Notes 1 and 2.
U-NII Detection Bandwidth	Minimum 100% of the U-NII 99% transmission power bandwidth. See Note 3.

Note 1: Channel Move Time and the Channel Closing Transmission Time should be performed with Radar Type 0. The measurement timing begins at the end of the Radar Type 0 burst.
 Note 2: The Channel Closing Transmission Time is comprised of 200 milliseconds starting at the beginning of the Channel Move Time plus any additional intermittent control signals required facilitating a Channel move (an aggregate of 60 milliseconds) during the remainder of the 10 second period. The aggregate duration of control signals will not count quiet periods in between transmissions.
 Note 3: During the U-NII Detection Bandwidth detection test, radar type 0 should be used. For each frequency step the minimum percentage of detection is 90 percent. Measurements are performed with no data traffic.

PARAMETERS OF RADAR TEST WAVEFORMS

This section provides the parameters for required test waveforms, minimum percentage of successful detections, and the minimum number of trials that must be used for determining DFS conformance. Step intervals of 0.1 microsecond for Pulse Width, 1 microsecond for PRI, 1 MHz for chirp width and 1 for the number of pulses will be utilized for the random determination of specific test waveforms.

Table 5 Short Pulse Radar Test Waveforms

Radar Type	Pulse Width (µsec)	PRI (µsec)	Number of Pulses	Minimum Percentage of Successful Detection	Minimum Number of Trials
0	1	1428	18	See Note 1	See Note 1
1	1	Test A	Roundup $\left\{ \begin{matrix} \frac{1}{360} \\ \frac{19 \cdot 10^9}{PRI_{\mu sec}} \end{matrix} \right\}$	60%	30
		Test B			
2	1-5	150-230	23-29	60%	30
3	6-10	200-500	16-18	60%	30
4	11-20	200-500	12-16	60%	30
Aggregate (Radar Types 1-4)				80%	120
<p>Note 1: Short Pulse Radar Type 0 should be used for the detection bandwidth test, channel move time, and channel closing time tests.</p> <p>Test A: 15 unique PRI values randomly selected from the list of 23 PRI values in Table 5a.</p> <p>Test B: 15 unique PRI values randomly selected within the range of 518-3066 µsec, with a minimum increment of 1 µsec, excluding PRI values selected in Test A.</p>					

A minimum of 30 unique waveforms are required for each of the Short Pulse Radar Types 2 through 4. If more than 30 waveforms are used for Short Pulse Radar Types 2 through 4, then each additional waveform must also be unique and not repeated from the previous waveforms. If more than 30 waveforms are used for Short Pulse Radar Type 1, then each additional waveform is generated with Test B and must also be unique and not repeated from the previous waveforms in Tests A or B. Test aggregate is average of the percentage of successful detections of short pulse radar types 1-4.

TEST SETUP

Setup for Client with injection at the Master

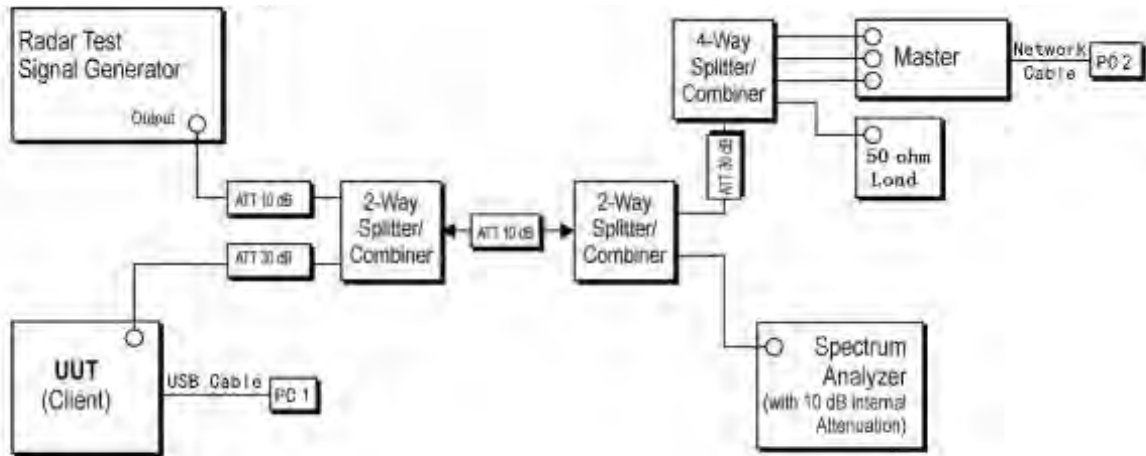

TEST ENVIRONMENT

Temperature	26.8 °C	Relative Humidity	62.3 %
Atmosphere Pressure	101 kPa	Test Voltage	DC 5 V

RESULTS

Please refer to Appendix F.



12. ANTENNA REQUIREMENTS

APPLICABLE REQUIREMENTS

Please refer to FCC §15.203

An intentional radiator shall be designed to ensure that no antenna other than that furnished by the responsible party shall be used with the device. The use of a permanently attached antenna or of an antenna that uses a unique coupling to the intentional radiator shall be considered sufficient to comply with the provisions of this section. The manufacturer may design the unit so that a broken antenna can be replaced by the user, but the use of a standard antenna jack or electrical connector is prohibited.

Please refer to FCC §15.247(b)(4)

The conducted output power limit specified in paragraph (b) of this section is based on the use of antennas with directional gains that do not exceed 6 dBi. Except as shown in paragraph (c) of this section, if transmitting antennas of directional gain greater than 6 dBi are used, the conducted output power from the intentional radiator shall be reduced below the stated values in paragraphs (b)(1), (b)(2), and (b)(3) of this section, as appropriate, by the amount in dB that the directional gain of the antenna exceeds 6 dBi.

RESULTS

Complies



13. Appendix

13.1. Appendix A1: Emission Bandwidth

13.1.1. Test Result

TestMode	Antenna	Channel	26db EBW [MHz]	FL[MHz]	FH[MHz]	Verdict
11A	Ant1	5180	19.880	5170.080	5189.960	PASS
	Ant2	5180	19.840	5170.000	5189.840	PASS
	Ant1	5200	19.760	5190.120	5209.880	PASS
	Ant2	5200	19.640	5190.240	5209.880	PASS
	Ant1	5240	19.880	5230.160	5250.040	PASS
	Ant2	5240	19.400	5230.320	5249.720	PASS
	Ant1	5260	19.840	5250.080	5269.920	PASS
	Ant2	5260	19.760	5250.240	5270.000	PASS
	Ant1	5280	19.960	5270.000	5289.960	PASS
	Ant2	5280	19.840	5270.080	5289.920	PASS
	Ant1	5320	19.840	5310.120	5329.960	PASS
	Ant2	5320	19.840	5310.080	5329.920	PASS
	Ant1	5500	20.160	5489.920	5510.080	PASS
	Ant2	5500	20.080	5490.040	5510.120	PASS
	Ant1	5580	19.960	5569.960	5589.920	PASS
	Ant2	5580	20.160	5569.920	5590.080	PASS
	Ant1	5700	19.960	5690.000	5709.960	PASS
	Ant2	5700	19.960	5690.000	5709.960	PASS
	Ant1	5720	19.960	5709.920	5729.880	PASS
	Ant2	5720	19.960	5710.120	5730.080	PASS
	Ant1	5720 UNII-2C	15.08	5709.920	5725	PASS
	Ant2	5720 UNII-2C	14.88	5710.120	5725	PASS
	Ant1	5720 UNII-3	4.88	5725	5729.880	PASS
	Ant2	5720 UNII-3	5.08	5725	5730.080	PASS
	Ant1	5745	20.160	5734.960	5755.120	PASS
	Ant2	5745	19.920	5735.040	5754.960	PASS
	Ant1	5785	19.880	5775.120	5795.000	PASS
	Ant2	5785	20.080	5775.000	5795.080	PASS
	Ant1	5825	20.280	5814.880	5835.160	PASS
	Ant2	5825	20.000	5814.880	5834.880	PASS
11N20MIMO	Ant1	5180	20.400	5169.800	5190.200	PASS
	Ant2	5180	20.200	5169.880	5190.080	PASS
	Ant1	5200	20.240	5189.880	5210.120	PASS
	Ant2	5200	20.160	5189.960	5210.120	PASS
	Ant1	5240	20.120	5229.960	5250.080	PASS
	Ant2	5240	20.200	5229.840	5250.040	PASS
	Ant1	5260	20.040	5249.920	5269.960	PASS
	Ant2	5260	19.960	5250.000	5269.960	PASS
	Ant1	5280	20.240	5269.760	5290.000	PASS
	Ant2	5280	20.000	5269.960	5289.960	PASS
	Ant1	5320	20.160	5309.920	5330.080	PASS
	Ant2	5320	20.320	5309.840	5330.160	PASS
	Ant1	5500	20.280	5489.840	5510.120	PASS
	Ant2	5500	20.320	5489.840	5510.160	PASS
	Ant1	5580	20.240	5569.800	5590.040	PASS
	Ant2	5580	20.240	5569.840	5590.080	PASS
	Ant1	5700	20.240	5689.920	5710.160	PASS
	Ant2	5700	20.280	5689.800	5710.080	PASS
	Ant1	5720	20.120	5709.920	5730.040	PASS
	Ant2	5720	20.240	5709.880	5730.120	PASS
	Ant1	5720 UNII-2C	15.08	5709.920	5725	PASS
	Ant2	5720 UNII-2C	15.12	5709.880	5725	PASS



	Ant1	5720 UNII-3	5.04	5725	5730.040	PASS
	Ant2	5720 UNII-3	5.12	5725	5730.120	PASS
	Ant1	5745	20.120	5734.960	5755.080	PASS
	Ant2	5745	20.040	5734.920	5754.960	PASS
	Ant1	5785	20.520	5774.720	5795.240	PASS
	Ant2	5785	20.360	5774.800	5795.160	PASS
	Ant1	5825	20.040	5815.040	5835.080	PASS
	Ant2	5825	20.160	5814.880	5835.040	PASS
11N40MIMO	Ant1	5190	40.560	5169.760	5210.320	PASS
	Ant2	5190	39.680	5170.160	5209.840	PASS
	Ant1	5230	40.320	5209.920	5250.240	PASS
	Ant2	5230	40.160	5209.840	5250.000	PASS
	Ant1	5270	41.280	5249.120	5290.400	PASS
	Ant2	5270	40.240	5249.920	5290.160	PASS
	Ant1	5310	40.320	5289.680	5330.000	PASS
	Ant2	5310	39.920	5289.920	5329.840	PASS
	Ant1	5510	40.720	5489.600	5530.320	PASS
	Ant2	5510	39.920	5490.080	5530.000	PASS
	Ant1	5550	40.000	5530.000	5570.000	PASS
	Ant2	5550	40.160	5530.160	5570.320	PASS
	Ant1	5670	40.640	5649.760	5690.400	PASS
	Ant2	5670	39.840	5649.840	5689.680	PASS
	Ant1	5710	40.800	5689.360	5730.160	PASS
	Ant2	5710	39.920	5689.840	5729.760	PASS
	Ant1	5710 UNII-2C	35.64	5689.360	5725	PASS
	Ant2	5710 UNII-2C	35.16	5689.840	5725	PASS
	Ant1	5710 UNII-3	5.16	5725	5730.160	PASS
	Ant2	5710 UNII-3	4.76	5725	5729.760	PASS
11AC20MIMO	Ant1	5755	40.800	5734.440	5775.240	PASS
	Ant2	5755	40.400	5734.920	5775.320	PASS
	Ant1	5795	40.320	5774.840	5815.160	PASS
	Ant2	5795	40.160	5774.920	5815.080	PASS
	Ant1	5180	20.160	5169.920	5190.080	PASS
	Ant2	5180	20.120	5169.880	5190.000	PASS
	Ant1	5200	20.160	5190.000	5210.160	PASS
	Ant2	5200	20.040	5189.920	5209.960	PASS
	Ant1	5240	20.400	5229.640	5250.040	PASS
	Ant2	5240	19.920	5230.000	5249.920	PASS
	Ant1	5260	20.360	5249.800	5270.160	PASS
	Ant2	5260	20.160	5249.960	5270.120	PASS
	Ant1	5280	20.120	5269.880	5290.000	PASS
	Ant2	5280	19.920	5270.080	5290.000	PASS
	Ant1	5320	20.280	5309.920	5330.200	PASS
	Ant2	5320	20.200	5309.880	5330.080	PASS
	Ant1	5500	20.200	5489.960	5510.160	PASS
	Ant2	5500	20.240	5489.880	5510.120	PASS
	Ant1	5580	20.080	5569.920	5590.000	PASS
	Ant2	5580	19.960	5570.000	5589.960	PASS
Ant1	5700	20.320	5689.920	5710.240	PASS	
Ant2	5700	20.080	5689.920	5710.000	PASS	
Ant1	5720	20.120	5709.920	5730.040	PASS	
Ant2	5720	20.080	5710.000	5730.080	PASS	
Ant1	5720 UNII-2C	15.08	5709.920	5725	PASS	
Ant2	5720 UNII-2C	15	5710.000	5725	PASS	
Ant1	5720 UNII-3	5.04	5725	5730.040	PASS	
Ant2	5720 UNII-3	5.08	5725	5730.080	PASS	
Ant1	5745	20.120	5734.960	5755.080	PASS	
Ant2	5745	20.040	5735.080	5755.120	PASS	
Ant1	5785	20.200	5774.800	5795.000	PASS	
Ant2	5785	20.480	5774.800	5795.280	PASS	