



**CFR 47 FCC PART 15 SUBPART E
ISED RSS-247 ISSUE 2**

TEST REPORT

For

IEEE 802.11a/b/g/n/ac 2T2R USB WiFi Module

MODEL NUMBER: SKO.W7612U.2

**FCC ID: 2AR82-SKOW7612U21
IC: 24728-SKOW7612U21**

REPORT NUMBER: 4788955528-1

ISSUE DATE: April 28, 2019

Prepared for

**Guangzhou Shikun Electronics Co., Ltd
NO.192 KEZHU ROAD, SCIENCE PARK GUANGZHOU, GUANGDONG, CHINA**

Prepared by

**UL Verification Services (Guangzhou) Co., Ltd, Song Shan Lake Branch
Building 10, Innovation Technology Park, No. 1, Li Bin Road, Song Shan Lake
Hi-Tech Development Zone Dongguan, People's Republic of China**

Tel: +86 769 22038881

Fax: +86 769 33244054

Website: www.ul.com



Revision History

<u>Rev.</u>	<u>Issue Date</u>	<u>Revisions</u>	<u>Revised By</u>
V0	4/28/2019	Initial Issue	
V1	5/17/2019	Revised report to address TCB's questions	Kebo Zhang



Summary of Test Results			
Clause	Test Items	FCC/IC Rules	Test Results
1	6/26db Bandwidth	FCC 15.407 (a)&(e) RSS-247 Clause 6.2	PASS
2	99% Bandwidth	RSS-Gen Clause 6.6	PASS
3	Maximum Conducted Output Power	FCC 15.407 (a) RSS-247 Clause 6.2	PASS
4	Power Spectral Density	FCC 15.407 (a) RSS-247 Clause 6.2	PASS
5	Antenna Conducted Spurious Emission	FCC 15.407 (b) RSS-247 Clause 6.2	PASS
6	Radiated Bandedge and Spurious Emission	FCC 15.407 (a) FCC 15.209 FCC 15.205 RSS-247 Clause 6.2 RSS-GEN Clause 8.9	PASS
7	Conducted Emission Test For AC Power Port	FCC 15.207 RSS-GEN Clause 8.8	PASS
8	Antenna Requirement	FCC 15.203 RSS-GEN Clause 8.3	PASS
9	Frequency Stability	FCC 15.407 (g)	PASS
10	Dynamic Frequency Selection	FCC 15.407 (h)	PASS



TABLE OF CONTENTS

1. ATTESTATION OF TEST RESULTS	6
2. TEST METHODOLOGY	7
3. FACILITIES AND ACCREDITATION	7
4. CALIBRATION AND UNCERTAINTY	8
4.1. <i>MEASURING INSTRUMENT CALIBRATION</i>	<i>8</i>
4.2. <i>MEASUREMENT UNCERTAINTY.....</i>	<i>8</i>
5. EQUIPMENT UNDER TEST	9
5.1. <i>DESCRIPTION OF EUT</i>	<i>9</i>
5.2. <i>MAXIMUM EIRP</i>	<i>10</i>
5.3. <i>CHANNEL LIST.....</i>	<i>11</i>
5.4. <i>THE WORSE CASE POWER SETTING PARAMETER.....</i>	<i>12</i>
5.5. <i>THE WORSE CASE CONFIGURATIONS</i>	<i>12</i>
5.6. <i>DESCRIPTION OF AVAILABLE ANTENNAS</i>	<i>13</i>
5.7. <i>DESCRIPTION OF TEST SETUP.....</i>	<i>14</i>
6. MEASURING INSTRUMENT AND SOFTWARE USED	15
7. ANTENNA PORT TEST RESULTS	17
7.1. <i>ON TIME AND DUTY CYCLE.....</i>	<i>17</i>
7.2. <i>6/26/99% dB BANDWIDTH.....</i>	<i>19</i>
7.2.1. <i>802.11a SISO MODE.....</i>	<i>21</i>
7.2.2. <i>802.11n HT20 MIMO MODE.....</i>	<i>26</i>
7.2.3. <i>802.11n HT40 MIMO MODE.....</i>	<i>31</i>
7.2.4. <i>802.11ac VHT80 MIMO MODE.....</i>	<i>36</i>
7.3. <i>MAXIMUM CONDUCTED OUTPUT POWER.....</i>	<i>40</i>
7.3.1. <i>UNII-1 BAND</i>	<i>41</i>
7.3.2. <i>UNII-2A BAND</i>	<i>42</i>
7.3.3. <i>UNII-2C BAND.....</i>	<i>43</i>
7.3.4. <i>STRADDLE CHANNEL.....</i>	<i>45</i>
7.3.5. <i>UNII-3 BAND</i>	<i>51</i>
7.4. <i>POWER SPECTRAL DENSITY.....</i>	<i>52</i>
7.4.1. <i>802.11a SISO MODE.....</i>	<i>54</i>
7.4.2. <i>802.11n HT20 CDD MODE.....</i>	<i>62</i>
7.4.3. <i>802.11n HT40 CDD MODE.....</i>	<i>70</i>
7.4.4. <i>802.11ac VHT80 CDD MODE.....</i>	<i>76</i>
8. RADIATED TEST RESULTS.....	81
8.1. <i>802.11a SISO MODE.....</i>	<i>87</i>
8.1.1. <i>UNII-1 BAND</i>	<i>87</i>



8.1.2.	UNII-2A BAND	103
8.1.3.	UNII-2C BAND.....	119
8.1.4.	STRADDLE CHANNEL 144	137
8.1.5.	UNII-3 BAND	141
8.2.	<i>802.11n HT20 MIMO MODE</i>	157
8.2.1.	UNII-1 BAND	157
8.2.2.	UNII-2A BAND	173
8.2.3.	UNII-2C BAND.....	189
8.2.4.	STRADDLE CHANNEL 144	207
8.2.5.	UNII-3 BAND	211
8.3.	<i>802.11n HT40 MIMO MODE</i>	227
8.3.1.	UNII-1 BAND	227
8.3.2.	UNII-2A BAND	239
8.3.3.	UNII-2C BAND.....	251
8.3.1.	STRADDLE CHANNEL 142.....	269
8.3.2.	UNII-3 BAND	273
8.4.	<i>802.11ac VHT80 MIMO MODE</i>	285
8.4.1.	UNII-1 BAND	285
8.4.2.	UNII-2A BAND	293
8.4.3.	UNII-2C BAND.....	301
8.4.4.	STRADDLE CHANNEL 138.....	315
8.4.5.	UNII-3 BAND	319
8.5.	<i>SPURIOUS EMISSIONS 18~26GHz</i>	325
8.5.1.	802.11HT20 MIMO MODE.....	325
8.6.	<i>SPURIOUS EMISSIONS 26~40GHz</i>	327
8.6.1.	802.11HT20 MIMO MODE.....	327
8.7.	<i>SPURIOUS EMISSIONS 30M ~ 1 GHz</i>	329
8.7.1.	802.11HT20 MIMO MODE.....	329
8.8.	<i>SPURIOUS EMISSIONS BELOW 30M</i>	331
8.8.1.	802.11HT20 MIMO MODE.....	331
9.	AC POWER LINE CONDUCTED EMISSIONS	337
9.1.	<i>802.11nHT20 MIMO MODE</i>	338
10.	FREQUENCY STABILITY.....	340
11.	DYNAMIC FREQUENCY SELECTION	342
12.	ANTENNA REQUIREMENTS	347



1. ATTESTATION OF TEST RESULTS

Applicant Information

Company Name: Guangzhou Shikun Electronics Co., Ltd
Address: NO.192 KEZHU ROAD,SCIENCE PARK
GUANGZHOU,GUANGDONG,CHINA

Manufacturer Information

Company Name: Guangzhou Shikun Electronics Co., Ltd
Address: NO.192 KEZHU ROAD,SCIENCE PARK
GUANGZHOU,GUANGDONG,CHINA

EUT Description

EUT Name: IEEE 802.11a/b/g/n/ac 2T2R USB WiFi Module
Model: SKO.W7612U.2
Sample Status: Normal
Sample Received Date: April 21, 2019
Date of Tested: April 22~ 28, 2019

APPLICABLE STANDARDS	
STANDARD	TEST RESULTS
CFR 47 FCC PART 15 SUBPART E	PASS
ISED RSS-247 Issue 2	PASS
ISED RSS-GEN Issue 5	PASS

Prepared By:

Checked By:

Kebo Zhang
Engineer Project Associate
Approved By:

Shawn Wen
Laboratory Leader

Stephen Guo
Laboratory Manager



2. TEST METHODOLOGY

The tests documented in this report were performed in accordance with ANSI C63.10-2013, CFR 47 FCC Part 2, CFR 47 FCC Part 15, KDB 789033 D02 v02r01, RSS-GEN Issue 5, RSS-247 Issue 2, KDB414788 D01 Radiated Test Site v01r01, KDB 905462 D02 UNII DFS Compliance Procedures New Rules v02 and 905462 D03 Client Without DFS New Rules v01r02.

3. FACILITIES AND ACCREDITATION

Accreditation Certificate	<p>A2LA (Certificate No.: 4102.01) UL Verification Services (Guangzhou) Co., Ltd. Song Shan Lake Branch. has been assessed and proved to be in compliance with A2LA.</p> <p>FCC (FCC Designation No.: CN1187) UL Verification Services (Guangzhou) Co., Ltd. Song Shan Lake Branch. Has been recognized to perform compliance testing on equipment subject to the Commission's Declaration of Conformity (DoC) and Certification rules</p> <p>IC(Company No.: 21320) UL Verification Services (Guangzhou) Co., Ltd. Song Shan Lake Branch. has been registered and fully described in a report filed with ISED. The Company Number is 21320.</p> <p>VCCI (Registration No.: G-20019, R-20004, C-20012 and T-20011) UL Verification Services (Guangzhou) Co., Ltd. Song Shan Lake Branch. has been assessed and proved to be in compliance with VCCI, the Membership No. is 3793. Facility Name: Chamber D, the VCCI registration No. is G-20019 and R-20004 Shielding Room B , the VCCI registration No. is C-20012 and T-20011</p>
---------------------------	---

Note 1: All tests measurement facilities use to collect the measurement data are located at Building 10, Innovation Technology Park, Song Shan Lake Hi tech Development Zone, Dongguan, 523808, China

Note 2: The test anechoic chamber in UL Verification Services (Guangzhou) Co., Ltd. Song Shan Lake Branch had been calibrated and compared to the open field sites and the test anechoic chamber is shown to be equivalent to or worst case from the open field site.

Note 3: For below 30MHz, lab had performed measurements at test anechoic chamber and comparing to measurements obtained on an open field site. And these measurements below 30MHz had been correlated to measurements performed on an OFS.



4. CALIBRATION AND UNCERTAINTY

4.1. MEASURING INSTRUMENT CALIBRATION

The measuring equipment utilized to perform the tests documented in this report has been calibrated in accordance with the manufacturer's recommendations, and is traceable to recognize national standards.

4.2. MEASUREMENT UNCERTAINTY

Where relevant, the following measurement uncertainty levels have been estimated for tests performed on the apparatus:

Test Item	Uncertainty
Uncertainty for Conduction emission test	3.62dB
Uncertainty for Radiation Emission test(include Fundamental emission) (9KHz-30MHz)	2.2dB
Uncertainty for Radiation Emission test(include Fundamental emission) (30MHz-1GHz)	4.00dB
Uncertainty for Radiation Emission test (1GHz to 26GHz)(include Fundamental emission)	5.78dB (1GHz-18Gz)
	5.23dB (18GHz-26Gz)
	5.64dB (26GHz-40Gz)
Note: This uncertainty represents an expanded uncertainty expressed at approximately the 95% confidence level using a coverage factor of k=2.	



5. EQUIPMENT UNDER TEST

5.1. DESCRIPTION OF EUT

EUT Name	IEEE 802.11a/b/g/n/ac 2T2R USB WiFi Module
Model	SKO.W7612U.2
Radio Technology	IEEE802.11a IEEE802.11n HT20/HT40 IEEE802.11ac HT20/HT40/HT80
Operation frequency	UNII-1/UNII-2A/UNII-2C/UNII-3
Modulation	OFDM(BPSK,QPSK,16QAM,64QAM,256QAM in ac mode only.)
Rated Input	DC 5V

5.2. MAXIMUM EIRP

UNII-1 BAND

IEE Std. 802.11	Frequency (MHz)	Max Power (dBm)	Max EIRP (dBm)
a SISO	5150-5250	14.73	16.30
n(HT20) MIMO	5150-5250	16.11	17.77
n(HT40) MIMO	5150-5250	16.31	17.79
ac(HT20) MIMO	5150-5250	16.16	17.82
ac(HT40) MIMO	5150-5250	16.07	17.73
ac(HT80) MIMO	5150-5250	15.57	17.23

UNII-2A BAND

IEE Std. 802.11	Frequency (MHz)	Max Power (dBm)
a SISO	5250-5350	14.85
n(HT20) MIMO	5250-5350	16.74
n(HT40) MIMO	5250-5350	16.59
ac(HT20) MIMO	5250-5350	16.74
ac(HT40) MIMO	5250-5350	16.42
ac(HT80) MIMO	5250-5350	15.50

UNII-2C BAND

IEE Std. 802.11	Frequency (MHz)	Max Power (dBm)
a SISO	5470-5725	14.95
n(HT20) MIMO	5470-5725	16.89
n(HT40) MIMO	5470-5725	16.91
ac(HT20) MIMO	5470-5725	16.88
ac(HT40) MIMO	5470-5725	16.95
ac(HT80) MIMO	5470-5725	15.85

UNII-3 BAND

IEE Std. 802.11	Frequency (MHz)	Max Power (dBm)
a SISO	5725-5850	14.87
n(HT20) MIMO	5725-5850	16.46
n(HT40) MIMO	5725-5850	16.41
ac(HT20) MIMO	5725-5850	16.84
ac(HT40) MIMO	5725-5850	16.70
ac(HT80) MIMO	5725-5850	15.78



5.3. CHANNEL LIST

UNII-1 (For Bandwidth=20MHz)		UNII-1 (For Bandwidth=40MHz)		UNII-1 (For Bandwidth=80MHz)	
Channel	Frequency (MHz)	Channel	Frequency (MHz)	Channel	Frequency (MHz)
36	5180	38	5190	42	5210
40	5200	46	5230		
44	5220				
48	5240				

UNII-2A (For Bandwidth=20MHz)		UNII-2A (For Bandwidth=40MHz)		UNII-2A (For Bandwidth=80MHz)	
Channel	Frequency (MHz)	Channel	Frequency (MHz)	Channel	Frequency (MHz)
52	5260	54	5270	58	5290
56	5280	62	5310		
60	5300				
64	5320				

UNII-2C (For Bandwidth=20MHz)		UNII-2C (For Bandwidth=40MHz)		UNII-2C (For Bandwidth=80MHz)	
Channel	Frequency (MHz)	Channel	Frequency (MHz)	Channel	Frequency (MHz)
100	5500	102	5510	106	5530
104	5520	110	5550	122	5610
108	5540	118	5590	138	5690
112	5560	126	5630		
116	5580	134	5670		
120	5600	142	5710		
124	5620				
128	5640				
132	5660				
136	5680				
140	5700				
144	5720				

UNII-3		UNII-3		UNII-3	
Channel	Frequency (MHz)	Channel	Frequency (MHz)	Channel	Frequency (MHz)
149	5745	151	5755	155	5775
153	5765	159	5795		
157	5785				
161	5805				
165	5825				



5.4. THE WORSE CASE POWER SETTING PARAMETER

The Worse Case Power Setting Parameter	
Test Software	MT7662 QAV1.0.2.8
Frequency Band	Setting
UNII-1	default
UNII-2A	default
UNII-2C	default
UNII-3	default

5.5. THE WORSE CASE CONFIGURATIONS

For SISO modes, there are two transmission antennas. The antenna used in any given time can be either ANTENNA 1 or ANTENNA 2. All antenna ports have the same power; output power measurement for SISO modes on both antennas are reported.

For 2TX MIMO modes, ANTENNA 1 and ANTENNA 2, used at the same time.

Worst-case data rates as provided by the client were:

802.11a mode: 6 Mbps

802.11n HT20 mode: MCS0

802.11n HT40 mode: MCS0

802.11ac VHT20 mode: MCS0

802.11ac VHT40 mode: MCS0

802.11ac VHT80 mode: MCS0

802.11ac VHT20 and VHT40 mode are different from 802.11nHT20 and HT40 only in control messages and have the same power settings, so for these 4 modes, only 802.11nHT20 and 802.11nHT40 modes data are recorded in the report .

802.11a support SISO mode, two antenna have the same power setting, so only the worst data for antenna 2 are recorded in the report.



5.6. DESCRIPTION OF AVAILABLE ANTENNAS

Antenna No.	Frequency (MHz)	Antenna Type	Max Antenna Gain (dBi)
1	5150-5850	PCB Antenna	1.49
2	5150-5850		1.66

Note: Directional gain= $10\log[(10^{G1/20} + 10^{G2/20})^2 / N_{ANT}] = 4.59 < 6\text{dBi}$
 N_{ANT} : the number of Antenna

IEE Std. 802.11	Transmit and Receive Mode	Description
802.11a	<input checked="" type="checkbox"/> 2TX, 2RX	ANT 1, 2 can be used as transmitting/receiving antenna.
802.11n HT20	<input checked="" type="checkbox"/> 2TX, 2RX	ANT 1, 2 can be used as transmitting/receiving antenna.
802.11n HT40	<input checked="" type="checkbox"/> 2TX, 2RX	ANT 1, 2 can be used as transmitting/receiving antenna.
802.11ac VHT20	<input checked="" type="checkbox"/> 2TX, 2RX	ANT 1, 2 can be used as transmitting/receiving antenna.
802.11ac VHT40	<input checked="" type="checkbox"/> 2TX, 2RX	ANT 1, 2 can be used as transmitting/receiving antenna.
802.11ac VHT80	<input checked="" type="checkbox"/> 2TX, 2RX	ANT 1, 2 can be used as transmitting/receiving antenna.

Note:

1. Only 802.11a support SISO mode
2. WLAN 2.4G & WLAN 5G can't transmit simultaneously. (declared by client)

5.7. DESCRIPTION OF TEST SETUP

SUPPORT EQUIPMENT

Item	Equipment	Brand Name	Model Name	P/N
1	PC	Dell	Vostro 3902	8KNDDDB2
2	Debug	N/A	N/A	N/A

I/O CABLES

Cable No	Port	Connector Type	Cable Type	Cable Length(m)	Remarks
1	PCIEX	N/A	N/A	0.1	N/A
2	USB	N/A	N/A	0.5	N/A

ACCESSORIES

Item	Accessory	Brand Name	Model Name	Description
1	Power Adapter	N/A	HW-120150E2W	INPUT:100-240V~50/60Hz, 0.5A OUTPUT:12.0V, 1.5A

TEST SETUP

The EUT can work in engineering mode with a software through a Laptop.

SETUP DIAGRAM FOR TESTS

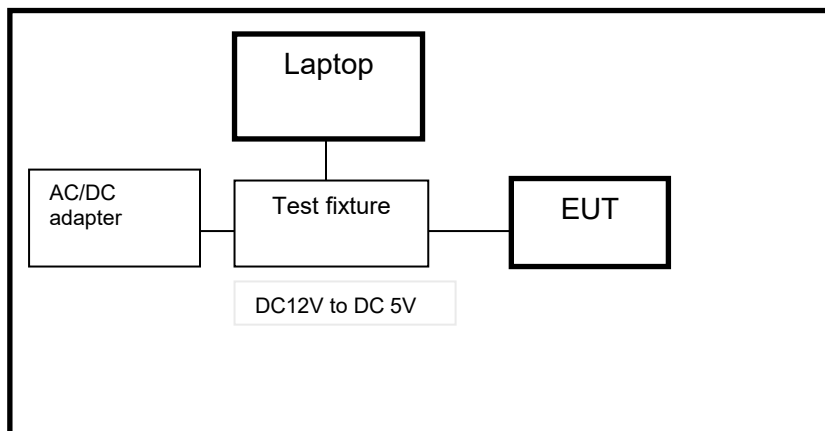



6. MEASURING INSTRUMENT AND SOFTWARE USED

Conducted Emissions						
Instrument						
Used	Equipment	Manufacturer	Model No.	Serial No.	Last Cal.	Next Cal.
<input checked="" type="checkbox"/>	EMI Test Receiver	R&S	ESR3	101961	Dec.10,2018	Dec.10,2019
<input checked="" type="checkbox"/>	Two-Line V-Network	R&S	ENV216	101983	Dec.10,2018	Dec.10,2019
<input checked="" type="checkbox"/>	Artificial Mains Networks	Schwarzbeck	NSLK 8126	8126465	Dec.10,2018	Dec.10,2019
Software						
Used	Description	Manufacturer	Name	Version		
<input checked="" type="checkbox"/>	Test Software for Conducted disturbance	Farad	EZ-EMC	Ver. UL-3A1		
Radiated Emissions						
Instrument						
Used	Equipment	Manufacturer	Model No.	Serial No.	Last Cal.	Next Cal.
<input checked="" type="checkbox"/>	MXE EMI Receiver	KESIGHT	N9038A	MY56400036	Dec.10,2018	Dec.10,2019
<input checked="" type="checkbox"/>	Hybrid Log Periodic Antenna	TDK	HLP-3003C	130960	Sep.17, 2018	Sep.17, 2021
<input checked="" type="checkbox"/>	Preamplifier	HP	8447D	2944A09099	Dec.10,2018	Dec.10,2019
<input checked="" type="checkbox"/>	EMI Measurement Receiver	R&S	ESR26	101377	Dec.10,2018	Dec.10,2019
<input checked="" type="checkbox"/>	Horn Antenna	TDK	HRN-0118	130939	Sep.17, 2018	Sep.17, 2021
<input checked="" type="checkbox"/>	High Gain Horn Antenna	Schwarzbeck	BBHA-9170	691	Aug.11, 2018	Aug.11, 2021
<input checked="" type="checkbox"/>	Preamplifier	TDK	PA-02-0118	TRS-305-00066	Dec.10,2018	Dec.10,2019
<input checked="" type="checkbox"/>	Preamplifier	TDK	PA-02-2	TRS-307-00003	Dec.10,2018	Dec.10,2019
<input checked="" type="checkbox"/>	Loop antenna	Schwarzbeck	1519B	00008	Mar.26,2016	Mar.25, 2019
<input checked="" type="checkbox"/>	Band Reject Filter	Wainwright	WRCJV8-2350-2400-2483.5-2533.5-40SS	4	Dec.10,2018	Dec.10,2019
<input checked="" type="checkbox"/>	High Pass Filter	Wi	WHKX10-2700-3000-18000-40SS	23	Dec.10,2018	Dec.10,2019
Software						
Used	Description	Manufacturer	Name	Version		
<input checked="" type="checkbox"/>	Test Software for Radiated disturbance	Farad	EZ-EMC	Ver. UL-3A1		



Other instruments						
Used	Equipment	Manufacturer	Model No.	Serial No.	Last Cal.	Next Cal.
<input checked="" type="checkbox"/>	Spectrum Analyzer	Keysight	N9030A	MY55410512	Dec.10,2018	Dec.10,2019
<input checked="" type="checkbox"/>	Power Meter	Keysight	N1911A	MY55416024	Dec.10,2018	Dec.10,2019
<input checked="" type="checkbox"/>	Power Sensor	Keysight	U2021XA	MY5100022	Dec.10,2018	Dec.10,2019
<input checked="" type="checkbox"/>	Power sensor, Power Meter	R&S	OSP- B157W8/X	100921	Dec.10,2018	Dec.10,2019



7. ANTENNA PORT TEST RESULTS

7.1. ON TIME AND DUTY CYCLE

LIMITS

None; for reporting purposes only

TEST SETUP

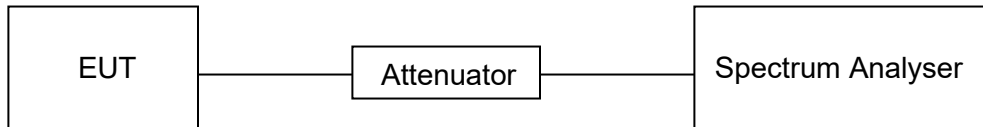

TEST ENVIRONMENT

Temperature	24.6°C	Relative Humidity	56%
Atmosphere Pressure	101kPa	Test Voltage	DC 5V

RESULTS

Mode	ON Time (ms)	Period (ms)	Duty Cycle x (Linear)	Duty Cycle (%)	Duty Cycle Correction Factor (dB)	1/B Minimum VBW (KHz)
11a 1TX	122.1	122.1	1	100%	0	0.01
11n HT20 MIMO	122.2	122.3	1	100%	0	0.01
11n HT40 MIMO	124.0	123.9	1	100%	0	0.01
11ac HT80 MIMO	122.6	122.5	1	100%	0	0.01

Note:

Duty Cycle Correction Factor=10log (1/x).

Where: x is Duty Cycle (Linear)

Where: T is On Time

If that calculated VBW is not available on the analyzer then the next higher value should be used.

Antenna 1 and Antenna 2 has the same duty cycle, only ANT 1 data show here.



802.11a



802.11n HT20



802.11n HT40



802.11ac HT80

7.2. 6/26/99% dB BANDWIDTH

LIMITS

CFR 47 FCC Part15, Subpart E ISED RSS-247		
Test Item	Limit	Frequency Range (MHz)
Bandwidth	26 dB Bandwidth	5150-5250
	26 dB Bandwidth	5250-5350
	26 dB Bandwidth	For FCC:5470-5725 For IC:5470-5600 5650-5725
	Minimum 500kHz 6dB Bandwidth	5725-5850

ISED RSS-247		
RSS-Gen Clause 6.6	99% Bandwidth	For reporting purposes only.

TEST PROCEDURE

Connect the UUT to the spectrum analyser and use the following settings:

Center Frequency	The center frequency of the channel under test
Detector	Peak
RBW	For 6dB Bandwidth: RBW=100kHz For 26dB Bandwidth: approximately 1% of the emission bandwidth. For 99dB Bandwidth: approximately 1%~5% of the emission bandwidth.
VBW	For 6dB Bandwidth : VBW=300kHz For 26dB Bandwidth : >3RBW For 99%dB Bandwidth : >3RBW
Trace	Max hold
Sweep	Auto couple

Allow the trace to stabilize and measure the maximum width of the emission that is constrained by the frequencies associated with the two outermost amplitude points (upper and lower frequencies) that are attenuated by 6dB/26dB&99% Occupied Bandwidth relative to the maximum level measured in the fundamental emission.

TEST SETUP

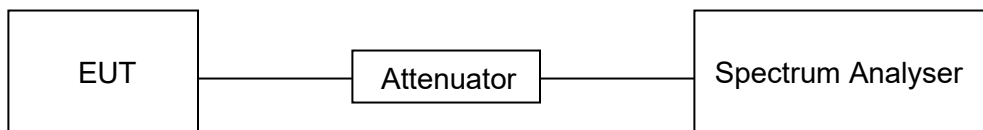



TEST ENVIRONMENT

Temperature	24.6°C	Relative Humidity	56%
Atmosphere Pressure	101kPa	Test Voltage	DC 5V

RESULTS



7.2.1. 802.11a SISO MODE

ANT2 WORST CASE

UNII-1 BAND

Channel	Frequency (MHz)	26 dB BW (MHz)	99% BW (MHz)
Low	5180	20.02	16.668
Mid	5200	19.79	16.694
High	5240	19.81	16.615

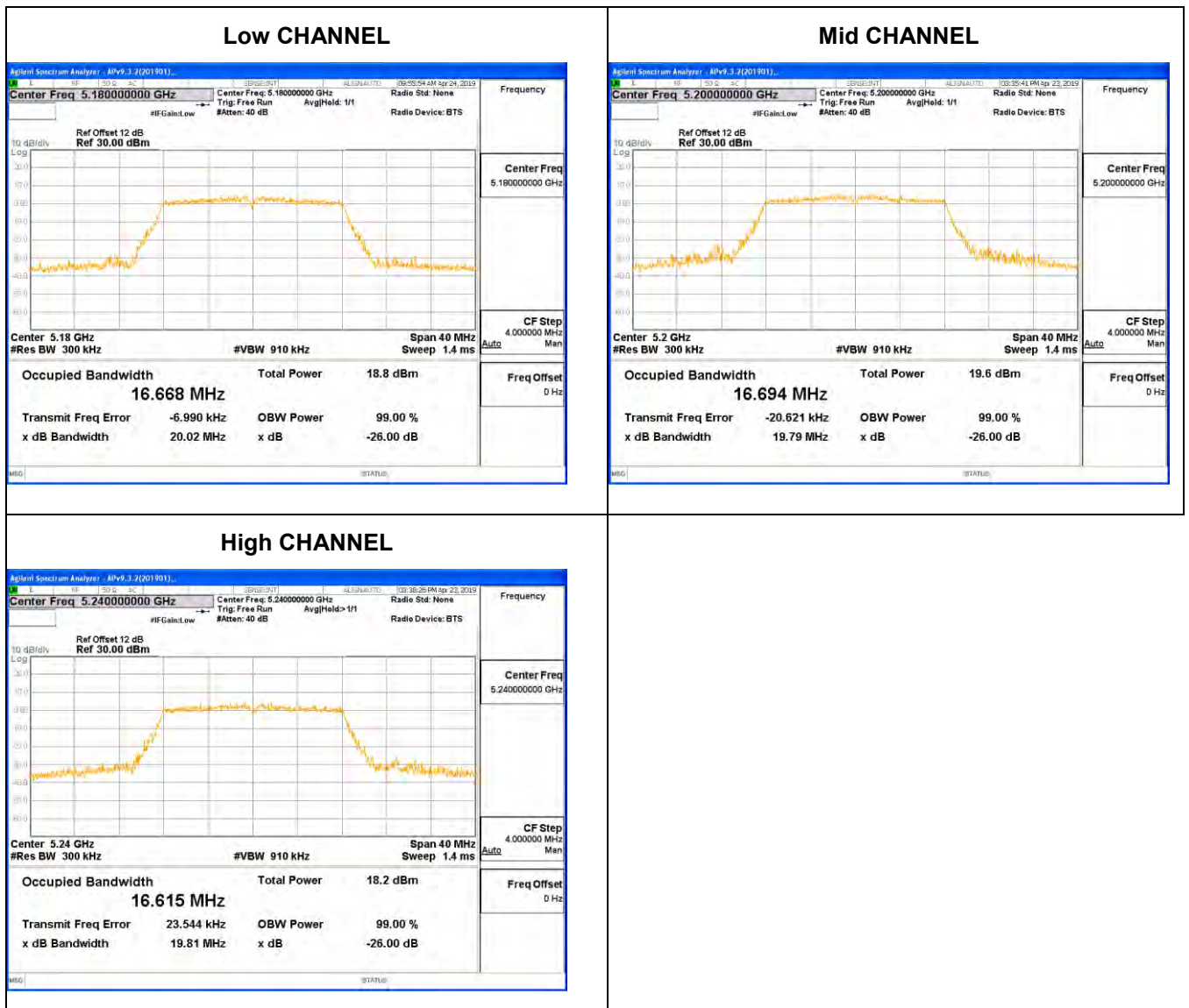



UNII-2A BAND

Channel	Frequency (MHz)	26 dB BW (MHz)	99% BW (MHz)
Low	5260	20.30	16.779
Mid	5300	21.38	16.792
High	5320	21.82	16.750

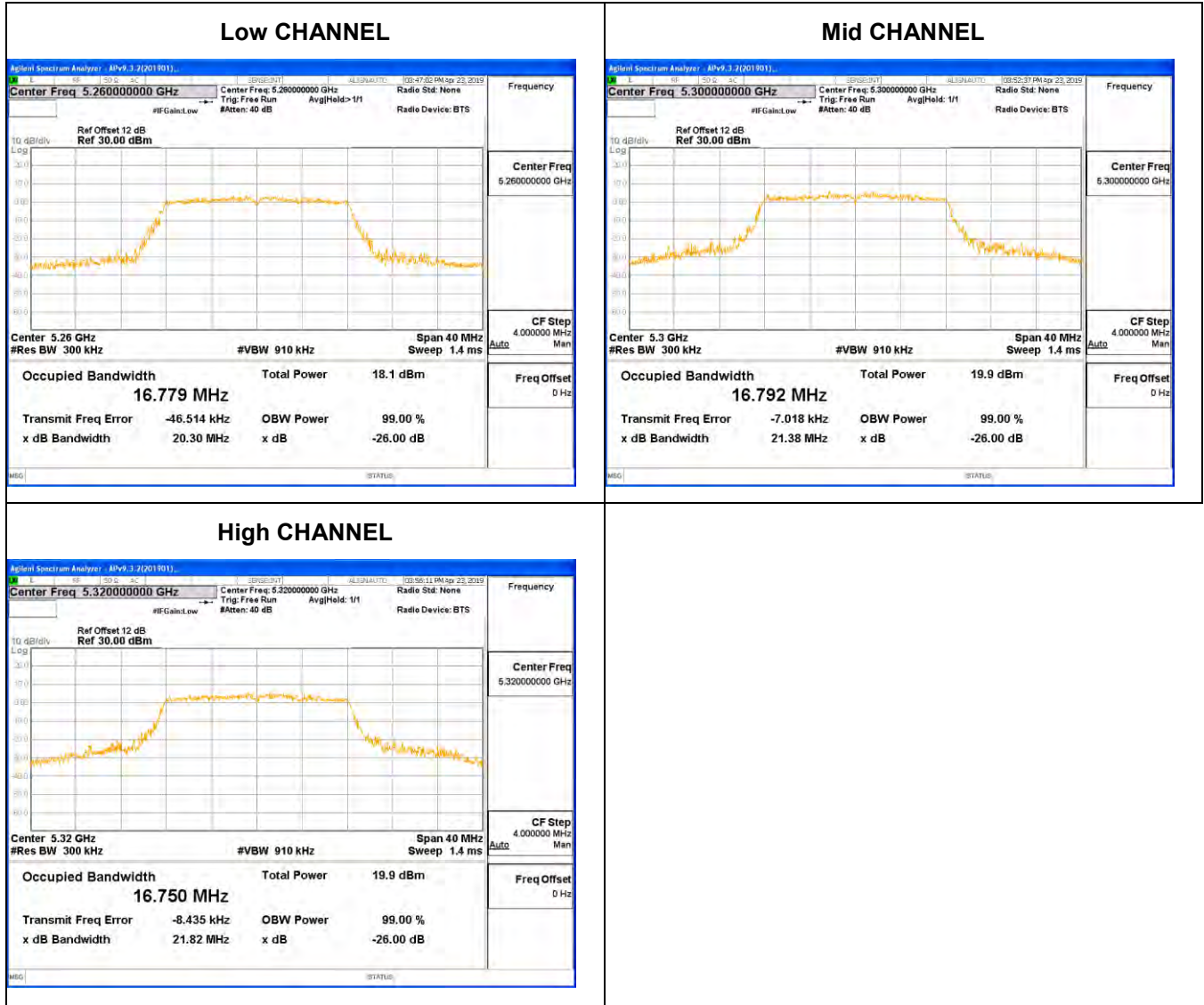



UNII-2C BAND

Channel	Frequency (MHz)	26 dB BW (MHz)	99% BW (MHz)
Low	5500	19.98	16.718
Mid	5580	19.97	16.747
High	5700	20.23	16.706
CH144	5720	19.92	16.739

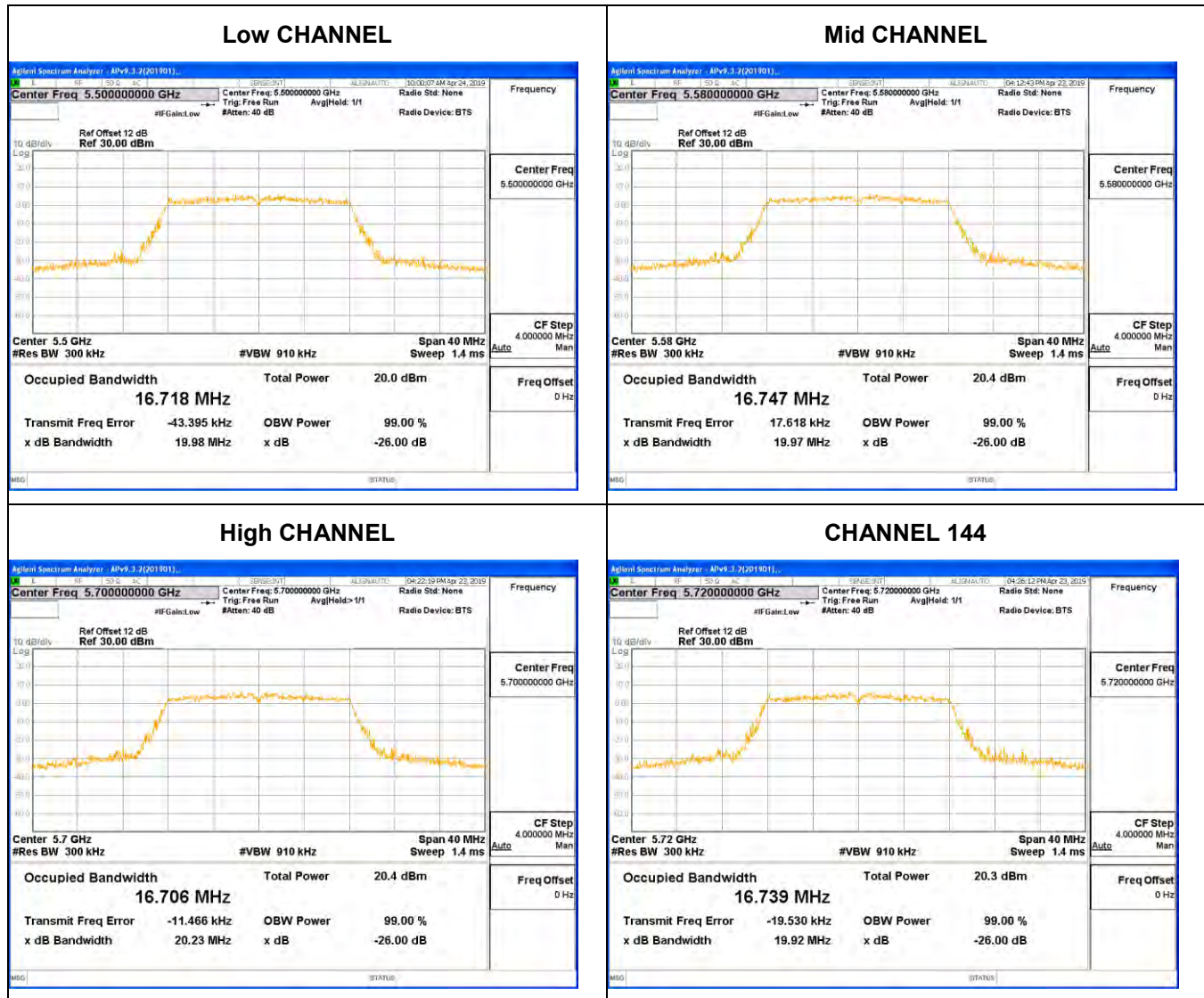



UNII-3 BAND

Channel	Frequency (MHz)	6 dB BW (MHz)	99% BW (MHz)	Limit For 6dB BW (KHz)	Result
Low	5745	16.505	16.698	500	PASS
Mid	5785	16.410	16.715	500	PASS
High	5825	16.430	16.785	500	PASS
CH144	5720	3.250	/	500	PASS

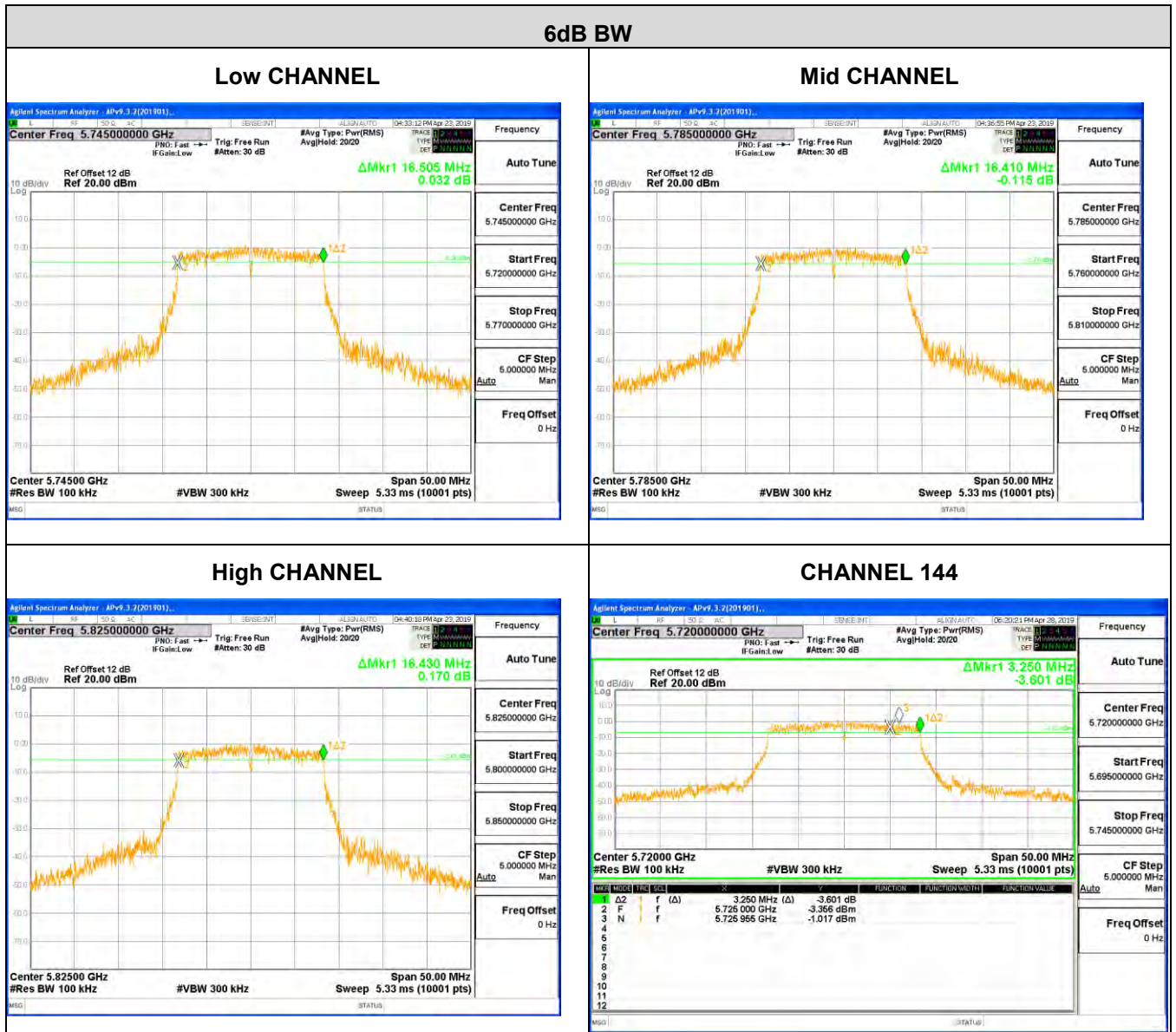

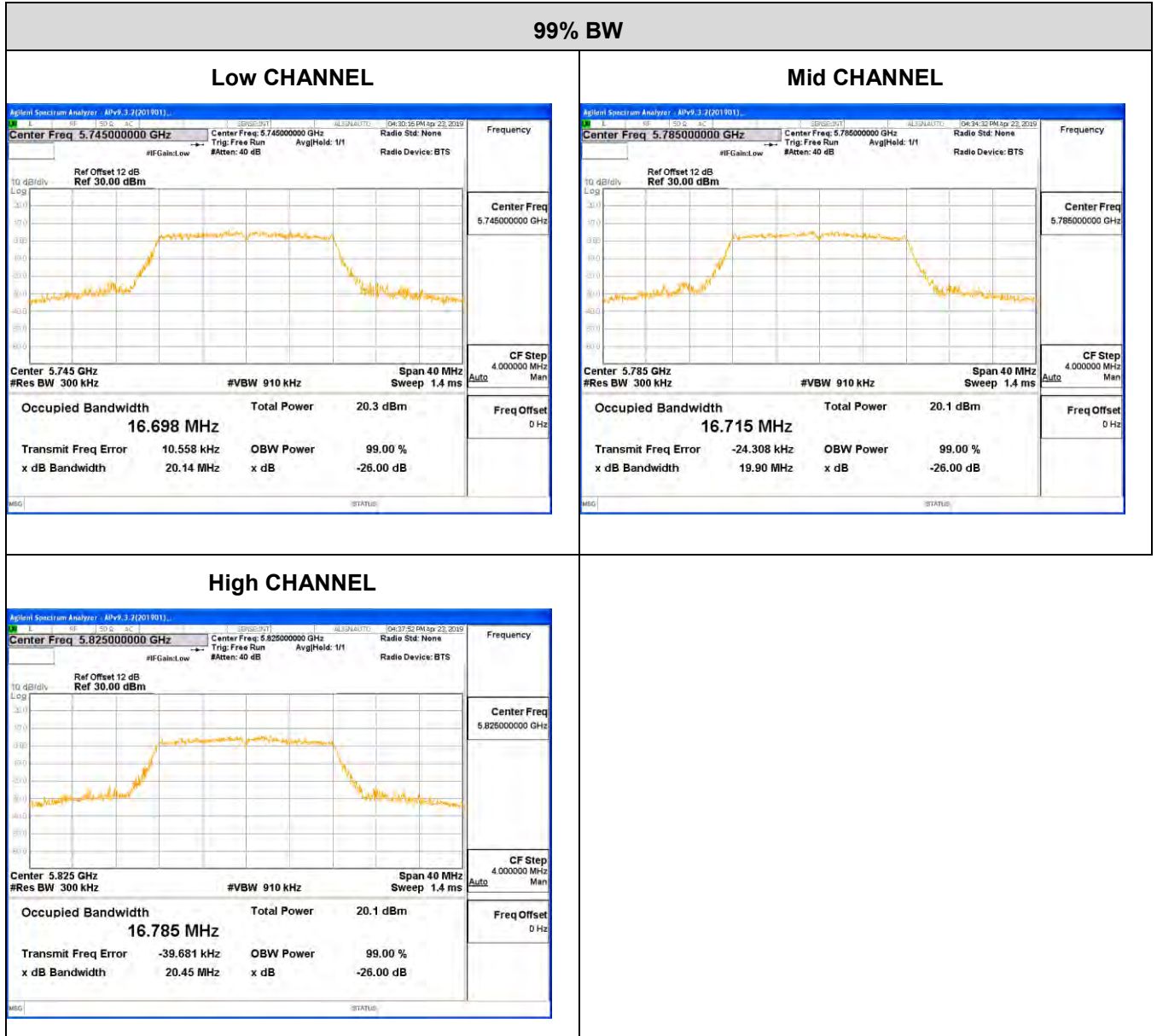

Note: All the modes and antenna ports had been tested, only the worst data recorded in the report.



7.2.2. 802.11n HT20 MIMO MODE

ANT2 WORST CASE

UNII-1 BAND

Channel	Frequency (MHz)	26 dB BW (MHz)	99% BW (MHz)
Low	5180	20.21	17.675
Mid	5200	20.10	17.662
High	5240	19.94	17.667

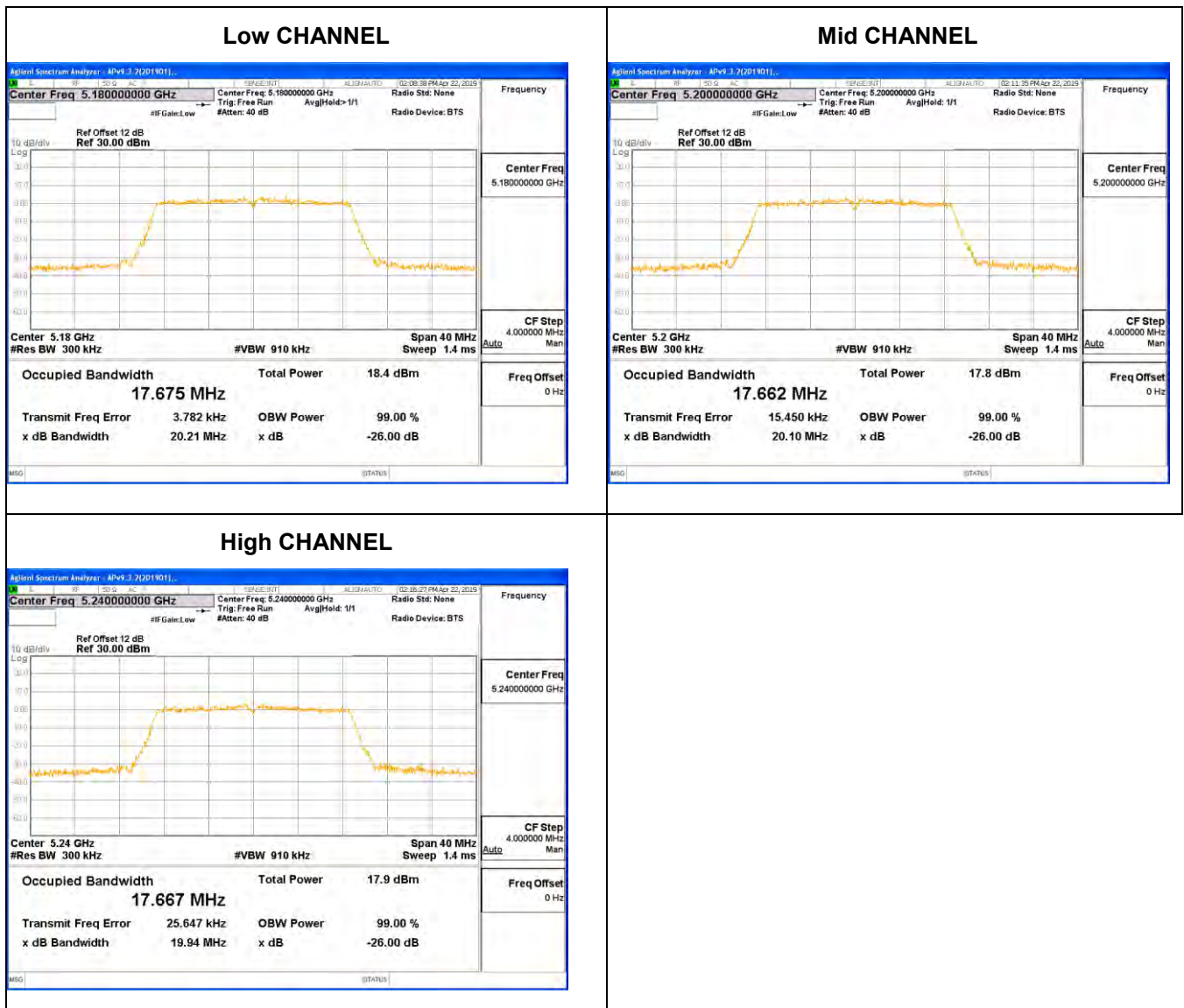



UNII-2A BAND

Channel	Frequency (MHz)	26 dB BW (MHz)	99% BW (MHz)
Low	5260	20.27	17.674
Mid	5300	20.31	17.707
High	5320	20.23	17.692

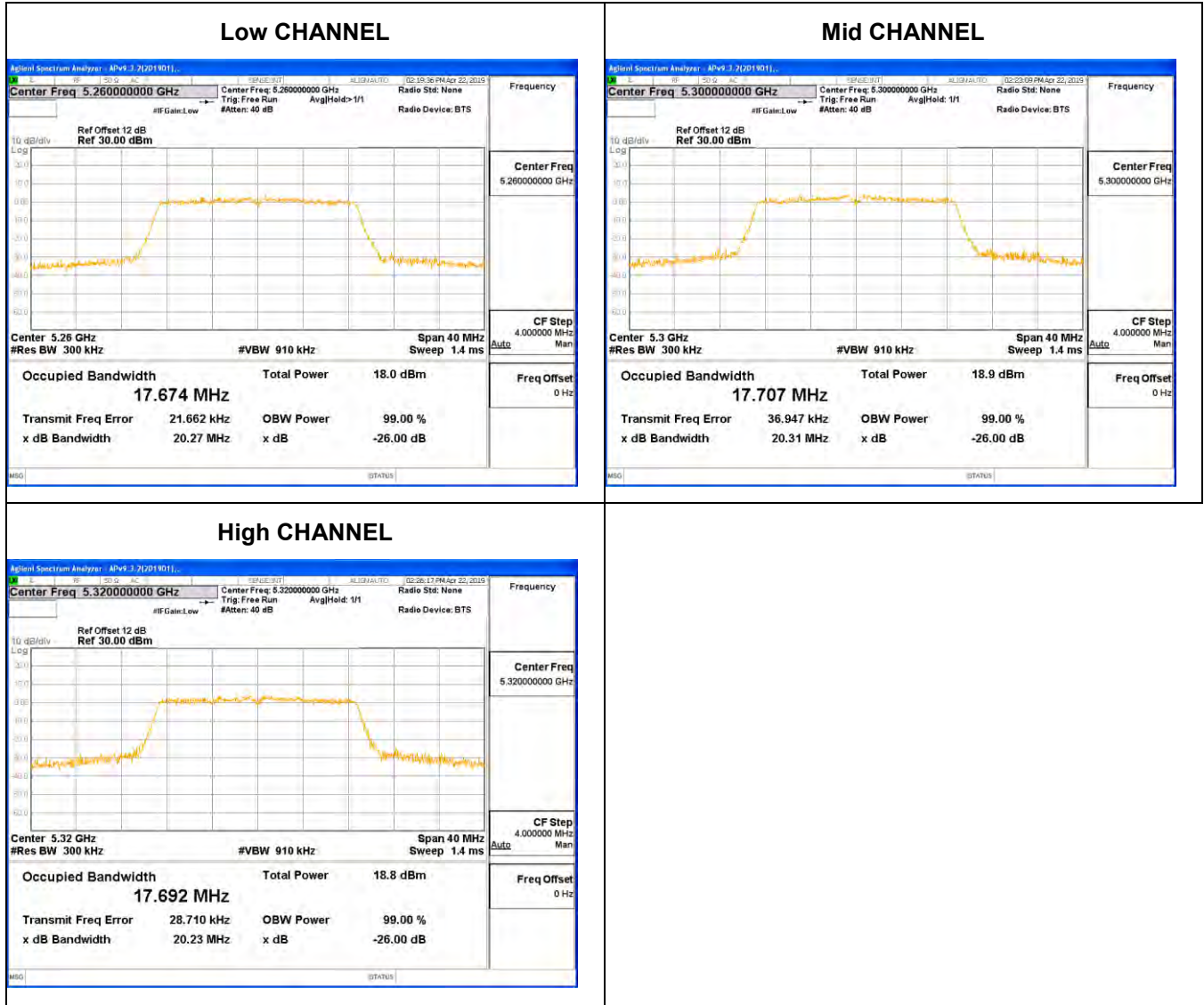



UNII-2C BAND

Channel	Frequency (MHz)	26 dB BW (MHz)	99% BW (MHz)
Low	5500	20.06	17.641
Mid	5580	20.01	17.664
High	5700	19.97	17.654
CH144	5720	20.05	17.669

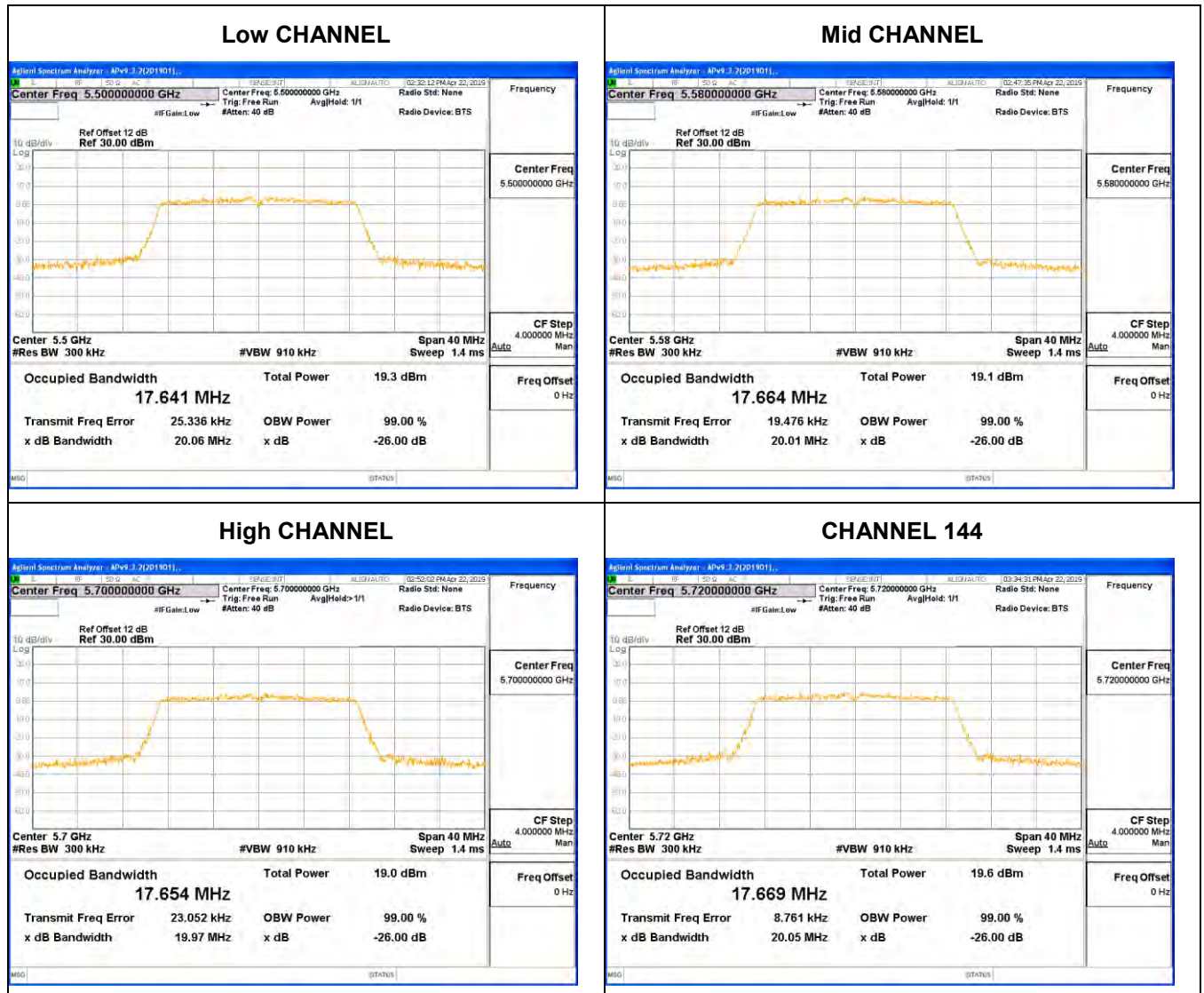



UNII-3 BAND

Channel	Frequency (MHz)	6 dB BW (MHz)	99% BW (MHz)	Limit For 6dB BW (KHz)	Result
Low	5745	17.645	17.657	500	PASS
Mid	5785	17.630	17.640	500	PASS
High	5825	17.615	17.642	500	PASS
CH144	5720	3.870	/	500	PASS

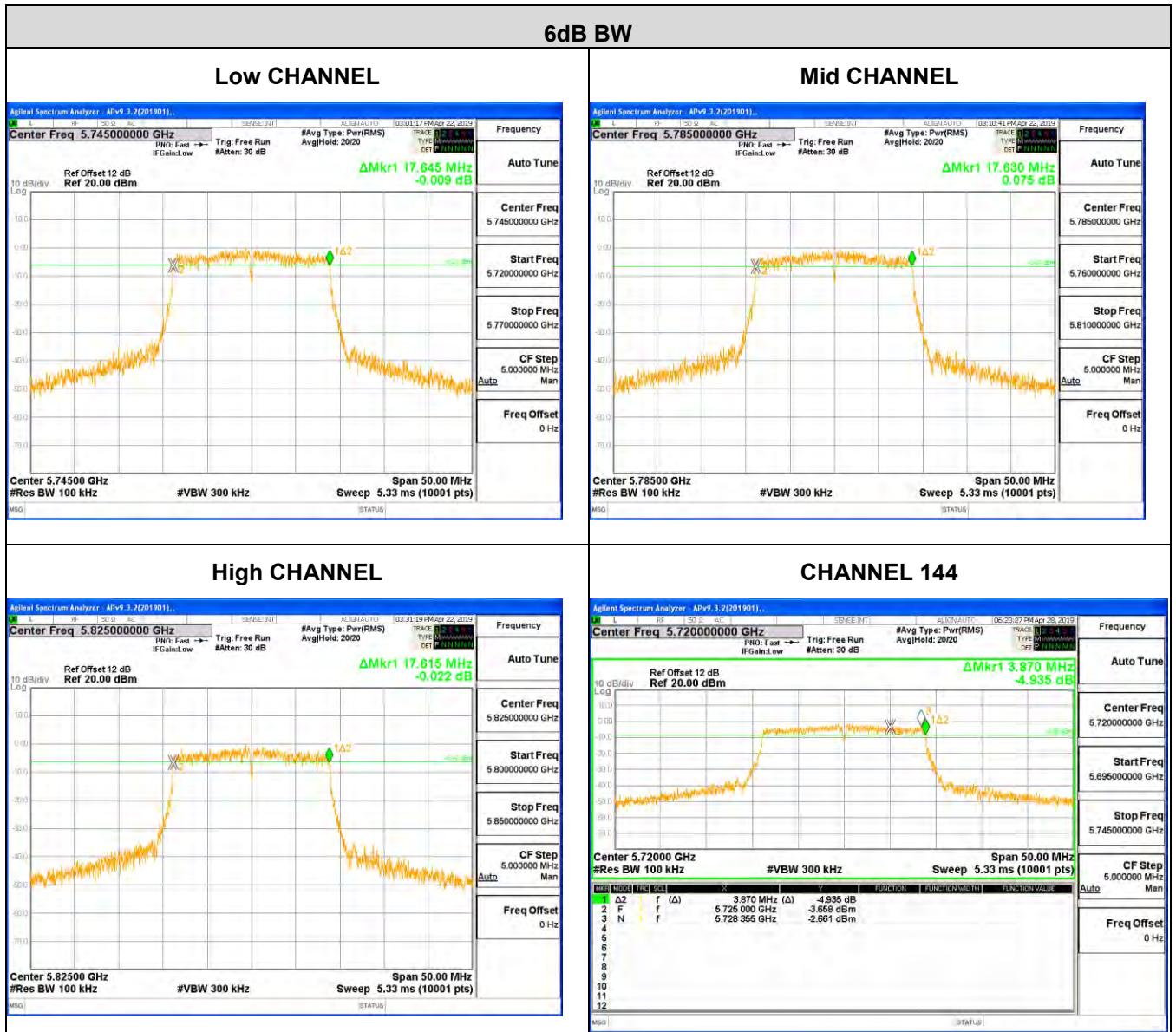



Note: All the modes and antenna ports had been tested, only the worst data recorded in the report.



7.2.3. 802.11n HT40 MIMO MODE

ANT2 WORST CASE

UNII-1 BAND

Channel	Frequency (MHz)	26 dB BW (MHz)	99% BW (MHz)
Low	5190	40.58	36.096
High	5230	40.77	36.121

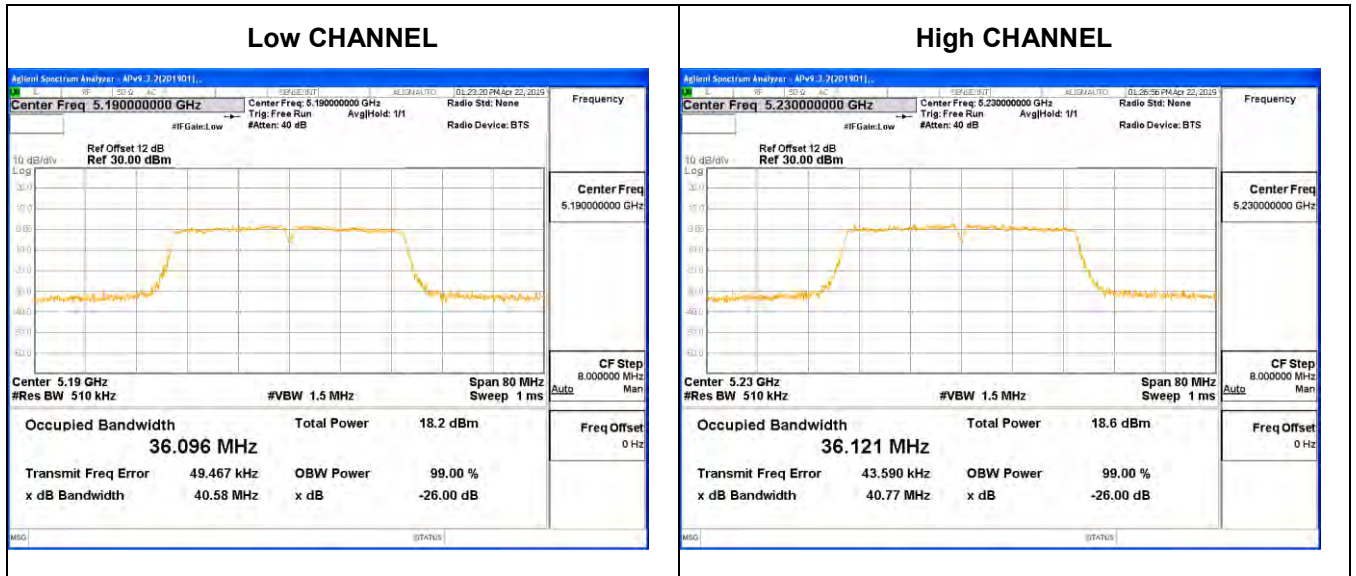



UNII-2A BAND

Channel	Frequency (MHz)	26 dB BW (MHz)	99% BW (MHz)
Low	5270	41.03	36.099
High	5310	40.71	36.120

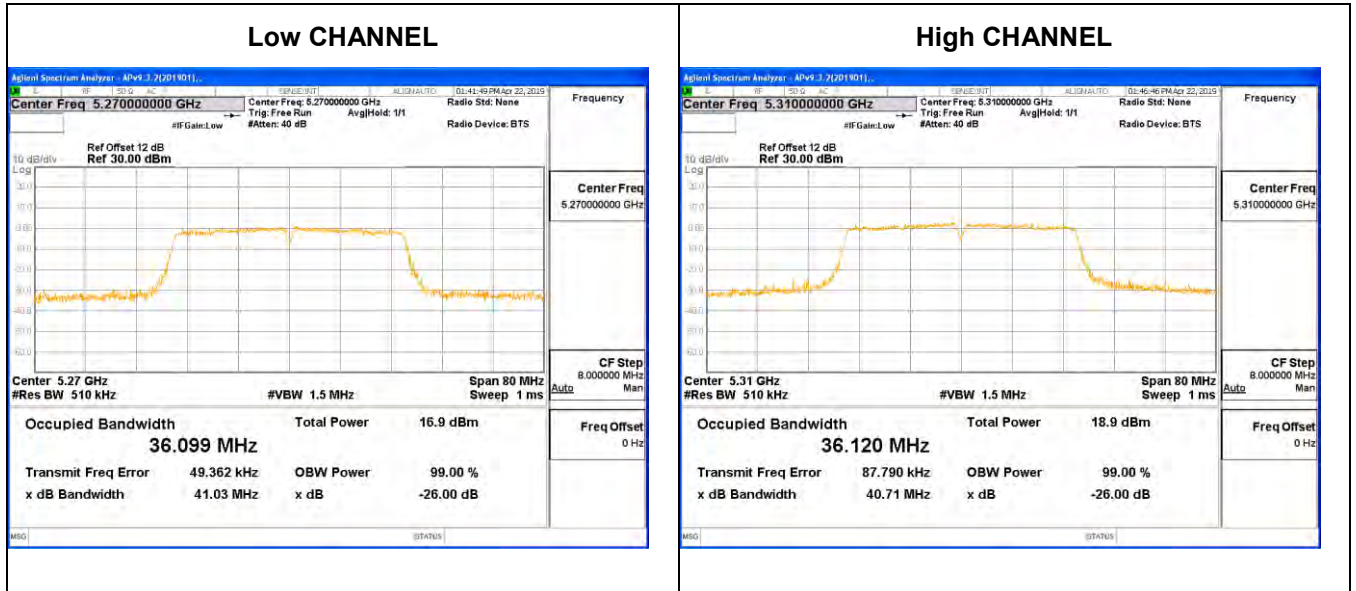



UNII-2C BAND

Channel	Frequency (MHz)	26 dB BW (MHz)	99% BW (MHz)
Low	5510	40.76	36.065
Mid	5550	40.13	36.046
High	5670	40.85	36.077
CH142	5710	40.85	36.071

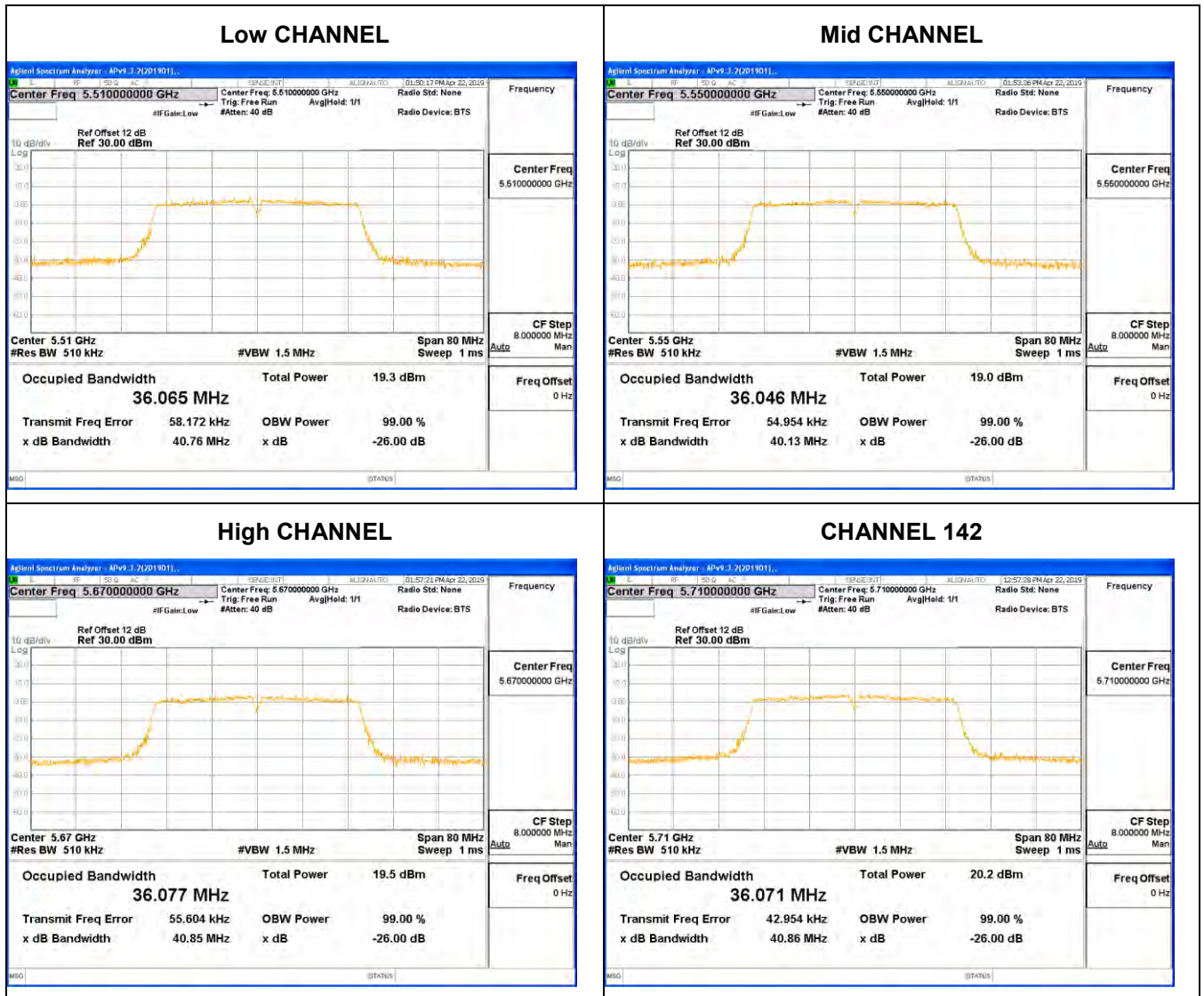



UNII-3 BAND

Channel	Frequency (MHz)	6 dB BW (MHz)	99% BW (MHz)	Limit (KHz)	Result
Low	5755	36.32	36.094	500	PASS
High	5795	36.36	36.083	500	PASS
CH142	5710	3.19	/	500	PASS

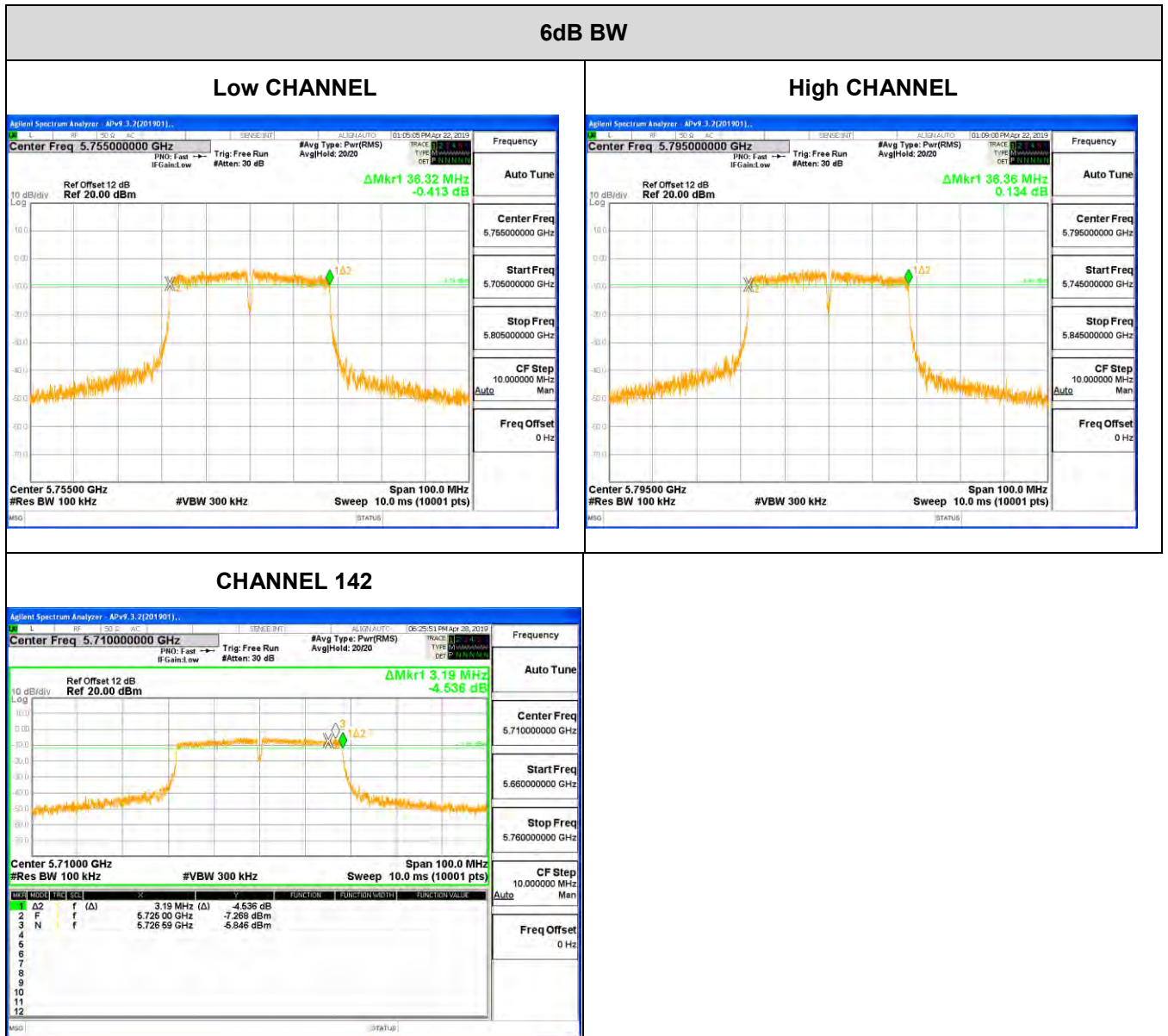

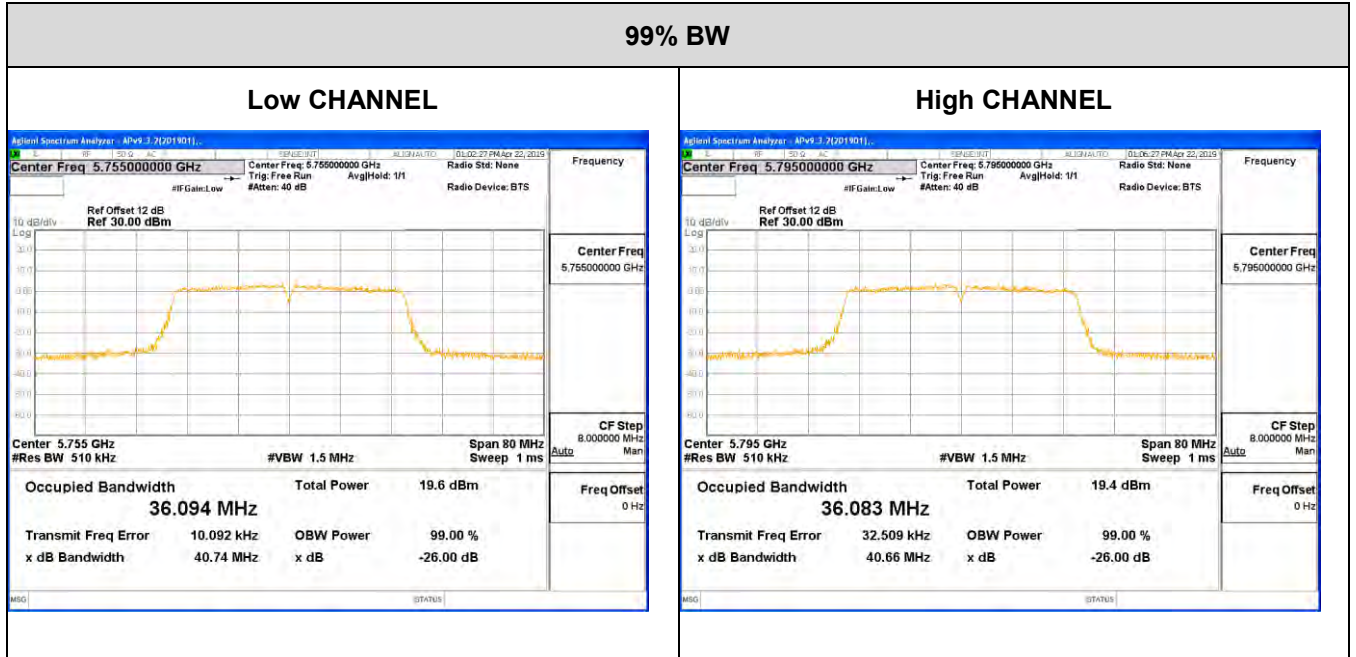

Note: All the modes and antenna ports had been tested, only the worst data recorded in the report.



7.2.4. 802.11ac VHT80 MIMO MODE

ANT2 WORST CASE

UNII-1 BAND

Channel	Frequency (MHz)	26 dB BW (MHz)	99% BW (MHz)
Mid	5210	80.50	75.076

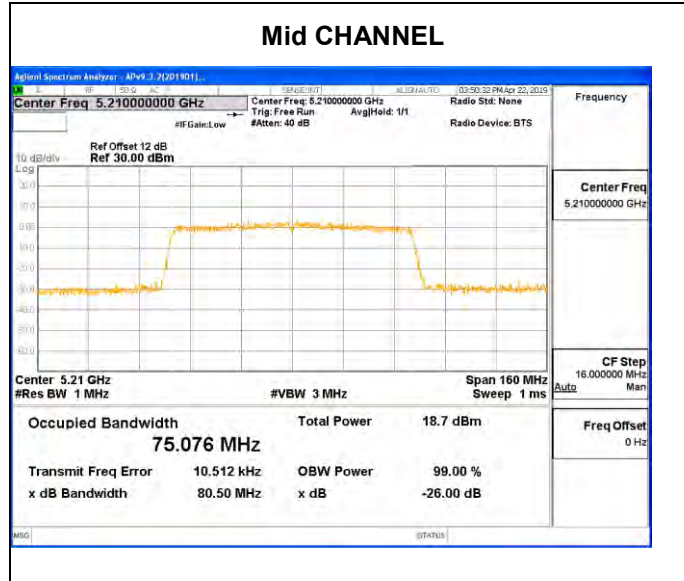



UNII-2A BAND

Channel	Frequency (MHz)	26 dB BW (MHz)	99% BW (MHz)
Mid	5290	81.12	75.107

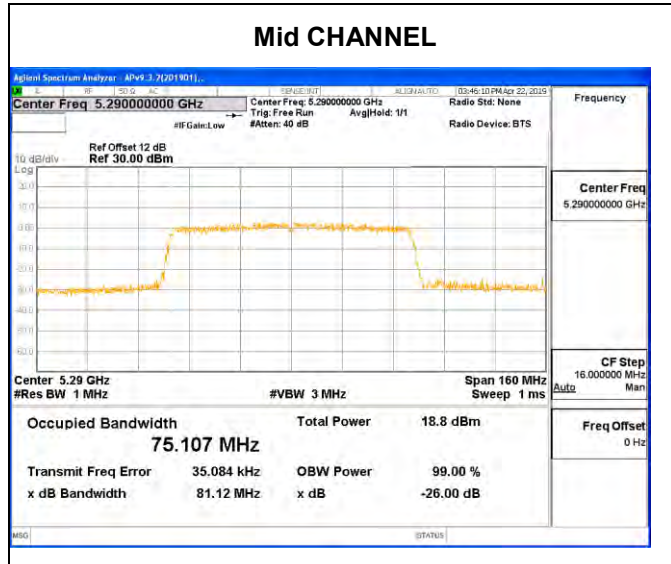



UNII-2C BAND

Channel	Frequency (MHz)	26 dB BW (MHz)	99% BW (MHz)
Low	5530	80.95	75.143
High	5610	80.97	75.137
CH138	5690	80.41	74.952

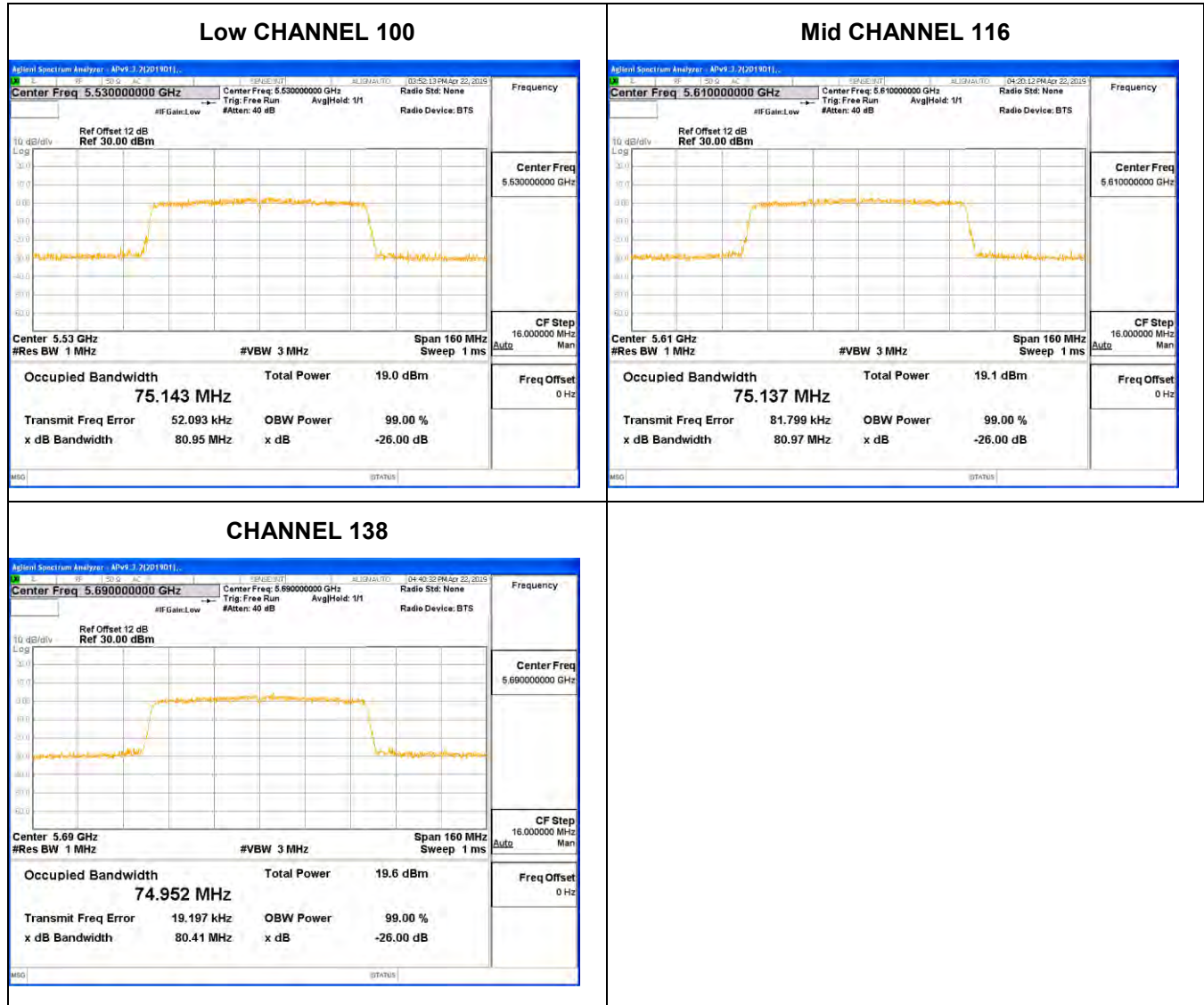



UNII-3 BAND

Channel	Frequency (MHz)	6 dB BW (MHz)	99% BW (MHz)	Limit For 6dB BW (KHz)	Result
Mid	5775	74.74	75.060	500	PASS
CH138	5690	3.18	/	500	PASS

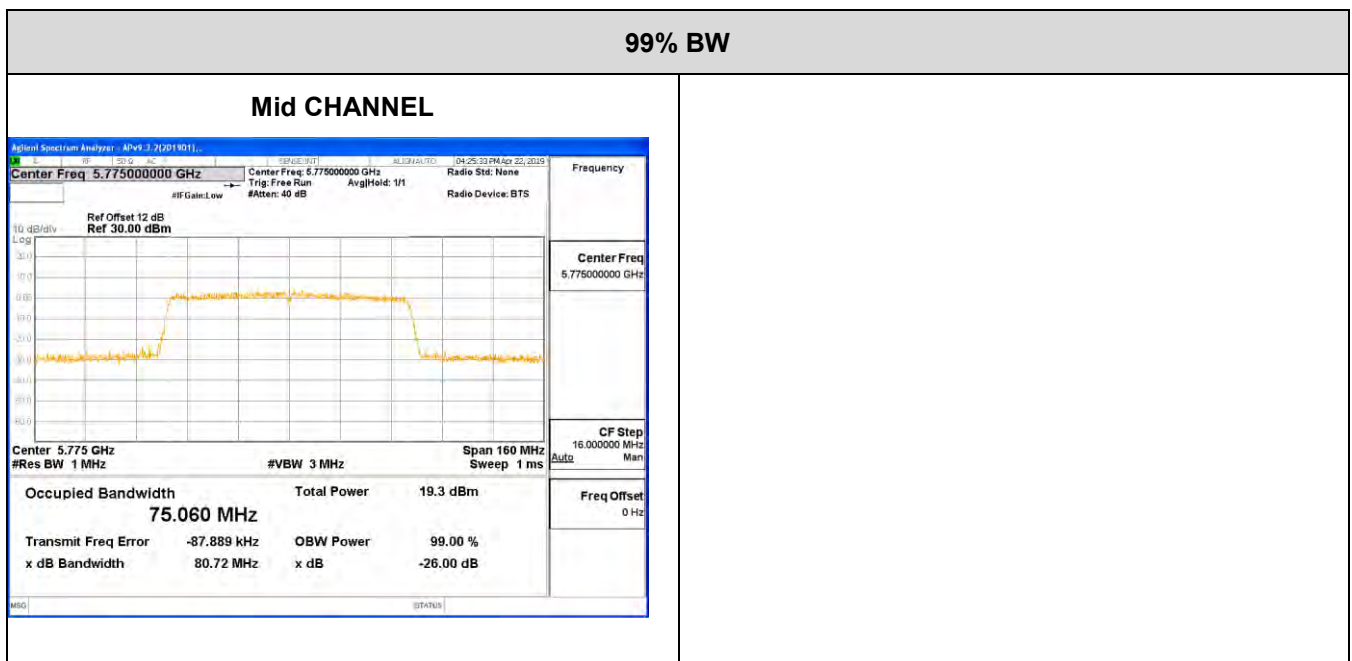
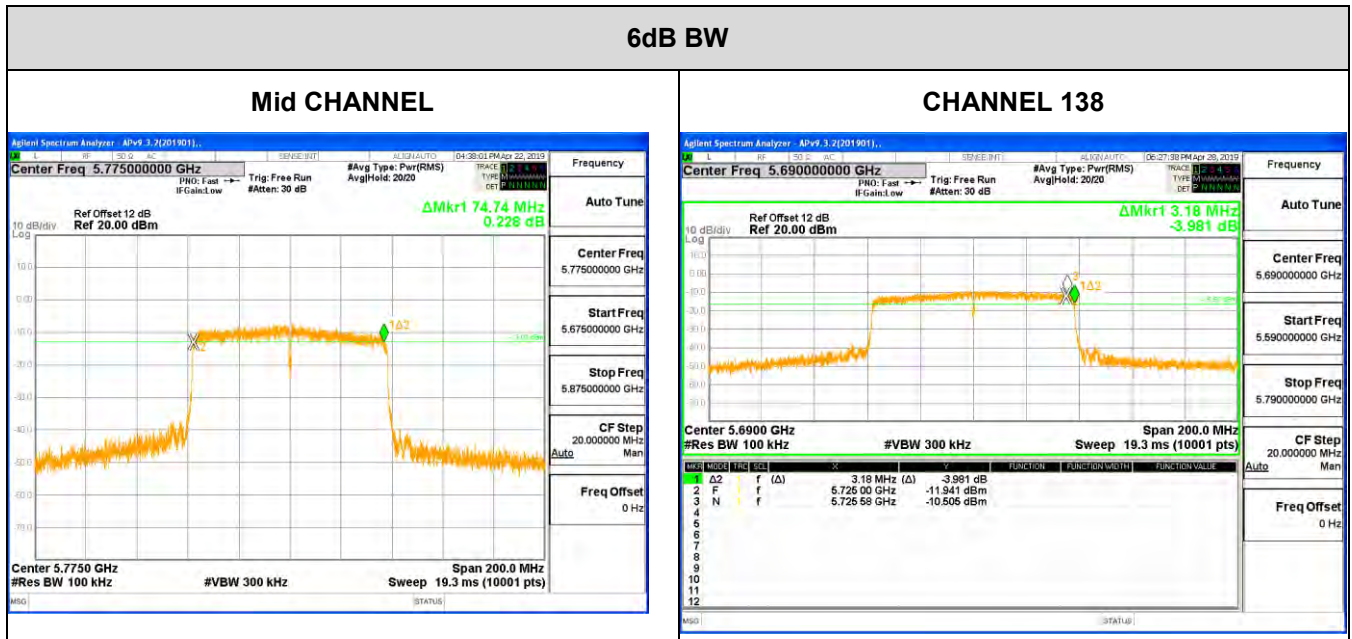

Note: All the modes and antenna ports had been tested, only the worst data recorded in the report.

7.3. MAXIMUM CONDUCTED OUTPUT POWER

LIMITS

FCC Part15, Subpart E/ RSS-247		
Test Item	Limit	Frequency Range (MHz)
Conducted Output Power	For FCC outdoor access point:1W (30dBm)	5150-5250
	250mW (24dBm) or $10 + 10 \log_{10} B$	5250-5350
	250mW (24dBm) or $10 + 10 \log_{10} B$	For FCC:5470-5725 For IC:5470-5600 5650-5725
	1 Watt (30dBm)	5725-5850
<p>Note:</p> <p>1. If transmitting antennas of directional gain greater than 6 dBi are used, both the maximum conducted output power and the maximum power spectral density shall be reduced by the amount in dB that the directional gain of the antenna exceeds 6dBi.</p> <p>2. Directional gain = $10\log[(10^{G_{1/2}/20} + 10^{G_{2/20}})^2 / N_{ANT}] = 4.59 < 6\text{dBi}$, where N_{ANT} is the number of outputs, $G_{1/2}$ is the Antenna gain.</p> <p>3. B is the 26 dB emission bandwidth in megahertz</p>		

TEST PROCEDURE

Refer to KDB 789033 D02 General UNII Test Procedures New Rules v02r01

Connect the EUT to the a broadband average RF power meter, the power meter shall have a video bandwidth that is greater than or equal to the bandwidth and shall utilize a fast-responding diode detector.

Straddle channel power is measured using PXA spectrum analyzer.

TEST SETUP

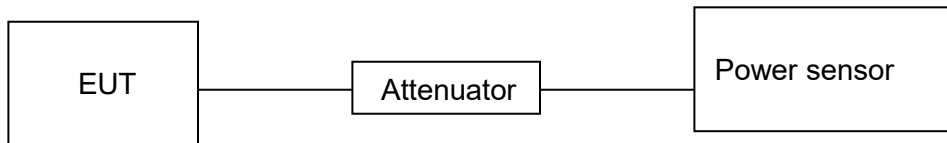

TEST ENVIRONMENT

Temperature	24.6°C	Relative Humidity	56%
Atmosphere Pressure	101kPa	Test Voltage	DC 5V



RESULTS

7.3.1. UNII-1 BAND

Mode	Frequency (MHz)	Chain	CONDUCTED POWER (dBm)		Limit (dBm)	EIRP (dBm)	EIRP Limit (dBm)
			Single	Total			
a	5180	1	13.91		24	15.48	23
		2	13.66			15.32	
	5200	1	14.73		24	16.30	23
		2	14.06			15.72	
	5240	1	14.71		24	16.28	23
		2	14.24			15.90	
n HT20	5180	1	13.37	16.11	30	17.77	23
		2	12.82				
	5200	1	13.15	15.90	30	17.56	23
		2	12.62				
	5240	1	13.14	16.03	30	17.69	23
		2	12.90				
ac HT20	5180	1	13.54	16.16	30	17.82	23
		2	12.73				
	5200	1	13.23	15.73	30	17.39	23
		2	12.15				
	5240	1	13.54	15.98	30	17.64	23
		2	12.31				
n HT40	5190	1	13.83	16.31	30	17.97	23
		2	12.70				
	5230	1	13.71	16.19	30	17.85	23
		2	12.57				
ac HT40	5190	1	13.82	16.07	30	17.73	23
		2	12.13				
	5230	1	13.50	16.04	30	17.70	23
		2	12.51				
ac HT80	5210	1	12.88	15.57	30	17.23	23
		2	12.22				

Note: 1. Conducted Power=Meas. Level+ Correction Factor
 2. About correction Factor please refer to section 7.1
 3. EIRP=conducted Power + Antenna Gain



7.3.2. UNII-2A BAND

Mode	Frequency (MHz)	Chain	CONDUCTED POWER (dBm)		Limit (dBm)
			Single	Total	
a	5260	1	14.85		24
		2	13.74		
	5280	1	14.41		24
		2	14.27		
	5320	1	14.19		24
		2	14.36		
n HT20	5260	1	13.75	16.13	24
		2	12.39		
	5300	1	13.63	16.55	24
		2	13.44		
	5320	1	13.81	16.74	24
		2	13.65		
ac HT20	5260	1	13.61	16.04	24
		2	12.36		
	5300	1	13.59	16.52	24
		2	13.42		
	5320	1	13.74	16.74	24
		2	13.72		
n HT40	5270	1	13.82	16.17	24
		2	12.39		
	5310	1	13.74	16.59	24
		2	13.42		
ac HT40	5270	1	12.77	15.50	24
		2	12.19		
	5310	1	13.94	16.42	24
		2	12.81		
ac HT80	5290	1	12.83	15.50	24
		2	12.11		

Note: 1. Conducted Power=Meas. Level+ Correction Factor
 2. About correction Factor please refer to section 7.1
 3. EIRP=conducted Power + Antenna Gain



7.3.3. UNII-2C BAND

Mode	Frequency (MHz)	Chain	CONDUCTED POWER (dBm)		Limit (dBm)
			Single	Total	
a	5500	1	13.87		24
		2	14.86		
	5580	1	14.08		24
		2	14.59		
	5700	1	14.62		24
		2	14.95		
2		14.04			
n HT20	5500	1	13.02	16.50	24
		2	13.91		
	5580	1	13.39	16.09	24
		2	12.74		
	5700	1	13.82	16.89	24
		2	13.93		
2		12.57			
ac HT20	5500	1	13.10	16.58	24
		2	13.99		
	5580	1	13.01	16.10	24
		2	13.16		
	5700	1	13.94	16.88	24
		2	13.80		
2		12.97			



n HT40	5510	1	13.29	16.70	24
		2	14.05		
	5550	1	13.09	16.58	24
		2	14.00		
	5670	1	13.86	16.91	24
		2	13.93		
2		13.60			
ac HT40	5510	1	13.42	16.58	24
		2	13.72		
	5550	1	13.04	16.34	24
		2	13.61		
	5670	1	13.98	16.95	24
		2	13.89		
2		13.93			
ac HT80	5530	1	11.70	15.27	24
		2	12.75		
	5610	1	12.77	15.70	24
		2	12.61		
		2	12.78		

Note: 1. Conducted Power=Meas. Level+ Correction Factor
2. About correction Factor please refer to section 7.1



7.3.4. STRADDLE CHANNEL

UNII-2C BAND

Mode	Frequency (MHz)	ANT	Maximum AVG Conducted Output Power (dBm)		Min 26dB BW(MHz)	Limit (dBm)
			Single	Total		
a	5720	1	12.691	N/A	15.25	22.8
		2	13.572			
n HT20	5720	1	13.254	15.96	15.20	22.8
		2	12.625			
ac HT20	5720	1	13.261	16.15	15.20	22.8
		2	13.017			
n HT40	5710	1	13.832	14.34	35.80	24
		2	13.362			
ac HT40	5710	1	13.811	14.44	35.85	24
		2	13.959			
ac HT80	5690	1	12.908	14.10	76	24
		2	12.795			

Note: 1. Conducted Power=Meas. Level+ Correction Factor
2. About correction Factor please refer to section 7.1

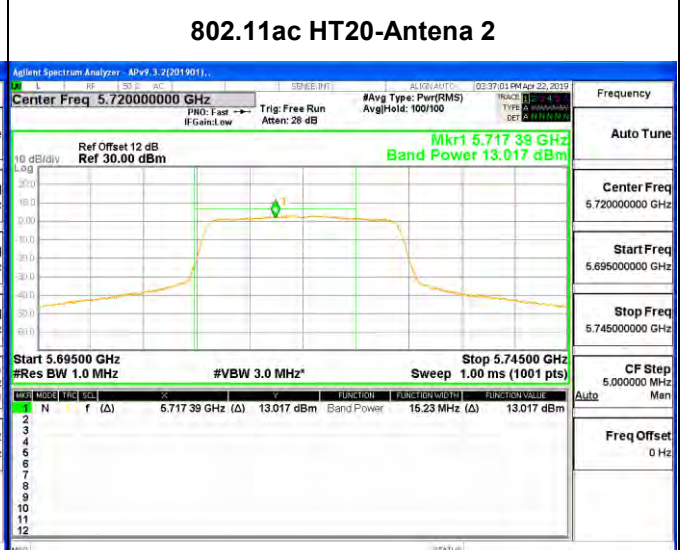
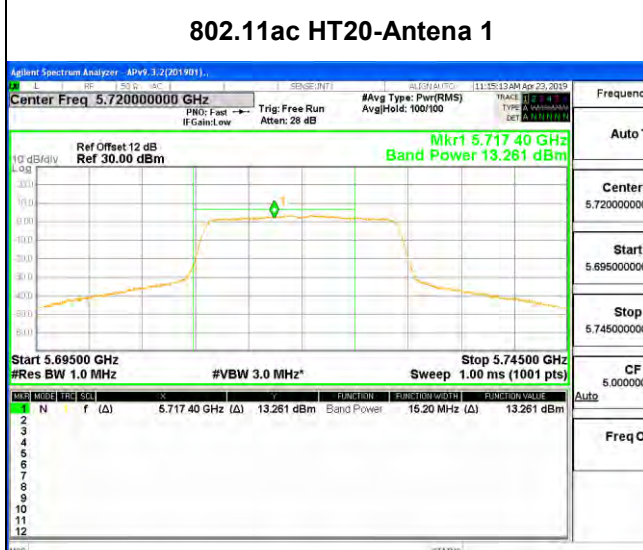
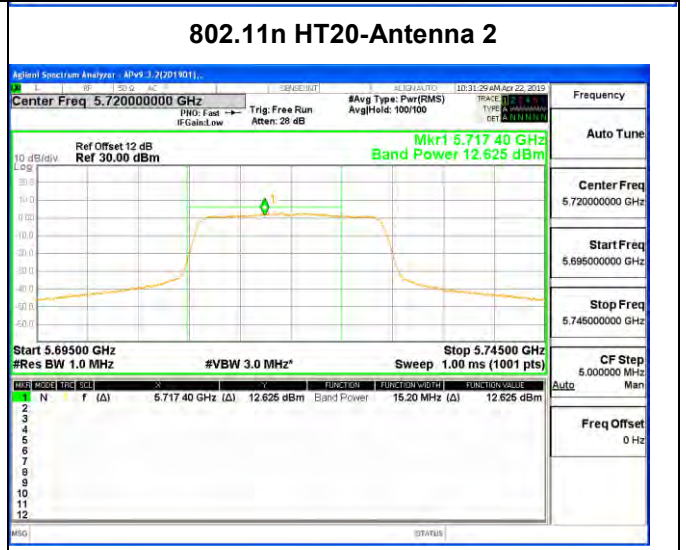
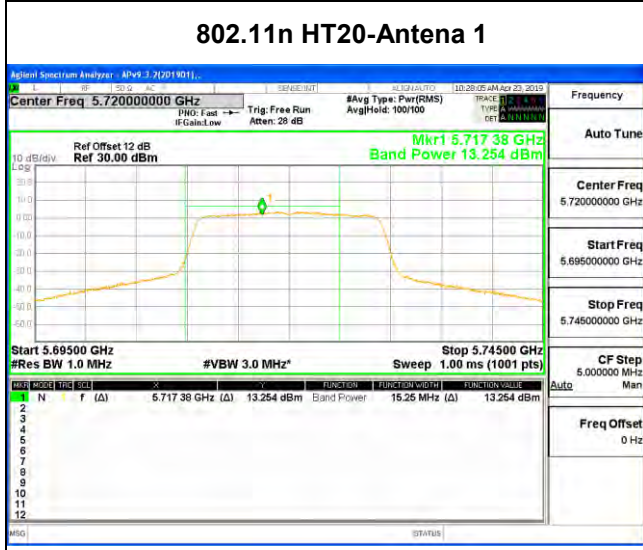
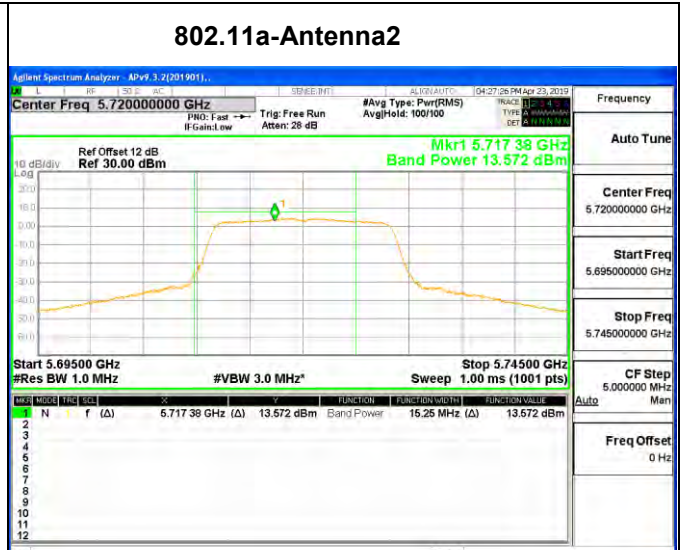
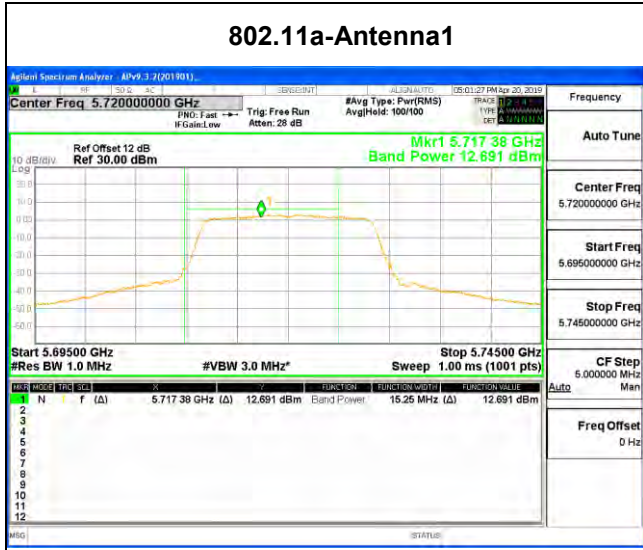

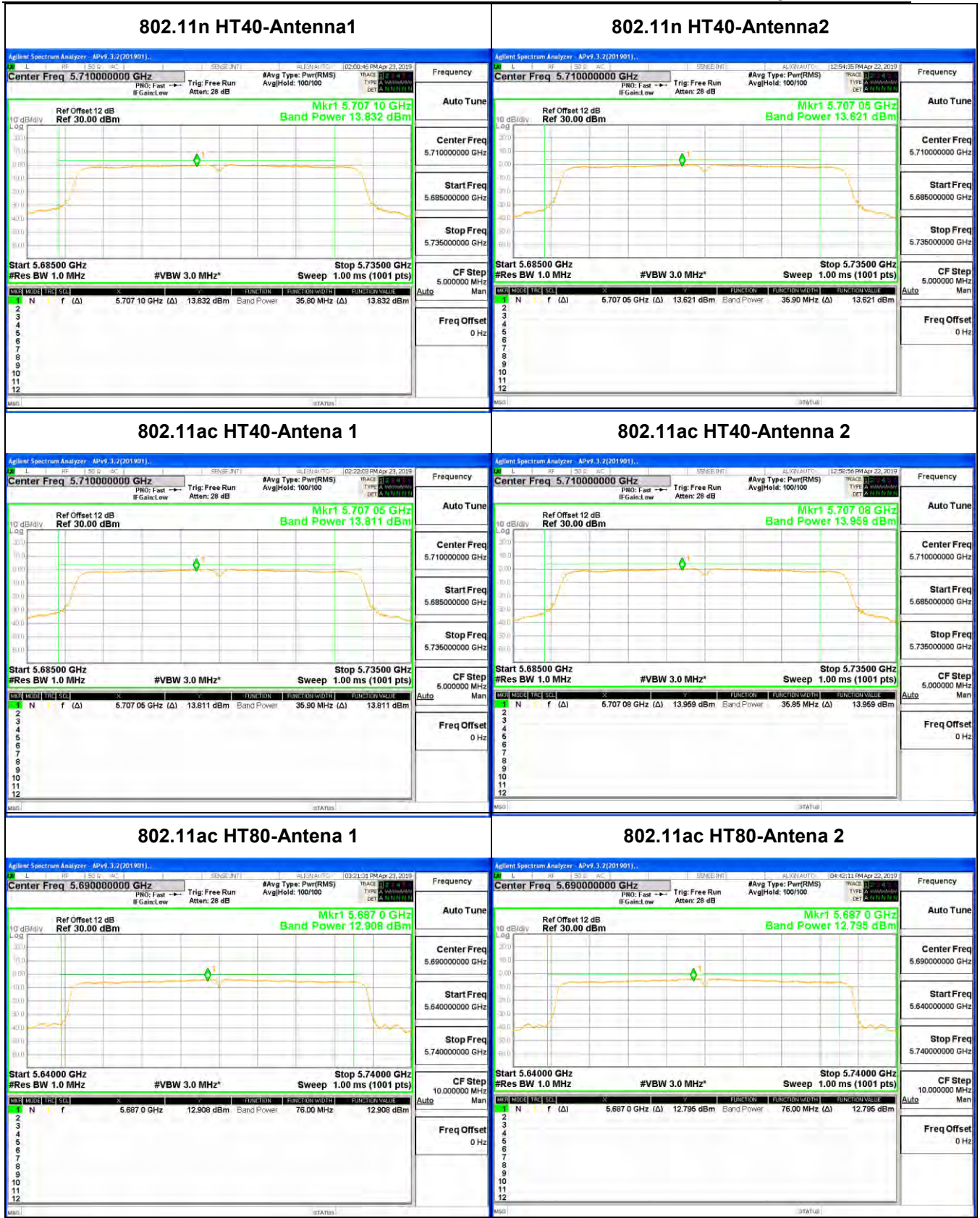



UNII-3 BAND

Mode	Frequency (MHz)	ANT	Maximum AVG Conducted Output Power (dBm)		Min 26dB BW(MHz)	Limit (dBm)
			Single	Total		
a	5720	1	5.942	N/A	5.25	30
		2	6.126			
n HT20	5720	1	6.969	9.61	5.20	30
		2	6.203			
ac HT20	5720	1	7.008	9.81	5.20	30
		2	6.587			
n HT40	5710	1	3.036	5.81	5.80	30
		2	2.550			
ac HT40	5710	1	2.994	5.91	5.85	30
		2	2.809			
ac HT80	5690	1	-2.034	0.66	6	30
		2	-2.691			

Note: 1. Conducted Power=Meas. Level+ Correction Factor
2. About correction Factor please refer to section 7.1

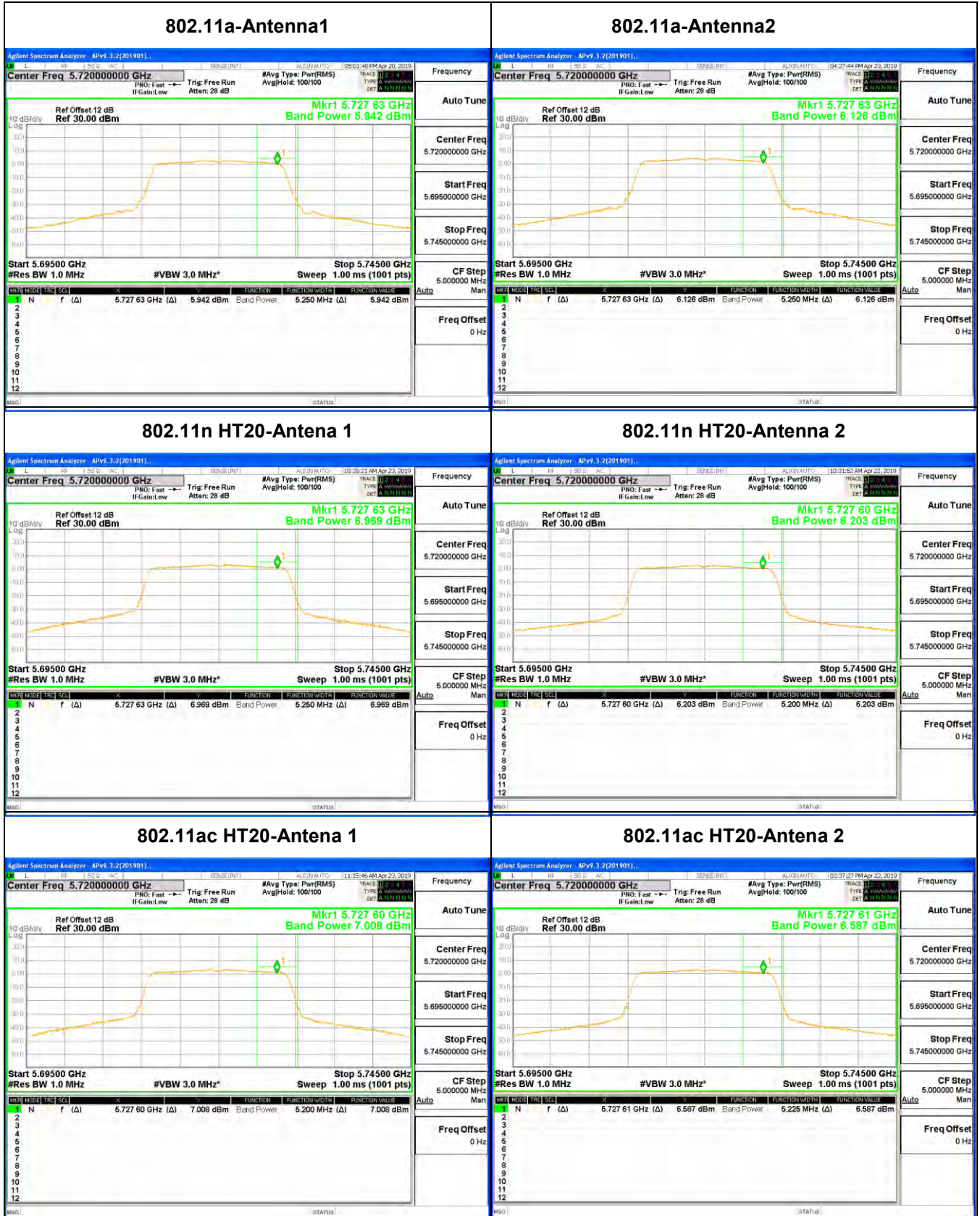

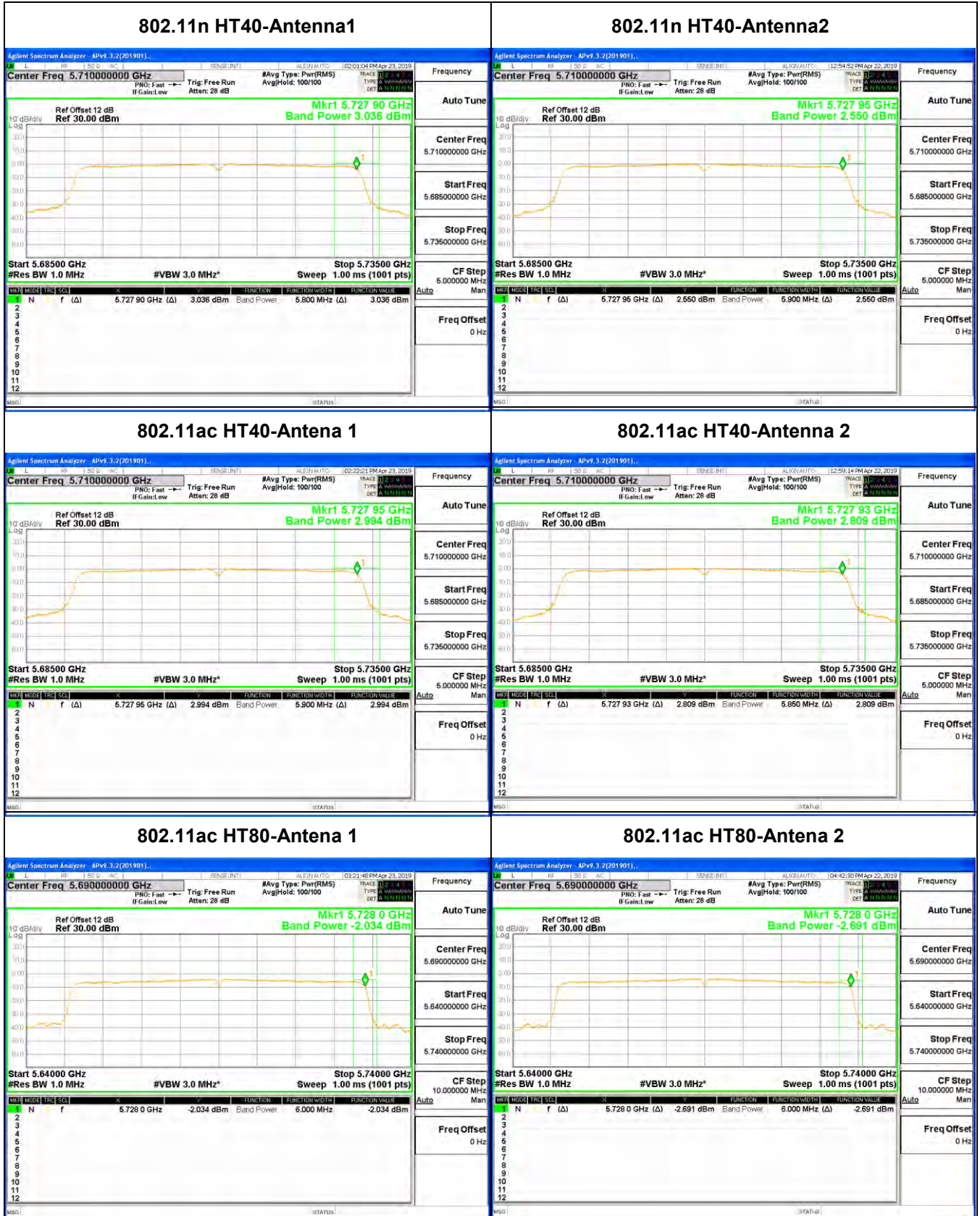



7.3.5. UNII-3 BAND

Mode	Frequency (MHz)	Chain	CONDUCTED POWER (dBm)		Limit (dBm)
			Single	Total	
a	5745	1	14.80		30
		2	14.87		
	5785	1	14.82		30
		2	14.35		
	5825	1	14.18		30
		2	14.31		
n HT20	5745	1	13.58	16.46	30
		2	13.31		
	5785	1	13.60	16.27	30
		2	12.89		
	5825	1	13.24	15.97	30
		2	12.67		
ac HT20	5745	1	13.67	16.84	30
		2	13.98		
	5785	1	13.53	16.51	30
		2	13.47		
	5825	1	13.48	16.46	30
		2	13.42		
n HT40	5755	1	13.75	16.36	30
		2	12.90		
	5795	1	13.61	16.41	30
		2	13.17		
ac HT40	5755	1	13.69	16.70	30
		2	13.69		
	5795	1	13.51	16.51	30
		2	13.48		
ac HT80	5775	1	12.82	15.78	30
		2	12.72		

Note: 1. Conducted Power=Meas. Level+ Correction Factor
2. About correction Factor please refer to section 7.1



7.4. POWER SPECTRAL DENSITY

LIMITS

CFR 47 FCC Part15, Subpart E ISED RSS-247		
Test Item	Limit	Frequency Range (MHz)
Power Spectral Density	For FCC: Other than Mobile and portable:17dBm/MHz Mobile and portable:11dBm/MHz	5150-5250
	For RSS: e.i.r.p. 10dBm/MHz	
	11dBm/MHz	5250-5350
	11dBm/MHz	For FCC:5470-5725 For IC:5470-5600 5650-5725
	30dBm/500kHz	5725-5850
<p>Note:</p> <p>1. If transmitting antennas of directional gain greater than 6 dBi are used, both the maximum conducted output power and the maximum power spectral density shall be reduced by the amount in dB that the directional gain of the antenna exceeds 6dBi.</p> <p>2. Directional gain = $10\log[(10^{G1/20} + 10^{G2/20})^2 / N_{ANT}] = 4.59 < 6\text{dBi}$, where N_{ANT} is the number of outputs, $G_{1/2}$ is the Antenna gain.</p>		

TEST PROCEDURE

Connect the UUT to the spectrum analyser and use the following settings:

For U-NII-1, U-NII-2A and U-NII-2C band:

Center Frequency	The center frequency of the channel under test
Detector	RMS
RBW	1MHz
VBW	$\geq 3 \times \text{RBW}$
Span	Encompass the entire emissions bandwidth (EBW) of the signal
Trace	Max hold
Sweep time	Auto

For U-NII-3:

Center Frequency	The center frequency of the channel under test
Detector	RMS
RBW	500kHz
VBW	$\geq 3 \times \text{RBW}$
Span	Encompass the entire emissions bandwidth (EBW) of the signal
Trace	Max hold
Sweep time	Auto



Allow trace to fully stabilize and use the peak marker function to determine the maximum amplitude level within the RBW.

TEST SETUP

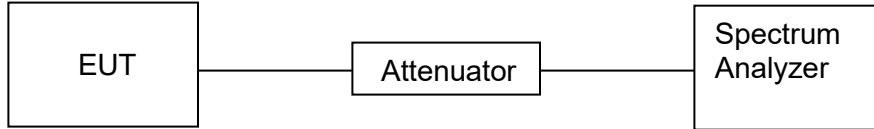

TEST ENVIRONMENT

Temperature	24.6°C	Relative Humidity	56%
Atmosphere Pressure	101kPa	Test Voltage	DC 5V

RESULTS



7.4.1. 802.11a SISO MODE

UNII-1 BAND

Test Channel	Frequency (MHz)	ANT	Meas. Level (dBm/MHz)		Limit (dBm/MHz)
			Single	Total	
Low	5180	1	3.306	N/A	11
		2	3.122		
Middle	5200	1	4.319		
		2	3.689		
High	5240	1	4.132		
		2	3.737		

Note: 1.PSD=Meas. Level+ Correction Factor
2. About correction Factor please refer to section 7.1

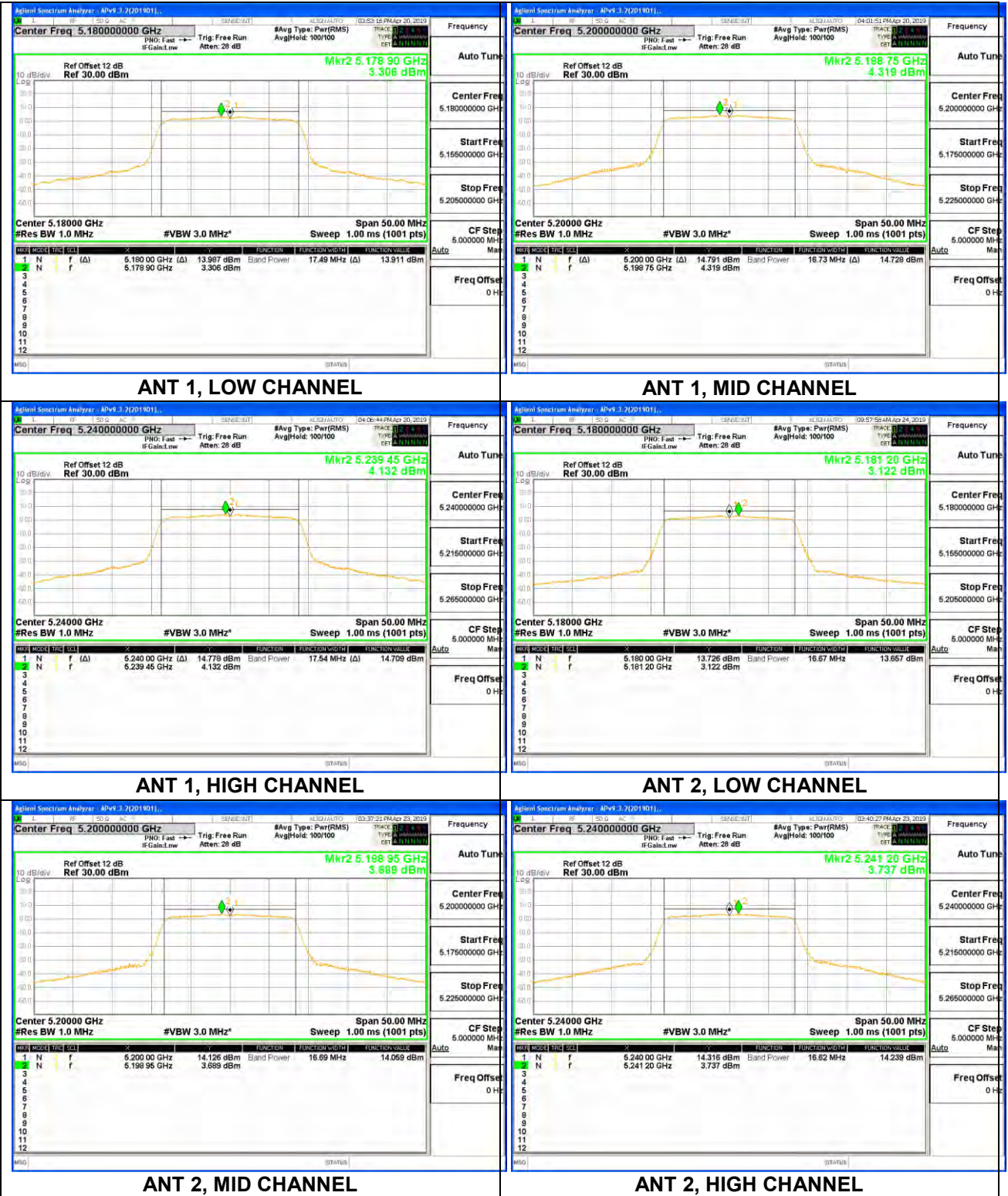



UNII-2A BAND

Test Channel	Frequency (MHz)	ANT	Meas. Level (dBm/MHz)		Limit (dBm/MHz)
			Single	Total	
Low	5260	1	4.507	N/A	11
		2	3.278		
Middle	5300	1	4.067		
		2	3.768		
High	5320	1	3.900		
		2	4.176		

Note: 1.PSD=Meas. Level+ Correction Factor
2. About correction Factor please refer to section 7.1





UNII-2C BAND

Test Channel	Frequency (MHz)	ANT	Meas. Level (dBm/MHz)		Limit (dBm/MHz)
			Single	Total	
Low	5500	1	3.436	N/A	11
		2	4.321		
Middle	5580	1	3.731		
		2	4.155		
High	5700	1	4.068		
		2	4.560		
Channel 144	5720	1	2.881		
		2	4.449		

Note: 1.PSD=Meas. Level+ Correction Factor
2. About correction Factor please refer to section 7.1

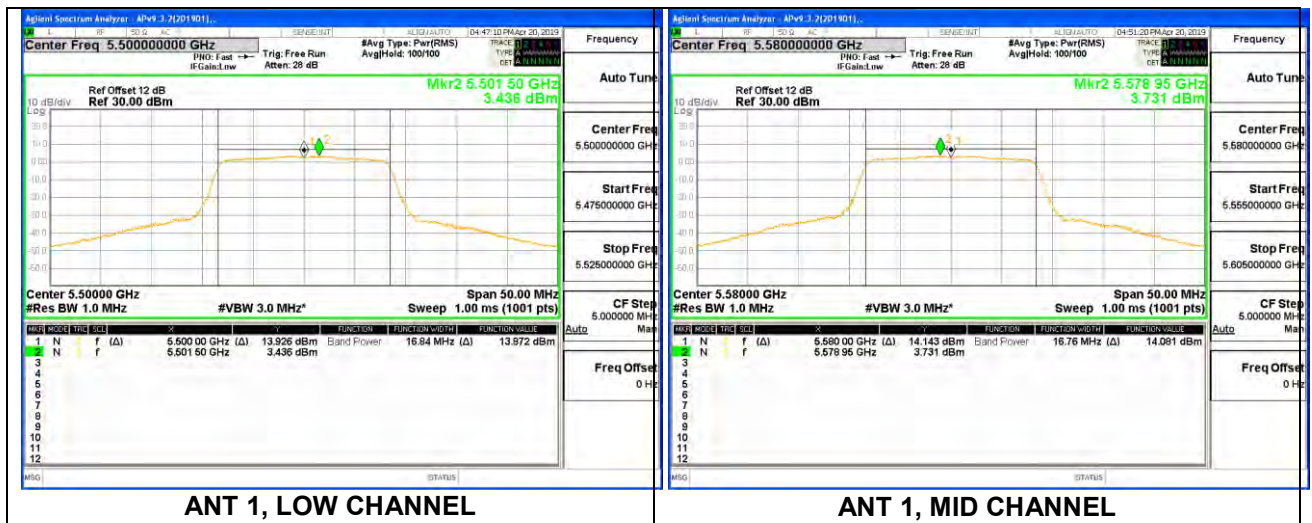

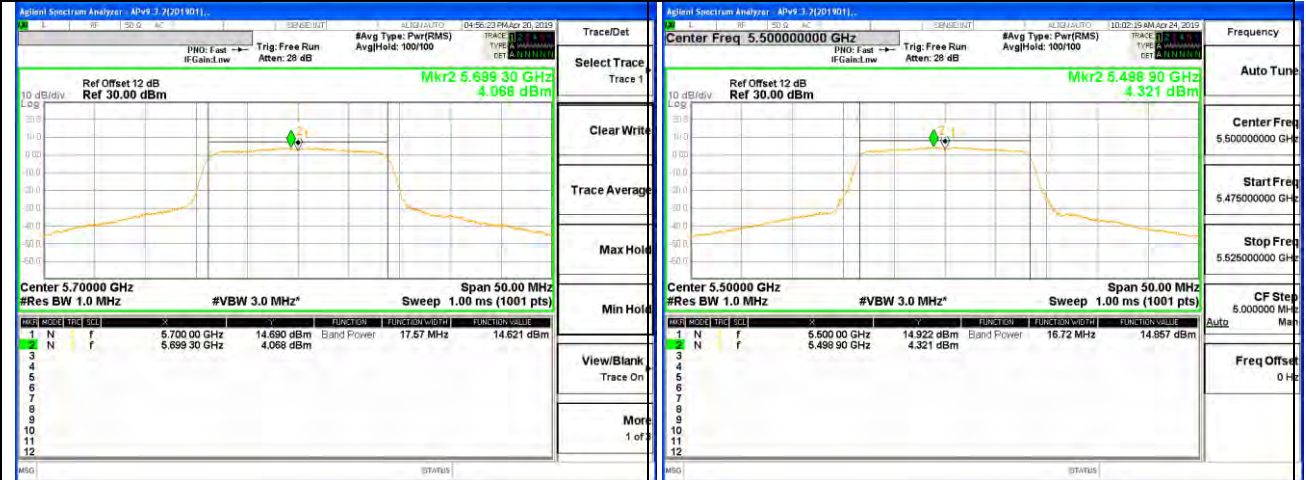

ANT 1, HIGH CHANNEL

ANT 2, LOW CHANNEL

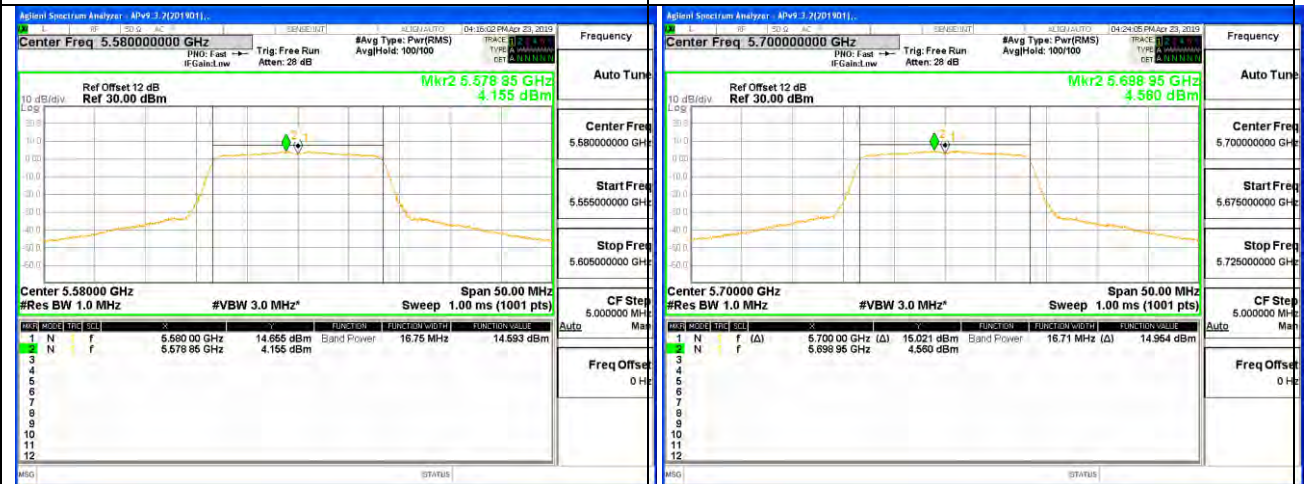

ANT 2, MID CHANNEL

ANT 2, HIGH CHANNEL

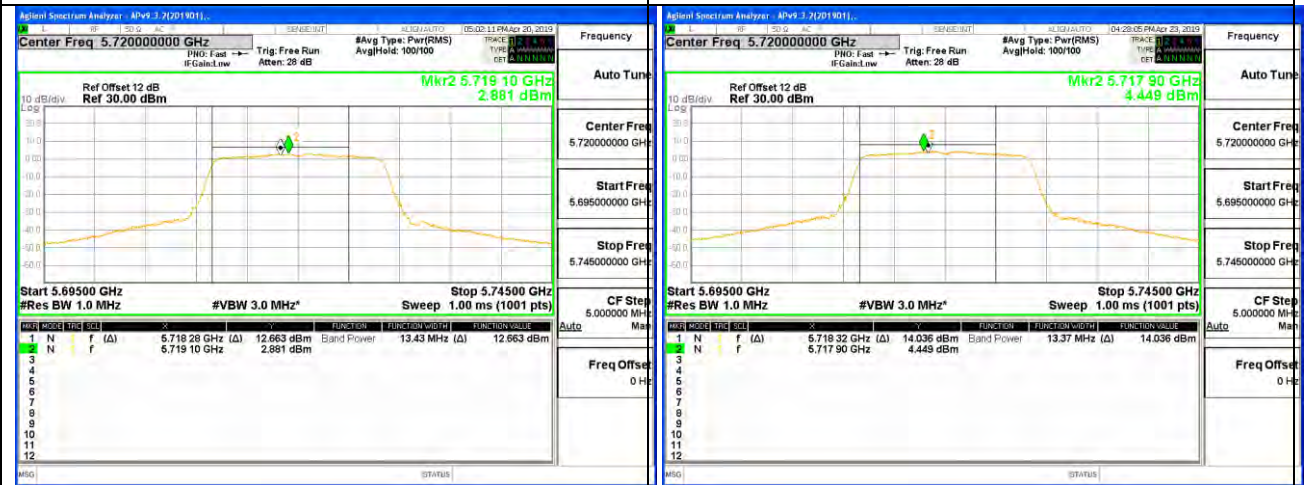

ANT 1, CHANNEL 144

ANT 2, CHANNEL 144



UNII-3 BAND

Test Channel	Frequency (MHz)	ANT	Meas. Level (dBm/500KHz)		Limit (dBm/500KHz)
			Single	Total	
Low	5745	1	1.913	N/A	30
		2	1.683		
Middle	5785	1	1.598		
		2	1.056		
High	5825	1	1.033		
		2	1.126		
Channel 144	5720	1	-1.192		
		2	0.047		

Note: 1. PSD=Meas. Level+ Correction Factor
2. About correction Factor please refer to section 7.1

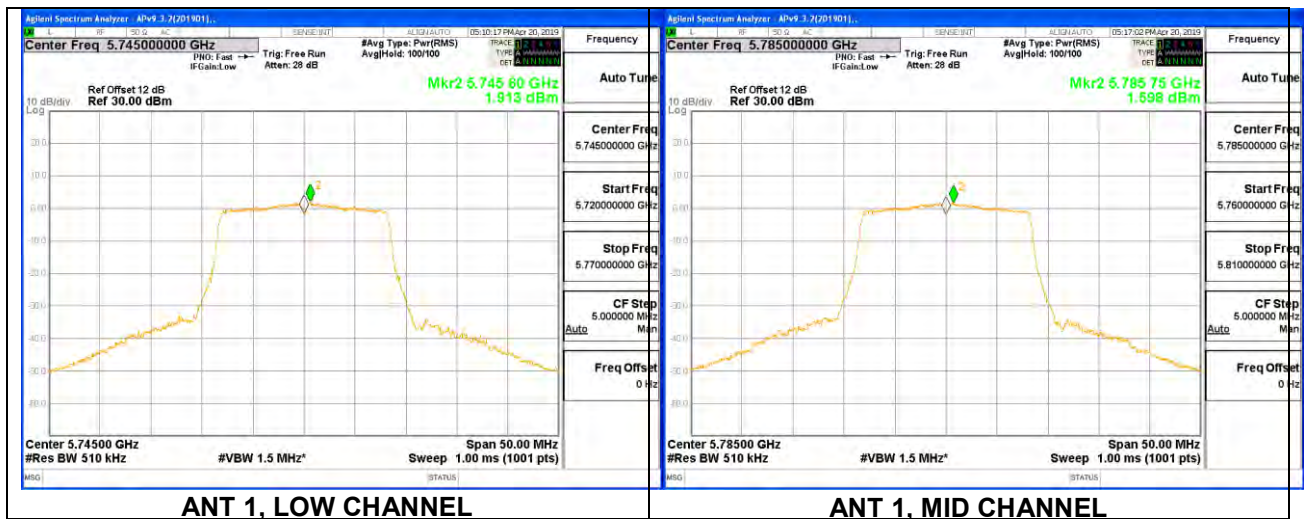

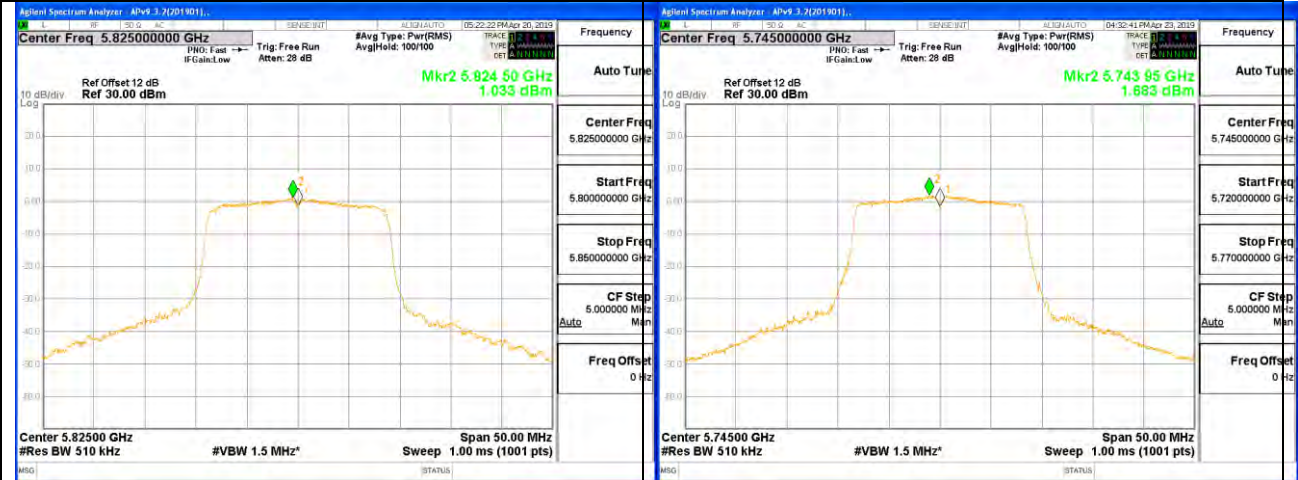

ANT 1, HIGH CHANNEL

ANT 2, LOW CHANNEL

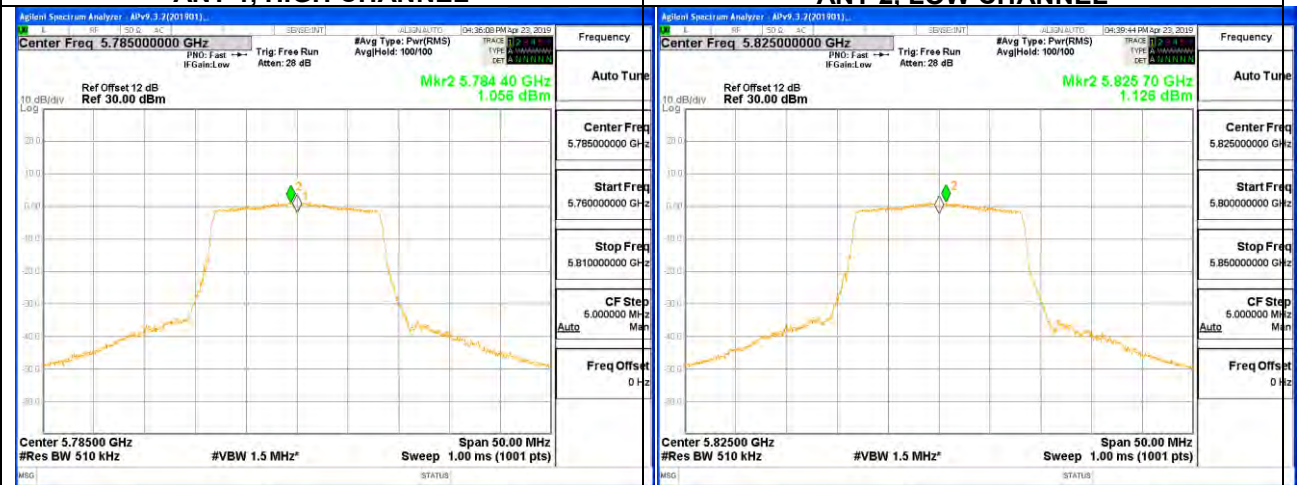

ANT 2, MID CHANNEL

ANT 2, HIGH CHANNEL

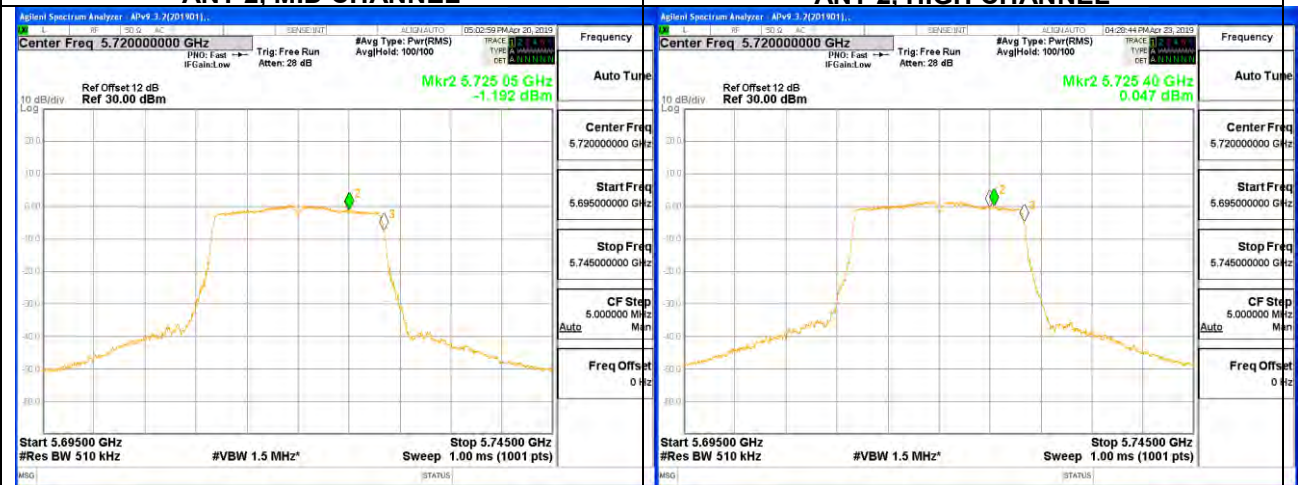

ANT 1, CHANNEL 144

ANT 2, CHANNEL 144



7.4.2. 802.11n HT20 CDD MODE

UNII-1 BAND

Test Channel	Frequency (MHz)	ANT	Meas. Level (dBm/MHz)		Limit (dBm/MHz)
			Single	Total	
Low	5180	1	2.582	5.33	11
		2	2.047		
Middle	5200	1	2.552	5.29	
		2	1.990		
High	5240	1	2.641	5.61	
		2	2.567		

- Note: 1.PSD=Meas. Level+ Correction Factor
2. About correction Factor please refer to section 7.1

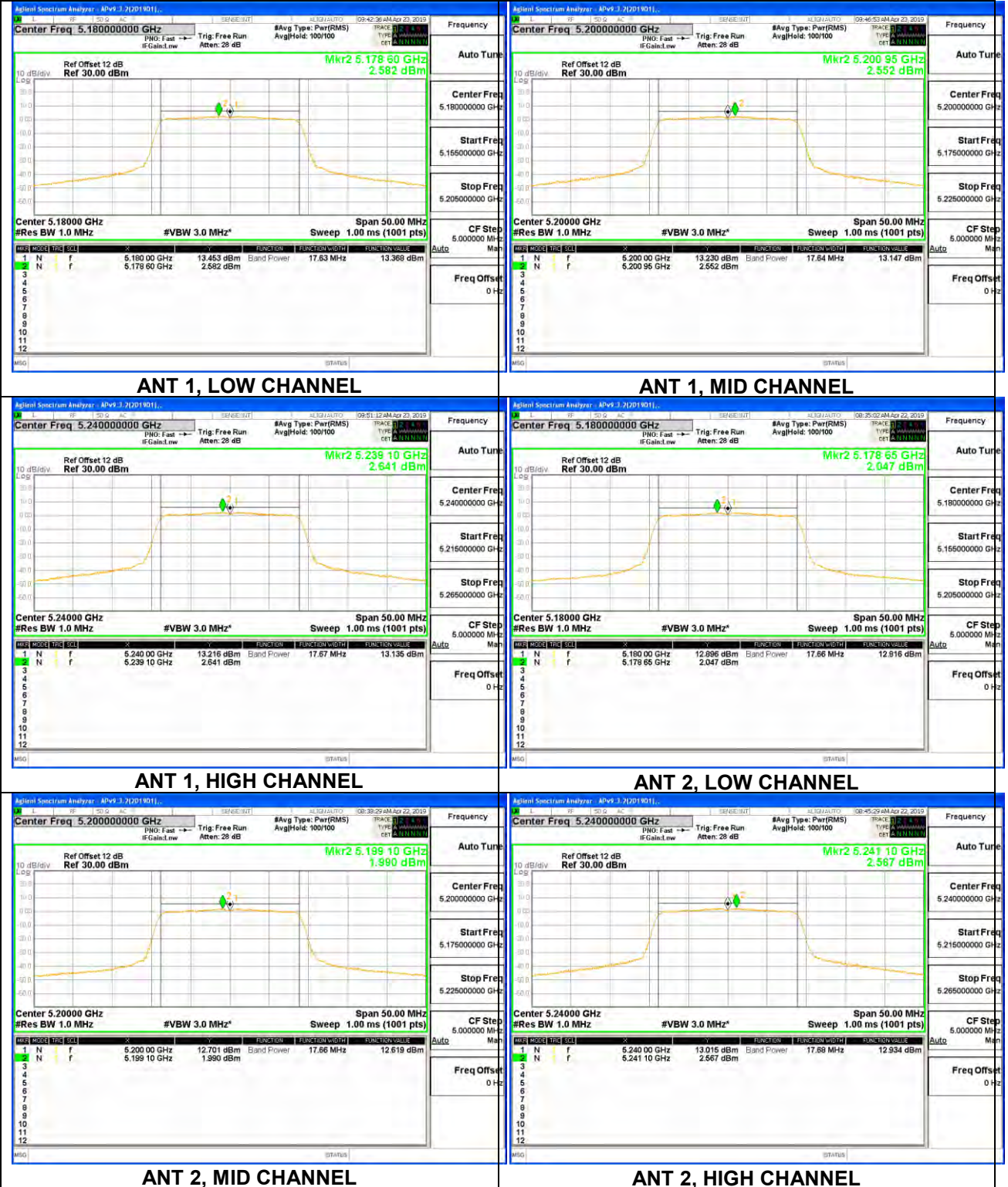



UNII-2A BAND

Test Channel	Frequency (MHz)	ANT	Meas. Level (dBm/MHz)		Limit (dBm/MHz)
			Single	Total	
Low	5260	1	3.136	5.46	11
		2	1.632		
Middle	5300	1	2.844	5.85	
		2	2.831		
High	5320	1	3.245	6.25	
		2	3.225		

- Note: 1.PSD=Meas. Level+ Correction Factor
2. About correction Factor please refer to section 7.1

