

保密等级：机密

SPECIFICATION

产品规格书

SKI.WB7638U.1_MT7638BU

IEEE 802.11a/b/g/n 2T2R USB Wi-Fi Module

Approved by Shikun		
Checked by 审核	Rechecked by 复审	Approved by 批准

Please send the original back to us after you have approved and signed.

客户承认签章后敬请寄回正本一份。

Approved by customer		
Comments 确认意见	Approved by 批准签字	Company's seal 盖章
Customer's Name:		

REVISION HISTORY

VERSION	DATE	BOARD ID	PAGE	DESCRIPTION	AUTHOR
V0	2019.10.29	SKI.WB7638U.1 _MT7638BU B19104	All	First Issued.	Yve
V1	2019.11.20	SKI.WB7638U.1 _MT7638BU B19104	5	Modified Electrical Characteristics.	Yve

Content

1. Introduction (简介)	1
2. FEATURES (特性)	1
3. Block Diagram (结构框图)	2
4. Package Outline and Mounting (外形及安装尺寸)	2
5. Pin Definition (引脚定义)	3
6. Product Pictures (实物图片)	4
7. Key Materials (关键物料)	4
8. General Requirements (一般要求)	4
9. Electrical Characteristics (电气特性)	5
9.1 IEEE 802.11b Section	5
9.2 IEEE 802.11g Section	6
9.3 IEEE 802.11n HT20 Section(2.4GHz)	6
9.4 IEEE 802.11n HT40 Section(2.4GHz)	7
9.5 IEEE 802.11a Section	8
9.6 IEEE 802.11n HT20 Section(5GHz)	9
9.7 IEEE 802.11n HT40 Section(5GHz)	10
10. Mechanical,Environmental and Reliability Tests (机械、环境和可靠性测试)	11
11. Package (包装)	13
12. Software Requirements (软件要求)	14

1. Introduction (简介)

SKI.WB7638U.1_MT7638BU module is based on MEDIATEK MT7638BUN solution. MT7638B is a highly integrated single chip which features a low power 2x2 11a/b/g/n dual-band Wi-Fi subsystem and a Bluetooth subsystem. The Wi-Fi subsystem contains the 802.11a/b/g/n radio, baseband, and MAC that are designed to meet both the low power and high throughput application. This documentation describes the engineering requirements specification.

SKI.WB7638U.1_MT7638BU 模块基于 MEDIATEK MT7638BUN 解决方案。MT7638B 是一款高度集成的芯片，具有低功耗 2x2 11a/b/g/n 双频 Wi-Fi 子系统和蓝牙子系统。Wi-Fi 子系统包含 802.11a/b/g/n 射频、基带和 MAC，旨在满足低功耗和高吞吐量应用。本文件描述了工程需求规范。

2. FEATURES (特性)

Reserving System 接收制式	IEEE Std. 802.11a
	IEEE Std. 802.11b
	IEEE Std. 802.11g
	IEEE Std. 802.11n
Chip Solution 芯片方案	MT7638BUN
Band 波段	2.4/5GHz
Dimensions 尺寸	32.0mm×22.0mm×3.0mm

Type 型号	Mounting Method 安装方式	Protocol 支持标准	Frequency 频段	ANT Interface 天线接口	Remarks 备注
SKI.WB7638U .1_MT7638BU	SMD	IEEE 802.11a/b/g/n	2.4/5GHz	IPEX	32.0mm×22.0mm ×3.0mm

3. Block Diagram (结构框图)

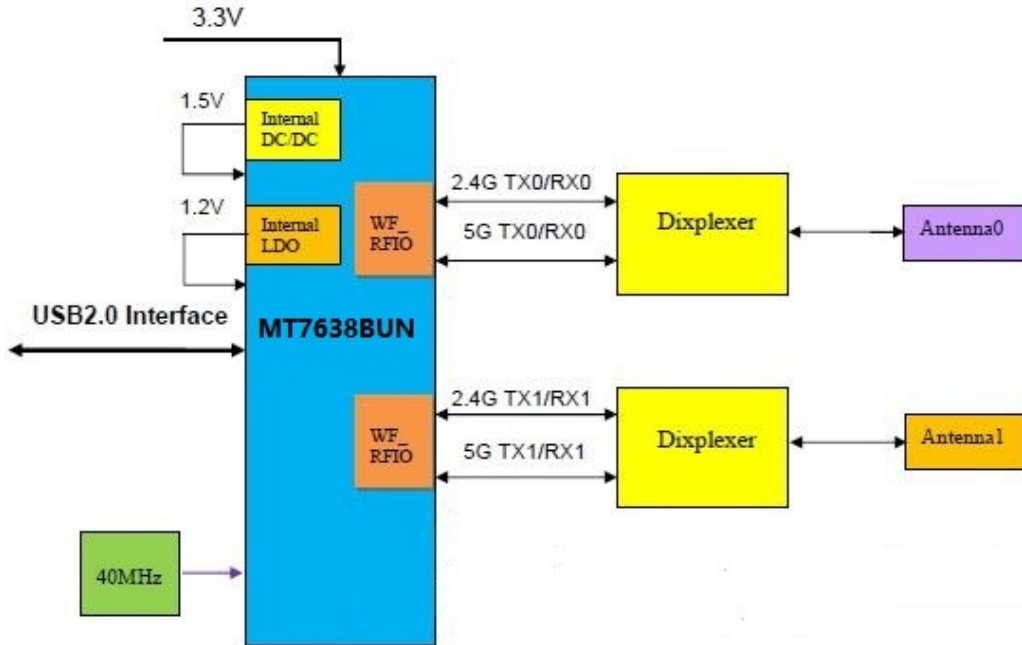
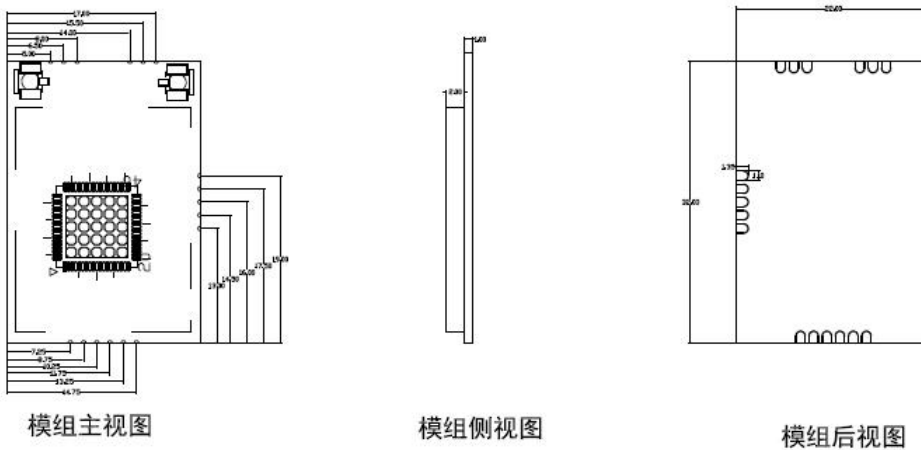

Figure 3.1 SKI.WB7638U.1_MT7638BU Block Diagram

4. Package Outline and Mounting (外形及安装尺寸)



注意：1单位为mm
2模组外形尺寸公差为0.2mm，板厚以及未标注公差为0.1mm

5. Pin Definition (引脚定义)

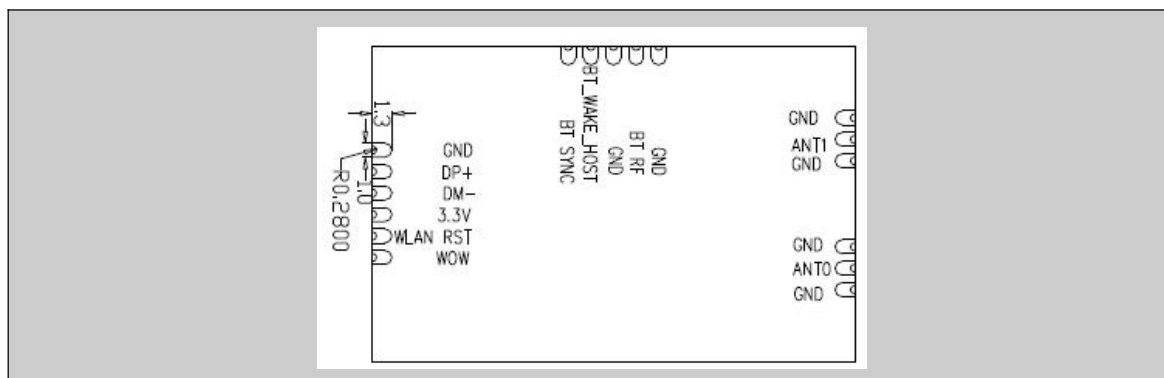

PIN	SYMBOL	DESCRIPTION
1	WOW	WIFI WAKE HOST \ WIFI 唤醒主机, 模组 4.7Kohm 上拉到 3.3V, 唤醒时模组输出低电平
2	WLAN RST	WLAN RST \ WLAN 复位, 模组 10Kohm 上拉到 3.3V, 低电平触发模组复位
3	VDD_3.3V	3.3V input \ 3.3V 输入
4	USB_DM	USB2.0 DM Signal \ USB2.0 差分负电压信号
5	USB_DP	USB2.0 DP Signal \ USB2.0 差分正电压信号
6	GND	Ground\地
7	BT SYNC	Frame sync signals from TV to sync with 3D glass via Bluetooth\3D 帧同步信号
8	NC	NC
9	GND	Ground\地
10	NC	NC
11	GND	Ground\地
12	GND	Ground\地
13	WL_RF1	Wi-Fi RF port1, connect to external antenna\Wi-Fi 射频端口 1, 连接外置天线
14	GND	Ground\地
15	GND	Ground\地
16	WL_RF0	Wi-Fi RF port0, connect to external antenna\Wi-Fi 射频端口 0, 连接外置天线
17	GND	Ground\地

6. Product Pictures (实物图片)



正视图 (top view)

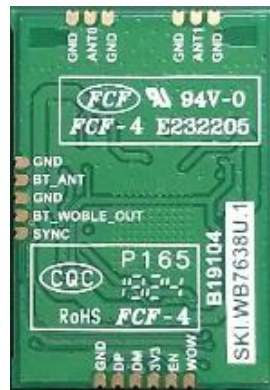

背视图 (bottom view)

7. Key Materials (关键物料)

序号	关键件名称	型号	规格/材料	备注
1	集成电路	MT7638BUN	76-QFN	--
2	PCB	SKI.WB7638U.1	FR-4,4LAY	--
3	晶体振荡器	2.3.3.400001535	40MHz	--
4	双工器	SLFD18-2R450G-13T	--	--

8. General Requirements (一般要求)

No.	Feature	Description
8-1	Operation Voltage 工作电压范围	3.3V+/-0.3
8-2	Current Consumption 最大电流	700mA
8-3	Ripple 纹波	≤100mV
8-4	Operation Temperature 工作温度范围	0°C to +40°C
8-5	Antenna Type 天线类型	External antenna
8-6	USB	High Speed USB 2.0 Interface
8-7	Storage Temperature 存储温度	-40°C to +85°C

9. Electrical Characteristics (电气特性)

除非另有说明，电气规范试验是在下列条件下进行，环境条件温度：25℃±5℃；电源电压：模块输入电压 3.3V (±10%)：

The Test for electrical specification was performed under the following condition unless otherwise specified.

Ambient condition Temperature :25℃ ± 5℃;

Power supply voltages: 3.3V (±10%) input power at the Module.

9.1 IEEE 802.11b Section

Items	Contents				
Specification	IEEE802.11b				
Mode	CCK				
Channel	CH1 to CH13				
Data rate	1, 2, 5.5, 11Mbps				
TX Characteristics	Min.	Typ.	Max.	Unit	Remark
1. Power Levels(Calibrated)					
1) For Each antenna port	15	17	19	dBm	
2. Spectrum Mask @ target power					
1) fc +/-11MHz to +/-22MHz	-	-	-30	dBr	
2) fc > +/-22MHz	-	-	-50	dBr	
3 Constellation Error(EVM)@ target power					
1) 1Mbps	-	-	-10	dB	
2) 2Mbps	-	-	-10	dB	
3) 5.5Mbps	-	-	-10	dB	
4) 11Mbps	-	-	-10	dB	
4. Frequency Error	-25	-	25	ppm	
RX Characteristics	Min.	Typ.	Max.	Unit	
5 Minimum Input Level Sensitivity (each chain)					
1) 1Mbps (FER ≤8%)	-	-	-83	dBm	
2) 2Mbps (FER ≤8%)	-	-	-80	dBm	
3) 5.5Mbps (FER ≤8%)	-	-	-79	dBm	
4) 11Mbps (FER ≤8%)	-	-	-76	dBm	
6 Maximum Input Level (FER ≤8%)	-10	-	-	dBm	

9.2 IEEE 802.11g Section

Items	Contents				
Specification	IEEE802.11g				
Mode	OFDM				
Channel	CH1 to CH13				
Data rate	6, 9, 12, 18, 24, 36, 48, 54Mbps				
TX Characteristics	Min.	Typ.	Max.	Unit	Remark
1. Power Levels					
1) For Each antenna port	13	15	17	dBm	
2. Spectrum Mask @ target power					
1) at fc +/-11MHz	-	-	-20	dB	
2) at fc +/-20MHz	-	-	-28	dB	
3) at fc > +/-30MHz	-	-	-40	dB	
3 Constellation Error(EVM)@ target power					
1) 6Mbps	-	-	-5	dB	
2) 9Mbps	-	-	-8	dB	
3) 12Mbps	-	-	-10	dB	
4) 18Mbps	-	-	-13	dB	
5) 24Mbps	-	-	-16	dB	
6) 36Mbps	-	-	-19	dB	
7) 48Mbps	-	-	-22	dB	
8) 54Mbps	-	-	-25	dB	
4 Frequency Error	-25	-	25	ppm	
RX Characteristics	Min.	Typ.	Max.	Unit	
5 Minimum Input Level Sensitivity (each chain)					
1) 6Mbps (PER ≤10%)	-	-	-85	dBm	
2) 9Mbps (PER ≤10%)	-	-	-84	dBm	
3) 12Mbps (PER ≤10%)	-	-	-82	dBm	
4) 18Mbps (PER ≤10%)	-	-	-80	dBm	
5) 24Mbps (PER ≤10%)	-	-	-77	dBm	
6) 36Mbps (PER ≤10%)	-	-	-73	dBm	
7) 48Mbps (PER ≤10%)	-	-	-69	dBm	
8) 54Mbps (PER ≤10%)	-	-	-65	dBm	
6 Maximum Input Level (PER ≤10%)	-20	-	-	dBm	

9.3 IEEE 802.11n HT20 Section(2.4GHz)

Items	Contents
Specification	IEEE802.11n HT20 @ 2.4GHz
Mode	OFDM

Channel	CH1 to CH13				
Data rate (MCS index)	MCS0/1/2/3/4/5/6/7				
TX Characteristics	Min.	Typ.	Max.	Unit	
2. Power Levels					
1) For Each antenna port	12	14	16	dBm	
3. Spectrum Mask @ target power					
1) at fc +/-11MHz	-	-	-20	dB	
2) at fc +/-20MHz	-	-	-28	dB	
3) at fc > +/-30MHz	-	-	-45	dB	
4. Constellation Error(EVM)@ target power					
1) MCS0	-	-	-5	dB	
2) MCS1	-	-	-10	dB	
3) MCS2	-	-	-13	dB	
4) MCS3	-	-	-16	dB	
5) MCS4	-	-	-19	dB	
6) MCS5	-	-	-22	dB	
7) MCS6	-	-	-25	dB	
8) MCS7	-	-	-28	dB	
5. Frequency Error	-25	-	25	ppm	
RX Characteristics	Min.	Typ.	Max.	Unit	
6. Minimum Input Level Sensitivity (each chain)					
1) MCS0 (PER ≤10%)	-	-	-82	dBm	
2) MCS1 (PER ≤10%)	-	-	-79	dBm	
3) MCS2 (PER ≤10%)	-	-	-77	dBm	
4) MCS3 (PER ≤10%)	-	-	-74	dBm	
5) MCS4 (PER ≤10%)	-	-	-70	dBm	
6) MCS5 (PER ≤10%)	-	-	-66	dBm	
7) MCS6 (PER ≤10%)	-	-	-65	dBm	
8) MCS7 (PER ≤10%)	-	-	-64	dBm	
7. Maximum Input Level (PER ≤10%)	-20	-	-	dBm	

9.4 IEEE 802.11n HT40 Section(2.4GHz)

Items	Contents				
Specification	IEEE802.11n HT40 @ 2.4GHz				
Mode	OFDM				
Channel	CH3 to CH11				
Data rate (MCS index)	MCS0/1/2/3/4/5/6/7				
	Min.	Typ.	Max.	Unit	Remark
TX Characteristics	Min.	Typ.	Max.	Unit	
1. Power Levels (Calibrated)					
1) For Each antenna port	12	14	16	dBm	

2. Spectrum Mask @target power					
1) at fc +/-22MHz	-	-	-20	dBr	
2) at fc +/-40MHz	-	-	-28	dBr	
3) at fc > +/-60MHz	-	-	-45	dBr	
3. Constellation Error(EVM)@ target power					
1) MCS0	-	-	-5	dB	
2) MCS1	-	-	-10	dB	
3) MCS2	-	-	-13	dB	
4) MCS3	-	-	-16	dB	
5) MCS4	-	-	-19	dB	
6) MCS5	-	-	-22	dB	
7) MCS6	-	-	-25	dB	
8) MCS7	-	-	-28	dB	
4. Frequency Error	-25	-	25	ppm	
RX Characteristics	Min.	Typ.	Max.	Unit	
5. Minimum Input Level Sensitivity (each chain)					
1) MCS0 (PER ≤10%)	-	-	-79	dBm	
2) MCS1 (PER ≤10%)	-	-	-76	dBm	
3) MCS2 (PER ≤10%)	-	-	-74	dBm	
4) MCS3 (PER ≤10%)	-	-	-71	dBm	
5) MCS4 (PER ≤10%)	-	-	-67	dBm	
6) MCS5 (PER ≤10%)	-	-	-63	dBm	
7) MCS6 (PER ≤10%)	-	-	-62	dBm	
8) MCS7 (PER ≤10%)	-	-	-61	dBm	
6. Maximum Input Level (PER ≤10%)	-20	-	-	dBm	

9.5 IEEE 802.11a Section

Items	Contents				
Specification	IEEE802.11a				
Mode	OFDM				
Channel	CH36 to CH165				
Data rate	6, 9, 12, 18, 24, 36, 48, 54Mbps				
TX Characteristics	Min.	Typ.	Max.	Unit	Remark
1. Power Levels					
1) For Each antenna port	12	14	16	dBm	
2. Spectrum Mask @ target power					
1) at fc +/-11MHz	-	-	-20	dBr	
2) at fc +/-20MHz	-	-	-28	dBr	
3) at fc > +/-30MHz	-	-	-40	dBr	
3 Constellation Error(EVM)@ target power					
1) 6Mbps	-	-	-5	dB	

2) 9Mbps	-	-	-8	dB	
3) 12Mbps	-	-	-10	dB	
4) 18Mbps	-	-	-13	dB	
5) 24Mbps	-	-	-16	dB	
6) 36Mbps	-	-	-19	dB	
7) 48Mbps	-	-	-22	dB	
8) 54Mbps	-	-	-25	dB	
4 Frequency Error	-20	-	20	ppm	
RX Characteristics	Min.	Typ.	Max.	Unit	
5 Minimum Input Level Sensitivity (each chain)					
1) 6Mbps (PER $\leq 10\%$)	-	-	-82	dBm	
2) 9Mbps (PER $\leq 10\%$)	-	-	-81	dBm	
3) 12Mbps (PER $\leq 10\%$)	-	-	-79	dBm	
4) 18Mbps (PER $\leq 10\%$)	-	-	-77	dBm	
5) 24Mbps (PER $\leq 10\%$)	-	-	-74	dBm	
6) 36Mbps (PER $\leq 10\%$)	-	-	-70	dBm	
7) 48Mbps (PER $\leq 10\%$)	-	-	-66	dBm	
8) 54Mbps (PER $\leq 10\%$)	-	-	-65	dBm	
6 Maximum Input Level (PER $\leq 10\%$)	-30	-	-	dBm	

9.6 IEEE 802.11n HT20 Section(5GHz)

Items	Contents				
Specification	IEEE802.11n HT20 @ 5GHz				
Mode	BPSK, QPSK, 16QAM, 64QAM and OFDM				
Channel	CH36 to CH165				
Data rate (MCS index)	MCS0/1/2/3/4/5/6/7				
TX Characteristics	Min.	Typ.	Max.	Unit	
2. Power Levels					
1) For Each antenna port	11	13	15	dBm	
3. Spectrum Mask @ target power					
1) at fc +/-11MHz	-	-	-20	dBr	
2) at fc +/-20MHz	-	-	-28	dBr	
3) at fc > +/-30MHz	-	-	-45	dBr	
4. Constellation Error(EVM)@ target power					
1) MCS0	-	-	-5	dB	
2) MCS1	-	-	-10	dB	
3) MCS2	-	-	-13	dB	
4) MCS3	-	-	-16	dB	
5) MCS4	-	-	-19	dB	
6) MCS5	-	-	-22	dB	
7) MCS6	-	-	-25	dB	

8) MCS7	-	-	-28	dB	
5. Frequency Error	-20	-	20	ppm	
RX Characteristics	Min.	Typ.	Max.	Unit	
7. Minimum Input Level Sensitivity (each chain)					
1) MCS0 (PER $\leq 10\%$)	-	-	-82	dBm	
2) MCS1 (PER $\leq 10\%$)	-	-	-79	dBm	
3) MCS2 (PER $\leq 10\%$)	-	-	-77	dBm	
4) MCS3 (PER $\leq 10\%$)	-	-	-74	dBm	
5) MCS4 (PER $\leq 10\%$)	-	-	-70	dBm	
6) MCS5 (PER $\leq 10\%$)	-	-	-66	dBm	
7) MCS6 (PER $\leq 10\%$)	-	-	-65	dBm	
8) MCS7 (PER $\leq 10\%$)	-	-	-64	dBm	
7. Maximum Input Level (PER $\leq 10\%$)	-30	-	-	dBm	

9.7 IEEE 802.11n HT40 Section(5GHz)

Items	Contents				
Specification	IEEE802.11n HT40 @ 5GHz				
Mode	BPSK, QPSK, 16QAM, 64QAM and OFDM				
Channel	CH38 to CH163				
Data rate (MCS index)	MCS0/1/2/3/4/5/6/7				
	Min.	Typ.	Max.	Unit	Remark
TX Characteristics	Min.	Typ.	Max.	Unit	
1. Power Levels (Calibrated)					
1) For Each antenna port	11	13	15	dBm	
2. Spectrum Mask @target power					
1) at fc +/-21MHz	-	-	-20	dBr	
2) at fc +/-40MHz	-	-	-28	dBr	
3) at fc > +/-60MHz	-	-	-45	dBr	
3. Constellation Error(EVM)@ target power					
1) MCS0	-	-	-5	dB	
2) MCS1	-	-	-10	dB	
3) MCS2	-	-	-13	dB	
4) MCS3	-	-	-16	dB	
5) MCS4	-	-	-19	dB	
6) MCS5	-	-	-22	dB	
7) MCS6	-	-	-25	dB	
8) MCS7	-	-	-28	dB	
4. Frequency Error	-20	-	20	ppm	
RX Characteristics	Min.	Typ.	Max.	Unit	
6. Minimum Input Level Sensitivity (each chain)					

1) MCS0 (PER $\leq 10\%$)	-	-	-79	dBm	
2) MCS1 (PER $\leq 10\%$)	-	-	-76	dBm	
3) MCS2 (PER $\leq 10\%$)	-	-	-74	dBm	
4) MCS3 (PER $\leq 10\%$)	-	-	-71	dBm	
5) MCS4 (PER $\leq 10\%$)	-	-	-67	dBm	
6) MCS5 (PER $\leq 10\%$)	-	-	-63	dBm	
7) MCS6 (PER $\leq 10\%$)	-	-	-62	dBm	
8) MCS7 (PER $\leq 10\%$)	-	-	-61	dBm	
6. Maximum Input Level (PER $\leq 10\%$)	-30	-	-	dBm	

10. Mechanical, Environmental and Reliability Tests

(机械、环境和可靠性测试)

Test Items		Test Conditions	Qty	Criteria Condition
10-1	Drop test	The packed samples within 100Kg can be tested Drop height: Face Side: 800/600/450mm Edge line: 600/450/350mm Drop time: 1 each Face and edge.	1xBox	After drop test, the outer box and inner box will not be broken by appearance visual inspection.
10-2	Vibration test	X-Y-Z direction, first Frequency changing from 10Hz to 30Hz to 10Hz, amplitude 0.75mm, 5 times vibrations, then frequency Changing from 30Hz to 55 Hz to 30 Hz, amplitude 0.15mm, 5 time vibration.	3	After test, the Appearance, Power EVM and Frequency error shall be satisfied with the specification.
10-3	Impact test	Impact acceleration: 50m/sec ² ; Impact duration: 16ms; Impact times: 1000.	3	After test, the Appearance, Power EVM and Frequency error shall be satisfied with the specification.
10-4	Soldering ability test	Soldering temperature: 235 \pm 5 $^{\circ}$ C Soldering duration: 2 \pm 0.5S	3	1. After soldering, the soldered area must be covered by a smooth bright solder layer, some deficiencies such as a small amount of the pinhole, not wetting are allowed, but the deficiencies can not be in the same place; 2. At least 90% of soldered area shall be

				covered continuously by the soldering material.
10-5	Humidity test	Leave samples in 40±3℃, 93% RH @ 96 hours	3	Leave samples in standard test condition for 2 hours then test, the Appearance, Power, EVM and Frequency error functional parameter shall be satisfied with the test specification.
10-6	High temperature load life test	Thermostat cabinet temperature: 55±5℃ Applied voltage: 110% rated voltage Working duration: 200 hour (Supply Voltage Cycle 23h power on, 1h power off)	60	After test, leave samples in standard condition for 1 hour and test, Power, EVM and Frequency error shall be satisfied with the test specification.
10-7	High temperature load test	Temperature: 55±5℃ Samples work for 16 hours	3	After test, the Appearance, Power, EVM and Frequency error shall be Satisfied with the test specification.
10-8	Low temperature storage test	Leave the samples in -25±3℃@24 hours	3	Leave samples in standard test condition for 2 hours then test, the Appearance, Power, EVM and Frequency error shall be satisfied with the test specification.
10-9	Low temperature load test	Leave samples in -15±3℃@ 2 hours, samples' function shall be normal, the let samples work for 1 hour	3	After test, leave the samples in standard condition and tested the Appearance, Power, EVM and Frequency error shall be satisfied with the test specification.
10-10	Temperature circle test	One cycle duration -10±3℃@3H 40±3℃ @3H Total cycle: 10x	3	After test, leave the samples in standard condition and tested Power EVM and Frequency error shall be qualified and all the characters shall be satisfied with the test specification.
10-11	Continuous TP test	Twice cycle duration -10±3℃@4H +60±3℃@4H, +25@2H@2H	3	During test, There will not been appeared signal disconnection or interruption between DUT and AP.
10-12	ESD	Discharge voltage: 1kV C: 150pF Discharge resistance: 330Ω Positive10 times 1 time for each second	3	The products can recoverable smoothly after ESD test.

11. Package (包装)

(1) 编带尺寸:

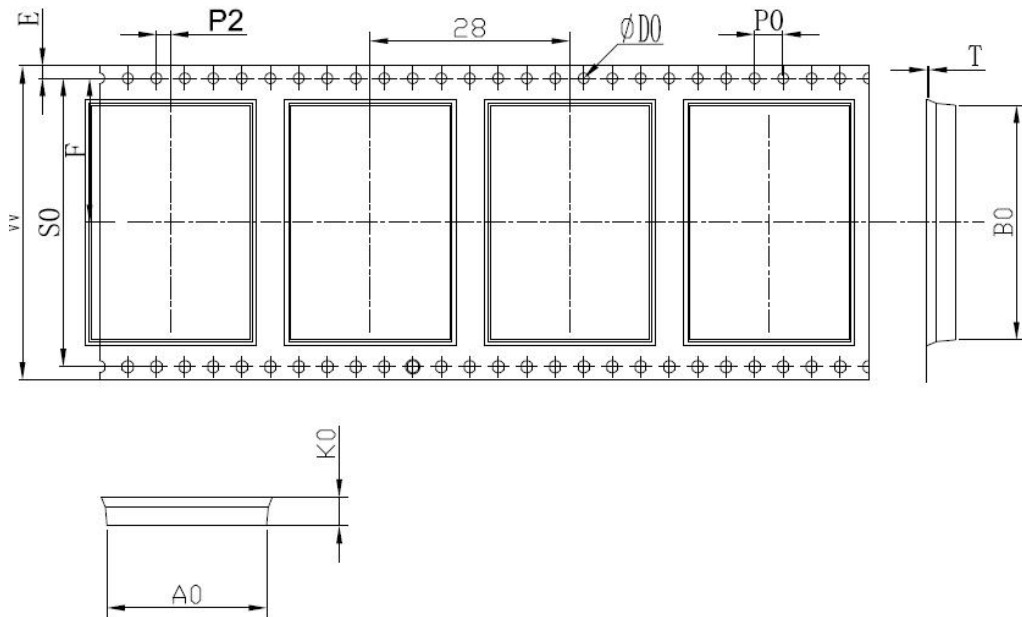

(2) 编带方向: (箭头代表编带走向)

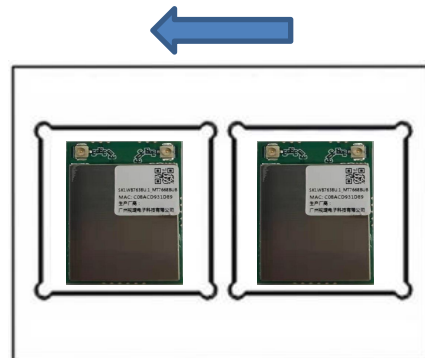
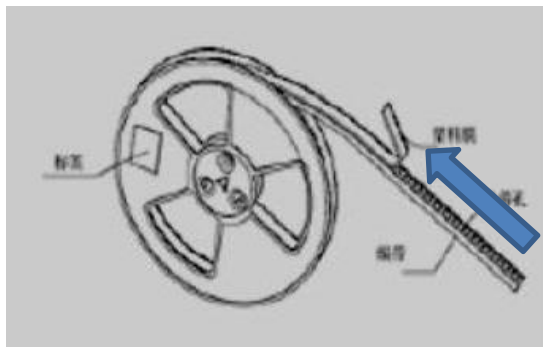

(3) 包装示意图:



注: 上图 3 个框示处为内盒标签粘贴位置。

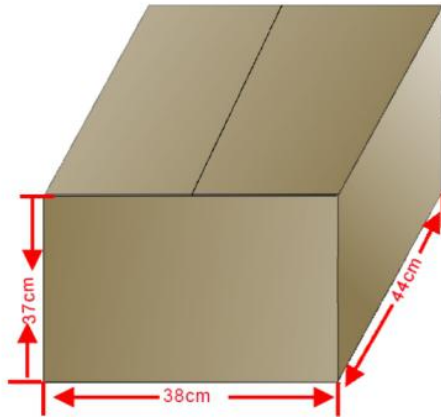

550pcs/盘*8 盘/箱=4400pcs/箱

(4) 标签样式:

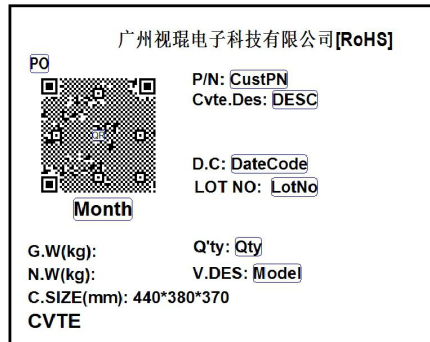

12. Software Requirements (软件要求)

The driver supports the following operating systems: Microsoft Windows XP, Vista and Win7.

驱动程序支持以下操作系统：微软 Windows XP, Vista 和 win7。

Installation Guidance

The final host / module combination may also need to be evaluated against the FCC Part 15B criteria for unintentional radiators in order to be properly authorized for operation as a Part 15 digital device.

The user's manual or instruction manual for an intentional or unintentional radiator shall caution the user that changes or modifications not expressly approved by the party responsible for compliance could void the user's authority to operate the equipment. In cases where the manual is provided only in a form other than paper, such as on a computer disk or over the Internet, the information required by this section may be included in the manual in that alternative form, provided the user can reasonably be expected to have the capability to access information in that form.

To ensure compliance with all non-transmitter functions the host manufacturer is responsible for ensuring compliance with the module(s) installed and fully operational. For example, if a host was previously authorized as an unintentional radiator under the Declaration of Conformity procedure without a transmitter certified module and a module is added, the host manufacturer is responsible for ensuring that after the module is installed and operational the host continues to be compliant with the Part 15B unintentional radiator requirements.

FCC Statement

This device complies with Part 15 of the FCC Rules. Operation is subject to the following two conditions:

(1) this device may not cause harmful interference, and (2) this device must accept any interference received, including interference that may cause undesired operation.

Caution: The user is cautioned that changes or modifications not expressly approved by the party responsible for compliance could void the user's authority to operate the equipment.

Note: This equipment has been tested and found to comply with the limits for a Class B digital device, pursuant to part 15 of the FCC Rules. These limits are designed to provide reasonable protection against harmful interference in a residential installation. This equipment generates uses and can radiate radio frequency energy and, if not installed and used in accordance with the instructions, may cause harmful interference to radio communications. However, there is no guarantee that interference will not occur in a particular installation. If this equipment does cause harmful interference to radio or television reception, which can be determined by turning the equipment off and on, the user is encouraged to try to correct the interference by one or more of the following measures:

- Reorient or relocate the receiving antenna.
- Increase the separation between the equipment and receiver.
- Connect the equipment into an outlet on a circuit different from that to which the receiver is connected.
- Consult the dealer or an experienced radio/TV technician for help.

If power exceeds the limit and the distance (Over 20cm distance in actual use between the device and user) is compliant with the requirement

FCC RF Radiation Exposure Statement:

This equipment complies with FCC radiation exposure limits set forth for an uncontrolled environment. This equipment should be installed and operated with a minimum distance of 20cm between the radiator and any part of your body.

The device must be professionally installed

The intended use is generally not for the general public. It is generally for industry/commercial use.

The connector is within the transmitter enclosure and can only be accessed by disassembly of the transmitter that is not normally required. The user has no access to the connector.

Installation must be controlled. Installation requires special training

Canada Statement

This device contains licence-exempt transmitter(s)/receiver(s) that comply with Innovation, Science and Economic Development Canada's licence-exempt RSS(s). Operation is subject to the following two conditions:

(1) This device may not cause interference.

(2) This device must accept any interference, including interference that may cause undesired operation of the device.

L'émetteur/récepteur exempt de licence contenu dans le présent appareil est conforme aux CNR d'Innovation, Sciences et Développement économique Canada applicables aux appareils radio exempts de licence. L'exploitation est autorisée aux deux conditions suivantes :

1) L'appareil ne doit pas produire de brouillage;

2) L'appareil doit accepter tout brouillage radioélectrique subi, même si le brouillage est susceptible d'en compromettre le fonctionnement.

Please notice that if the ISED certification number is not visible when the module is installed inside another device, then the outside of the device into which the module is installed must also display a label referring to the enclosed module. This exterior label can use wording such as the following: “ Contains IC: 24728-SKIWB7638U1 ” any similar wording that expresses the same meaning may be used.

l'appareil hôte doit porter une étiquette donnant le numéro de certification du module d'Industrie Canada, précédé des mots « Contient un module d'émission », du mot « IC: 24728-SKIWB7638U1 » ou d'une formulation similaire exprimant le même sens, comme suit

The device meets the exemption from the routine evaluation limits in section 2.5 of RSS 102 and compliance with RSS-102 RF exposure, users can obtain Canadian information on RF exposure and compliance.

Le dispositif rencontre l'exemption des limites courantes d'évaluation dans la section 2.5 de RSS 102 et la conformité à l'exposition de RSS-102 rf, utilisateurs peut obtenir l'information canadienne sur l'exposition et la conformité de rf.

This transmitter must not be co-located or operating in conjunction with any other antenna or transmitter. This equipment should be installed and operated with a minimum distance of 20 centimeters between the radiator and your body.

Cet émetteur ne doit pas être Co-placé ou ne fonctionnant en même temps qu'aucune autre antenne ou émetteur. Cet équipement devrait être installé et actionné avec une distance minimum de 20 centimètres entre le radiateur et votre corps.

This radio transmitter 24728-SKIWB7638U1 has been approved by Innovation, Science and Economic Development Canada to operate with the antenna types listed below, with the maximum permissible gain indicated. Antenna types not included in this list that have a gain greater than the maximum gain indicated for any type listed are strictly prohibited for use with this device.

Le présent émetteur radio 24728-SKIWB7638U1 a été approuvé par Innovation, Sciences et Développement économique Canada pour fonctionner avec les types d'antenne énumérés ci-dessous et ayant un gain admissible maximal. Les types d'antenne non inclus dans cette liste, et dont le gain est supérieur au gain maximal indiqué pour tout type figurant sur la liste, sont strictement interdits pour l'exploitation de l'émetteur.

The concrete contents to check are the following three points.

- 1) Must use a PIFA antenna such as WA-M-LB-02-164 with gain not exceeding 1.5 dBi
- 2) Should be installed so that the end user cannot modify the antenna;
- 3) Feed line should be designed in 50ohm

Fine tuning of return loss etc. can be performed using a matching network.

Le contenu concret à vérifier sont les trois points suivants.

- 1) doit utiliser une antenne comme WA-M-LB-02-164 avec pifa gain n'excédant pas 1.5 dBi
- 2) doivent être installés de façon que l'utilisateur final ne peut pas modifier l'antenne
- 3) La ligne d'alimentation doit être conçue en 50ohm

Le réglage précis de la perte de rendement, etc. peut être effectué en utilisant un réseau correspondant.

Frequency (MHz) fréquences	Antenna Type types d'antenne	Antenna Gain (dBi) Gain maximal d'antenne
2412-2472	PIFA Antenna	1.5
5180-5825	PIFA Antenna	1.5

Notice to OEM integrator

Must use the device only in host devices that meet the FCC/ISED RF exposure category of mobile, which means the device is installed and used at distances of at least 20cm from persons.

The end user manual shall include FCC Part 15 /ISED RSS GEN compliance statements related to the transmitter as show in this manual.

Host manufacturer is responsible for compliance of the host system with module installed with all other applicable requirements for the system such as Part 15 B, ICES 003.

Host manufacturer is strongly recommended to confirm compliance with FCC/ISED requirements for the transmitter when the module is installed in the host.

Must have on the host device a label showing Contains FCC ID: 2AR82-SKIWB7638U1, IC: 24728-SKIWB7638U1

l'hôte doit utiliser l'instrument uniquement dans des dispositifs qui répondent à la fcc / (catégorie d'exposition rf mobile, ce qui signifie le dispositif est installé et utilisé à une distance d'au moins 20 cm de personnes.

le manuel de l'utilisateur final doit inclure la partie 15 / (fac rss gen déclarations de conformité relatives à l'émetteur que de montrer dans ce manuel.

le fabricant est responsable de la conformité de l'hôte, le système d'accueil avec le module installé avec toutes les autres exigences applicables du système comme la partie 15 b, ices - 003.

accueillir le fabricant est fortement recommandé de confirmer la conformité avec les exigences de la fcc / (émetteur lorsque le module est installé dans l'hôte.

le dispositif d'accueil doivent avoir une étiquette indiquant contient FCC ID: 2AR82-SKIWB7638U1, IC: 24728-SKIWB7638U1
