



Test report No:
2380793R-RF-US-P06V01

FCC TEST REPORT

Product Name	IEEE 802.11a/b/g/n/ac 2T2R USB Wi-Fi Module Integrated Bluetooth 2.1+EDR/4.2/5.1
Model and /or type reference	SKI.WB663U.2
FCC ID	2AR82-SKIWB663U21
IC	24728-SKIWB663U21
Applicant's name / address	Guangzhou Shikun Electronics Co., Ltd NO.6 Liankun Road, Huangpu District, Guangzhou 510530, China
Test method requested, standard	47 CFR FCC Part 15 (Section 15.247) RSS-Gen Issue5 RSS-247 Issue2
Verdict Summary	IN COMPLIANCE
Tested by (name / position & signature)	Tim Cao/Project Manager <i>Tim Cao</i>
Approved by (name / position & signature)	Jack Zhang/ Manager <i>Jack Zhang</i>
Date of issue	2023-09-26
Report Version	V1.0
Report template No	Template_FCC 15.247-RF-V1.0

INDEX

	page
General conditions.....	4
Environmental conditions	4
Possible test case verdicts	5
Abbreviations.....	5
Document History	6
Remarks and Comments.....	6
Used Equipment.....	7
Uncertainty	9
1 General Information.....	10
1.1 General Description of the Item(s)	10
1.2 Antenna Information	11
1.3 Channel List	12
2 Description of Test Setup	13
2.1 Operating mode(s) used for tests.....	13
2.2 Auxiliary equipment /Accessories/Test software for the EUT	13
2.3 Test Configuration / Block diagram used for tests	14
2.4 Testing process.....	15
3 Verdict summary section	16
3.1 Standards.....	16
3.2 Deviation(s) from the Standard(s) / Test Specification(s)	16
3.3 Overview of results.....	17
3.4 Power setting in test.....	17
3.5 Test Matrix.....	18
3.6 Test Facility	19
4 Test Items of limit/setup/procedure	20
4.1 Maximum conducted output power	20
4.1.1 Limit	20
4.1.2 Test Setup.....	20
4.1.3 Test Procedure	21
4.2 Band edge measurements	22
4.2.1 Limit.....	22
4.2.2 Test Setup.....	22
4.2.3 Test Procedure.....	22
4.3 Emissions in Restricted Bands.....	23

4.3.1	Limit.....	23
4.3.2	Test Setup.....	25
4.3.3	Test Procedure.....	26
4.4	Antenna Requirement	27
4.4.1	Limit.....	27
4.4.2	Antenna Connector Construction:.....	27
5	Test setup photo and EUT Photo	27
6	Test Result	28
	Appendix A: RF Output Power	28
	Appendix B: Band edge measurements.....	29
	Appendix C: Emissions in Restricted Bands	53

COMPETENCES AND GUARANTEES

DEKRA is a testing laboratory competent to carry out the tests described in this report.

In order to assure the traceability to other national and international laboratories, DEKRA has a calibration and maintenance program for its measurement equipment.

DEKRA guarantees the reliability of the data presented in this report, which is the result of the measurements and the tests performed to the item under test on the date and under the conditions stated in the report and it is based on the knowledge and technical facilities available at DEKRA at the time of performance of the test.

DEKRA is liable to the client for the maintenance of the confidentiality of all information related to the item under test and the results of the test.

The results presented in this Test Report apply only to the particular item under test established in this document.

IMPORTANT:No parts of this report may be reproduced or quoted out of context, in any form or by any means, except in full, without the previous written permission of DEKRA.

GENERAL CONDITIONS

Test Location	No. 99, Hongye Road, Suzhou Industrial Park Suzhou, 215006, P.R. China
Date(receive sample)	Aug. 24, 2023
Date (start test)	Sept. 14, 2023
Date (finish test)	Sept. 21, 2023

1. This report is only referred to the item that has undergone the test.
2. This report does not constitute or imply on its own an approval of the product by the Certification Bodies or Competent Authorities.
3. This document is only valid if complete; no partial reproduction can be made without previous written permission of DEKRA.
4. This test report cannot be used partially or in full for publicity and/or promotional purposes without previous written permission of DEKRA.

ENVIRONMENTAL CONDITIONS

The climatic conditions during the tests are within the limits specified by the manufacturer for the operation of the EUT and the test equipment. The climatic conditions during the tests were within the following limits:

Ambient temperature	15 °C – 35 °C
Relative Humidity air	30% - 60%

If explicitly required in the basic standard or applied product / product family standard the climatic values are recorded and documented separately in this test report.

POSSIBLE TEST CASE VERDICTS

Test case does not apply to test object	N/A
Test object does meet requirement	P (Pass) / PASS
Test object does not meet requirement	F (Fail) / FAIL
Not measured	N/M

ABBREVIATIONS

For the purposes of the present document, the following abbreviations apply:

EUT	: Equipment Under Test
QP	: Quasi-Peak
CAV	: CISPR Average
AV	: Average
CDN	: Coupling Decoupling Network
SAC	: Semi-Anechoic Chamber
OATS	: Open Area Test Site
BW	: Bandwidth
AM	: Amplitude Modulation
PM	: Pulse Modulation
HCP	: Horizontal Coupling Plane
VCP	: Vertical Coupling Plane
U_N	: Nominal voltage
T_x	: Transmitter
R_x	: Receiver
N/A	: Not Applicable
N/M	: Not Measured

DOCUMENT HISTORY

Report No.	Version	Description	Issued Date
2380793R-RF-US-P06V01	V1.0	Initial issue of report.	2023-09-26

REMARKS AND COMMENTS

1. The equipment under test (EUT) does meet the essential requirements of the stated standard(s)/test(s).
2. This report is based on the certified module with only the antenna added, so only radiated spurious emissions and radiated band edge tests have been performed to demonstrate compliance with the requirements of Part 15 Subpart C 15.247(RSS-Gen Issue5 and RSS-247 Issue2) and to meet the requirements of the Calss II permissible variations. The module certification report number is 4790010773.1-2.
3. The measurement result is considered in conformance with the requirement if it is within the prescribed limit, It is not necessary to account the uncertainty associated with the measurement result.
4. The test results presented in this report relate only to the object tested.
5. The test report shall not be reproduced without the written approval of DEKRA Testing and Certification (Suzhou) Co., Ltd.
6. This report will not be used for social proof function in China market.
7. DEKRA declines any responsibility with the following test data provided by customer that may affect the validity of result:
 - Chapter 1.1 General Description of the Item(s);
 - Chapter 1.2 Antenna Information ;
 - Chapter 1.3Channel List.

USED EQUIPMENT

Maximum Conducted Output Power / TR8

Instrument	Manufacturer	Model No.	Serial No.	Cal.Date	Next Cal. Date	Firmware Version	Software version
Wireless Connectivity Tester	R&S	CMW 270	102593	2023.05.20	2024.05.19	V 4.0.60	N/A
Coaxial Cable	N/A	N/A	2477	2023.06.08	2024.06.07	N/A	N/A
Coaxial Cable	N/A	N/A	2478	2023.06.08	2024.06.07	N/A	N/A
High and low temperature and fast temperature change test box	ASTUOD	ASTD-FBT-225K	N/A	2023.05.20	2024.05.19	N/A	N/A
Temperature/Humidity Meter	RTS	RTS-8S	RF08	2023.08.25	2024.08.24	N/A	N/A
Test system							
Instrument	Manufacturer	Model No.	Serial No.	Cal.Date	Next Cal. Date	Firmware Version	Software version
MAX Signal Analyzer	Keysight	N9010A	MY48030494	2022.12.08	2023.12.07	A.14.03	N/A
RF Control Unit	Tonscend	JS0806-2	22G8060594	2023.02.04	2024.02.03	N/A	N/A
MXG-B RF Vector Signal Generator	Keysight	N5182B	MY61252529	2023.05.20	2024.05.19	B.01.96	N/A
Frequency extender for EXG or MXG	Keysight	N5182BX07	MY59362500	2023.05.20	2024.05.19	N/A	N/A
EXG-B MW Analog Signal Generator	Keysight	N5173B	MY61252566	2023.08.26	2024.08.25	B.01.95	N/A
Test Software	Tonscend	TS1120	JS1120-3	N/A	N/A	N/A	V3.0.22

Radiated Emission(9kHz-1GHz) / AC3

Instrument	Manufacturer	Model No.	Serial No.	Cal. Date	Next Cal. Date	Firmware Version	Software version
EMI Test Receiver	R&S	ESCI	100573	2023.09.17	2024.09.16	4.42 SP3	N/A
Loop Antenna	R&S	HFH2-Z2E	101149	2023.04.25	2024.04.24	N/A	N/A
Bilog Antenna	Teseq GmbH	CBL6112D	27611	2023.02.20	2024.02.19	N/A	N/A
Temperature/Humidity Meter	RTS	RTS-8S	AC2-TH	2023.05.19	2024.05.18	N/A	N/A
Coaxial Cable	Huber+Suhner	SUCOFLEX 106	AC2-C	2023.05.21	2024.05.20	N/A	N/A
Dekra test software	Dekra	N/A	N/A	N/A	N/A	N/A	3

Radiated Emission (1GHz-40GHz) / AC5

Instrument	Manufacturer	Model No.	Serial No.	Cal. Date	Next Cal. Date	Firmware Version	Software version
EXA Spectrum Analyzer	Keysight	N9020B	MY60112218	2022.12.08	2023.12.07	A.31.05	N/A
Pre-Amplifier	SKET	LNPA_0118G-45	SK2021090101	2023.05.14	2024.05.13	N/A	N/A
Preamplifier	CHENGYI	EMC184045SE	980263	2023.07.09	2024.07.08	N/A	N/A
DRG Horn	ETS-Lindgren	3117	00123988	2022.11.01	2023.10.31	N/A	N/A
Broad-Band Horn Antenna	Schwarzbeck	BBHA9170	294	2023.05.31	2024.05.30	N/A	N/A
Filter Switch Box	MVE	MSW-F196	C070001S	2023.05.21	2024.05.20	N/A	N/A
Temperature/Humidity Meter	RTS	RTS-8S	AC5-TH	2023.05.19	2024.05.18	N/A	N/A
Coaxial Cable	TIMES	HF290A-NMNM-5.00M	651945-0001	2022.11.19	2023.11.18	N/A	N/A
Coaxial Cable	TIMES	HF290A-NMNM-6.00M	651946-0001	2022.11.19	2023.11.18	N/A	N/A
Coaxial Cable	TIMES	HF290A-NMNM-0.50M	651944-0001	2022.11.19	2023.11.18	N/A	N/A
Dekra test software	Dekra	N/A	N/A	N/A	N/A	N/A	3

UNCERTAINTY

Uncertainties have been calculated according to the DEKRA internal document. The reported expanded uncertainties are based on a standard uncertainty multiplied by a coverage factor of $k=2$, providing a level of confidence of approximately 95%. The Uncertainties is comply with standard required as below.

Test item	Uncertainty
AC Power Line Conducted Emission	9kHz~150kHz: 2.80dB 150kHz~30MHz: 2.40dB
Radiated Emission(30MHz~1GHz)	Horizontal: 30MHz~200MHz: 3.50 dB 300MHz~1GHz: 3.60 dB Vertical: 30MHz~200MHz: 3.60 dB 300MHz~1GHz: 3.50 dB
Radiated Emission(1GHz~26.5GHz)	Horizontal: 1GHz~18GHz: 5.00 dB Vertical: 1GHz~18GHz: 4.80 dB
20dB Bandwidth	± 1 kHz
Carrier Frequency Separation	± 1 kHz
Number of Hopping Frequencies	± 1 kHz
Time of Occupancy (Dwell Time)	± 0.1 us
Peak OutputPower	± 1.27 dB
Emissions in non-restricted frequency bands	± 1.0 dB
Radiated Emission Band Edge	± 3.9 dB

1 GENERAL INFORMATION

1.1 General Description of the Item(s)

Product Name.....:	IEEE 802.11a/b/g/n/ac 2T2R USB Wi-Fi Module Integrated Bluetooth 2.1+EDR/4.2/5.1
Model No.:	SKI.WB663U.2
FCC ID.....:	2AR82-SKIWB663U21
IC.....:	24728-SKIWB663U21
Manufacturer	Guangzhou Shikun Electronics Co., Ltd
Manufacturer Address	NO.6 Liankun Road, Huangpu District, Guangzhou 510530, China
Factory.....:	Guangzhou Shikun Electronics Co., Ltd
Factory address.....:	NO.6 Liankun Road, Huangpu District, Guangzhou 510530, China

Wireless specification.....:	Bluetooth V5.1					
Operating frequency range(s).....:	2402~2480 MHz					
Type of Modulation	GFSK					
PHYs	<input checked="" type="checkbox"/>	GFSK	<input checked="" type="checkbox"/>	Pi/4 DQPSK	<input checked="" type="checkbox"/>	8DPSK
Data Rate	<input checked="" type="checkbox"/>	1Mbit/s	<input checked="" type="checkbox"/>	2Mbit/s	<input checked="" type="checkbox"/>	3Mbit/s
Number of channel	79					

Rated power supply	Voltage and Frequency				
	<input type="checkbox"/>	AC: 220 - 240 Vac, 50/60 Hz			
	<input type="checkbox"/>	AC: 100 - 240 Vac, 50/60 Hz			
	<input checked="" type="checkbox"/>	DC: 3.3 Vdc			
	<input type="checkbox"/>	Battery:			
	<input type="checkbox"/>	Adapter:			
Brand of adapter	N/A				
Adapter model.....:	N/A				
Mounting position.....:	<input type="checkbox"/>	Table top equipment			
	<input type="checkbox"/>	Wall/Ceiling mounted equipment			
	<input type="checkbox"/>	Floor standing equipment			
	<input type="checkbox"/>	Hand-held/Portable equipment			
	<input checked="" type="checkbox"/>	Other: RF Module			

1.2 Antenna Information

Antenna model / type number	N/A	SLK-BOE-2915A-L-250I-G	N14-0899-R0A
Antenna serial number	61005-00712	61005-00718	61005-00713
Antenna Delivery	<input checked="" type="checkbox"/>	1TX + 1RX	
	<input type="checkbox"/>	2TX + 2RX	
	<input type="checkbox"/>	Others:.....	
Antenna technology.....	<input checked="" type="checkbox"/>	SISO	
	<input type="checkbox"/>	MIMO	<input type="checkbox"/> CDD
			<input type="checkbox"/> Beam-forming
Antenna Type	<input checked="" type="checkbox"/>	External	<input type="checkbox"/> Dipole
			<input type="checkbox"/> Sectorized
			<input checked="" type="checkbox"/> PIFA
	<input type="checkbox"/>	Internal	<input type="checkbox"/> PIFA
			<input type="checkbox"/> PCB
			<input type="checkbox"/> Dipole
			<input type="checkbox"/> Others.....
Antenna Gain.....	61005-00712: 2.60 dBi 61005-00713: 3.84 dBi 61005-00718: 3.86 dBi		
	Note: The antenna used in the test had the highest gain of material number 61005-00718.		

1.3 Channel List

Bluetooth Working Frequency of Each Channel: (For FHSS)							
Channel	Frequency	Channel	Frequency	Channel	Frequency	Channel	Frequency
00	2402 MHz	01	2403 MHz	02	2404 MHz	03	2405 MHz
04	2406 MHz	05	2407 MHz	06	2408 MHz	07	2409 MHz
08	2410 MHz	09	2411 MHz	10	2412 MHz	11	2413 MHz
12	2414 MHz	13	2415 MHz	14	2416 MHz	15	2417 MHz
16	2418 MHz	17	2419 MHz	18	2420 MHz	19	2421 MHz
20	2422 MHz	21	2423 MHz	22	2424 MHz	23	2425 MHz
24	2426 MHz	25	2427 MHz	26	2428 MHz	27	2429 MHz
28	2430 MHz	29	2431 MHz	30	2432 MHz	31	2433 MHz
32	2434 MHz	33	2435 MHz	34	2436 MHz	35	2437 MHz
36	2438 MHz	37	2439 MHz	38	2440 MHz	39	2441 MHz
40	2442 MHz	41	2443 MHz	42	2444 MHz	43	2445 MHz
44	2446 MHz	45	2447 MHz	46	2448 MHz	47	2449 MHz
48	2450 MHz	49	2451 MHz	50	2452 MHz	51	2453 MHz
52	2454 MHz	53	2455 MHz	54	2456 MHz	55	2457 MHz
56	2458 MHz	57	2459 MHz	58	2460 MHz	59	2461 MHz
60	2462 MHz	61	2463 MHz	62	2464 MHz	63	2465 MHz
64	2466 MHz	65	2467 MHz	66	2468 MHz	67	2469 MHz
68	2470 MHz	69	2471 MHz	70	2472 MHz	71	2473 MHz
72	2474 MHz	73	2475 MHz	74	2476 MHz	75	2477 MHz
76	2478 MHz	77	2479 MHz	78	2480 MHz	N/A	N/A

Note: The general description of the Item(s), antenna information and channel list in clause 1 are provided and confirmed by the client.

2 DESCRIPTION OF TEST SETUP

2.1 Operating mode(s) used for tests

During the tests the following operating mode(s) has(have) been used.

Test Mode For Bluetooth	Mode 1: Transmitter-1Mbps(GFSK_DH5)
	Mode 2: Transmitter-2Mbps(Pi/4 DQPSK_DH5)
	Mode 3: Transmitter-3Mbps(8DPSK_DH5)
	Mode 4: Transmitter-Hopping-1Mbps(GFSK_DH5)
	Mode 5: Transmitter-Hopping-2Mbps(Pi/4 DQPSK_DH5)
	Mode 6: Transmitter-Hopping-3Mbps(8DPSK_DH5)

2.2 Auxiliary equipment /Accessories/Test software for the EUT

Auxiliary equipment	Type / Version	Manufacturer	Supplied by
(1) Notebook	Think pad x220	Lenovo	Adapter
(2) USB Control Cable	N/A	N/A	N/A
(3) USB Control Cable	N/A	N/A	N/A
software	Type / Version	Manufacturer	Supplied by
MT7663_Win10_Driver_QA_Combo_Tool	N/A	N/A	N/A

Accessories Information	Cable		
	Length used during test [m]	Attached during test	Shielded
(2)USB Control Cable	1	<input checked="" type="checkbox"/>	<input checked="" type="checkbox"/>
(3)USB Control Cable	8	<input checked="" type="checkbox"/>	<input checked="" type="checkbox"/>

2.3 Test Configuration / Block diagram used for tests

Test setup Diagram- Conducted test

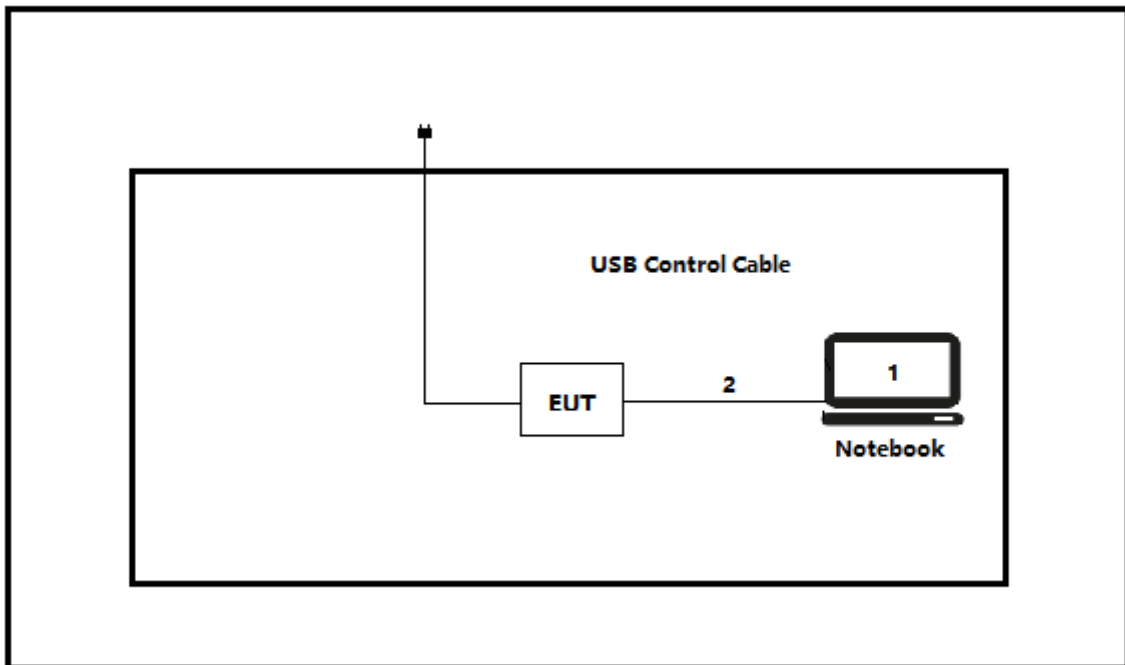

Test setup Diagram- Radiated test

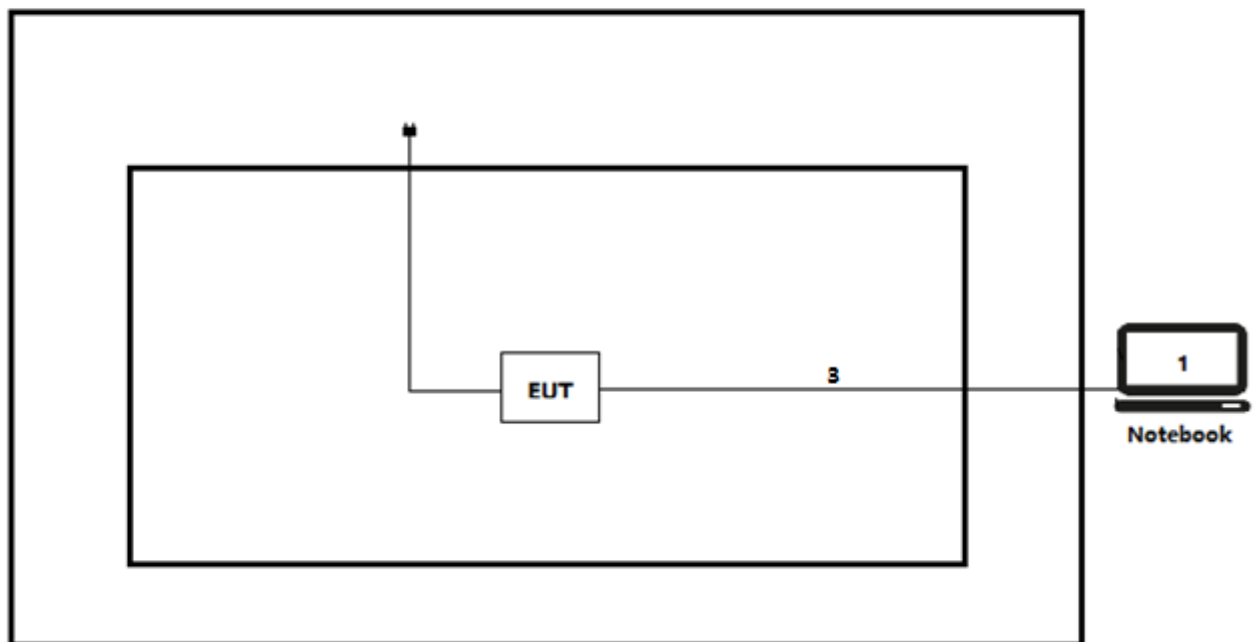

2.4 Testing process

1	Setup the EUT shown in Section 2.3.
2	Execute the [MT7663_Win10_Driver_QA_Combo_Tool] on the notebook.
3	Configure the test mode, the test channel, and the data rate.
4	Verify that the EUT works properly.

3 VERDICT SUMMARY SECTION

This chapter presents an overview of standards and results. Refer to the next chapters for details of measured test results and applied test levels.

3.1 Standards

Standard	Year	Description
FCC CFR Title 47 Part 15 Subpart E Section 15.247	2023	Operation within the bands 902–928 MHz, 2400–2483.5 MHz, and 5725–5850 MHz.
ANSI C63.10	2013	American National Standard of Procedures for Compliance Testing of Unlicensed Wireless Devices
KDB558074 D01 v05r02	2019	Guidance for performing compliance measurements on Digital Transmission System (DTS) operating under section 15.247
RSS-Gen	2019	General Requirements for Compliance of Radio Apparatus
RSS-247	2017	Digital Transmission Systems (DTSs), Frequency Hopping Systems (FHSs) and Licence-Exempt Local Area Network (LE-LAN) Devices

3.2 Deviation(s) from the Standard(s) / Test Specification(s)

The following deviation(s) was / were made from the published requirements of the listed standards: N/A.

(Please define the deviations from the standard(s) if applicable)

3.3 Overview of results

Requirement – Test Item of FCC	Standard(s)	Verdict	Remark
Maximum conducted output power	FCC 15.247(b)3 RSS-247 Issue 2 Paragraph 5.4(b)	PASS	Test data please refer to Appendix A
Band edge measurements	FCC 15.247(d) FCC 15.205 FCC 15.209 RSS-Gen Issue 5 Paragraph 8.10	PASS	Test data please refer to Appendix B
Emissions in Restricted Bands	FCC 15.205 FCC 15.209 RSS-Gen Issue 5 Paragraph 8.9	PASS	Test data please refer to Appendix C
Antenna Requirement	FCC 15.203 RSS-Gen Issue 5 Paragraph 6.8	PASS	---

3.4 Power setting in test

Mode	Channel	Frequency (MHz)	Power setting
1Mbps(GFSK_DH5)	00~78	2402~2480	5
2Mbps(Pi/4 DQPSK_DH5)	00~78	2402~2480	6
3Mbps(8DPSK_DH5)	00~78	2402~2480	6

3.5 Test Matrix

Test item	Model: SKI.WB663U.2		
	1(#1)	2()	3()
20dB Emission Bandwidth	<input type="checkbox"/>	<input type="checkbox"/>	<input type="checkbox"/>
Maximum conducted output power	<input type="checkbox"/>	<input type="checkbox"/>	<input type="checkbox"/>
Carrier frequency separation	<input type="checkbox"/>	<input type="checkbox"/>	<input type="checkbox"/>
Time of occupancy	<input type="checkbox"/>	<input type="checkbox"/>	<input type="checkbox"/>
Number of Hopping Frequencies	<input type="checkbox"/>	<input type="checkbox"/>	<input type="checkbox"/>
Band edge measurements	<input checked="" type="checkbox"/>	<input type="checkbox"/>	<input type="checkbox"/>
Conducted Spurious Emission	<input type="checkbox"/>	<input type="checkbox"/>	<input type="checkbox"/>
Duty cycle	<input type="checkbox"/>	<input type="checkbox"/>	<input type="checkbox"/>
Emissions in Restricted Bands	<input checked="" type="checkbox"/>	<input type="checkbox"/>	<input type="checkbox"/>
AC Power Line Conducted Emission	<input type="checkbox"/>	<input type="checkbox"/>	<input type="checkbox"/>

3.6 Test Facility

USA : FCC Designation Number: CN1199

CA : ISED CAB identifier: CN0040

4 TEST ITEMS OF LIMIT/SETUP/PROCEDURE

4.1 Maximum conducted output power

VERDICT: PASS

4.1.1 Limit

Standard

FCC Part 15 Subpart C Paragraph 15.247 (a)(1)

<input checked="" type="checkbox"/>	Frequency hopping systems operating in the 2400-2483.5 MHz band employing at least 75 non-overlapping hopping channels, and all frequency hopping systems in the 5725-5850 MHz band: 1 watt. For all other frequency hopping systems in the 2400-2483.5 MHz band: 0.125 watts.
<input checked="" type="checkbox"/>	Frequency hopping systems operating in the 2400-2483.5 MHz band may have hopping channel carrier frequencies that are separated by 25 kHz or two-thirds of the 20 dB bandwidth of the hopping channel, whichever is greater, provided the systems operate with an output power no greater than 125 mW.
<input type="checkbox"/>	For frequency hopping systems operating in the 902-928 MHz band: 1 watt for systems employing at least 50 hopping channels; and, 0.25 watts for systems employing less than 50 hopping channels, but at least 25 hopping channels

4.1.2 Test Setup

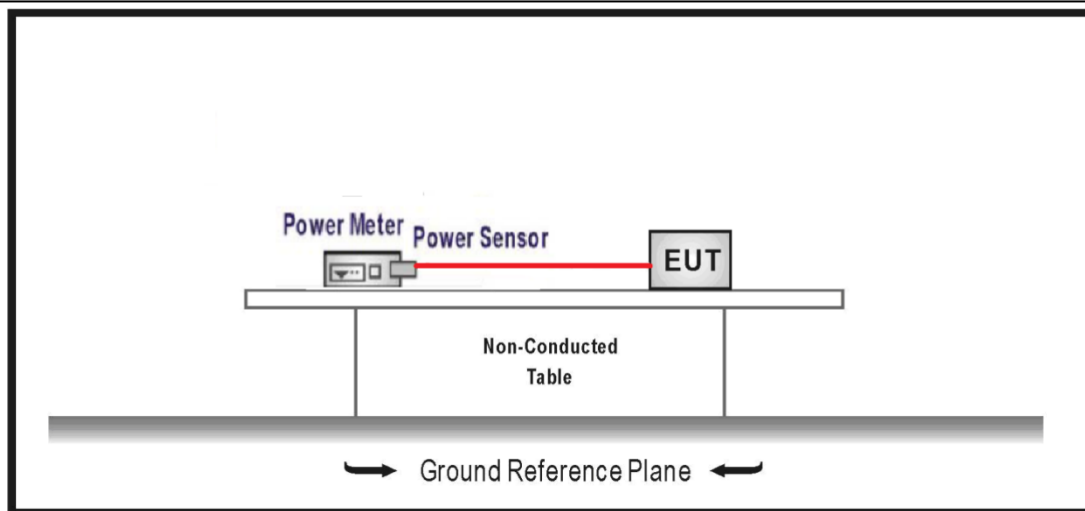

4.1.3 Test Procedure				
	References Rule		Chapter	Description
<input checked="" type="checkbox"/>	ANSI C63.10		7.8	Evaluation of frequency-hopping device parameters
	<input checked="" type="checkbox"/>	ANSI C63.10	7.8.5	Output power test procedure for frequency-hopping spread-spectrum (FHSS) devices

4.2 Band edge measurements	VERDICT: PASS
-----------------------------------	----------------------

4.2.1 Limit

Standard		FCC Part 15 Subpart C Paragraph 15.247(d) , 15.209;		
Frequency bands (MHz)	Detector	Limit (dBμV/m)	RBW (MHz)	Distance (m)
2310-2390	PK	74	1	3
2483.5-2500	AV	54	1	3

Note: The field strength of emissions appearing within these frequency bands shall not exceed the limits.

4.2.2 Test Setup

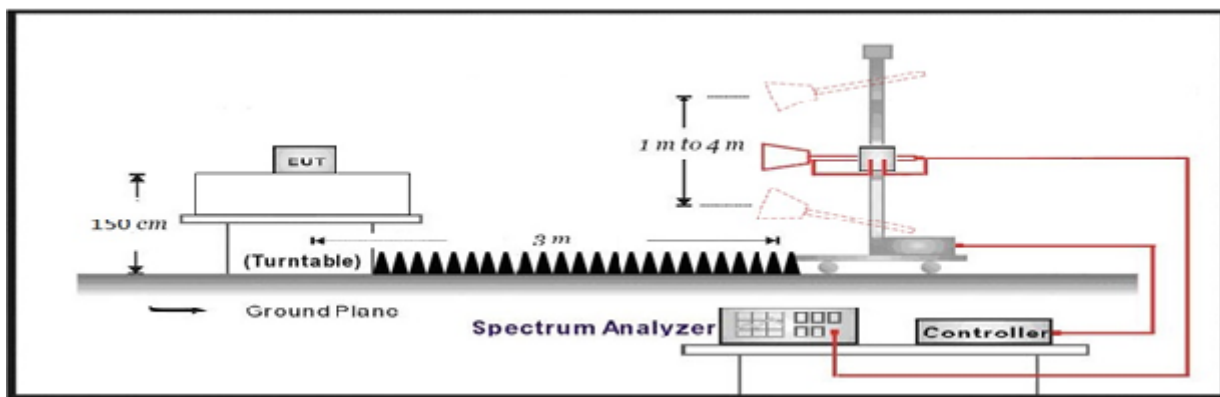

4.2.3 Test Procedure

Test Method			
	References Rule	Chapter	Description
<input type="checkbox"/>	DA 00-705	N/A	duty cycle correction factor
<input checked="" type="checkbox"/>	ANSI C63.10	6.10	Band-edge testing
	<input checked="" type="checkbox"/> ANSI C63.10	6.10.5	Restricted-band band-edge measurements
	<input type="checkbox"/> ANSI C63.10	6.10.6	Marker-delta method
<input type="checkbox"/>	ANSI C63.10	6.4	Radiated emissions from unlicensed wireless devices below 30 MHz
<input type="checkbox"/>	ANSI C63.10	6.5	Radiated emissions from unlicensed wireless devices in the frequency range of 30 MHz to 1000 MHz
<input type="checkbox"/>	ANSI C63.10	6.6	Radiated emissions from unlicensed wireless devices above 1 GHz

4.3 Emissions in Restricted Bands**VERDICT: PASS****4.3.1 Limit****Standard**

FCC Part 15 Subpart C Paragraph 15.205

Restricted Bands of operation

Frequency (MHz)	Frequency (MHz)	Frequency (MHz)	Frequency (GHz)
0.090 – 0.110	16.42 – 16.423	399.9 – 410	4.5 – 5.15
0.495 – 0.505	16.69475 – 16.69525	608 – 614	5.35 – 5.46
2.1735 – 2.1905	16.80425 – 16.80475	960 – 1240	7.25 – 7.75
4.125 – 4.128	25.5 – 25.67	1300 – 1427	8.025 – 8.5
4.17725 – 4.17775	37.5 – 38.25	1435 – 1626.5	9.0 – 9.2
4.20725 – 4.20775	73 – 74.6	1645.5 – 1646.5	9.3 – 9.5
6.215 – 6.218	74.8 – 75.2	1660 – 1710	10.6 – 12.7
6.26775 – 6.26825	108 – 121.94	1718.8 – 1722.2	13.25 – 13.4
6.31175 – 6.31225	123 – 138	2200 – 2300	14.47 – 14.5
8.291 – 8.294	149.9 – 150.05	2310 – 2390	15.35 – 16.2
8.362 – 8.366	156.52475 – 156.52525	2483.5 – 2500	17.7 – 21.4
8.37625 – 8.38675	156.7 – 156.9	2690 – 2900	22.01 – 23.12
8.81425 – 8.81475	162.0125 – 167.17	3260 – 3267	23.6 – 24.0
12.29 – 12.293	167.72 – 173.2	3332 – 3339	31.2 – 31.8
12.51975 – 12.52025	240 – 285	3345.8 – 3358	36.43 – 36.5
12.57675 – 12.57725	322 – 335.4	3600 – 4400	
13.36 – 13.41			

Restricted Band Emissions Limit

FCC Part 15 Subpart C Paragraph 15.209

Frequency (MHz)	Field strength (μV/m)	Field strength (dBμV/m)	Measurement distance (m)
0.009 - 0.49	2400/F(kHz)	48.5 – 13.8	300 _(Note 1)
0.49 - 1.705	24000/F(kHz)	33.8 - 23	30 _(Note 1)
1.705 - 30	30	29.5	30 _(Note 1)
30 - 88	100	40	3 _(Note 2)
88 - 216	150	43.5	3 _(Note 2)
216 - 960	200	46	3 _(Note 2)
Above 960	500	54	3 _(Note 2)

Note 1: At frequencies below 30 MHz, measurements may be performed at a distance closer than that specified in the regulations; however, an attempt should be made to avoid making measurements in the near field. Pending the development of an appropriate measurement procedure for measurements performed below 30 MHz, when performing measurements at a closer distance than specified, the results shall be extrapolated to the specified distance by either making measurements at a minimum of two distances on at least one radial to determine the proper extrapolation factor or by using the square of an inverse linear distance extrapolation factor (40 dB/decade).

Note 2: At frequencies at or above 30 MHz, measurements may be performed at a distance other than what is specified provided: measurements are not made in the near field except where it can be shown that near field measurements are appropriate due to the characteristics of the device; and it can be demonstrated that the signal levels needed to be measured at the distance employed can be detected by the measurement equipment. Measurements shall not be performed at a distance greater than 30 meters unless it can be further demonstrated that measurements at a distance of 30 meters or less are impractical. When performing measurements at a distance other than that specified, the results shall be extrapolated to the specified distance using an extrapolation factor of 20 dB/decade (inverse linear-distance for field strength measurements; inverse-linear-distance-squared for power density measurements).

4.3.2 Test Setup

Below 30MHz Test Setup:

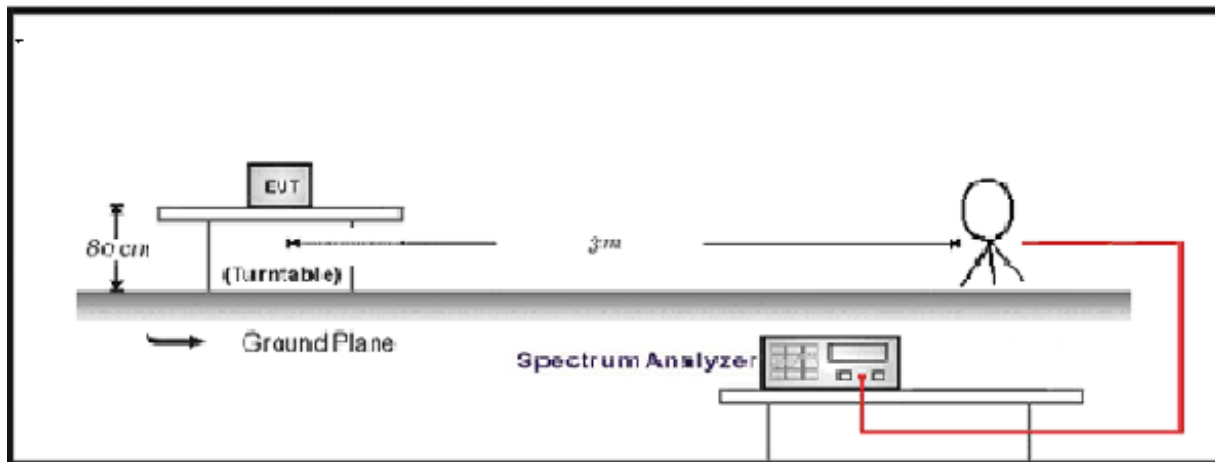

30MHz-1GHz Test Setup:

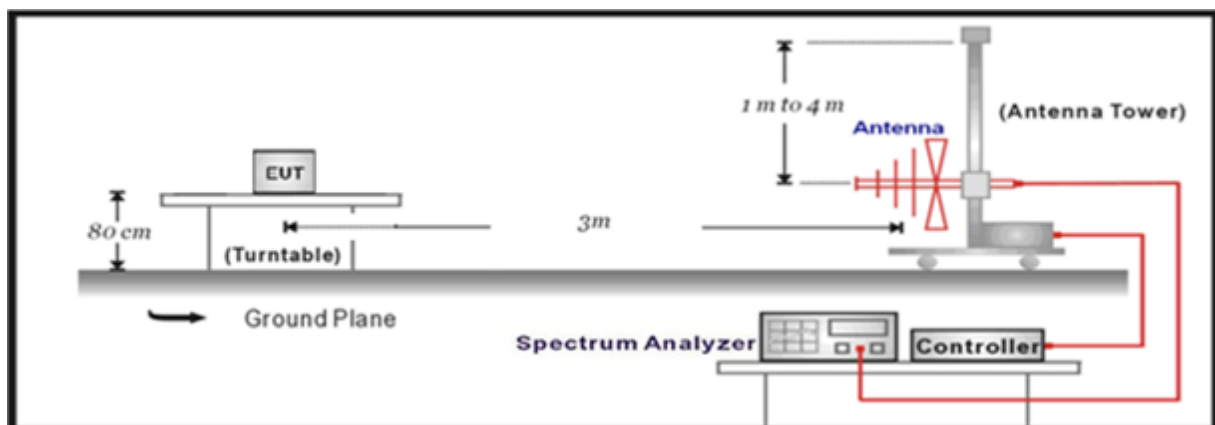

Above 1GHz Test Setup:

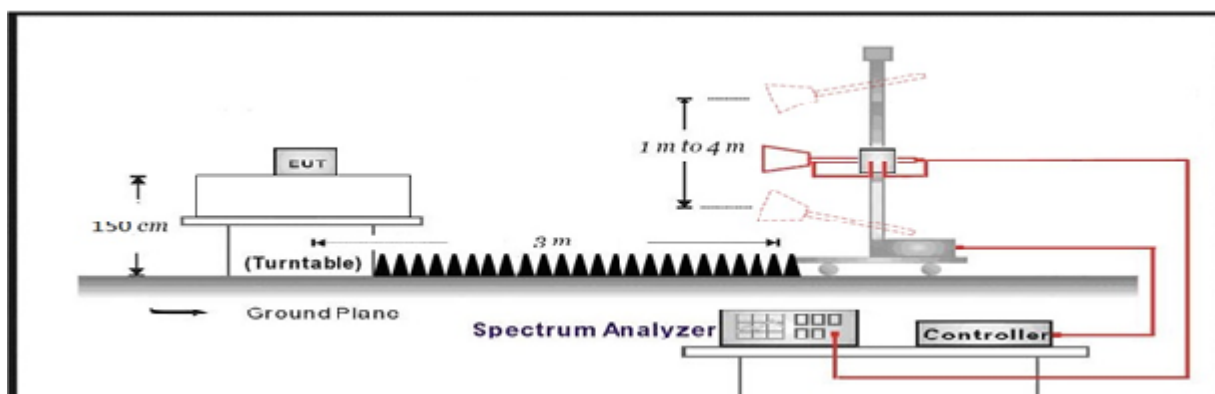

4.3.3 Test Procedure

	References Rule	Chapter	Description
<input checked="" type="checkbox"/>	ANSI C63.10	11.12	Emissions in restricted frequency bands
<input checked="" type="checkbox"/>	<input checked="" type="checkbox"/> ANSI C63.10	11.12.1	Radiated emission measurements
<input checked="" type="checkbox"/>	<input checked="" type="checkbox"/> ANSI C63.10	11.12.2.7	Radiated spurious emission test
<input checked="" type="checkbox"/>	<input checked="" type="checkbox"/> ANSI C63.10	6.4	Radiated emissions from unlicensed wireless devices below 30 MHz
<input checked="" type="checkbox"/>	<input checked="" type="checkbox"/> ANSI C63.10	6.5	Radiated emissions from unlicensed wireless devices in the frequency range of 30 MHz to 1000 MHz
<input checked="" type="checkbox"/>	<input checked="" type="checkbox"/> ANSI C63.10	6.6	Radiated emissions from unlicensed wireless devices above 1 GHz

4.4 Antenna Requirement

VERDICT: PASS

4.4.1 Limit

Standard

FCC Part 15 Subpart C Paragraph 15.247(d) , 15.209

An intentional radiator shall be designed to ensure that no antenna other than that furnished by the responsible party shall be used with the device. The use of a permanently attached antenna or of an antenna that uses a unique coupling to the intentional radiator shall be considered sufficient to comply with the provisions of this section. The manufacturer may design the unit so that a broken antenna can be replaced by the user, but the use of a standard antenna jack or electrical connector is prohibited. This requirement does not apply to carrier current devices or to devices operated under the provisions of §15.211, §15.213, §15.217, §15.219, or §15.221. Further, this requirement does not apply to intentional radiators that must be professionally installed, such as perimeter protection systems and some field disturbance sensors, or to other intentional radiators which, in accordance with §15.31(d), must be measured at the installation site. However, the installer shall be responsible for ensuring that the proper antenna is employed so that the limits in this part are not exceeded.

4.4.2 Antenna Connector Construction:

<input checked="" type="checkbox"/>	The use of a permanently attached antenna
<input type="checkbox"/>	The antenna use of a unique coupling to the intentional radiator
<input type="checkbox"/>	The use of a nonstandard antenna jack or electrical connector
Please refer to the attached document "Internal Photograph" to show the antenna connector.	

5 TEST SETUP PHOTO AND EUT PHOTO

Remark: The test setup photo and EUT Photo please see appendix.

6 TEST RESULT

Appendix A: RF Output Power

Mode	Channel	Test Frequency (MHz)	Conducted Power (dBm)	Conducted Power Limit (dBm)	EIRP (dBm)	EIRP Limit (dBm)	Result
Mode 1	00	2402	2.91	≤21	6.75	≤36	Pass
	39	2441	2.75	≤21	6.59	≤36	Pass
	78	2480	2.84	≤21	6.68	≤36	Pass
Mode 2	00	2402	4.95	≤21	8.79	≤36	Pass
	39	2441	4.83	≤21	8.67	≤36	Pass
	78	2480	4.97	≤21	8.81	≤36	Pass
Mode 3	00	2402	5.20	≤21	9.04	≤36	Pass
	39	2441	5.11	≤21	8.95	≤36	Pass
	78	2480	5.41	≤21	9.25	≤36	Pass

Note 1: EIRP = Conducted power + Antenna gain

Note 2: Please refer to callus 1.2 for antenna gain.

Appendix B: Band edge measurements

Profile: 2380793R	Page No.: 1
Engineer: Pengchengyang	
Site: AC5	Time: 2023/09/20 - 21:06
Limit: FCC_Part15.209_RE(3m)	Margin: 0
Probe: Horn_3117_00123988(1-18GHz)	Polarity: Horizontal
EUT: SKI.WB663U.2	Power: 3.3Vdc
Note: Mode 1: Transmit at 2402MHz by DH5	

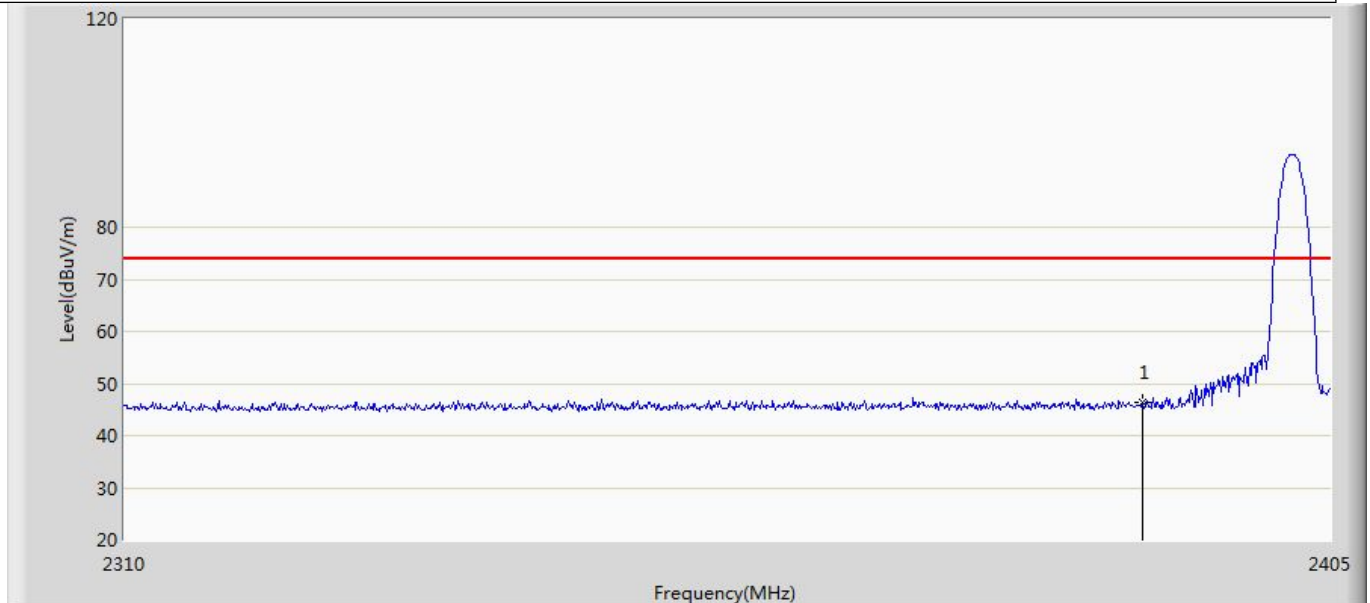

No	Mark	Frequency (MHz)	Measure Level (dBuV/m)	Reading Level (dBuV)	Over Limit (dB)	Limit (dBuV/m)	Factor (dB)	Type
1	*	2390.000	46.257	12.114	-27.743	74.000	34.143	PK

Profile: 2380793R	Page No.: 2
Engineer: Pengchengyang	
Site: AC5	Time: 2023/09/20 - 21:13
Limit: FCC_Part15.209_RE(3m)	Margin: 0
Probe: Horn_3117_00123988(1-18GHz)	Polarity: Horizontal
EUT: SKI.WB663U.2	Power: 3.3Vdc
Note: Mode 1: Transmit at 2402MHz by DH5	

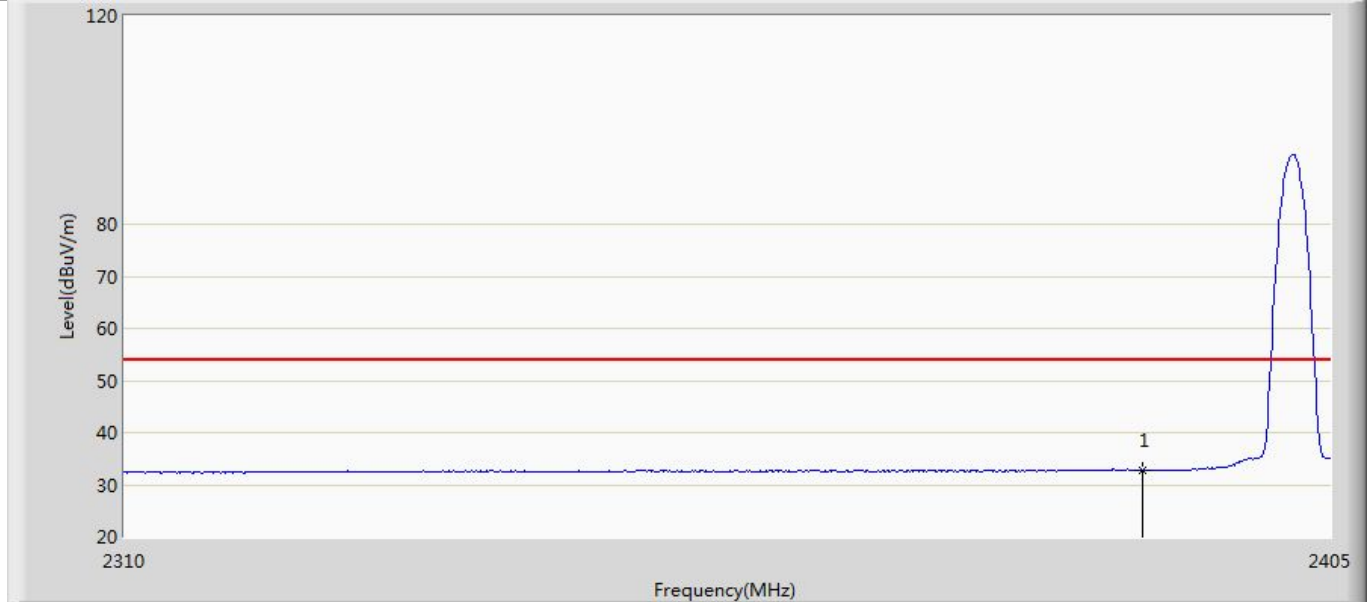

No	Mark	Frequency (MHz)	Measure Level (dBuV/m)	Reading Level (dBuV)	Over Limit (dB)	Limit (dBuV/m)	Factor (dB)	Type
1	*	2390.000	32.746	-1.397	-21.254	54.000	34.143	AV

Profile: 2380793R	Page No.: 3
Engineer: Pengchengyang	
Site: AC5	Time: 2023/09/20 - 21:15
Limit: FCC_Part15.209_RE(3m)	Margin: 0
Probe: Horn_3117_00123988(1-18GHz)	Polarity: Vertical
EUT: SKI.WB663U.2	Power: 3.3Vdc
Note: Mode 1: Transmit at 2402MHz by DH5	

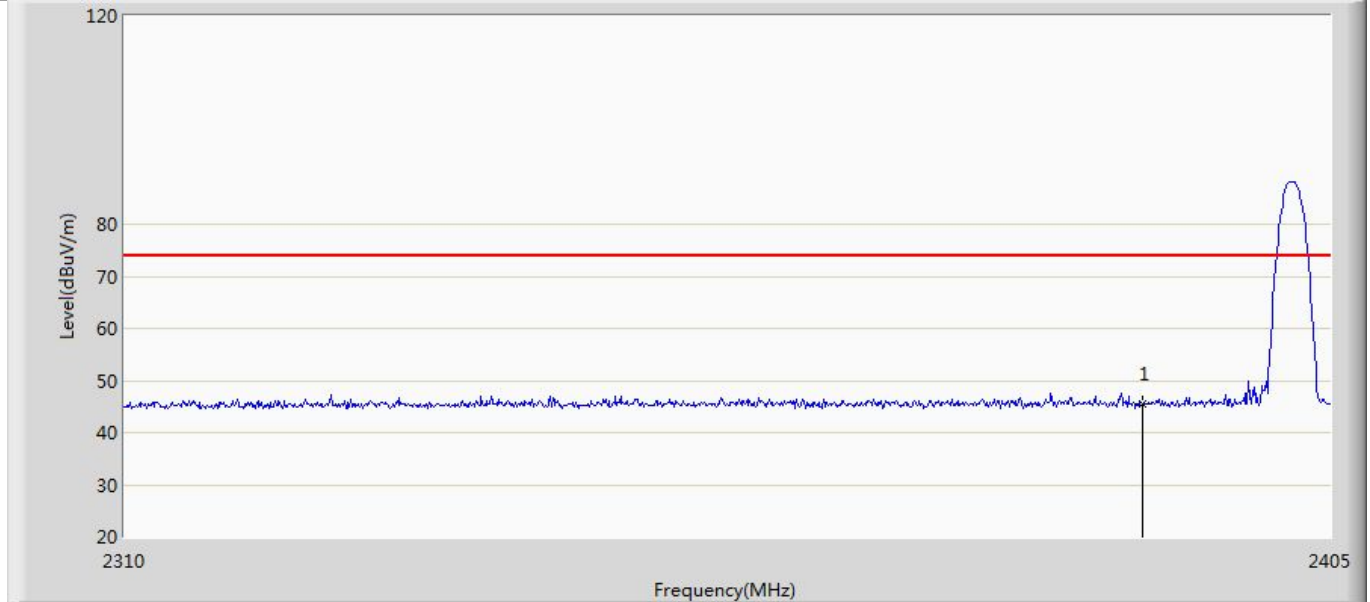

No	Mark	Frequency (MHz)	Measure Level (dBuV/m)	Reading Level (dBuV)	Over Limit (dB)	Limit (dBuV/m)	Factor (dB)	Type
1	*	2390.000	45.570	11.427	-28.430	74.000	34.143	PK

Profile: 2380793R	Page No.: 4
Engineer: Pengchengyang	
Site: AC5	Time: 2023/09/20 - 21:18
Limit: FCC_Part15.209_RE(3m)	Margin: 0
Probe: Horn_3117_00123988(1-18GHz)	Polarity: Vertical
EUT: SKI.WB663U.2	Power: 3.3Vdc
Note: Mode 1: Transmit at 2402MHz by DH5	

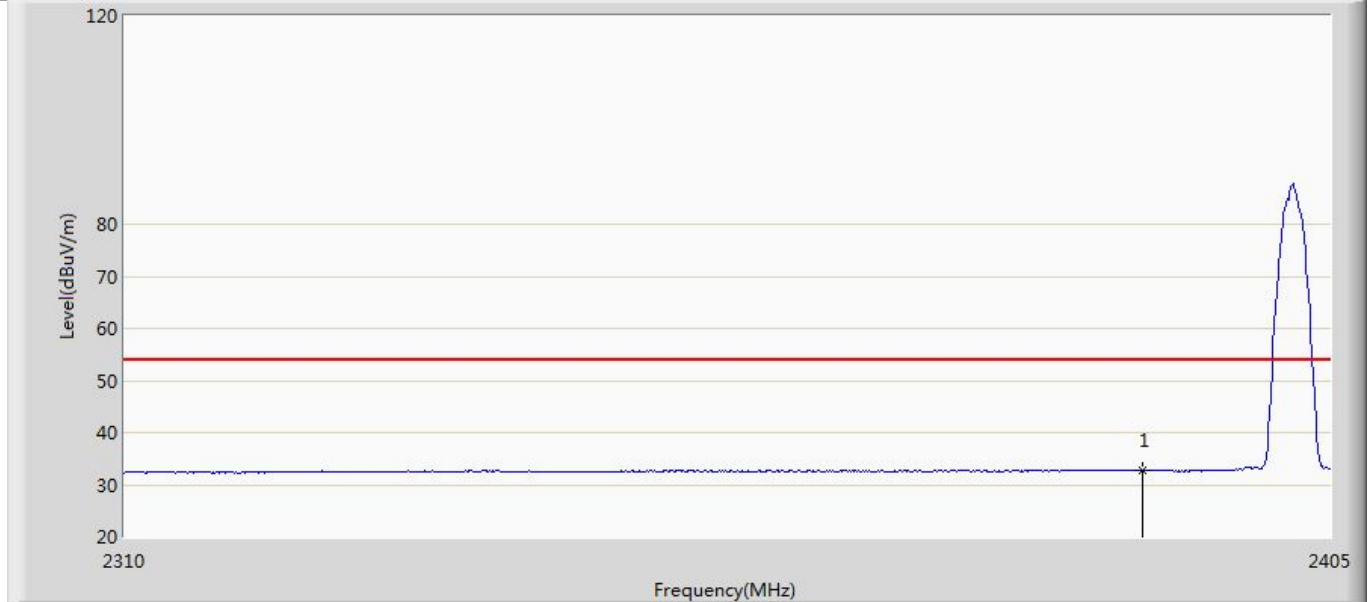

No	Mark	Frequency (MHz)	Measure Level (dBuV/m)	Reading Level (dBuV)	Over Limit (dB)	Limit (dBuV/m)	Factor (dB)	Type
1	*	2390.000	32.692	-1.451	-21.308	54.000	34.143	AV

Profile: 2380793R	Page No.: 5
Engineer: Pengchengyang	
Site: AC5	Time: 2023/09/20 - 21:20
Limit: FCC_Part15.209_RE(3m)	Margin: 0
Probe: Horn_3117_00123988(1-18GHz)	Polarity: Horizontal
EUT: SKI.WB663U.2	Power: 3.3Vdc
Note: Mode 1: Transmit at 2480MHz by DH5	

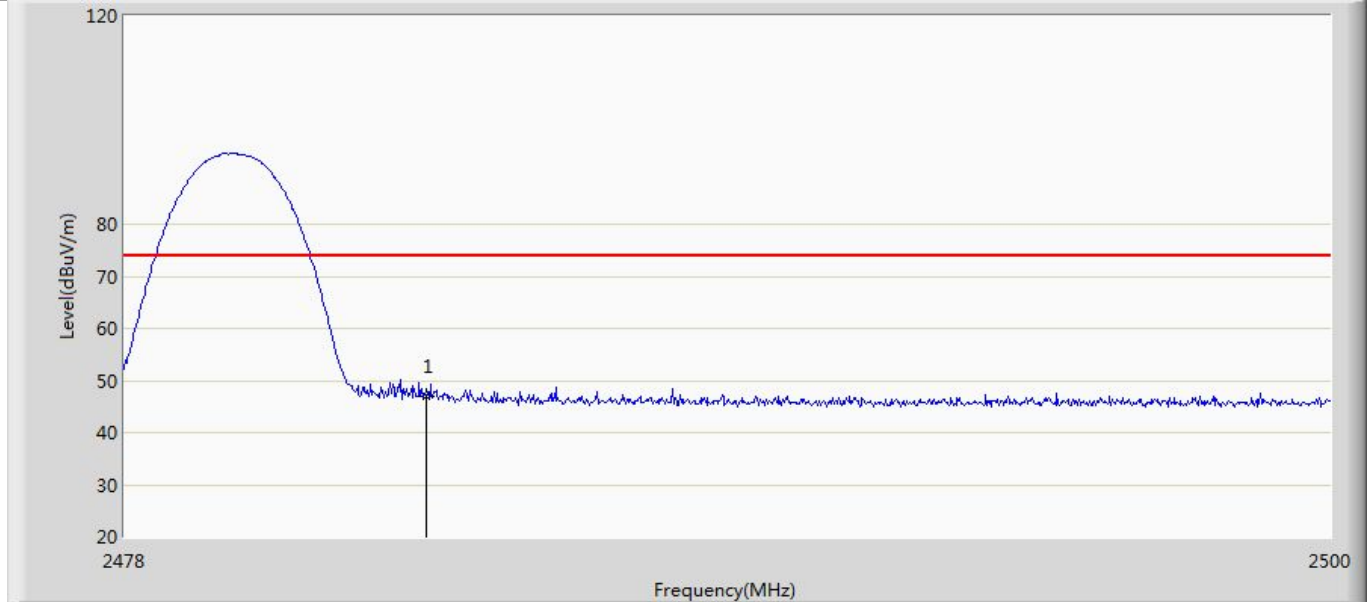

No	Mark	Frequency (MHz)	Measure Level (dBuV/m)	Reading Level (dBuV)	Over Limit (dB)	Limit (dBuV/m)	Factor (dB)	Type
1	*	2483.500	46.951	12.669	-27.049	74.000	34.282	PK

Profile: 2380793R	Page No.: 6
Engineer: Pengchengyang	
Site: AC5	Time: 2023/09/20 - 21:21
Limit: FCC_Part15.209_RE(3m)	Margin: 0
Probe: Horn_3117_00123988(1-18GHz)	Polarity: Horizontal
EUT: SKI.WB663U.2	Power: 3.3Vdc
Note: Mode 1: Transmit at 2480MHz by DH5	

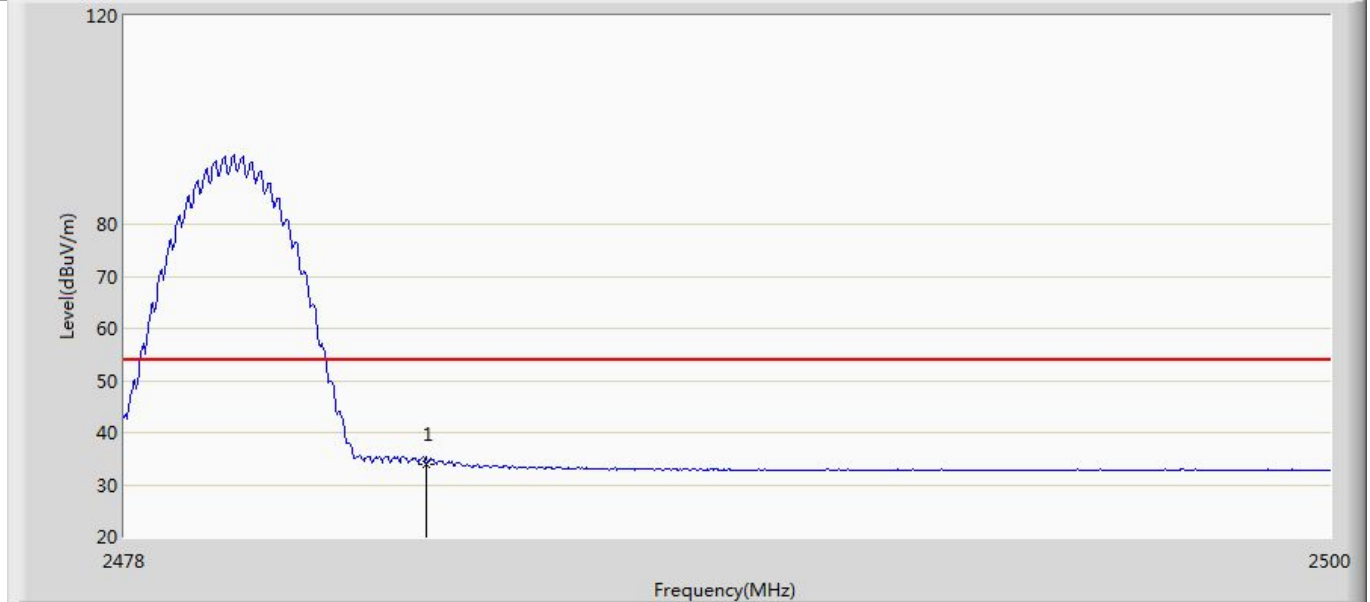

No	Mark	Frequency (MHz)	Measure Level (dBuV/m)	Reading Level (dBuV)	Over Limit (dB)	Limit (dBuV/m)	Factor (dB)	Type
1	*	2483.500	33.994	-0.288	-20.006	54.000	34.282	AV

Profile: 2380793R	Page No.: 7
Engineer: Pengchengyang	
Site: AC5	Time: 2023/09/20 - 21:22
Limit: FCC_Part15.209_RE(3m)	Margin: 0
Probe: Horn_3117_00123988(1-18GHz)	Polarity: Vertical
EUT: SKI.WB663U.2	Power: 3.3Vdc
Note: Mode 1: Transmit at 2480MHz by DH5	

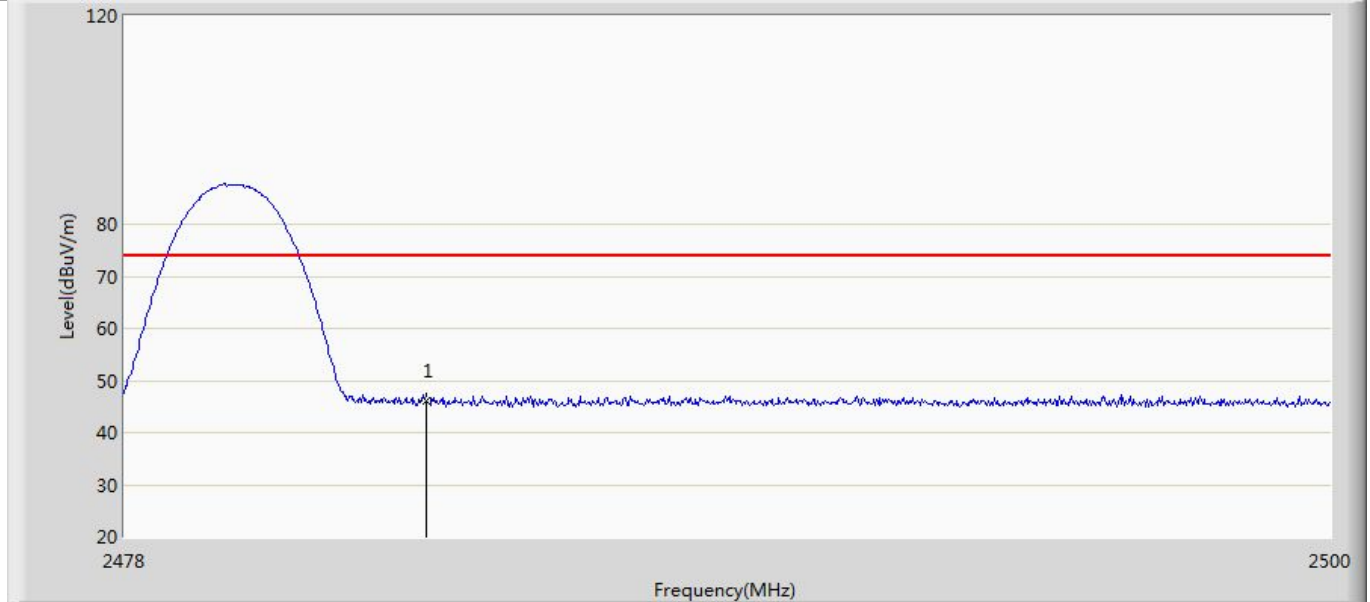

No	Mark	Frequency (MHz)	Measure Level (dBuV/m)	Reading Level (dBuV)	Over Limit (dB)	Limit (dBuV/m)	Factor (dB)	Type
1	*	2483.500	46.021	11.739	-27.979	74.000	34.282	PK

Profile: 2380793R	Page No.: 8
Engineer: Pengchengyang	
Site: AC5	Time: 2023/09/20 - 21:23
Limit: FCC_Part15.209_RE(3m)	Margin: 0
Probe: Horn_3117_00123988(1-18GHz)	Polarity: Vertical
EUT: SKI.WB663U.2	Power: 3.3Vdc
Note: Mode 1: Transmit at 2480MHz by DH5	

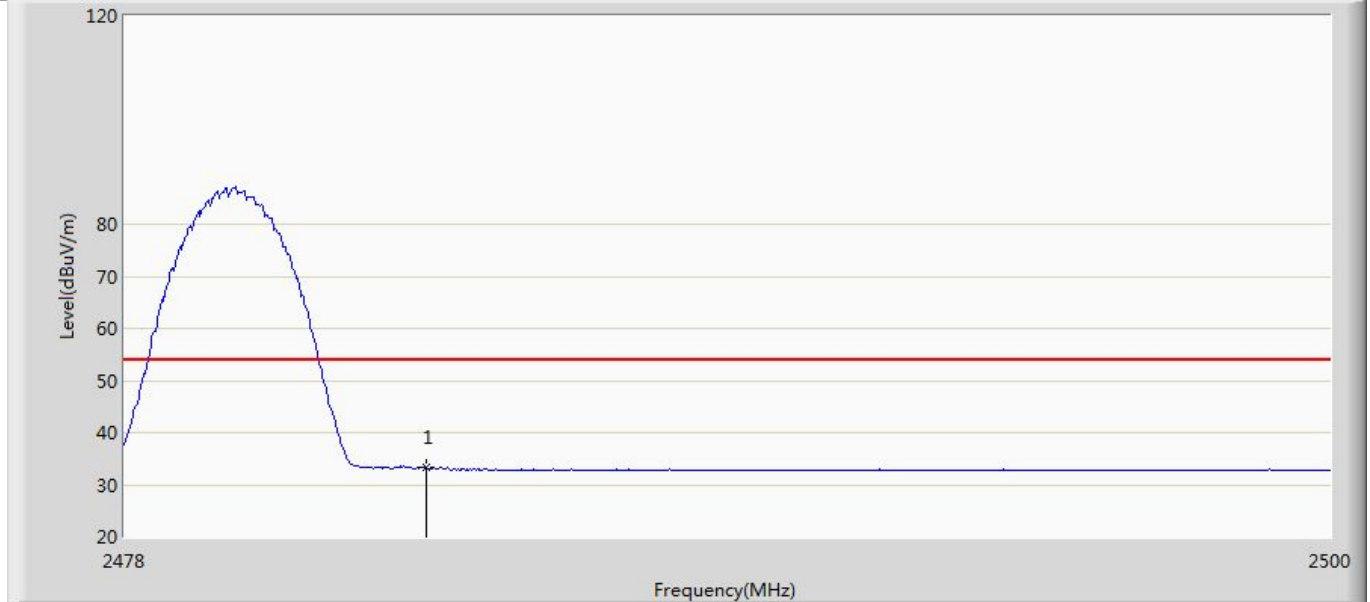

No	Mark	Frequency (MHz)	Measure Level (dBuV/m)	Reading Level (dBuV)	Over Limit (dB)	Limit (dBuV/m)	Factor (dB)	Type
1	*	2483.500	33.293	-0.989	-20.707	54.000	34.282	AV

Profile: 2380793R	Page No.: 9
Engineer: Pengchengyang	
Site: AC5	Time: 2023/09/20 - 21:24
Limit: FCC_Part15.209_RE(3m)	Margin: 0
Probe: Horn_3117_00123988(1-18GHz)	Polarity: Horizontal
EUT: SKI.WB663U.2	Power: 3.3Vdc
Note: Mode 2: Transmit at 2402MHz by 2DH5	

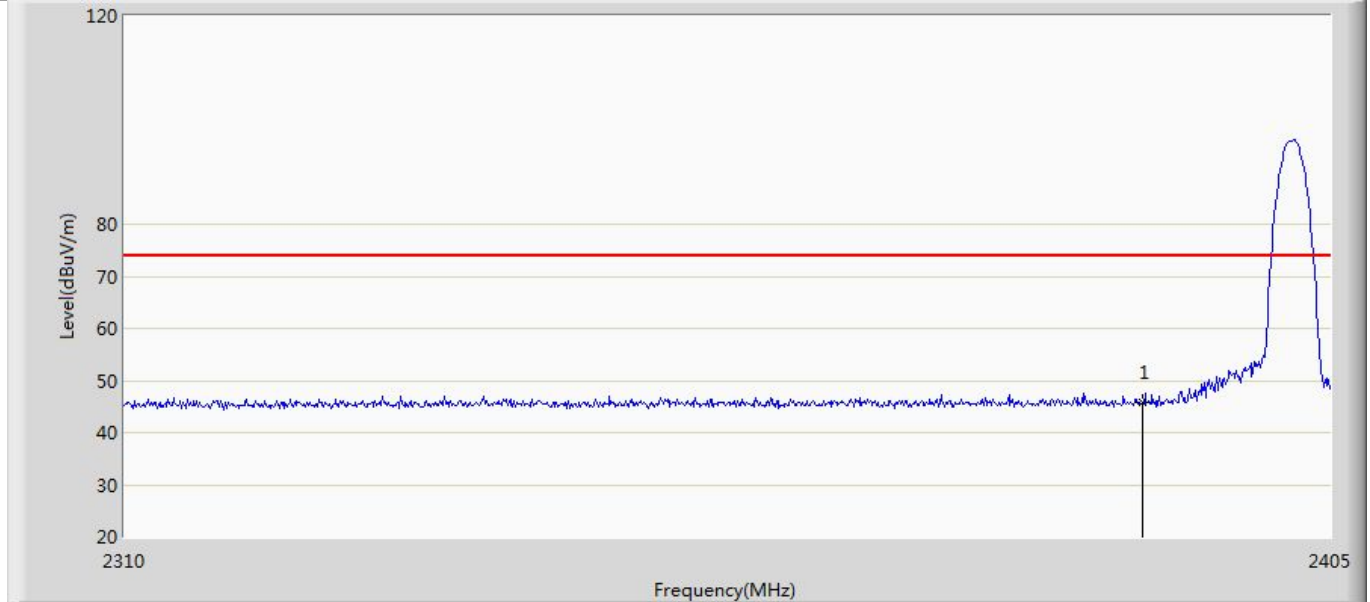

No	Mark	Frequency (MHz)	Measure Level (dBuV/m)	Reading Level (dBuV)	Over Limit (dB)	Limit (dBuV/m)	Factor (dB)	Type
1	*	2390.000	45.891	11.748	-28.109	74.000	34.143	PK

Profile: 2380793R	Page No.: 10
Engineer: Pengchengyang	
Site: AC5	Time: 2023/09/20 - 21:26
Limit: FCC_Part15.209_RE(3m)	Margin: 0
Probe: Horn_3117_00123988(1-18GHz)	Polarity: Horizontal
EUT: SKI.WB663U.2	Power: 3.3Vdc
Note: Mode 2: Transmit at 2402MHz by 2DH5	

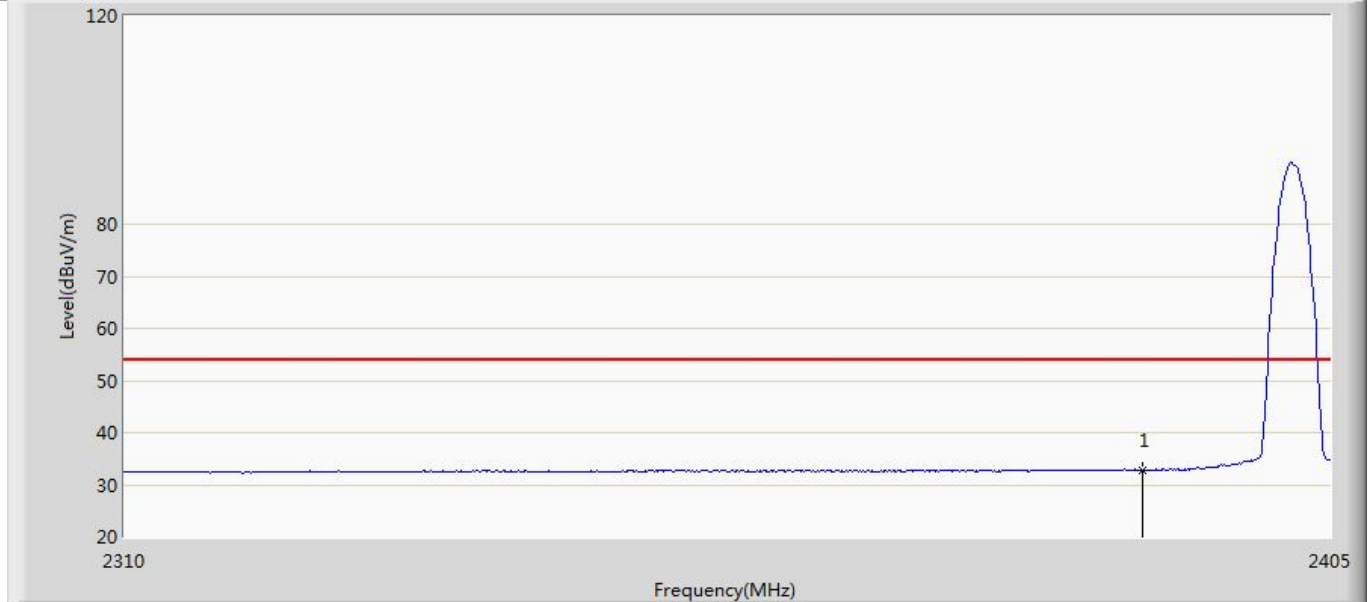

No	Mark	Frequency (MHz)	Measure Level (dBuV/m)	Reading Level (dBuV)	Over Limit (dB)	Limit (dBuV/m)	Factor (dB)	Type
1	*	2390.000	32.717	-1.426	-21.283	54.000	34.143	AV

Profile: 2380793R	Page No.: 11
Engineer: Pengchengyang	
Site: AC5	Time: 2023/09/20 - 21:27
Limit: FCC_Part15.209_RE(3m)	Margin: 0
Probe: Horn_3117_00123988(1-18GHz)	Polarity: Vertical
EUT: SKI.WB663U.2	Power: 3.3Vdc
Note: Mode 2: Transmit at 2402MHz by 2DH5	

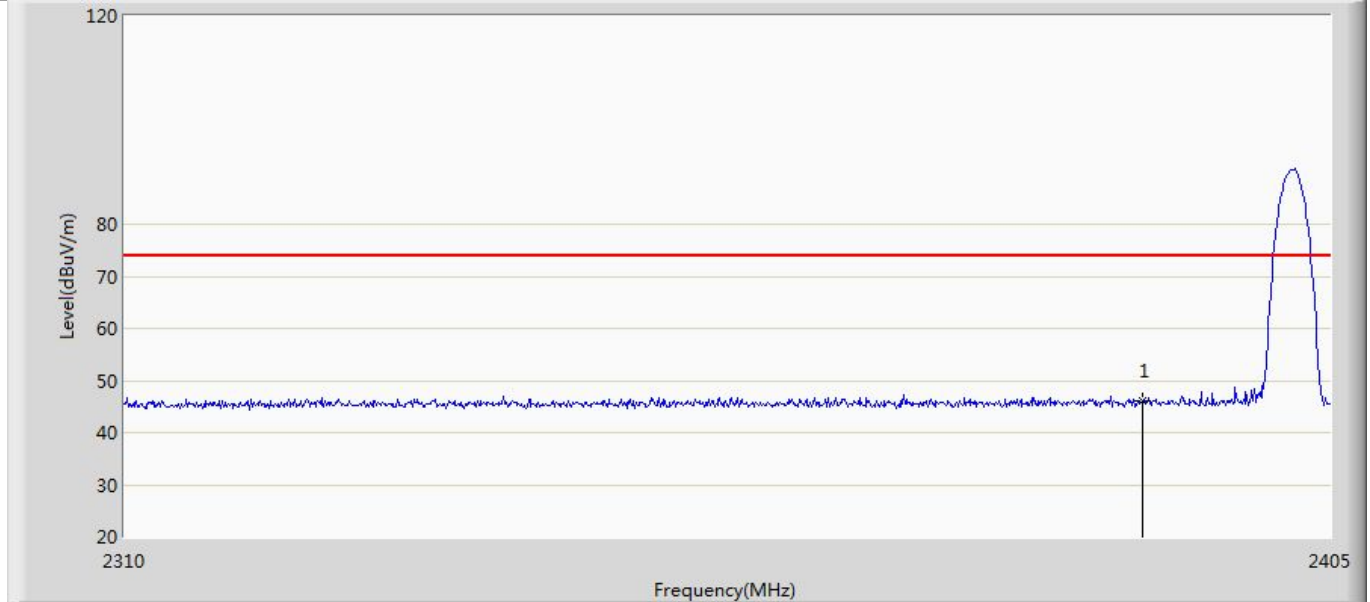

No	Mark	Frequency (MHz)	Measure Level (dBuV/m)	Reading Level (dBuV)	Over Limit (dB)	Limit (dBuV/m)	Factor (dB)	Type
1	*	2390.000	46.223	12.080	-27.777	74.000	34.143	PK

Profile: 2380793R	Page No.: 12
Engineer: Pengchengyang	
Site: AC5	Time: 2023/09/20 - 21:28
Limit: FCC_Part15.209_RE(3m)	Margin: 0
Probe: Horn_3117_00123988(1-18GHz)	Polarity: Vertical
EUT: SKI.WB663U.2	Power: 3.3Vdc
Note: Mode 2: Transmit at 2402MHz by 2DH5	

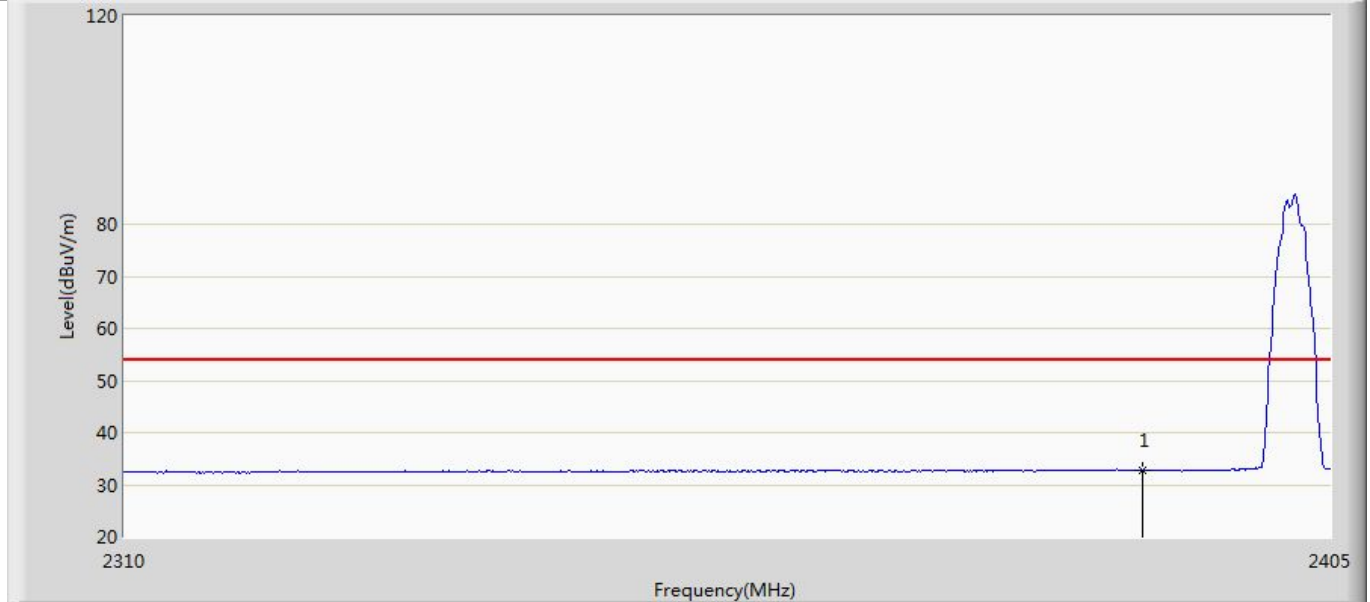

No	Mark	Frequency (MHz)	Measure Level (dBuV/m)	Reading Level (dBuV)	Over Limit (dB)	Limit (dBuV/m)	Factor (dB)	Type
1	*	2390.000	32.681	-1.462	-21.319	54.000	34.143	AV

Profile: 2380793R	Page No.: 13
Engineer: Pengchengyang	
Site: AC5	Time: 2023/09/20 - 21:29
Limit: FCC_Part15.209_RE(3m)	Margin: 0
Probe: Horn_3117_00123988(1-18GHz)	Polarity: Horizontal
EUT: SKI.WB663U.2	Power: 3.3Vdc
Note: Mode 2: Transmit at 2480MHz by 2DH5	

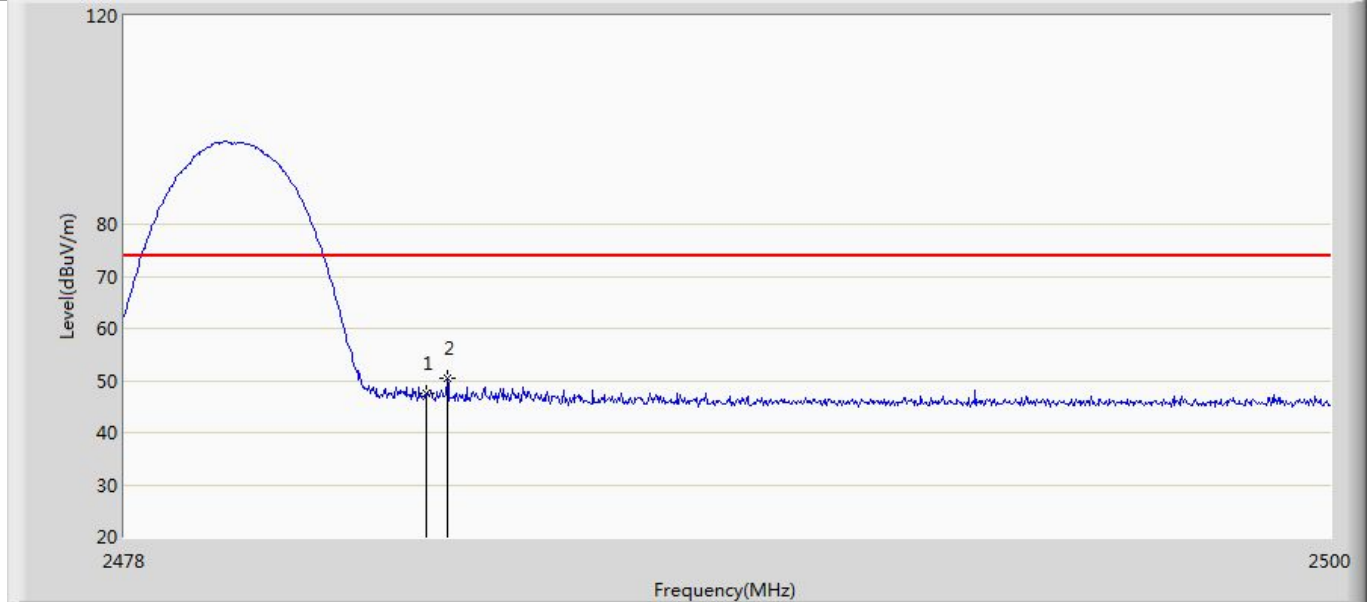

No	Mark	Frequency (MHz)	Measure Level (dBuV/m)	Reading Level (dBuV)	Over Limit (dB)	Limit (dBuV/m)	Factor (dB)	Type
1		2483.500	47.658	13.376	-26.342	74.000	34.282	PK
2	*	2483.874	50.498	16.217	-23.502	74.000	34.281	PK

Profile: 2380793R	Page No.: 14
Engineer: Pengchengyang	
Site: AC5	Time: 2023/09/20 - 21:31
Limit: FCC_Part15.209_RE(3m)	Margin: 0
Probe: Horn_3117_00123988(1-18GHz)	Polarity: Horizontal
EUT: SKI.WB663U.2	Power: 3.3Vdc
Note: Mode 2: Transmit at 2480MHz by 2DH5	

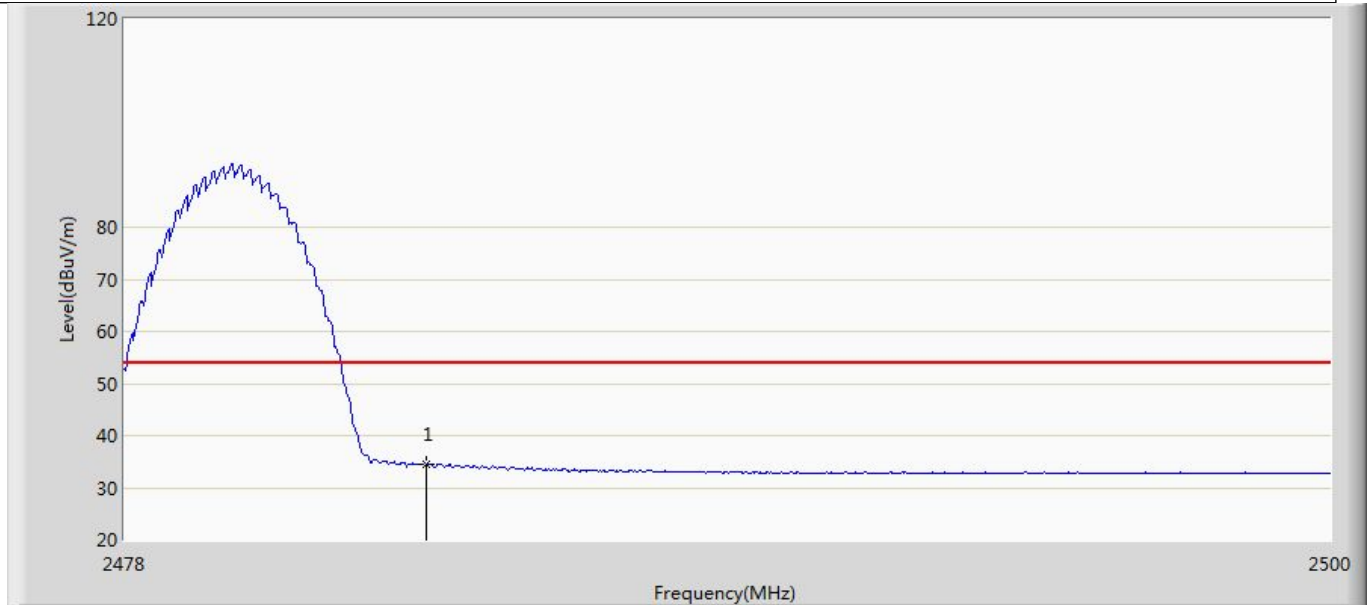

No	Mark	Frequency (MHz)	Measure Level (dBuV/m)	Reading Level (dBuV)	Over Limit (dB)	Limit (dBuV/m)	Factor (dB)	Type
1	*	2483.500	34.356	0.074	-19.644	54.000	34.282	AV

Profile: 2380793R	Page No.: 15
Engineer: Pengchengyang	
Site: AC5	Time: 2023/09/20 - 21:32
Limit: FCC_Part15.209_RE(3m)	Margin: 0
Probe: Horn_3117_00123988(1-18GHz)	Polarity: Vertical
EUT: SKI.WB663U.2	Power: 3.3Vdc
Note: Mode 2: Transmit at 2480MHz by 2DH5	

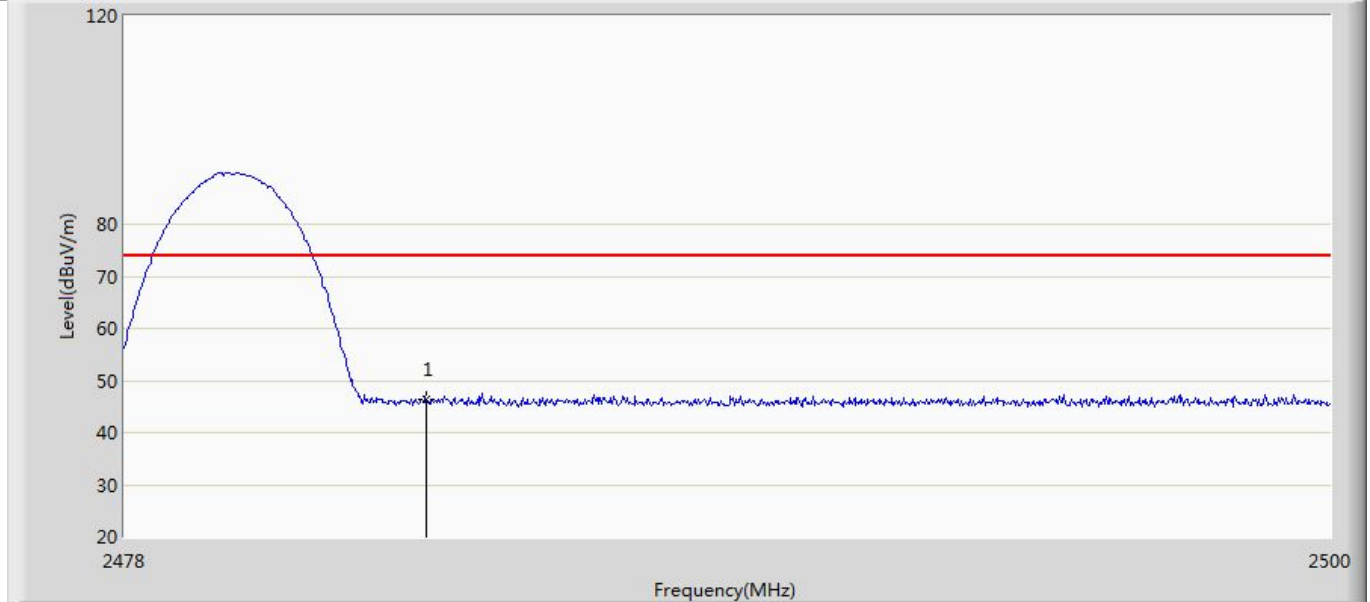

No	Mark	Frequency (MHz)	Measure Level (dBuV/m)	Reading Level (dBuV)	Over Limit (dB)	Limit (dBuV/m)	Factor (dB)	Type
1	*	2483.500	46.497	12.215	-27.503	74.000	34.282	PK

Profile: 2380793R	Page No.: 16
Engineer: Pengchengyang	
Site: AC5	Time: 2023/09/20 - 21:33
Limit: FCC_Part15.209_RE(3m)	Margin: 0
Probe: Horn_3117_00123988(1-18GHz)	Polarity: Vertical
EUT: SKI.WB663U.2	Power: 3.3Vdc
Note: Mode 2: Transmit at 2480MHz by 2DH5	

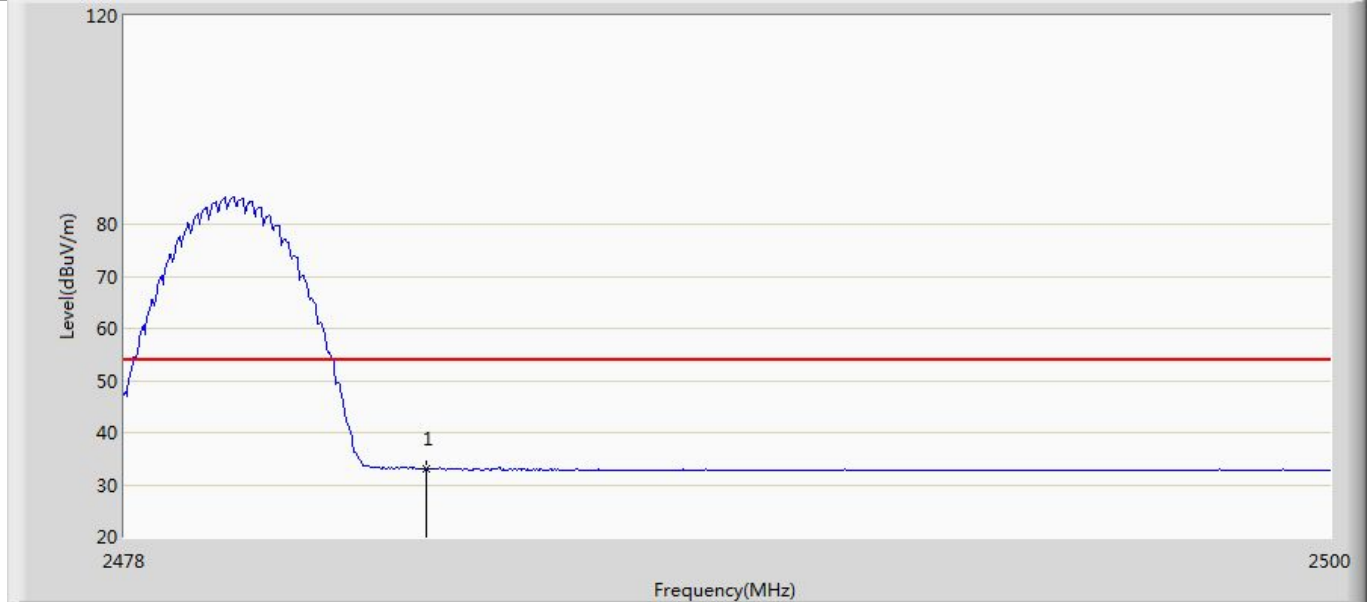

No	Mark	Frequency (MHz)	Measure Level (dBuV/m)	Reading Level (dBuV)	Over Limit (dB)	Limit (dBuV/m)	Factor (dB)	Type
1	*	2483.500	33.068	-1.214	-20.932	54.000	34.282	AV

Profile: 2380793R	Page No.: 17
Engineer: Pengchengyang	
Site: AC5	Time: 2023/09/20 - 21:34
Limit: FCC_Part15.209_RE(3m)	Margin: 0
Probe: Horn_3117_00123988(1-18GHz)	Polarity: Horizontal
EUT: SKI.WB663U.2	Power: 3.3Vdc
Note: Mode 3: Transmit at 2402MHz by 3DH5	

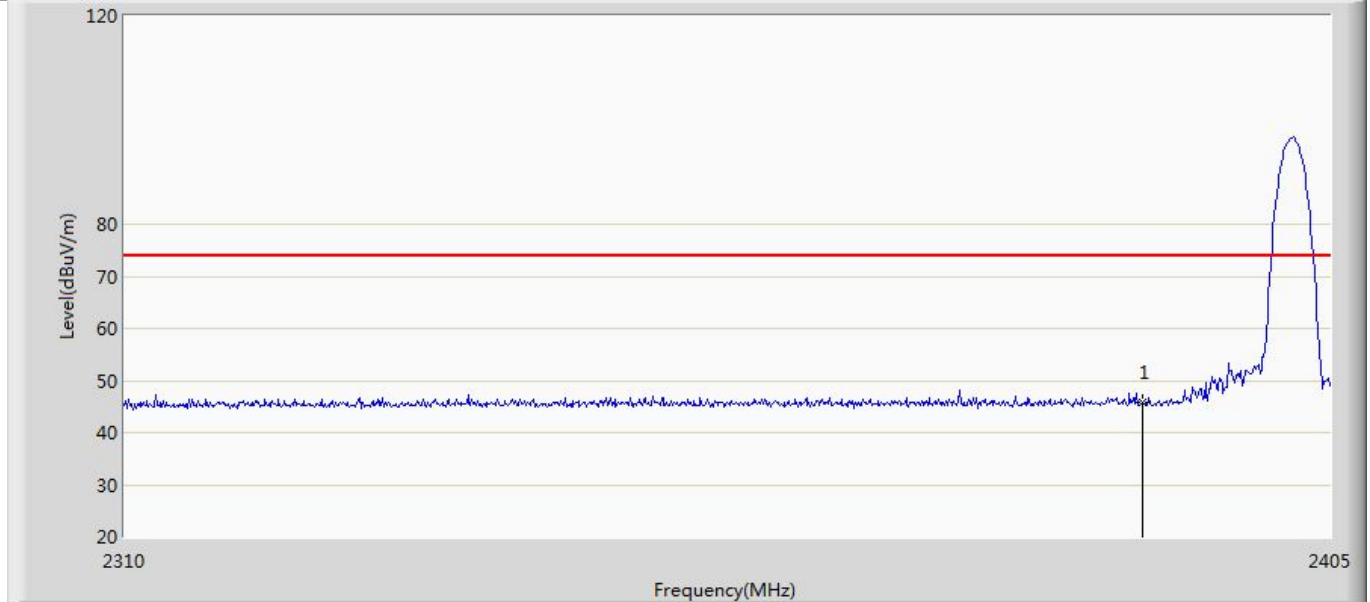

No	Mark	Frequency (MHz)	Measure Level (dBuV/m)	Reading Level (dBuV)	Over Limit (dB)	Limit (dBuV/m)	Factor (dB)	Type
1	*	2390.000	45.851	11.708	-28.149	74.000	34.143	PK

Profile: 2380793R	Page No.: 18
Engineer: Pengchengyang	
Site: AC5	Time: 2023/09/20 - 21:35
Limit: FCC_Part15.209_RE(3m)	Margin: 0
Probe: Horn_3117_00123988(1-18GHz)	Polarity: Horizontal
EUT: SKI.WB663U.2	Power: 3.3Vdc
Note: Mode 3: Transmit at 2402MHz by 3DH5	

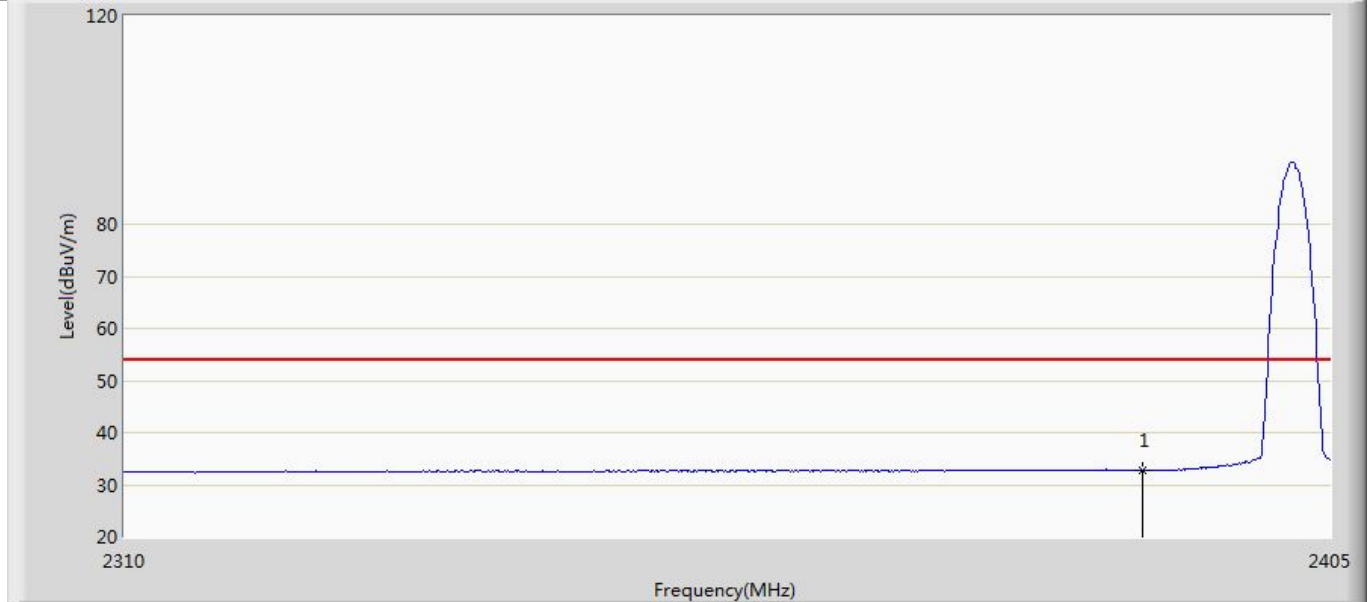

No	Mark	Frequency (MHz)	Measure Level (dBuV/m)	Reading Level (dBuV)	Over Limit (dB)	Limit (dBuV/m)	Factor (dB)	Type
1	*	2390.000	32.808	-1.335	-21.192	54.000	34.143	AV

Profile: 2380793R	Page No.: 19
Engineer: Pengchengyang	
Site: AC5	Time: 2023/09/20 - 21:36
Limit: FCC_Part15.209_RE(3m)	Margin: 0
Probe: Horn_3117_00123988(1-18GHz)	Polarity: Vertical
EUT: SKI.WB663U.2	Power: 3.3Vdc
Note: Mode 3: Transmit at 2402MHz by 3DH5	

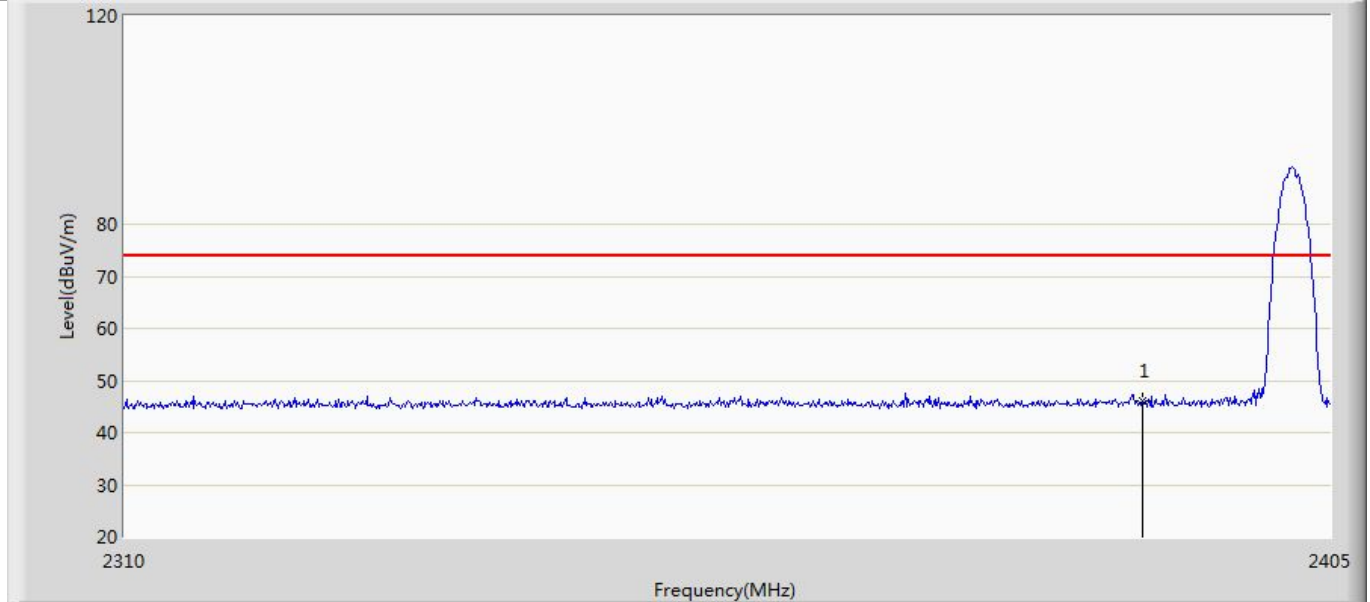

No	Mark	Frequency (MHz)	Measure Level (dBuV/m)	Reading Level (dBuV)	Over Limit (dB)	Limit (dBuV/m)	Factor (dB)	Type
1	*	2390.000	46.044	11.901	-27.956	74.000	34.143	PK

Profile: 2380793R	Page No.: 20
Engineer: Pengchengyang	
Site: AC5	Time: 2023/09/20 - 21:37
Limit: FCC_Part15.209_RE(3m)	Margin: 0
Probe: Horn_3117_00123988(1-18GHz)	Polarity: Vertical
EUT: SKI.WB663U.2	Power: 3.3Vdc
Note: Mode 3: Transmit at 2402MHz by 3DH5	

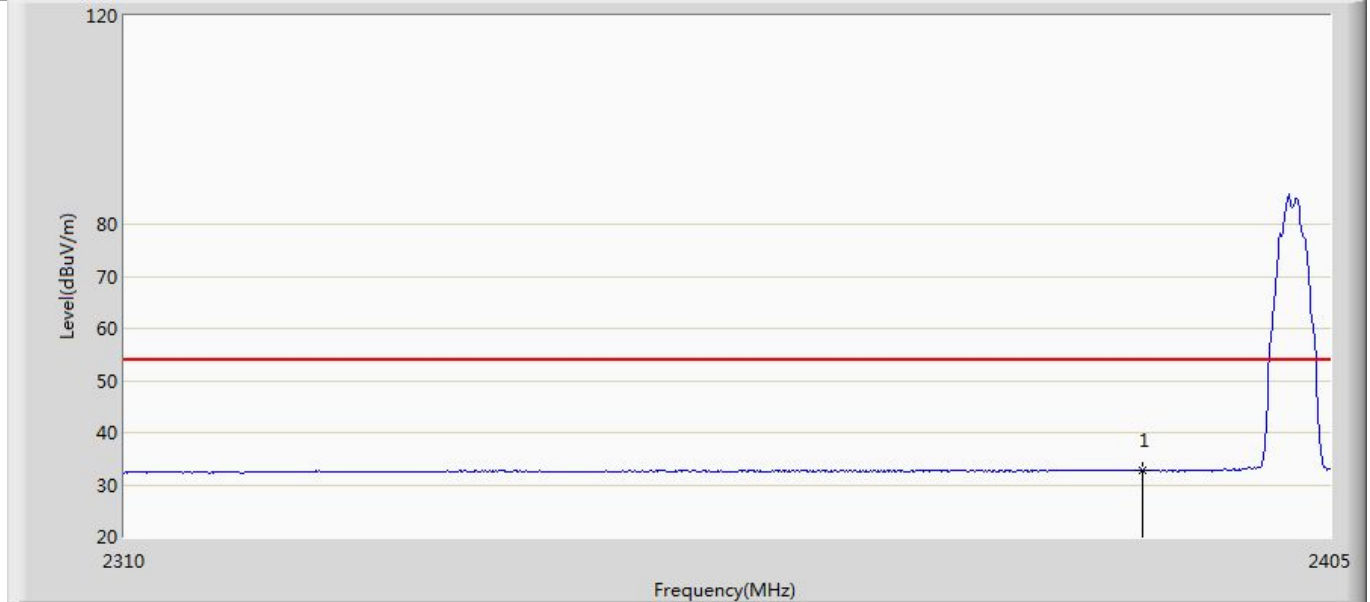

No	Mark	Frequency (MHz)	Measure Level (dBuV/m)	Reading Level (dBuV)	Over Limit (dB)	Limit (dBuV/m)	Factor (dB)	Type
1	*	2390.000	32.686	-1.457	-21.314	54.000	34.143	AV

Profile: 2380793R	Page No.: 21
Engineer: Pengchengyang	
Site: AC5	Time: 2023/09/20 - 21:38
Limit: FCC_Part15.209_RE(3m)	Margin: 0
Probe: Horn_3117_00123988(1-18GHz)	Polarity: Horizontal
EUT: SKI.WB663U.2	Power: 3.3Vdc
Note: Mode 3: Transmit at 2480MHz by 3DH5	

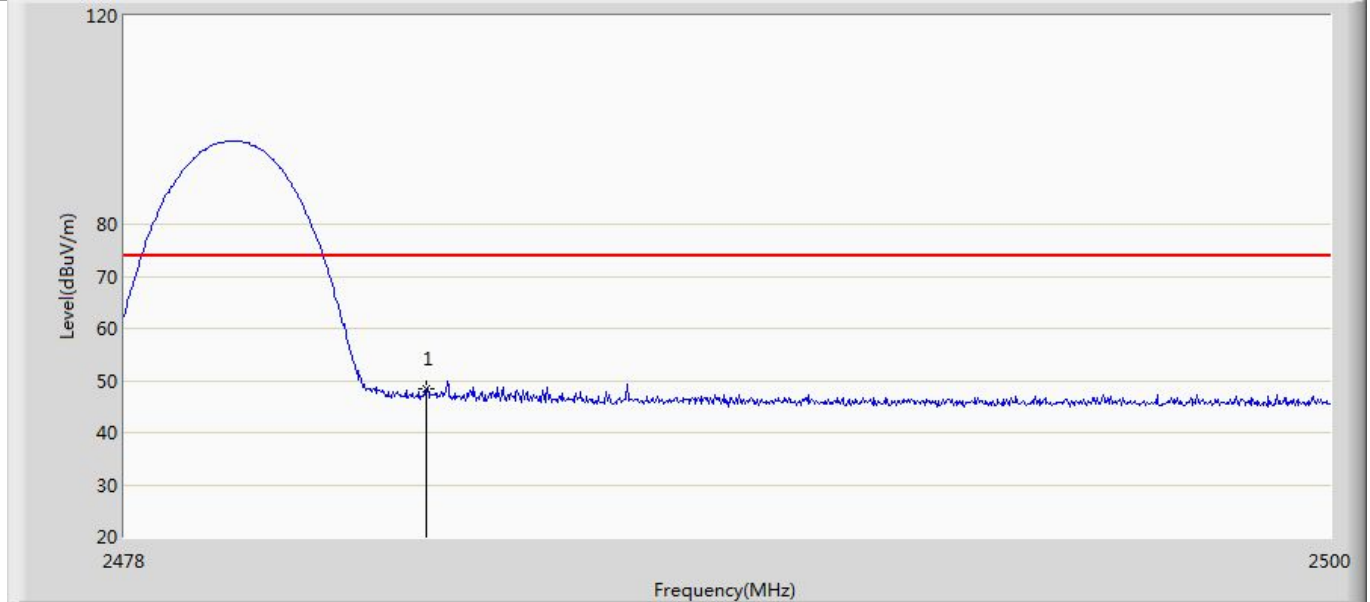

No	Mark	Frequency (MHz)	Measure Level (dBuV/m)	Reading Level (dBuV)	Over Limit (dB)	Limit (dBuV/m)	Factor (dB)	Type
1	*	2483.500	48.273	13.991	-25.727	74.000	34.282	PK

Profile: 2380793R	Page No.: 22
Engineer: Pengchengyang	
Site: AC5	Time: 2023/09/20 - 21:39
Limit: FCC_Part15.209_RE(3m)	Margin: 0
Probe: Horn_3117_00123988(1-18GHz)	Polarity: Horizontal
EUT: SKI.WB663U.2	Power: 3.3Vdc
Note: Mode 3: Transmit at 2480MHz by 3DH5	

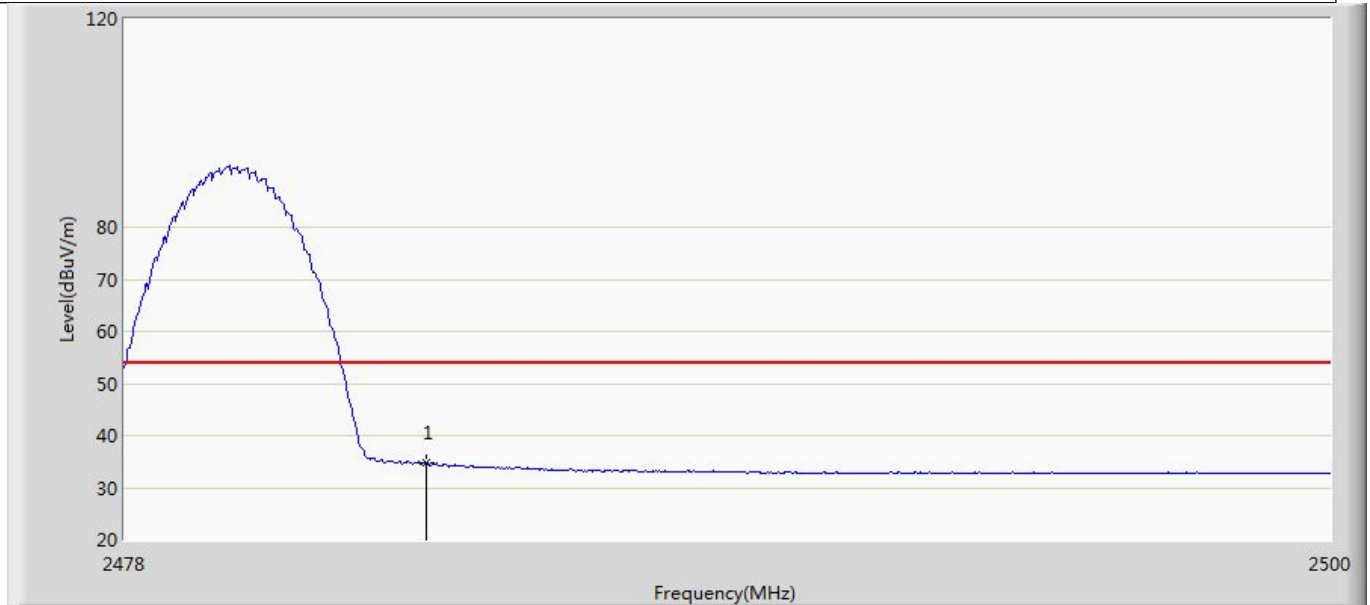

No	Mark	Frequency (MHz)	Measure Level (dBuV/m)	Reading Level (dBuV)	Over Limit (dB)	Limit (dBuV/m)	Factor (dB)	Type
1	*	2483.500	34.690	0.408	-19.310	54.000	34.282	AV

Profile: 2380793R	Page No.: 23
Engineer: Pengchengyang	
Site: AC5	Time: 2023/09/20 - 21:40
Limit: FCC_Part15.209_RE(3m)	Margin: 0
Probe: Horn_3117_00123988(1-18GHz)	Polarity: Vertical
EUT: SKI.WB663U.2	Power: 3.3Vdc
Note: Mode 3: Transmit at 2480MHz by 3DH5	

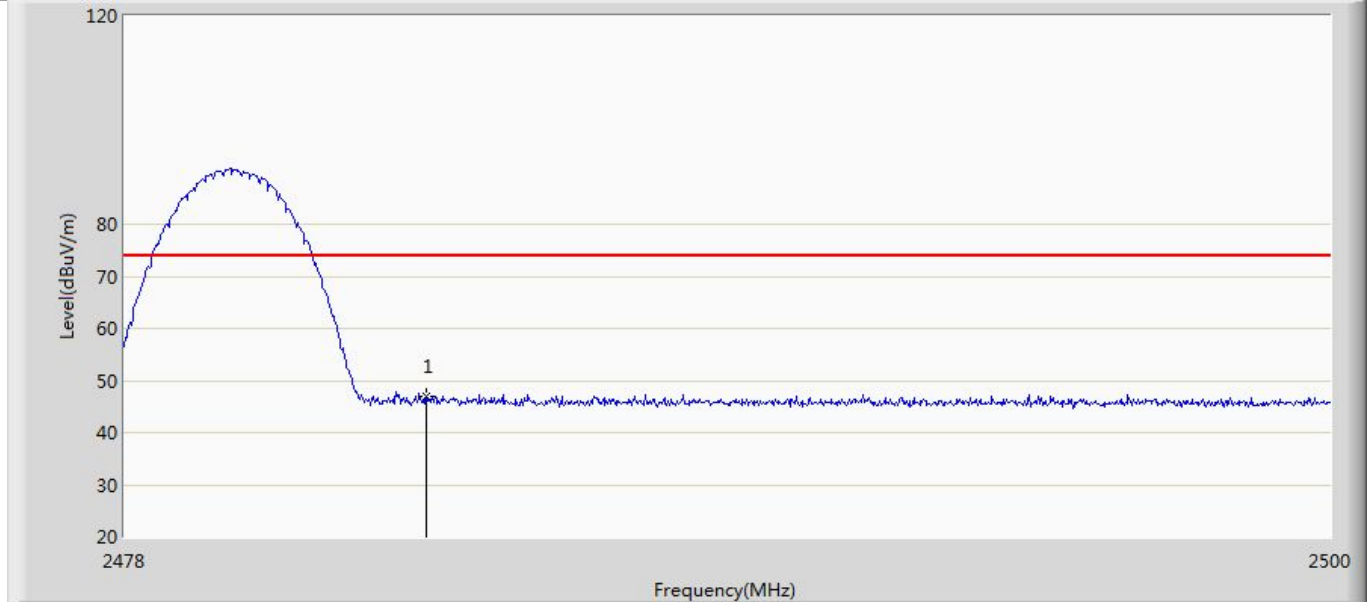

No	Mark	Frequency (MHz)	Measure Level (dBuV/m)	Reading Level (dBuV)	Over Limit (dB)	Limit (dBuV/m)	Factor (dB)	Type
1	*	2483.500	47.015	12.733	-26.985	74.000	34.282	PK

Profile: 2380793R	Page No.: 24
Engineer: Pengchengyang	
Site: AC5	Time: 2023/09/20 - 21:41
Limit: FCC_Part15.209_RE(3m)	Margin: 0
Probe: Horn_3117_00123988(1-18GHz)	Polarity: Vertical
EUT: SKI.WB663U.2	Power: 3.3Vdc
Note: Mode 3: Transmit at 2480MHz by 3DH5	

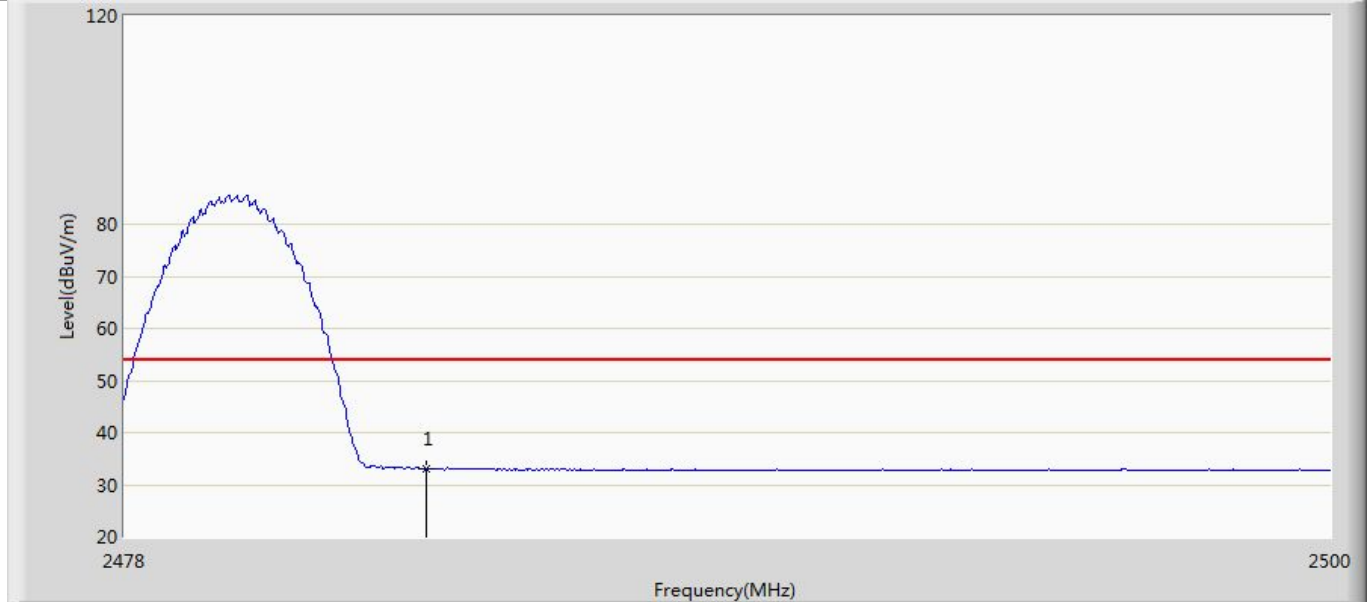

No	Mark	Frequency (MHz)	Measure Level (dBuV/m)	Reading Level (dBuV)	Over Limit (dB)	Limit (dBuV/m)	Factor (dB)	Type
1	*	2483.500	33.181	-1.101	-20.819	54.000	34.282	AV

Note:

1. " * ", means this data is the worst emission level.
2. Measurement Level = Reading Level + Factor(Probe+Cable-Amp). Test Photograph.

Appendix C: Emissions in Restricted Bands

Profile: 2380793R	Page No.: 19
Engineer: Pengchengyang	
Site: AC5	Time: 2023/09/20 - 13:32
Limit: FCC_Part15.209_RE(3m)	Margin: 0
Probe: Horn_3117_00123988(1-18GHz)	Polarity: Horizontal
EUT: SKI.WB663U.2	Power: 3.3Vdc
Note: Mode 1: Transmit at 2402MHz by DH5	

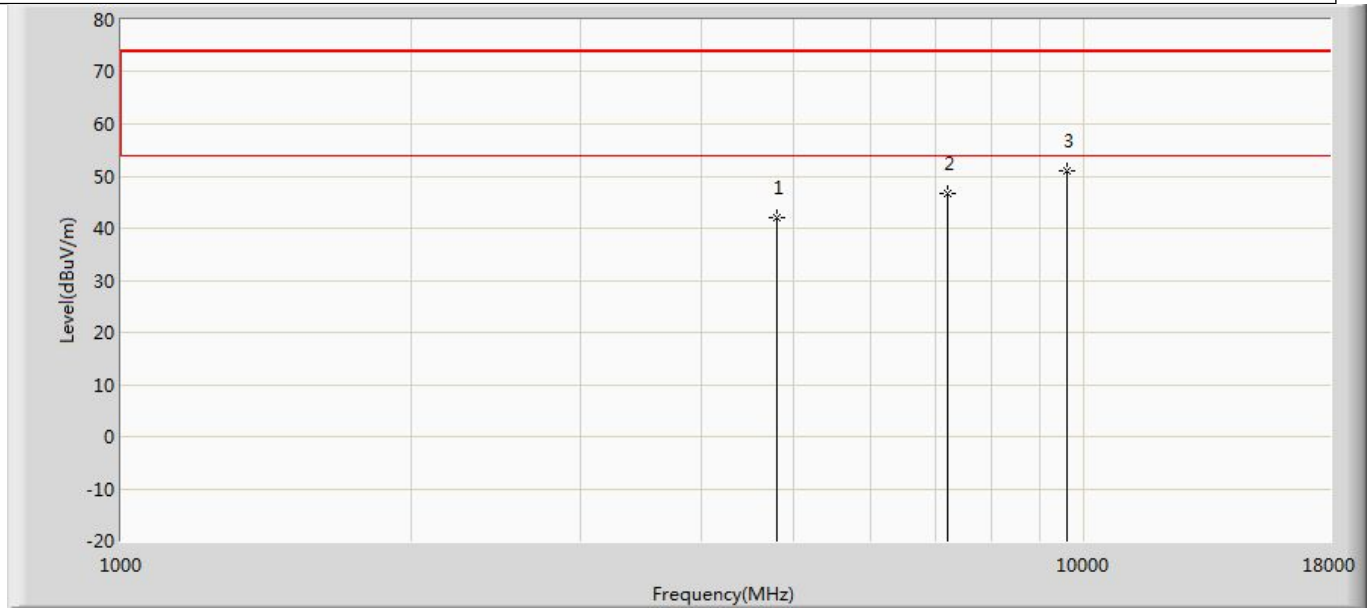

No	Mark	Frequency (MHz)	Measure Level (dBuV/m)	Reading Level (dBuV)	Over Limit (dB)	Limit (dBuV/m)	Factor (dB)	Type
1		4804.000	42.062	56.313	-31.938	74.000	-14.251	PK
2		7206.000	46.616	55.006	-27.384	74.000	-8.390	PK
3	*	9608.000	50.873	54.436	-23.127	74.000	-3.563	PK

Profile: 2380793R	Page No.: 20
Engineer: Pengchengyang	
Site: AC5	Time: 2023/09/20 - 13:32
Limit: FCC_Part15.209_RE(3m)	Margin: 0
Probe: Horn_3117_00123988(1-18GHz)	Polarity: Vertical
EUT: SKI.WB663U.2	Power: 3.3Vdc
Note: Mode 1: Transmit at 2402MHz by DH5	

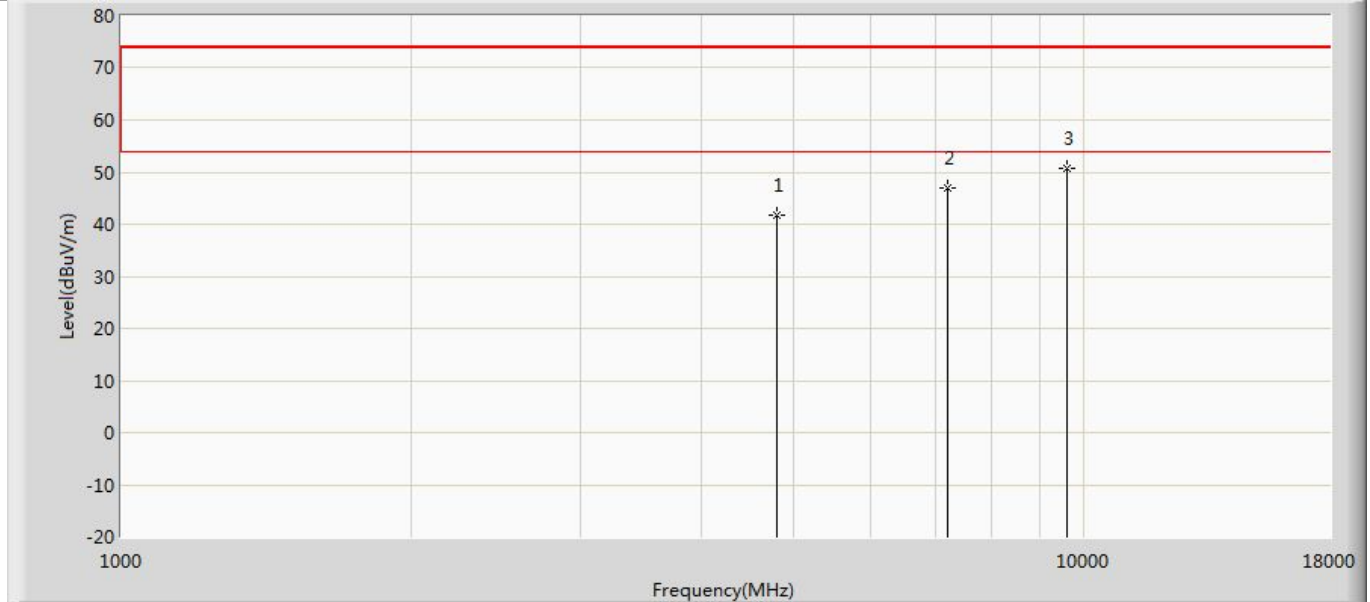

No	Mark	Frequency (MHz)	Measure Level (dBuV/m)	Reading Level (dBuV)	Over Limit (dB)	Limit (dBuV/m)	Factor (dB)	Type
1		4804.000	41.643	55.894	-32.357	74.000	-14.251	PK
2		7206.000	46.972	55.362	-27.028	74.000	-8.390	PK
3	*	9608.000	50.796	54.359	-23.204	74.000	-3.563	PK

Profile: 2380793R	Page No.: 21
Engineer: Pengchengyang	
Site: AC5	Time: 2023/09/20 - 13:32
Limit: FCC_Part15.209_RE(3m)	Margin: 0
Probe: Horn_3117_00123988(1-18GHz)	Polarity: Horizontal
EUT: SKI.WB663U.2	Power: 3.3Vdc
Note: Mode 1: Transmit at 2441MHz by DH5	

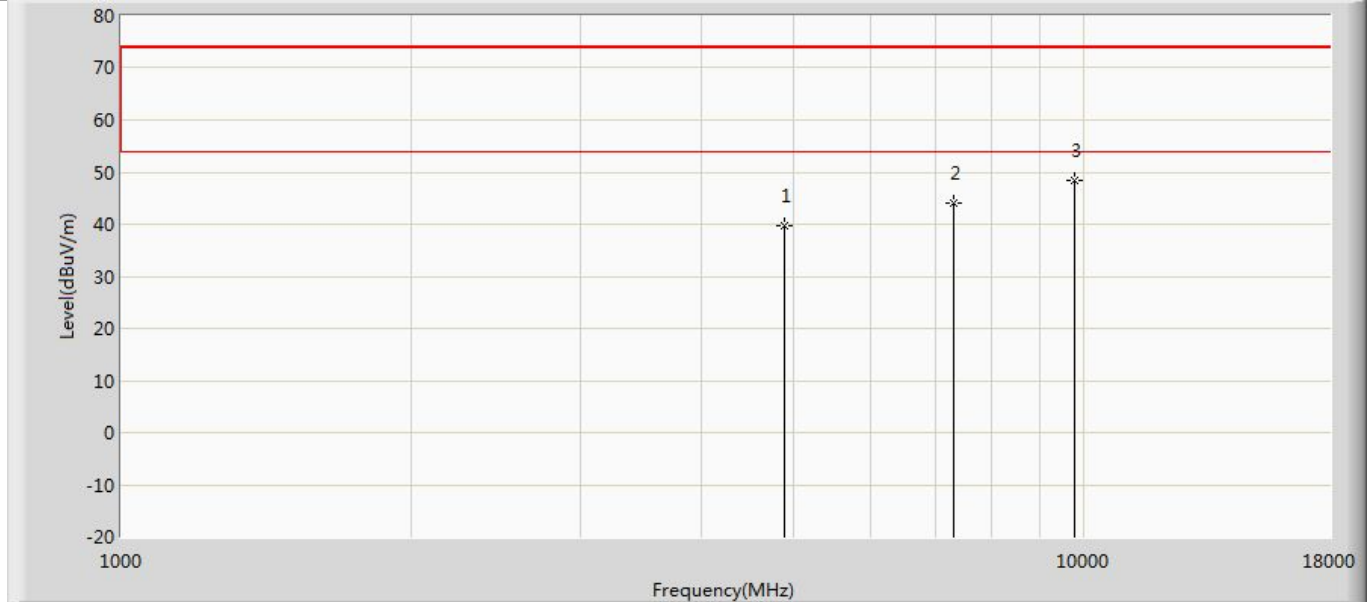

No	Mark	Frequency (MHz)	Measure Level (dBuV/m)	Reading Level (dBuV)	Over Limit (dB)	Limit (dBuV/m)	Factor (dB)	Type
1		4882.000	39.587	53.487	-34.413	74.000	-13.900	PK
2		7323.000	44.048	52.475	-29.952	74.000	-8.427	PK
3	*	9764.000	48.300	51.980	-25.700	74.000	-3.679	PK

Profile: 2380793R	Page No.: 22
Engineer: Pengchengyang	
Site: AC5	Time: 2023/09/20 - 13:32
Limit: FCC_Part15.209_RE(3m)	Margin: 0
Probe: Horn_3117_00123988(1-18GHz)	Polarity: Vertical
EUT: SKI.WB663U.2	Power: 3.3Vdc
Note: Mode 1: Transmit at 2441MHz by DH5	

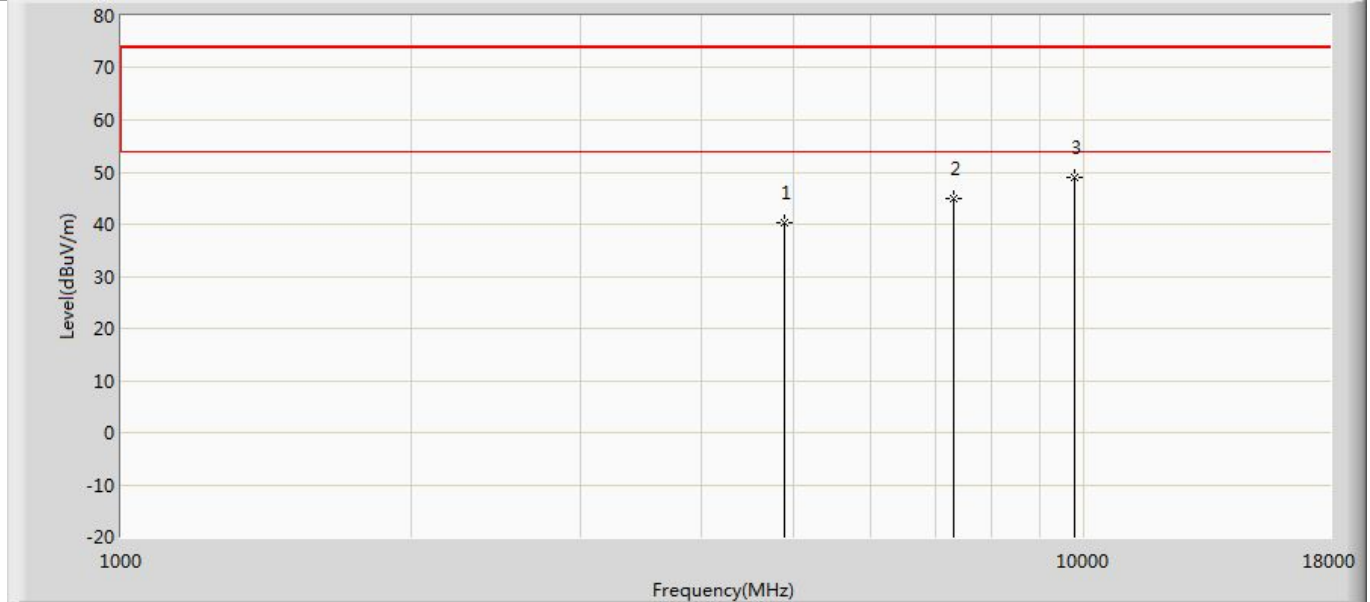

No	Mark	Frequency (MHz)	Measure Level (dBuV/m)	Reading Level (dBuV)	Over Limit (dB)	Limit (dBuV/m)	Factor (dB)	Type
1		4882.000	40.308	54.208	-33.692	74.000	-13.900	PK
2		7323.000	44.827	53.254	-29.173	74.000	-8.427	PK
3	*	9764.000	48.923	52.603	-25.077	74.000	-3.679	PK

Profile: 2380793R	Page No.: 23
Engineer: Pengchengyang	
Site: AC5	Time: 2023/09/20 - 13:32
Limit: FCC_Part15.209_RE(3m)	Margin: 0
Probe: Horn_3117_00123988(1-18GHz)	Polarity: Horizontal
EUT: SKI.WB663U.2	Power: 3.3Vdc
Note: Mode 1: Transmit at 2480MHz by DH5	

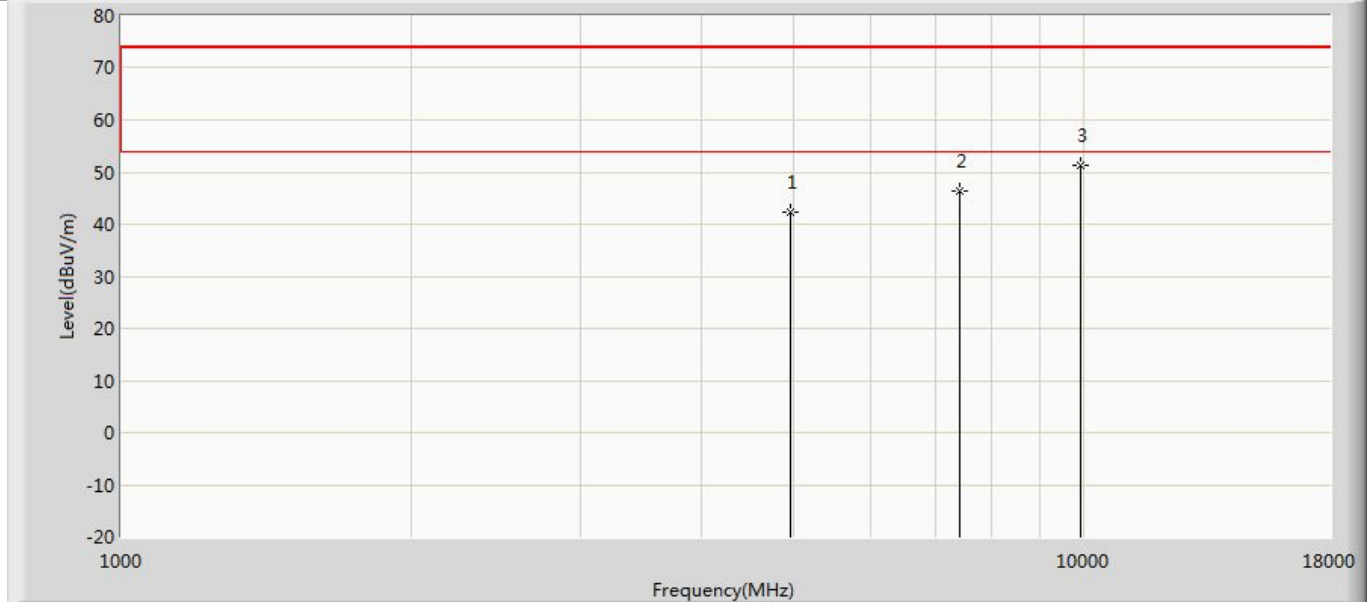

No	Mark	Frequency (MHz)	Measure Level (dBuV/m)	Reading Level (dBuV)	Over Limit (dB)	Limit (dBuV/m)	Factor (dB)	Type
1		4960.000	42.348	56.193	-31.652	74.000	-13.845	PK
2		7440.000	46.467	54.498	-27.533	74.000	-8.031	PK
3	*	9920.000	51.204	54.376	-22.796	74.000	-3.172	PK

Profile: 2380793R	Page No.: 24
Engineer: Pengchengyang	
Site: AC5	Time: 2023/09/20 - 13:32
Limit: FCC_Part15.209_RE(3m)	Margin: 0
Probe: Horn_3117_00123988(1-18GHz)	Polarity: Vertical
EUT: SKI.WB663U.2	Power: 3.3Vdc
Note: Mode 1: Transmit at 2480MHz by DH5	

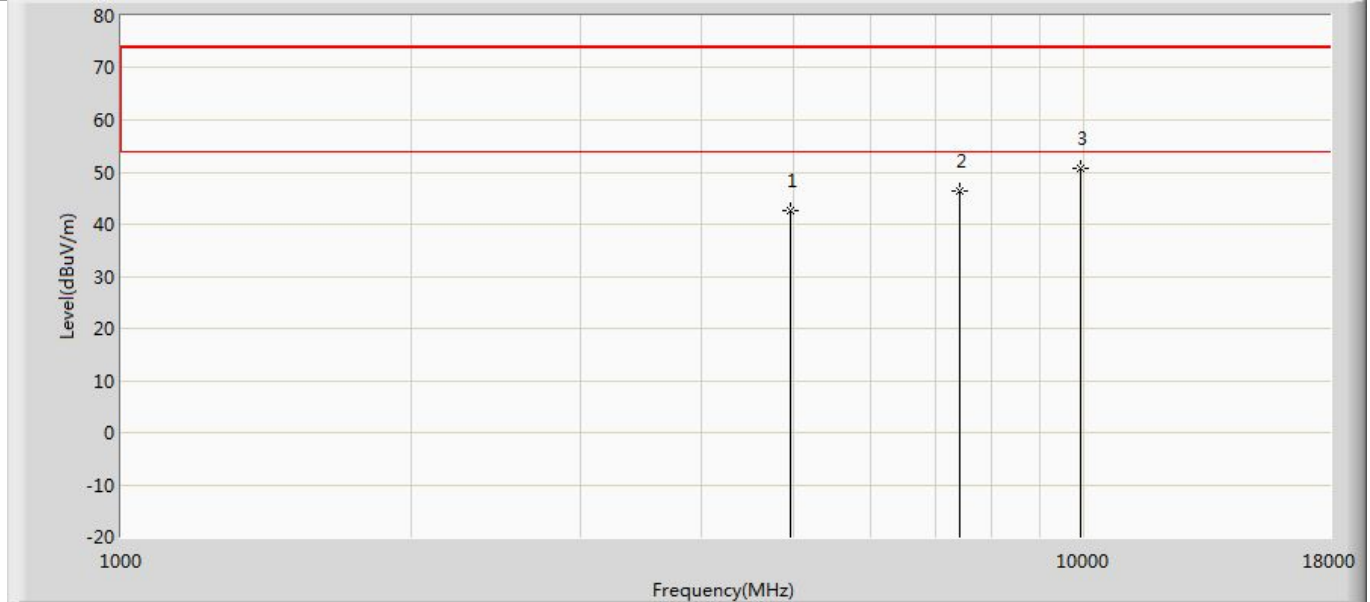

No	Mark	Frequency (MHz)	Measure Level (dBuV/m)	Reading Level (dBuV)	Over Limit (dB)	Limit (dBuV/m)	Factor (dB)	Type
1		4960.000	42.624	56.469	-31.376	74.000	-13.845	PK
2		7440.000	46.509	54.540	-27.491	74.000	-8.031	PK
3	*	9920.000	50.617	53.789	-23.383	74.000	-3.172	PK

Profile: 2380793R	Page No.: 25
Engineer: Pengchengyang	
Site: AC5	Time: 2023/09/20 - 13:32
Limit: FCC_Part15.209_RE(3m)	Margin: 0
Probe: Horn_3117_00123988(1-18GHz)	Polarity: Horizontal
EUT: SKI.WB663U.2	Power: 3.3Vdc
Note: Mode 2: Transmit at 2402MHz by 2DH5	

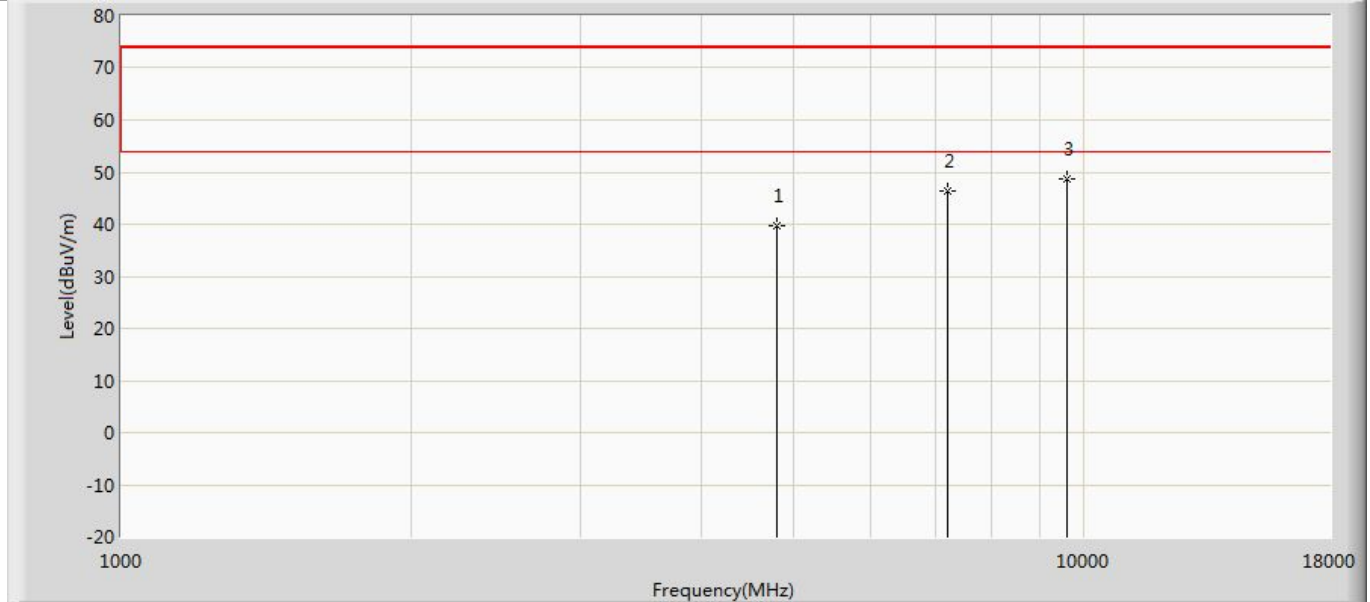

No	Mark	Frequency (MHz)	Measure Level (dBuV/m)	Reading Level (dBuV)	Over Limit (dB)	Limit (dBuV/m)	Factor (dB)	Type
1		4804.000	39.633	53.884	-34.367	74.000	-14.251	PK
2		7206.000	46.326	54.716	-27.674	74.000	-8.390	PK
3	*	9608.000	48.638	52.201	-25.362	74.000	-3.563	PK

Profile: 2380793R	Page No.: 26
Engineer: Pengchengyang	
Site: AC5	Time: 2023/09/20 - 13:33
Limit: FCC_Part15.209_RE(3m)	Margin: 0
Probe: Horn_3117_00123988(1-18GHz)	Polarity: Vertical
EUT: SKI.WB663U.2	Power: 3.3Vdc
Note: Mode 2: Transmit at 2402MHz by 2DH5	

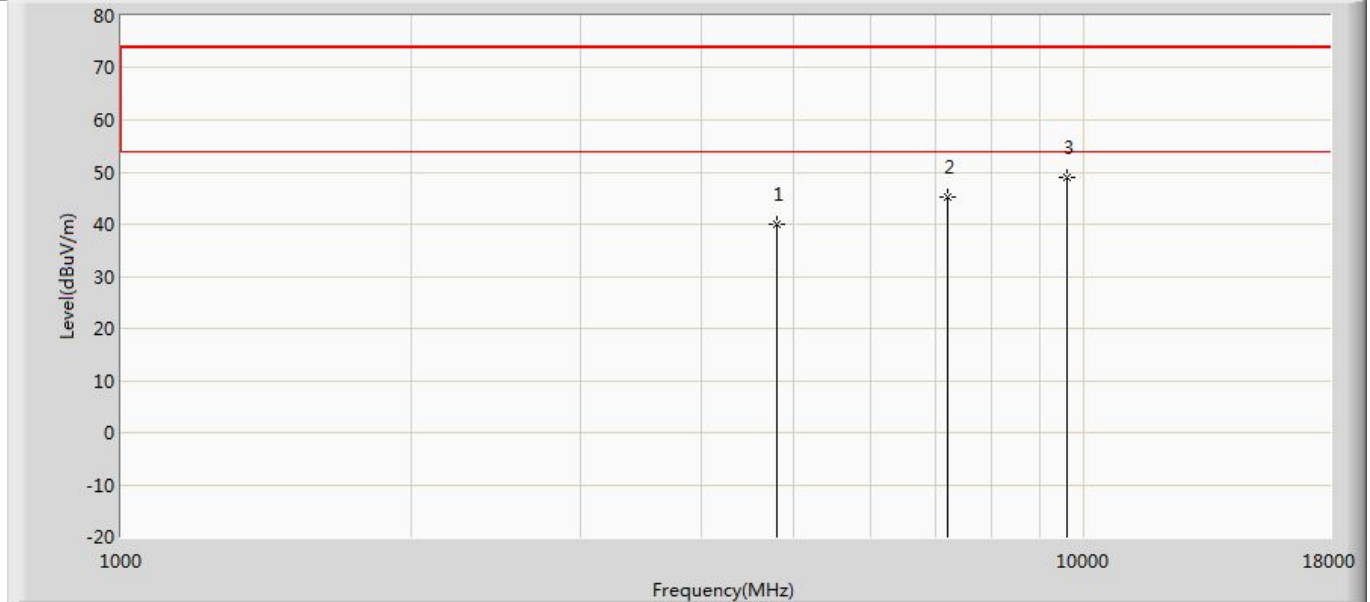

No	Mark	Frequency (MHz)	Measure Level (dBuV/m)	Reading Level (dBuV)	Over Limit (dB)	Limit (dBuV/m)	Factor (dB)	Type
1		4804.000	39.965	54.216	-34.035	74.000	-14.251	PK
2		7206.000	45.130	53.520	-28.870	74.000	-8.390	PK
3	*	9608.000	48.962	52.525	-25.038	74.000	-3.563	PK

Profile: 2380793R	Page No.: 27
Engineer: Pengchengyang	
Site: AC5	Time: 2023/09/20 - 13:33
Limit: FCC_Part15.209_RE(3m)	Margin: 0
Probe: Horn_3117_00123988(1-18GHz)	Polarity: Horizontal
EUT: SKI.WB663U.2	Power: 3.3Vdc
Note: Mode 2: Transmit at 2441MHz by 2DH5	

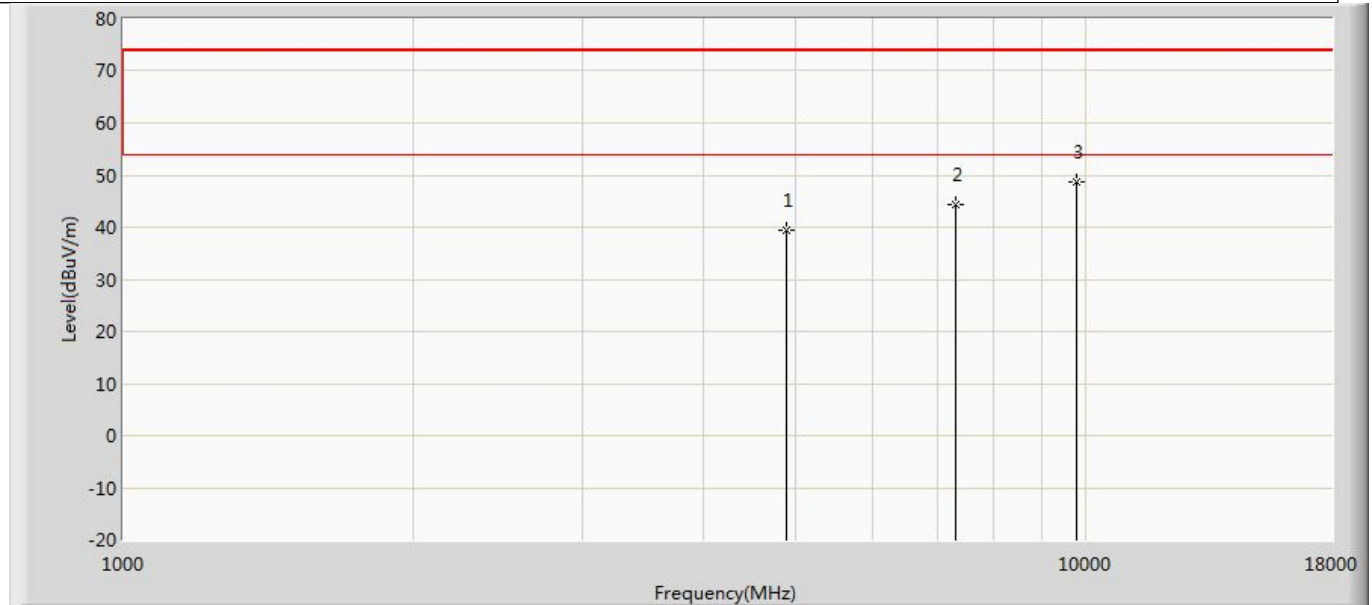

No	Mark	Frequency (MHz)	Measure Level (dBuV/m)	Reading Level (dBuV)	Over Limit (dB)	Limit (dBuV/m)	Factor (dB)	Type
1		4882.000	39.294	53.194	-34.706	74.000	-13.900	PK
2		7323.000	44.379	52.806	-29.621	74.000	-8.427	PK
3	*	9764.000	48.626	52.306	-25.374	74.000	-3.679	PK

Profile: 2380793R	Page No.: 28
Engineer: Pengchengyang	
Site: AC5	Time: 2023/09/20 - 13:33
Limit: FCC_Part15.209_RE(3m)	Margin: 0
Probe: Horn_3117_00123988(1-18GHz)	Polarity: Vertical
EUT: SKI.WB663U.2	Power: 3.3Vdc
Note: Mode 2: Transmit at 2441MHz by 2DH5	

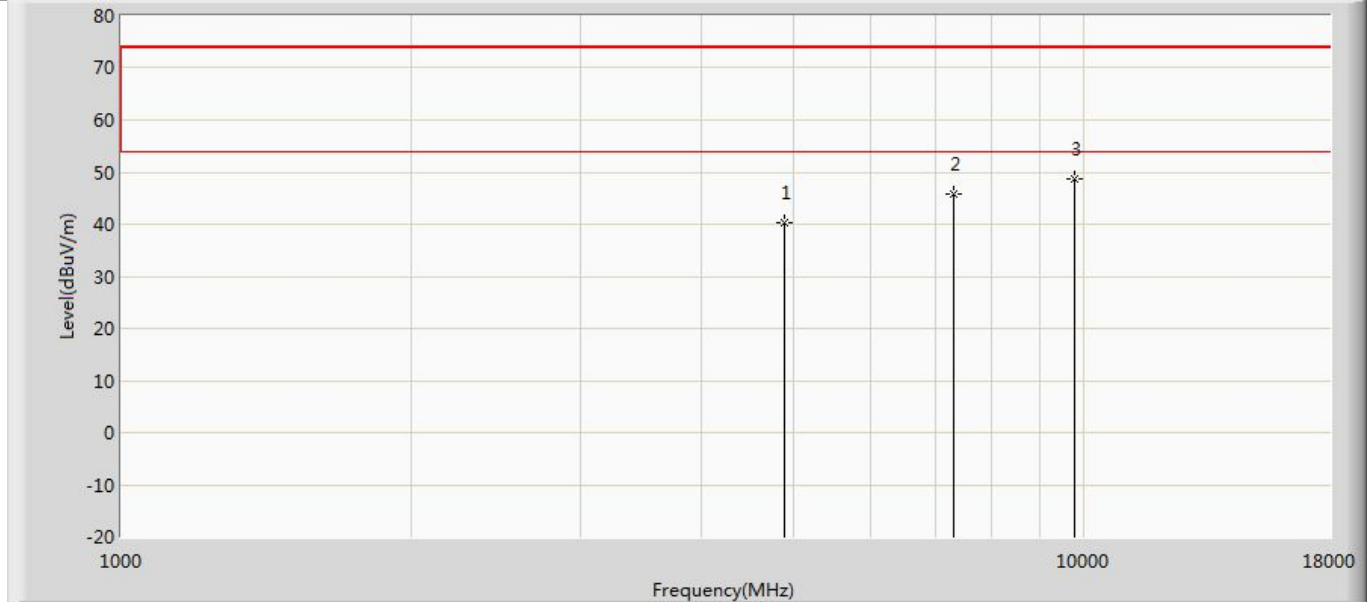

No	Mark	Frequency (MHz)	Measure Level (dBuV/m)	Reading Level (dBuV)	Over Limit (dB)	Limit (dBuV/m)	Factor (dB)	Type
1		4882.000	40.231	54.131	-33.769	74.000	-13.900	PK
2		7323.000	45.713	54.140	-28.287	74.000	-8.427	PK
3	*	9764.000	48.784	52.464	-25.216	74.000	-3.679	PK

Profile: 2380793R	Page No.: 29
Engineer: Pengchengyang	
Site: AC5	Time: 2023/09/20 - 13:33
Limit: FCC_Part15.209_RE(3m)	Margin: 0
Probe: Horn_3117_00123988(1-18GHz)	Polarity: Horizontal
EUT: SKI.WB663U.2	Power: 3.3Vdc
Note: Mode 2: Transmit at 2480MHz by 2DH5	

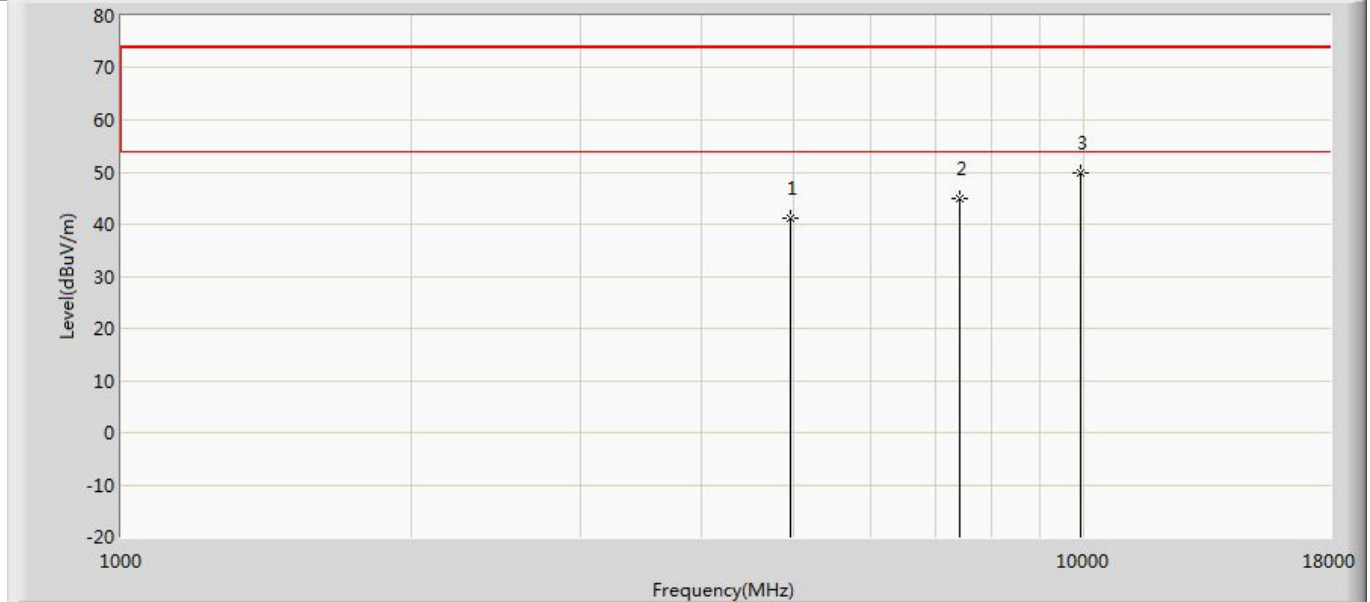

No	Mark	Frequency (MHz)	Measure Level (dBuV/m)	Reading Level (dBuV)	Over Limit (dB)	Limit (dBuV/m)	Factor (dB)	Type
1		4960.000	41.243	55.088	-32.757	74.000	-13.845	PK
2		7440.000	44.837	52.868	-29.163	74.000	-8.031	PK
3	*	9920.000	49.915	53.087	-24.085	74.000	-3.172	PK

Profile: 2380793R	Page No.: 30
Engineer: Pengchengyang	
Site: AC5	Time: 2023/09/20 - 13:33
Limit: FCC_Part15.209_RE(3m)	Margin: 0
Probe: Horn_3117_00123988(1-18GHz)	Polarity: Vertical
EUT: SKI.WB663U.2	Power: 3.3Vdc
Note: Mode 2: Transmit at 2480MHz by 2DH5	

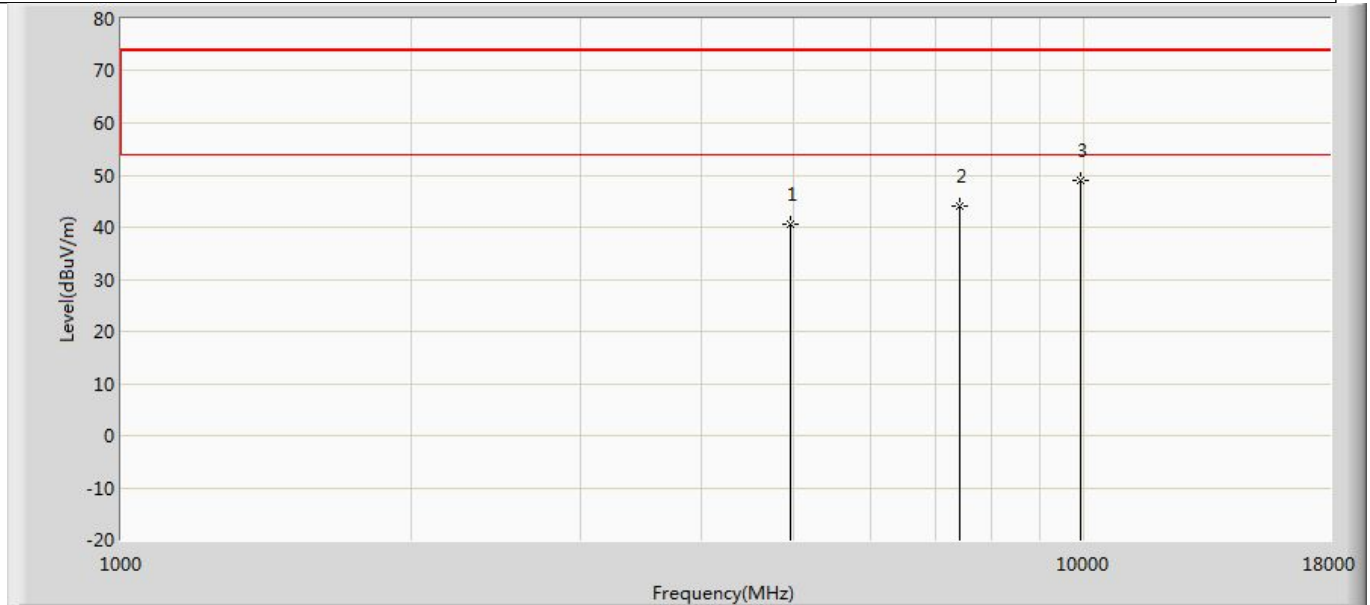

No	Mark	Frequency (MHz)	Measure Level (dBuV/m)	Reading Level (dBuV)	Over Limit (dB)	Limit (dBuV/m)	Factor (dB)	Type
1		4960.000	40.665	54.510	-33.335	74.000	-13.845	PK
2		7440.000	44.048	52.079	-29.952	74.000	-8.031	PK
3	*	9920.000	49.050	52.222	-24.950	74.000	-3.172	PK

Profile: 2380793R	Page No.: 31
Engineer: Pengchengyang	
Site: AC5	Time: 2023/09/20 - 13:33
Limit: FCC_Part15.209_RE(3m)	Margin: 0
Probe: Horn_3117_00123988(1-18GHz)	Polarity: Horizontal
EUT: SKI.WB663U.2	Power: 3.3Vdc
Note: Mode 3: Transmit at 2402MHz by 3DH5	

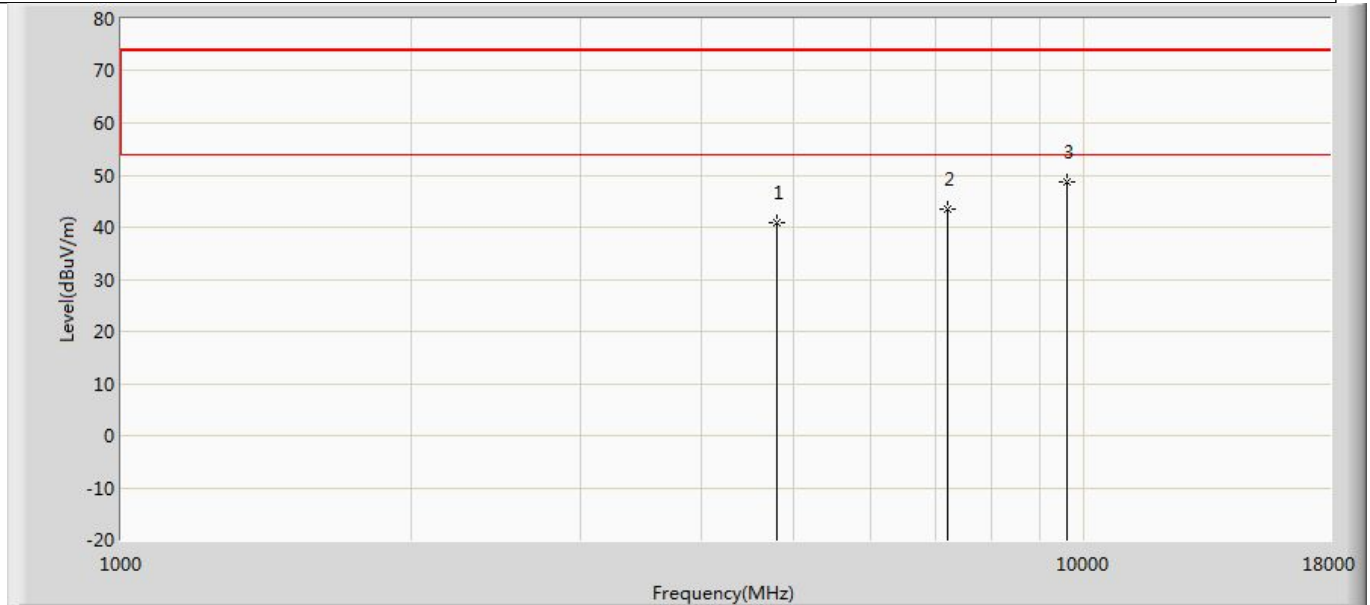

No	Mark	Frequency (MHz)	Measure Level (dBuV/m)	Reading Level (dBuV)	Over Limit (dB)	Limit (dBuV/m)	Factor (dB)	Type
1		4804.000	40.914	55.165	-33.086	74.000	-14.251	PK
2		7206.000	43.335	51.725	-30.665	74.000	-8.390	PK
3	*	9608.000	48.683	52.246	-25.317	74.000	-3.563	PK

Profile: 2380793R	Page No.: 32
Engineer: Pengchengyang	
Site: AC5	Time: 2023/09/20 - 13:33
Limit: FCC_Part15.209_RE(3m)	Margin: 0
Probe: Horn_3117_00123988(1-18GHz)	Polarity: Vertical
EUT: SKI.WB663U.2	Power: 3.3Vdc
Note: Mode 3: Transmit at 2402MHz by 3DH5	

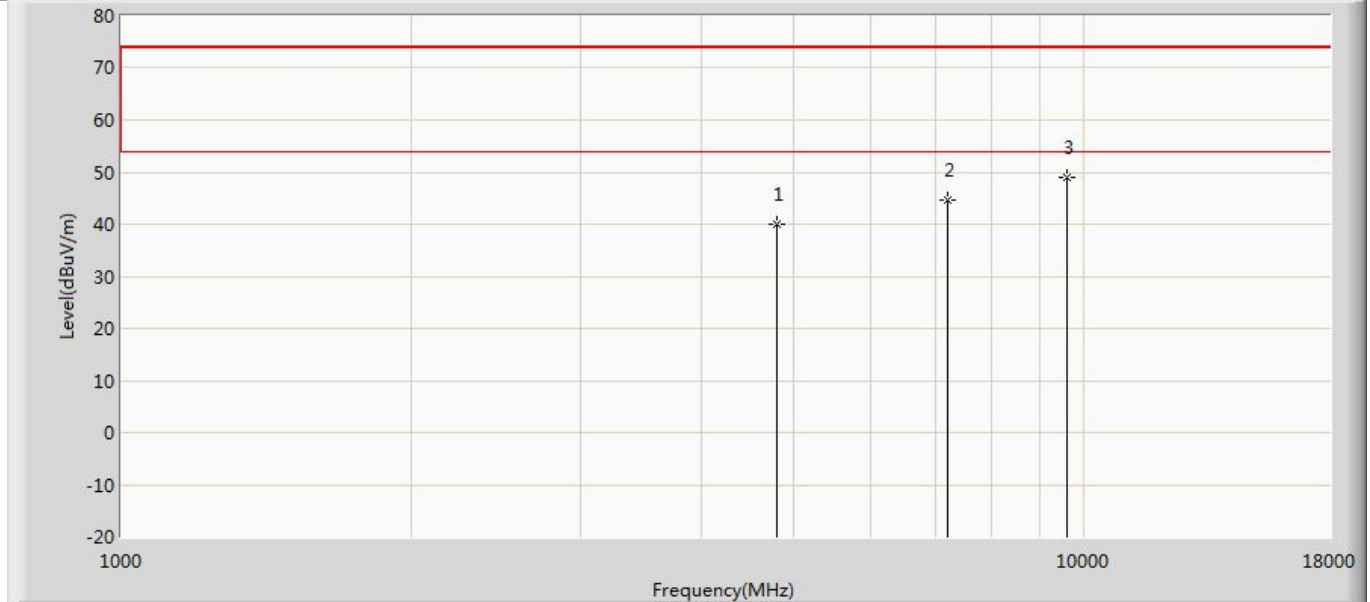

No	Mark	Frequency (MHz)	Measure Level (dBuV/m)	Reading Level (dBuV)	Over Limit (dB)	Limit (dBuV/m)	Factor (dB)	Type
1		4804.000	40.143	54.394	-33.857	74.000	-14.251	PK
2		7206.000	44.616	53.006	-29.384	74.000	-8.390	PK
3	*	9608.000	49.128	52.691	-24.872	74.000	-3.563	PK

Profile: 2380793R	Page No.: 33
Engineer: Pengchengyang	
Site: AC5	Time: 2023/09/20 - 13:33
Limit: FCC_Part15.209_RE(3m)	Margin: 0
Probe: Horn_3117_00123988(1-18GHz)	Polarity: Horizontal
EUT: SKI.WB663U.2	Power: 3.3Vdc
Note: Mode 3: Transmit at 2441MHz by 3DH5	

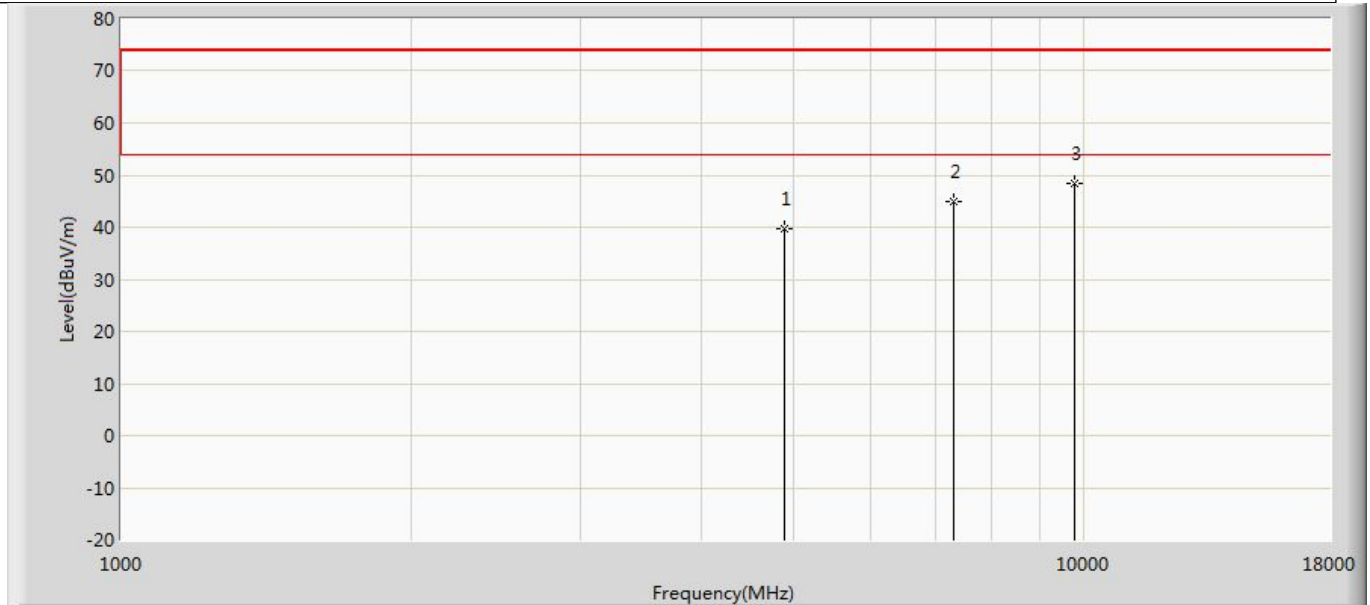

No	Mark	Frequency (MHz)	Measure Level (dBuV/m)	Reading Level (dBuV)	Over Limit (dB)	Limit (dBuV/m)	Factor (dB)	Type
1		4882.000	39.643	53.543	-34.357	74.000	-13.900	PK
2		7323.000	44.934	53.361	-29.066	74.000	-8.427	PK
3	*	9764.000	48.502	52.182	-25.498	74.000	-3.679	PK

Profile: 2380793R	Page No.: 34
Engineer: Pengchengyang	
Site: AC5	Time: 2023/09/20 - 13:33
Limit: FCC_Part15.209_RE(3m)	Margin: 0
Probe: Horn_3117_00123988(1-18GHz)	Polarity: Vertical
EUT: SKI.WB663U.2	Power: 3.3Vdc
Note: Mode 3: Transmit at 2441MHz by 3DH5	

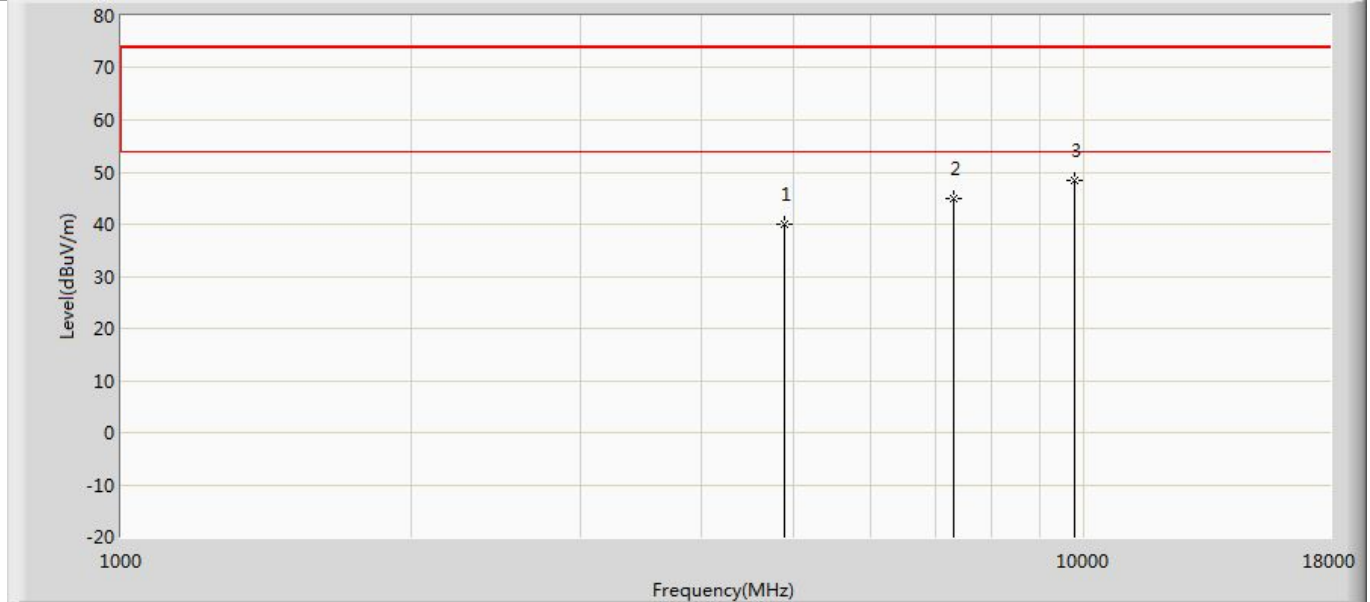

No	Mark	Frequency (MHz)	Measure Level (dBuV/m)	Reading Level (dBuV)	Over Limit (dB)	Limit (dBuV/m)	Factor (dB)	Type
1		4882.000	40.015	53.915	-33.985	74.000	-13.900	PK
2		7323.000	44.909	53.336	-29.091	74.000	-8.427	PK
3	*	9764.000	48.396	52.076	-25.604	74.000	-3.679	PK

Profile: 2380793R	Page No.: 35
Engineer: Pengchengyang	
Site: AC5	Time: 2023/09/20 - 13:33
Limit: FCC_Part15.209_RE(3m)	Margin: 0
Probe: Horn_3117_00123988(1-18GHz)	Polarity: Horizontal
EUT: SKI.WB663U.2	Power: 3.3Vdc
Note: Mode 3: Transmit at 2480MHz by 3DH5	

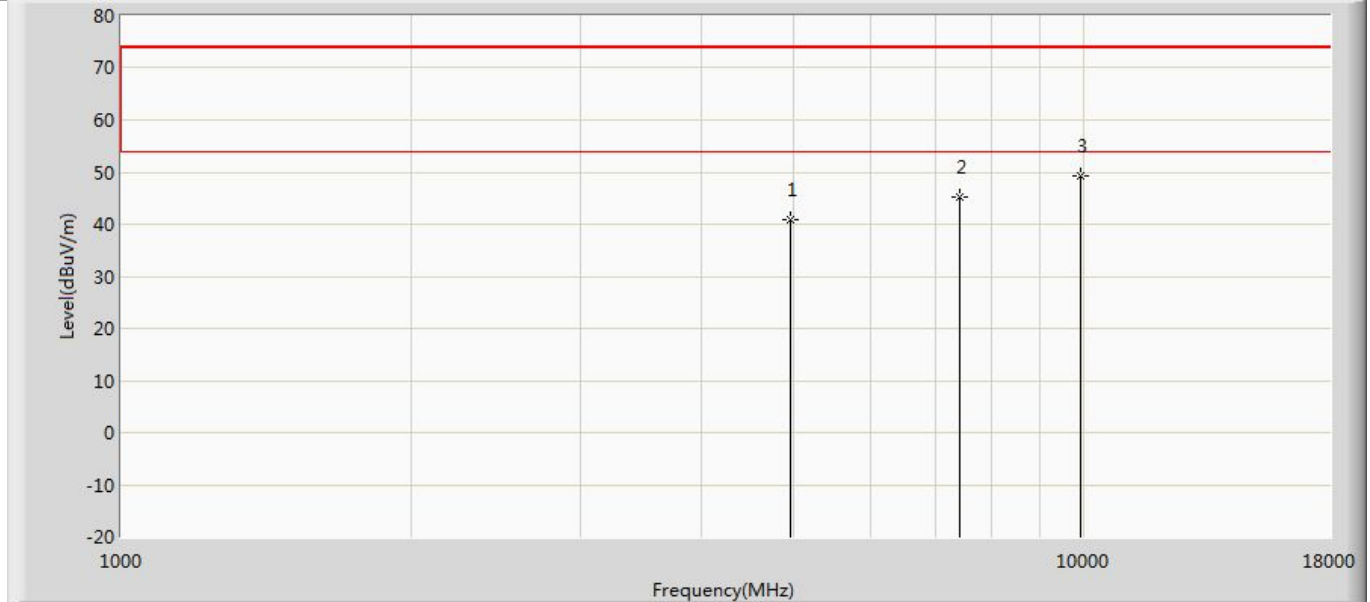

No	Mark	Frequency (MHz)	Measure Level (dBuV/m)	Reading Level (dBuV)	Over Limit (dB)	Limit (dBuV/m)	Factor (dB)	Type
1		4960.000	40.897	54.742	-33.103	74.000	-13.845	PK
2		7440.000	45.294	53.325	-28.706	74.000	-8.031	PK
3	*	9920.000	49.275	52.447	-24.725	74.000	-3.172	PK

Profile: 2380793R	Page No.: 36
Engineer: Pengchengyang	
Site: AC5	Time: 2023/09/20 - 13:33
Limit: FCC_Part15.209_RE(3m)	Margin: 0
Probe: Horn_3117_00123988(1-18GHz)	Polarity: Vertical
EUT: SKI.WB663U.2	Power: 3.3Vdc
Note: Mode 3: Transmit at 2480MHz by 3DH5	

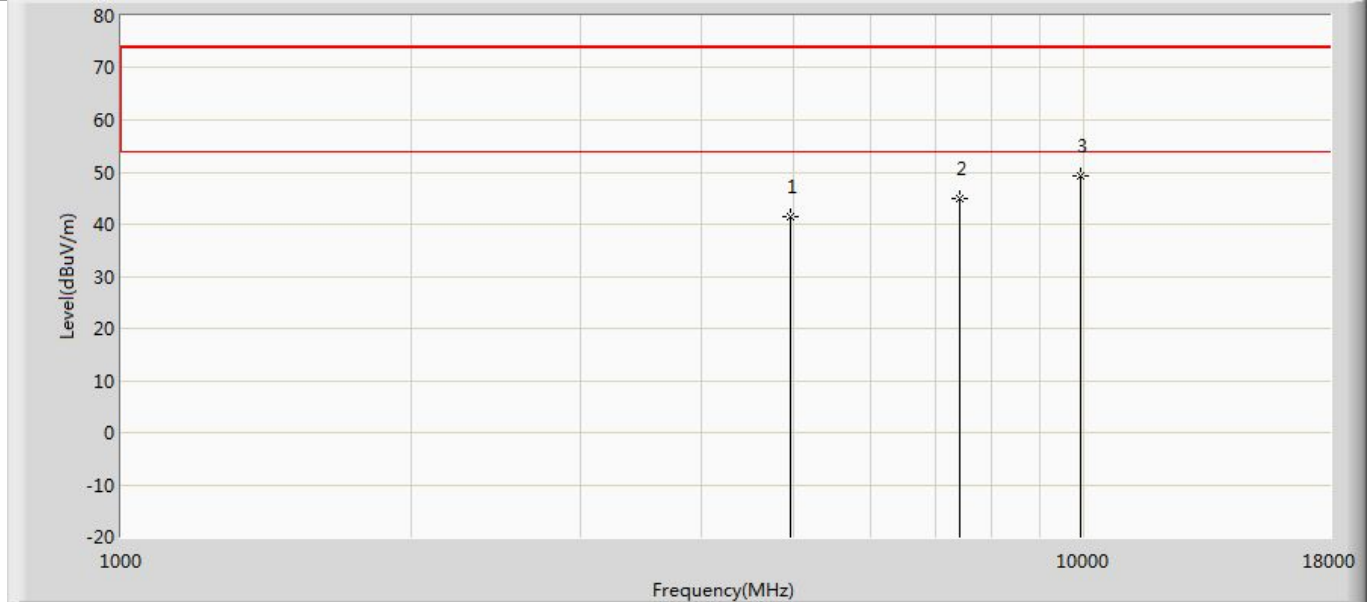

No	Mark	Frequency (MHz)	Measure Level (dBuV/m)	Reading Level (dBuV)	Over Limit (dB)	Limit (dBuV/m)	Factor (dB)	Type
1		4960.000	41.510	55.355	-32.490	74.000	-13.845	PK
2		7440.000	44.947	52.978	-29.053	74.000	-8.031	PK
3	*	9920.000	49.320	52.492	-24.680	74.000	-3.172	PK

Note:

1. " * ", means this data is the worst emission level.
2. Measurement Level = Reading Level + Factor(Probe+Cable-Amp). Test Photograph.

The worst case of radiation emissions in restricted bands below 1GHz:

Profile: 2380793R	Page No.: 25
Engineer: Pengchengyang	
Site: AC2	Time: 2023/09/21 - 12:23
Limit: FCC_Part 15.209_RE (3m)	Margin: 0
Probe: CBL6112B_2933(30-1000MHz)	Polarity: Horizontal
EUT: SKI.WB663U.2	Power: 3.3Vdc
Note: Mode 1: Transmit at 2480MHz by DH5	

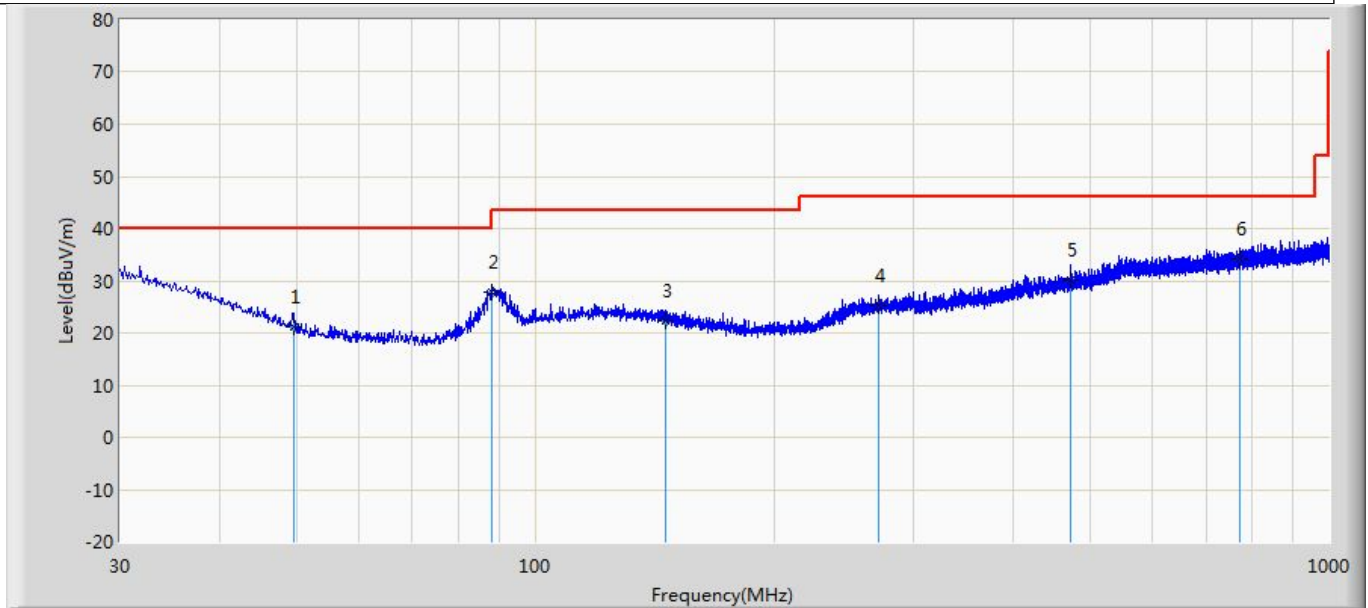

No	Mark	Frequency (MHz)	Measure Level (dBuV/m)	Reading Level (dBuV)	Over Limit (dB)	Limit (dBuV/m)	Factor (dB)	Type
1		49.643	21.179	5.807	-18.821	40.000	15.372	QP
2		88.321	27.840	12.211	-15.660	43.500	15.629	QP
3		146.279	22.284	4.578	-21.216	43.500	17.706	QP
4		270.560	25.210	4.811	-20.790	46.000	20.399	QP
5		472.078	30.289	5.257	-15.711	46.000	25.032	QP
6	*	773.263	34.320	5.534	-11.680	46.000	28.787	QP

Profile: 2380793R	Page No.: 26
Engineer: Pengchengyang	
Site: AC2	Time: 2023/09/21 - 12:24
Limit: FCC_Part 15.209_RE (3m)	Margin: 0
Probe: CBL6112B_2933(30-1000MHz)	Polarity: Vertical
EUT: SKI.WB663U.2	Power: 3.3Vdc
Note: Mode 1: Transmit at 2480MHz by DH5	

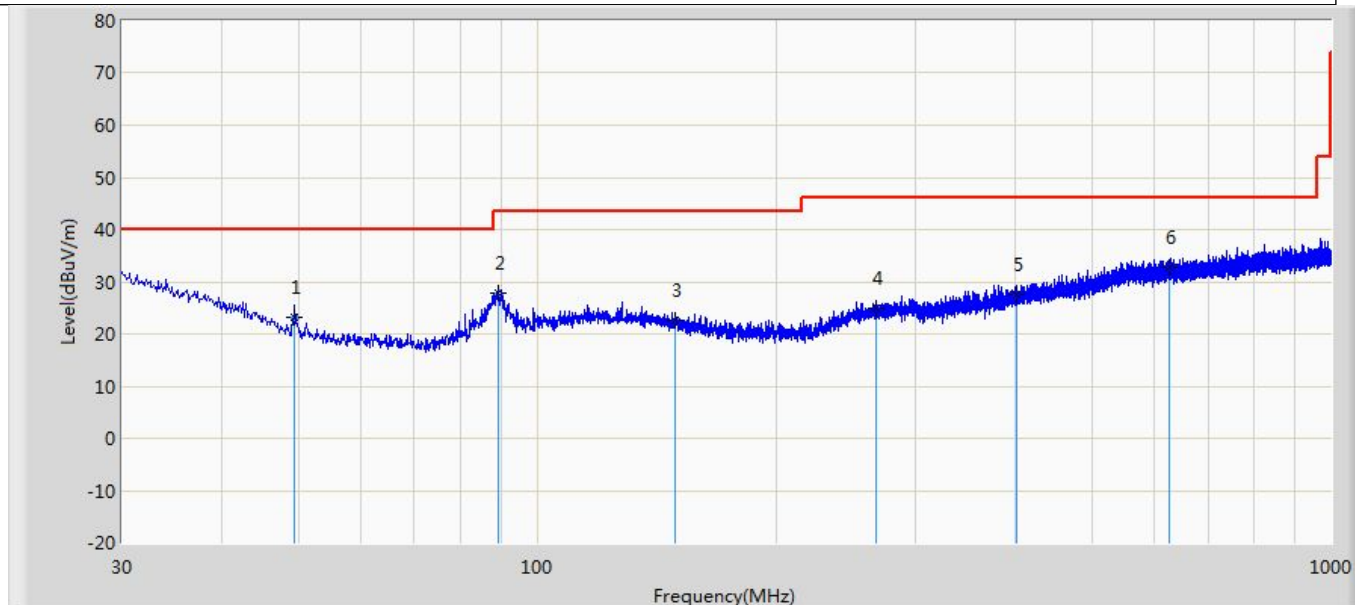

No	Mark	Frequency (MHz)	Measure Level (dBuV/m)	Reading Level (dBuV)	Over Limit (dB)	Limit (dBuV/m)	Factor (dB)	Type
1		49.521	23.245	7.821	-16.755	40.000	15.424	QP
2		89.291	27.920	12.106	-15.580	43.500	15.814	QP
3		149.189	22.500	5.014	-21.000	43.500	17.487	QP
4		267.286	24.840	4.517	-21.160	46.000	20.323	QP
5		401.267	27.533	3.787	-18.467	46.000	23.746	QP
6	*	625.216	32.840	5.335	-13.160	46.000	27.505	QP

Note:

1. " * ", means this data is the worst emission level.

2. Measurement Level = Reading Level + Factor(Probe+Cable-Amp). Test Photograph.

The End