



**CFR 47 FCC PART 15 SUBPART C  
ISED RSS-247 ISSUE 2**

**TEST REPORT**

*For*

**IEEE 802.11a/b/g/n/ac 2T2R USB Wi-Fi Module Integrated Bluetooth 2.1+EDR/4.2/5.1**

**MODEL NUMBER: SKI.WB663U.2**

**REPORT NUMBER: 4790553410-RF-1**

**ISSUE DATE: September 15, 2022**

**FCC ID:2AR82-SKIWB663U21**

**IC:24728-SKIWB663U21**

*Prepared for*

**Guangzhou Shikun Electronics Co., Ltd  
NO.6 Liankun Road, Huangpu District, Guangzhou, China**

*Prepared by*

**UL Verification Services (Guangzhou) Co., Ltd, Song Shan Lake Branch**

**Building 10, Innovation Technology Park, No. 1, Li Bin Road, Song Shan Lake Hi-Tech Development Zone Dongguan, 523808, People's Republic of China**

**Tel: +86 769 22038881**

**Fax: +86 769 33244054**

**Website: [www.ul.com](http://www.ul.com)**

The results reported herein have been performed in accordance with the laboratory's terms of accreditation. This report shall not be reproduced except in full without the written approval of the Laboratory. The results in this report apply to the test sample(s) mentioned above at the time of the testing period only and are not to be used to indicate applicability to other similar products.



Revision History

Rev.	Issue Date	Revisions	Revised By
V0	September 15, 2022	Initial Issue	

Note: This is a C2PC test report. The applicant added three types of antennas and applied for C2PC on December 18, 2021, the antennas information showed in table 1. Now the applicant wants to add one more type of antenna and the antenna information showed in table 2. Spot check had been done for the conducted output power, the power of module remained unchanged, so we retest all radiated band edge and spurious emission and show in this report, for more data and information, please refer to the original report 4790010773.1-1.

Table 1						
Antenna	Antenna Model	Frequency (MHz)	Antenna Type	Cable Loss (dB)	Maximum Antenna Gain without Cable (dBi)	Final Antenna Gain (dBi)
1	INNO-EWFDKT-237	2402-2480	Dipole Antenna	1.5	2.44	0.94
2	A100-0062	2402-2480	Dipole Antenna	1.5	3.17	1.67
3	3D0504BK07-001	2402-2480	Dipole Antenna	1.5	2.97	1.47

Table 2			
Antenna	Frequency (MHz)	Antenna Type	Maximum Antenna Gain (dBi)
1	2402-2480	FPC	2.47

Note: The antenna information showed in table 1 comes from report 4790176872-1.



### Summary of Test Results

Test Item	Clause	Limit/Requirement	Result
Radiated Band edge and Spurious Emission	ANSI C63.10-2013, Clause 11.12 & Clause 11.13	FCC 15.247 (d) FCC 15.209 FCC 15.205 RSS-247 Clause 5.5 RSS-GEN Clause 8.9 RSS-GEN Clause 8.10	Pass

\*This test report is only published to and used by the applicant, and it is not for evidence purpose in China.

\*The measurement result for the sample received is <Pass> according to <CFR 47 FCC PART 15 SUBPART C and ISED RSS-247 ISSUE 2> when <Accuracy Method> decision rule is applied.

## CONTENTS

<b>1. ATTESTATION OF TEST RESULTS.....</b>	<b>5</b>
<b>2. TEST METHODOLOGY.....</b>	<b>6</b>
<b>3. FACILITIES AND ACCREDITATION.....</b>	<b>6</b>
<b>4. CALIBRATION AND UNCERTAINTY .....</b>	<b>7</b>
4.1. <i>MEASURING INSTRUMENT CALIBRATION .....</i>	<i>7</i>
4.2. <i>MEASUREMENT UNCERTAINTY.....</i>	<i>7</i>
<b>5. EQUIPMENT UNDER TEST .....</b>	<b>8</b>
5.1. <i>DESCRIPTION OF EUT .....</i>	<i>8</i>
5.2. <i>CHANNEL LIST .....</i>	<i>8</i>
5.3. <i>MAXIMUM EIRP .....</i>	<i>8</i>
5.4. <i>TEST CHANNEL CONFIGURATION.....</i>	<i>9</i>
5.5. <i>THE WORSE CASE POWER SETTING PARAMETER.....</i>	<i>9</i>
5.6. <i>DESCRIPTION OF AVAILABLE ANTENNAS .....</i>	<i>9</i>
5.7. <i>DESCRIPTION OF TEST SETUP.....</i>	<i>10</i>
<b>6. MEASURING EQUIPMENT AND SOFTWARE USED.....</b>	<b>11</b>
<b>7. ANTENNA PORT TEST RESULTS .....</b>	<b>12</b>
7.1. <i>ON TIME AND DUTY CYCLE.....</i>	<i>12</i>
7.2. <i>PEAK CONDUCTED OUTPUT POWER.....</i>	<i>14</i>
<b>8. RADIATED TEST RESULTS.....</b>	<b>16</b>
8.1. <i>RESTRICTED BANDEDGE .....</i>	<i>25</i>
8.2. <i>SPURIOUS EMISSIONS (1 GHZ ~ 3 GHZ) .....</i>	<i>29</i>
8.3. <i>SPURIOUS EMISSIONS (3 GHZ ~ 18 GHZ) .....</i>	<i>35</i>
8.4. <i>SPURIOUS EMISSIONS (9 KHZ ~ 30 MHZ).....</i>	<i>47</i>
8.5. <i>SPURIOUS EMISSIONS (30 MHZ ~ 1 GHZ) .....</i>	<i>50</i>
8.6. <i>SPURIOUS EMISSIONS (18 GHZ ~ 26 GHZ) .....</i>	<i>52</i>
<b>9. ANTENNA REQUIREMENTS.....</b>	<b>54</b>



# 1. ATTESTATION OF TEST RESULTS

## Applicant Information

Company Name: Guangzhou Shikun Electronics Co., Ltd  
Address: NO.6 Liankun Road, Huangpu District, Guangzhou, China

## Manufacturer Information

Company Name: Guangzhou Shikun Electronics Co., Ltd  
Address: NO.6 Liankun Road, Huangpu District, Guangzhou, China

## EUT Information

EUT Name: IEEE 802.11a/b/g/n/ac 2T2R USB Wi-Fi Module Integrated  
Bluetooth 2.1+EDR/4.2/5.1  
Model: SKI.WB663U.2  
Sample Received Date: September 2, 2022  
Sample Status: Normal  
Sample ID: 5303796  
Date of Tested: September 5, 2022 ~ September 14, 2022

APPLICABLE STANDARDS	
STANDARD	TEST RESULTS
CFR 47 FCC PART 15 SUBPART C	PASS
ISED RSS-247 Issue 2	PASS
ISED RSS-GEN Issue 5	PASS

Prepared By:

Kebo Zhang  
Senior Project Engineer

Checked By:

Denny Huang  
Senior Project Engineer

Approved By:

Stephen Guo  
Laboratory Manager



## 2. TEST METHODOLOGY

All tests were performed in accordance with the standard CFR 47 FCC PART 15 SUBPART C ISED RSS-247 ISSUE 2, KDB 558074 D01 15.247 Meas Guidance v05r02, 414788 D01 Radiated Test Site v01r01, CFR 47 FCC Part 2, CFR 47 FCC Part 15, ANSI C63.10-2013, ISED RSS-247 Issue 2 and ISED RSS-GEN Issue 5.

## 3. FACILITIES AND ACCREDITATION

Accreditation Certificate	<p><b>A2LA (Certificate No.: 4102.01)</b> UL Verification Services (Guangzhou) Co., Ltd. Song Shan Lake Branch. has been assessed and proved to be in compliance with A2LA.</p> <p><b>FCC (FCC Designation No.: CN1187)</b> UL Verification Services (Guangzhou) Co., Ltd. Song Shan Lake Branch. Has been recognized to perform compliance testing on equipment subject to the Commission's Declaration of Conformity (DoC) and Certification rules</p> <p><b>ISED (Company No.: 21320)</b> UL Verification Services (Guangzhou) Co., Ltd. Song Shan Lake Branch. has been registered and fully described in a report filed with ISED. The Company Number is 21320 and the test lab Conformity Assessment Body Identifier (CABID) is CN0046.</p> <p><b>VCCI (Registration No.: G-20019, R-20004, C-20012 and T-20011)</b> UL Verification Services (Guangzhou) Co., Ltd. Song Shan Lake Branch. has been assessed and proved to be in compliance with VCCI, the Membership No. is 3793. Facility Name: Chamber D, the VCCI registration No. is G-20019 and R-20004 Shielding Room B , the VCCI registration No. is C-20012 and T-20011</p>
---------------------------	---

Note1:

All tests measurement facilities use to collect the measurement data are located at Building 10, Innovation Technology Park, No. 1, Li Bin Road, Song Shan Lake Hi-Tech Development Zone Dongguan, 523808, People's Republic of China.

Note2:

The test anechoic chamber in UL Verification Services (Guangzhou) Co., Ltd. Song Shan Lake Branch had been calibrated and compared to the open field sites and the test anechoic chamber is shown to be equivalent to or worst case from the open field site.

Note3:

For below 30 MHz, lab had performed measurements at test anechoic chamber and comparing to measurements obtained on an open field site. And these measurements below 30 MHz had been correlated to measurements performed on an OFS.



## 4. CALIBRATION AND UNCERTAINTY

### 4.1. MEASURING INSTRUMENT CALIBRATION

The measuring equipment utilized to perform the tests documented in this report has been calibrated in accordance with the manufacturer's recommendations and is traceable to recognized national standards.

### 4.2. MEASUREMENT UNCERTAINTY

Where relevant, the following measurement uncertainty levels have been estimated for tests performed on the apparatus:

Test Item	Uncertainty
Conduction emission	3.62 dB
Radiated Emission (Included Fundamental Emission) (9 kHz ~ 30 MHz)	2.2 dB
Radiated Emission (Included Fundamental Emission) (30 MHz ~ 1 GHz)	4.00 dB
Radiated Emission (Included Fundamental Emission) (1 GHz to 26 GHz)	5.78 dB (1 GHz ~ 18 GHz)
	5.23 dB (18 GHz ~ 26 GHz)
Note: This uncertainty represents an expanded uncertainty expressed at approximately the 95% confidence level using a coverage factor of k=2.	

## 5. EQUIPMENT UNDER TEST

### 5.1. DESCRIPTION OF EUT

EUT Name	IEEE 802.11a/b/g/n/ac 2T2R USB Wi-Fi Module Integrated Bluetooth 2.1+EDR/4.2/5.1	
Model	SKI.WB663U.2	
Technology	Bluetooth - Low Energy	
Transmit Frequency Range	2402 MHz ~ 2480 MHz	
Modulation	GFSK	
Data Rate	LE 1M	1 Mbps
	LE 2M	2 Mbps
Power Supply	DC 3.3 V	

### 5.2. CHANNEL LIST

Channel	Frequency (MHz)	Channel	Frequency (MHz)	Channel	Frequency (MHz)	Channel	Frequency (MHz)
0	2402	11	2424	22	2446	33	2468
1	2404	12	2426	23	2448	34	2470
2	2406	13	2428	24	2450	35	2472
3	2408	14	2430	25	2452	36	2474
4	2410	15	2432	26	2454	37	2476
5	2412	16	2434	27	2456	38	2478
6	2414	17	2436	28	2458	39	2480
7	2416	18	2438	29	2460	/	/
8	2418	19	2440	30	2462	/	/
9	2420	20	2442	31	2464	/	/
10	2422	21	2444	32	2468	/	/

### 5.3. MAXIMUM EIRP

Test Mode	Frequency (MHz)	Channel Number	Maximum Peak Output Power (dBm)	Maximum EIRP (dBm)
LE 1M	2402 ~ 2480	0-39[40]	5.34	7.81
LE 2M	2402 ~ 2480	0-39[40]	5.26	7.73



#### 5.4. TEST CHANNEL CONFIGURATION

Test Mode	Test Channel	Frequency
LE 1M	CH 0(Low Channel), CH 19(MID Channel), CH 39(High Channel)	2402 MHz, 2440 MHz, 2480 MHz
LE 2M	CH 0(Low Channel), CH 19(MID Channel), CH 39(High Channel)	2402 MHz, 2440 MHz, 2480 MHz

#### 5.5. THE WORSE CASE POWER SETTING PARAMETER

The Worse Case Power Setting Parameter under 2400 ~ 2483.5 MHz Band				
Test Software Version		WCN_Combotool		
Modulation Type	Transmit Antenna Number	Test Software setting value		
		CH 0	CH 19	CH 39
LE 1M	1	Default	Default	Default
LE 2M	1	Default	Default	Default

#### 5.6. DESCRIPTION OF AVAILABLE ANTENNAS

Antenna	Frequency (MHz)	Antenna Type	MAX Antenna Gain (dBi)
1	2402-2480	FPC	2.47

Test Mode	Transmit and Receive Mode	Description
LE 1M	<input checked="" type="checkbox"/> 1TX, 1RX	Antenna 1 can be used as transmitting/receiving antenna.
LE 2M	<input checked="" type="checkbox"/> 1TX, 1RX	Antenna 1 can be used as transmitting/receiving antenna.

Note:  
1.BT&WLAN 2.4G, BT & WLAN 5G, WLAN 2.4G & WLAN 5G can't transmit simultaneously.  
(Declared by client)

Note: The value of the antenna gain was declared by customer.

## 5.7. DESCRIPTION OF TEST SETUP

### SUPPORT EQUIPMENT

Item	Equipment	Brand Name	Model Name	Remarks
1	Laptop	Dell	Vostro 3902	/
2	Laptop	ThinkPad	E480	/
3	Test fixture	/	/	/
4	Switching Adapter	FLYPOWER	PS65IBCAY5000H	Input: AC 100-240 V, 50/60 Hz, 1.5A Output: DC 12.0 V, 5000 mA

### I/O CABLES

Cable No	Port	Connector Type	Cable Type	Cable Length(m)	Remarks
1	USB	USB	Unshielded	1.0	/

### ACCESSORIES

Item	Accessory	Brand Name	Model Name	Description
/	/	/	/	/

### TEST SETUP

The EUT can work in engineering mode with a software through a PC.

### SETUP DIAGRAM FOR TESTS

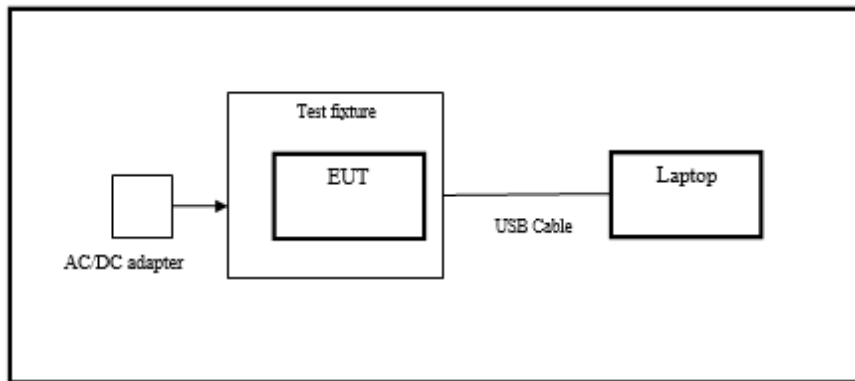

**6. MEASURING EQUIPMENT AND SOFTWARE USED**

Radiated Emissions					
Equipment	Manufacturer	Model No.	Serial No.	Last Cal.	Due Date
MXE EMI Receiver	KESIGHT	N9038A	MY56400036	Oct.30, 2021	Oct.29, 2022
Hybrid Log Periodic Antenna	TDK	HLP-3003C	130959	Aug.02, 2021	Aug.01, 2024
Preamplifier	HP	8447D	2944A09099	Oct.30, 2021	Oct.29, 2022
EMI Measurement Receiver	R&S	ESR26	101377	Oct.30, 2021	Oct.29, 2022
Horn Antenna	TDK	HRN-0118	130940	July 20, 2021	July 19, 2024
Preamplifier	TDK	PA-02-0118	TRS-305-00067	Oct.30, 2021	Oct.29, 2022
Horn Antenna	Schwarzbeck	BBHA9170	697	July 20, 2021	July 19, 2024
Preamplifier	TDK	PA-02-2	TRS-307-00003	Oct.31, 2021	Oct.30, 2022
Preamplifier	TDK	PA-02-3	TRS-308-00002	Oct.31, 2021	Oct.30, 2022
Loop antenna	Schwarzbeck	1519B	00008	Dec.14, 2021	Dec.13, 2024
Preamplifier	TDK	PA-02-001-3000	TRS-302-00050	Oct.31, 2021	Oct.30, 2022
High Pass Filter	Wi	WHKX10-2700-3000-18000-40SS	23	Oct.31, 2021	Oct.30, 2022
Band Reject Filter	Wainwright	WRCJV8-2350-2400-2483.5-2533.5-40SS	4	Oct.31, 2021	Oct.30, 2022
Software					
Description		Manufacturer	Name	Version	
Test Software for Radiated Emissions		Farad	EZ-EMC	Ver. UL-3A1	

Other Instrument					
Equipment	Manufacturer	Model No.	Serial No.	Last Cal.	Due Date
Dual Channel Power Meter	Keysight	N1912A	MY55416024	Oct.30, 2021	Oct.29, 2022
Power Sensor	Keysight	USB Wideband Power Sensor	MY5100022	Oct.30, 2021	Oct.29, 2022

## 7. ANTENNA PORT TEST RESULTS

### 7.1. ON TIME AND DUTY CYCLE

#### LIMITS

None; for reporting purposes only.

#### PROCEDURE

Refer to ANSI C63.10-2013 clause 11.6 Zero – Span Spectrum Analyzer method.

#### TEST SETUP

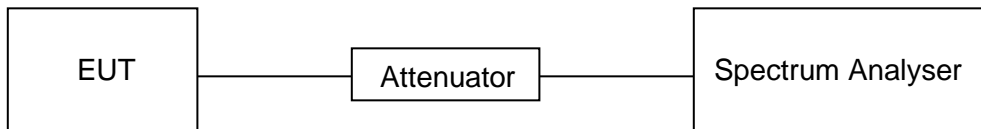

#### TEST RESULTS

Mode	On Time (msec)	Period (msec)	Duty Cycle x (Linear)	Duty Cycle (%)	Duty Cycle Correction Factor (dB)	1/T Minimum VBW (kHz)	Final setting For VBW (kHz)
LE 1M	2.12	2.50	0.8480	84.80	0.72	0.47	0.5
LE 2M	1.07	1.88	0.5691	56.91	2.45	0.93	1

Note:

Duty Cycle Correction Factor=10log (1/x).

Where: x is Duty Cycle (Linear)

Where: T is On Time

If that calculated VBW is not available on the analyzer then the next higher value should be used.

Note: All the test result comes from the original test report.



**TEST GRAPHS**

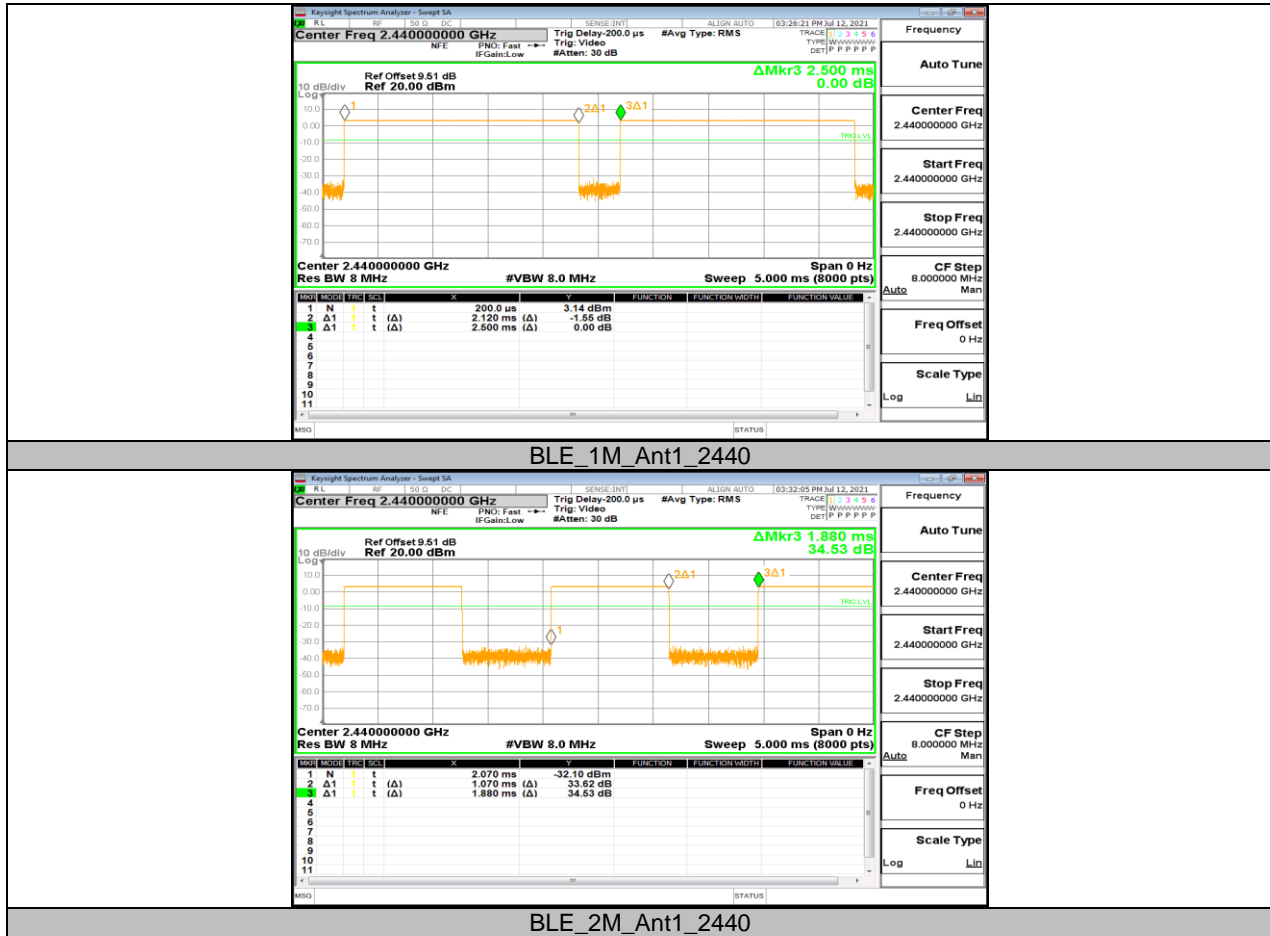

Note: All the test result comes from the original test report.

## 7.2. PEAK CONDUCTED OUTPUT POWER

### LIMITS

CFR 47 FCC Part15 (15.247) Subpart C ISED RSS-247 ISSUE 2			
Section	Test Item	Limit	Frequency Range (MHz)
CFR 47 FCC 15.247(b)(3) ISED RSS-247 5.4 (d)	Peak Conducted Output Power	1 watt or 30 dBm	2400-2483.5

### TEST PROCEDURE

Connect the EUT to a low loss RF cable from the antenna port to the power sensor (video bandwidth is greater than the occupied bandwidth).  
Measure peak emission level, the indicated level is the peak output power, after any corrections for external attenuators and cables.

### TEST SETUP

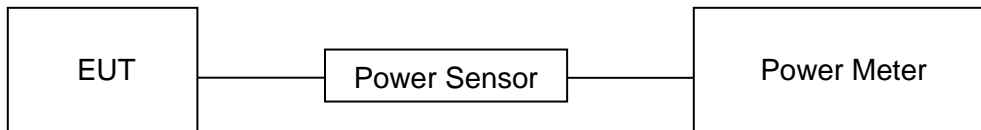

### TEST ENVIRONMENT

Temperature	24.6 °C	Relative Humidity	57.2 %
Atmosphere Pressure	101 kPa	Test Voltage	DC 3.3 V

### RESULTS

Test Mode	Antenna	Channel	Result[dBm]	Limit[dBm]	Verdict
LE 1M	Ant1	2402	5.14	<=30	PASS
		2440	3.26	<=30	PASS
		2480	1.88	<=30	PASS
LE 2M	Ant1	2402	5.03	<=30	PASS
		2440	3.20	<=30	PASS
		2480	1.82	<=30	PASS

Note: All the test result comes from the original test report.



**SPOT CHECK TEST RESULTS**

Test Mode	Antenna	Frequency (MHz)	Result[dBm]	Original Report Test Result [dBm]	Deviation [dB]
LE 1M	Ant1	2402	5.34	5.14	0.20
LE 2M	Ant1	2402	5.26	5.03	0.23



## 8. RADIATED TEST RESULTS

### LIMITS

Please refer to CFR 47 FCC §15.205 and §15.209.

Please refer to ISED RSS-GEN Clause 8.9 and Clause 8.10.

Radiation Disturbance Test Limit for FCC (Class B) (9 kHz ~ 1 GHz)

Emissions radiated outside of the specified frequency bands above 30 MHz			
Frequency Range (MHz)	Field Strength Limit (uV/m) at 3 m	Field Strength Limit (dBuV/m) at 3 m	
		Quasi-Peak	
30 - 88	100	40	
88 - 216	150	43.5	
216 - 960	200	46	
Above 960	500	54	
Above 1000	500	Peak	Average
		74	54

FCC Emissions radiated outside of the specified frequency bands below 30 MHz		
Frequency (MHz)	Field strength (microvolts/meter)	Measurement distance (meters)
0.009-0.490	2400/F(kHz)	300
0.490-1.705	24000/F(kHz)	30
1.705-30.0	30	30

ISED General field strength limits at frequencies below 30 MHz

Table 6 – General field strength limits at frequencies below 30 MHz		
Frequency	Magnetic field strength (H-Field) (µA/m)	Measurement distance (m)
9 - 490 kHz <sup>Note 1</sup>	6.37/F (F in kHz)	300
490 - 1705 kHz	63.7/F (F in kHz)	30
1.705 - 30 MHz	0.08	30

**Note 1:** The emission limits for the ranges 9-90 kHz and 110-490 kHz are based on measurements employing a linear average detector.





ISED Restricted bands please refer to ISED RSS-GEN Clause 8.10

Table 7 – Restricted frequency bands <sup>Note 1</sup>		
MHz	MHz	GHz
0.090 - 0.110	149.9 - 150.05	9.0 - 9.2
0.495 - 0.505	156.52475 - 156.52525	9.3 - 9.5
2.1735 - 2.1905	156.7 - 156.9	10.6 - 12.7
3.020 - 3.026	162.0125 - 167.17	13.25 - 13.4
4.125 - 4.128	167.72 - 173.2	14.47 - 14.5
4.17725 - 4.17775	240 - 285	15.35 - 16.2
4.20725 - 4.20775	322 - 335.4	17.7 - 21.4
5.677 - 5.683	399.9 - 410	22.01 - 23.12
6.215 - 6.218	608 - 614	23.6 - 24.0
6.26775 - 6.26825	960 - 1427	31.2 - 31.8
6.31175 - 6.31225	1435 - 1626.5	36.43 - 36.5
8.291 - 8.294	1645.5 - 1646.5	Above 38.6
8.362 - 8.366	1660 - 1710	
8.37625 - 8.38675	1718.8 - 1722.2	
8.41425 - 8.41475	2200 - 2300	
12.29 - 12.293	2310 - 2390	
12.51975 - 12.52025	2483.5 - 2500	
12.57675 - 12.57725	2655 - 2900	
13.36 - 13.41	3260 - 3267	
16.42 - 16.423	3332 - 3339	
16.69475 - 16.69525	3345.8 - 3358	
16.80425 - 16.80475	3500 - 4400	
25.5 - 25.67	4500 - 5150	
37.5 - 38.25	5350 - 5460	
73 - 74.6	7250 - 7750	
74.8 - 75.2	8025 - 8500	
108 - 138		

**Note 1:** Certain frequency bands listed in table 7 and in bands above 38.6 GHz are designated for licence-exempt applications. These frequency bands and the requirements that apply to related devices are set out in the 200 and 300 series of RSSs.

FCC Restricted bands of operation refer to FCC §15.205 (a):

MHz	MHz	MHz	GHz
0.090-0.110	16.42-16.423	399.9-410	4.5-5.15
<sup>1</sup> 0.495-0.505	16.69475-16.69525	608-614	5.35-5.46
2.1735-2.1905	16.80425-16.80475	960-1240	7.25-7.75
4.125-4.128	25.5-25.67	1300-1427	8.025-8.5
4.17725-4.17775	37.5-38.25	1435-1626.5	9.0-9.2
4.20725-4.20775	73-74.6	1645.5-1646.5	9.3-9.5
6.215-6.218	74.8-75.2	1660-1710	10.6-12.7
6.26775-6.26825	108-121.94	1718.8-1722.2	13.25-13.4
6.31175-6.31225	123-138	2200-2300	14.47-14.5
8.291-8.294	149.9-150.05	2310-2390	15.35-16.2
8.362-8.366	156.52475-156.52525	2483.5-2500	17.7-21.4
8.37625-8.38675	156.7-156.9	2690-2900	22.01-23.12
8.41425-8.41475	162.0125-167.17	3260-3267	23.6-24.0
12.29-12.293	167.72-173.2	3332-3339	31.2-31.8
12.51975-12.52025	240-285	3345.8-3358	36.43-36.5
12.57675-12.57725	322-335.4	3600-4400	( <sup>2</sup> )
13.36-13.41			

Note: <sup>1</sup>Until February 1, 1999, this restricted band shall be 0.490-0.510 MHz.

<sup>2</sup>Above 38.6c

**TEST PROCEDURE**

Below 30 MHz

The setting of the spectrum analyser

RBW	200 Hz (From 9 kHz to 0.15 MHz)/ 9 kHz (From 0.15 MHz to 30 MHz)
VBW	200 Hz (From 9 kHz to 0.15 MHz)/ 9 kHz (From 0.15 MHz to 30 MHz)
Sweep	Auto

1. The testing follows the guidelines in ANSI C63.10-2013 clause 6.4.
2. The EUT was arranged to its worst case and then turntable (from 0 degree to 360 degrees) to find the maximum reading. A pre-amp and a high pass filter are used for the test in order to get better signal level. Both Horizontal, Face-on and Face-off polarizations of the antenna are set to make the measurement.
3. The EUT was placed on a turntable with 80 cm above ground.
4. The EUT was set 3 meters from the interference receiving antenna, which was mounted on the top of a 1 m height antenna tower.
5. The radiated emission limits are based on measurements employing a CISPR quasi-peak detector except for the frequency bands 9-90 kHz, 110-490 kHz and above 1000 MHz Radiated emission limits in these three bands are based on measurements employing an average detector.
6. For measurement below 1 GHz, the initial step in collecting conducted emission data is a spectrum analyzer peak detector mode pre-scanning the measurement frequency range. Significant peaks are then marked and then Quasi Peak and average detector mode re-measured. If the emission level of the EUT measured by the peak detector is 3 dB lower than the applicable limit, the peak emission level will be reported. Otherwise, the emission measurement will be repeated using the quasi-peak and average detector and reported.
7. Although these tests were performed other than open field site, adequate comparison measurements were confirmed against 30m open field site. Therefore sufficient tests were made to demonstrate that the alternative site produces results that correlate with the ones of tests made in an open field site based on KDB 414788.
8. The limits in CFR 47, Part 15, Subpart C, paragraph 15.209 (a), are identical to those in RSS-GEN Section 8.9, Table 6, since the measurements are performed in terms of magnetic field strength and converted to electric field strength levels (as reported in the table) using the free space impedance of  $377\Omega$ . For example, the measurement frequency X KHz resulted in a level of Y dBuV/m, which is equivalent to  $Y-51.5 = Z$  dBuA/m, which has the same margin, W dB, to the corresponding RSS-GEN Table 6 limit as it has to be 15.209(a) limit.



Below 1 GHz and above 30 MHz

The setting of the spectrum analyser

RBW	120 kHz
VBW	300 kHz
Sweep	Auto
Detector	Peak/QP
Trace	Max hold

1. The testing follows the guidelines in ANSI C63.10-2013 clause 6.5.
2. The EUT was arranged to its worst case and then tune the antenna tower (from 1 m to 4 m) and turntable (from 0 degree to 360 degrees) to find the maximum reading. A pre-amp and a high pass filter are used for the test in order to get better signal level. Both horizontal and vertical polarizations of the antenna are set to make the measurement.
3. The EUT was placed on a turntable with 80 cm above ground.
4. The EUT was set 3 meters from the interference receiving antenna, which was mounted on the top of a variable height antenna tower.
5. For measurement below 1 GHz, the initial step in collecting conducted emission data is a spectrum analyzer peak detector mode pre-scanning the measurement frequency range. Significant peaks are then marked and then Quasi Peak detector mode re-measured. If the emission level of the EUT measured by the peak detector is 3 dB lower than the applicable limit, the peak emission level will be reported. Otherwise, the emission measurement will be repeated using the quasi-peak detector and reported.



Above 1 GHz

The setting of the spectrum analyser

RBW	1 MHz
VBW	PEAK: 3 MHz AVG: see note 6
Sweep	Auto
Detector	Peak
Trace	Max hold

1. The testing follows the guidelines in ANSI C63.10-2013 clause 6.6.
2. The EUT was arranged to its worst case and then tune the antenna tower (from 1 m to 4 m) and turntable (from 0 degree to 360 degrees) to find the maximum reading. A pre-amp and a high pass filter are used for the test in order to get better signal level. Both horizontal and vertical polarizations of the antenna are set to make the measurement.
3. The EUT was placed on a turntable with 1.5 m above ground.
4. The EUT was set 3 meters from the interference receiving antenna, which was mounted on the top of a variable height antenna tower.
5. For measurement above 1 GHz, the emission measurement will be measured by the peak detector. This peak level, once corrected, must comply with the limit specified in Section 15.209.
6. For measurements above 1 GHz the resolution bandwidth is set to 1 MHz, then the video bandwidth is set to 3 MHz for peak measurements and 1 MHz resolution bandwidth with 1/T video bandwidth with peak detector for average measurements. For the Duty Cycle please refer to clause 7.5.ON TIME AND DUTY CYCLE.

X axis, Y axis, Z axis positions:

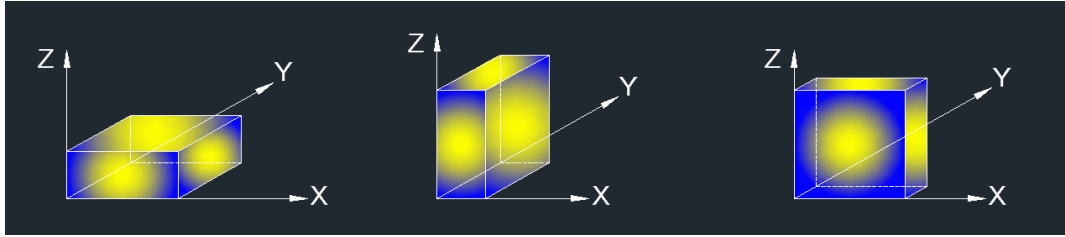

Note: For all radiated test, EUT in each of three orthogonal axis emissions had been tested, but only the worst case (X axis) data recorded in the report.

For Restricted Bandedge:

Note:

1. Measurement = Reading Level + Correct Factor.
2. If Peak Result complies with AV limit, AV Result is deemed to comply with AV limit.
3. Peak: Peak detector.
4. AVG:  $VBW=1/Ton$ , where: Ton is the transmitting duration.
5. For the transmitting duration, please refer to clause 7.1.
6. Only the worst data was recorded, if it complies with the limit, the other emissions deemed to comply with the limit.
7. Both horizontal and vertical have been tested, only the worst data was recorded in the report.
8. All modes, channels and antennas have been tested, only the worst data was recorded in the report.

For Radiate Spurious emission (9 kHz ~ 30 MHz):

Note:

1. Measurement = Reading Level + Correct Factor.
2. If Peak Result complies with AV and QP limit, AV and QP Result are deemed to comply with AV limit.
3. All 3 polarizations (Horizontal, Face-on and Face-off) of the loop antenna had been tested, but only the worst data recorded in the report.
4. All modes, channels and antennas have been tested, only the worst data was recorded in the report.

For Radiate Spurious Emission (30 MHz ~ 1 GHz):

Note:

1. Result Level = Read Level + Correct Factor.
2. If Peak Result complies with QP limit, QP Result is deemed to comply with QP limit.
3. All modes, channels and antennas have been tested, only the worst data was recorded in the report.

For Radiate Spurious Emission (1 GHz ~ 3 GHz):

1. Measurement = Reading Level + Correct Factor.
2. If Peak Result complies with AV limit, AV Result is deemed to comply with AV limit.
3. Peak: Peak detector.
4. AVG:  $VBW=1/Ton$ , where: Ton is the transmitting duration.
5. For the transmitting duration, please refer to clause 7.1.
6. Filter losses were only considered in the spurious frequency bands and the authorized band was not corrected for Band reject filter losses.
7. Proper operation of the transmitter prior to adding the filter to the measurement chain.
8. All modes, channels and antennas have been tested, only the worst data was recorded in the report.

For Radiate Spurious Emission (3 GHz ~ 18 GHz):

Note:

1. Peak Result = Reading Level + Correct Factor.
2. If Peak Result complies with AV limit, AV Result is deemed to comply with AV limit.
3. Peak: Peak detector.
4. AVG:  $VBW=1/Ton$ , where: Ton is the transmitting duration.
5. For the transmitting duration, please refer to clause 7.1.
6. Filter losses were only considered in the spurious frequency bands and the authorized band was not corrected for High Pass Filter losses.
7. Proper operation of the transmitter prior to adding the filter to the measurement chain.
8. All modes, channels and antennas have been tested, only the worst data was recorded in the report.

For Radiate Spurious emission (18 GHz ~ 26 GHz):

Note:

1. Measurement = Reading Level + Correct Factor.
2. If Peak Result complies with AV limit, AV Result is deemed to comply with AV limit.
3. Peak: Peak detector.
4. All modes, channels and antennas have been tested, only the worst data was recorded in the report.

**TEST SETUP**

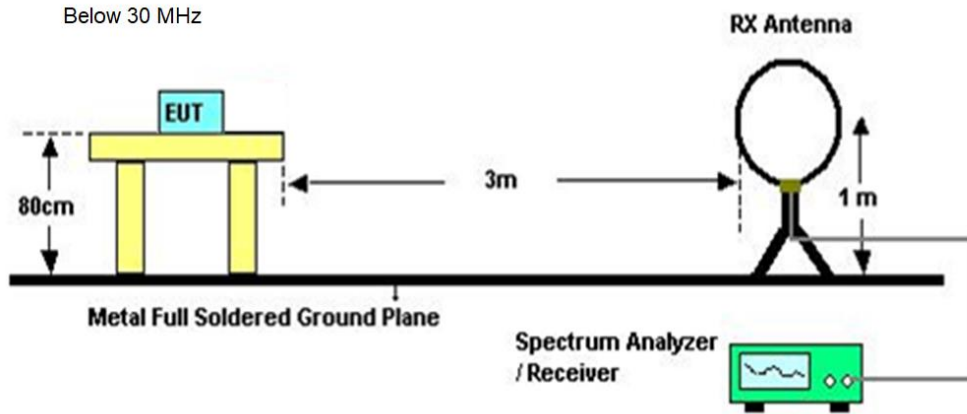

Below 1 GHz and above 30 MHz

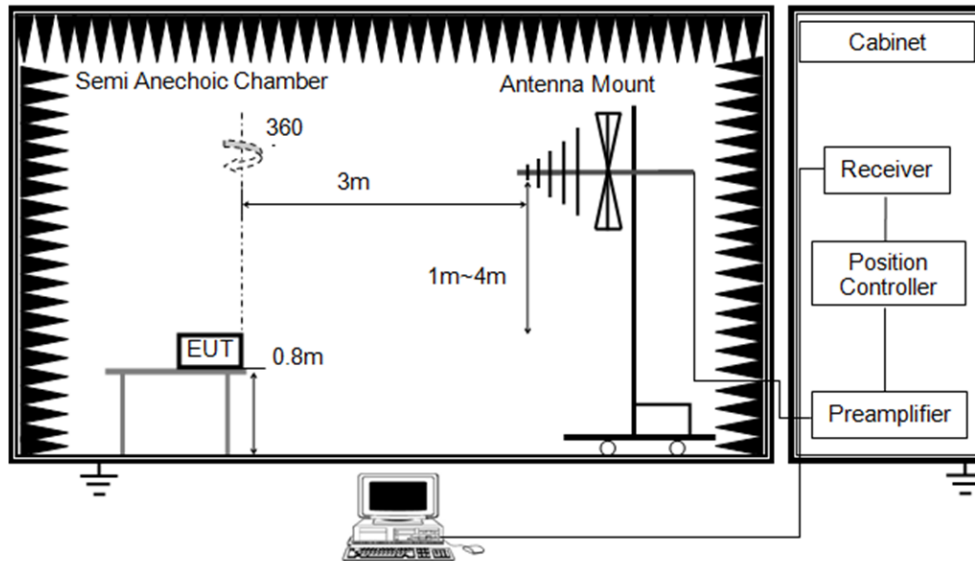

Above 1 GHz

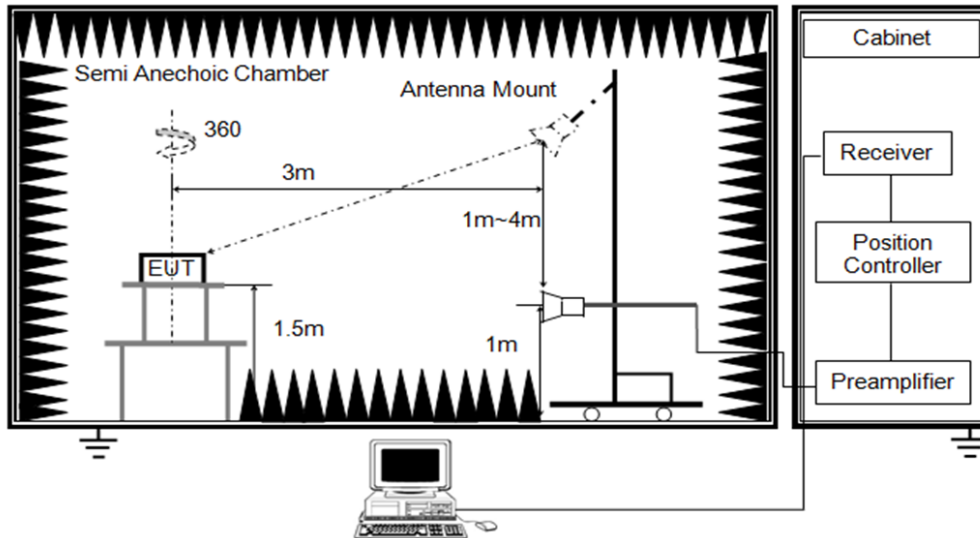



**TEST ENVIRONMENT**

Temperature	25.3 °C	Relative Humidity	65%
Atmosphere Pressure	101 kPa	Test Voltage	DC 3.3 V

**TEST RESULTS**





### 8.1. RESTRICTED BANDEDGE

Test Mode:	LE 1M Peak	Channel:	2402 MHz
Polarity:	Horizontal	Test Voltage:	DC 3.3 V

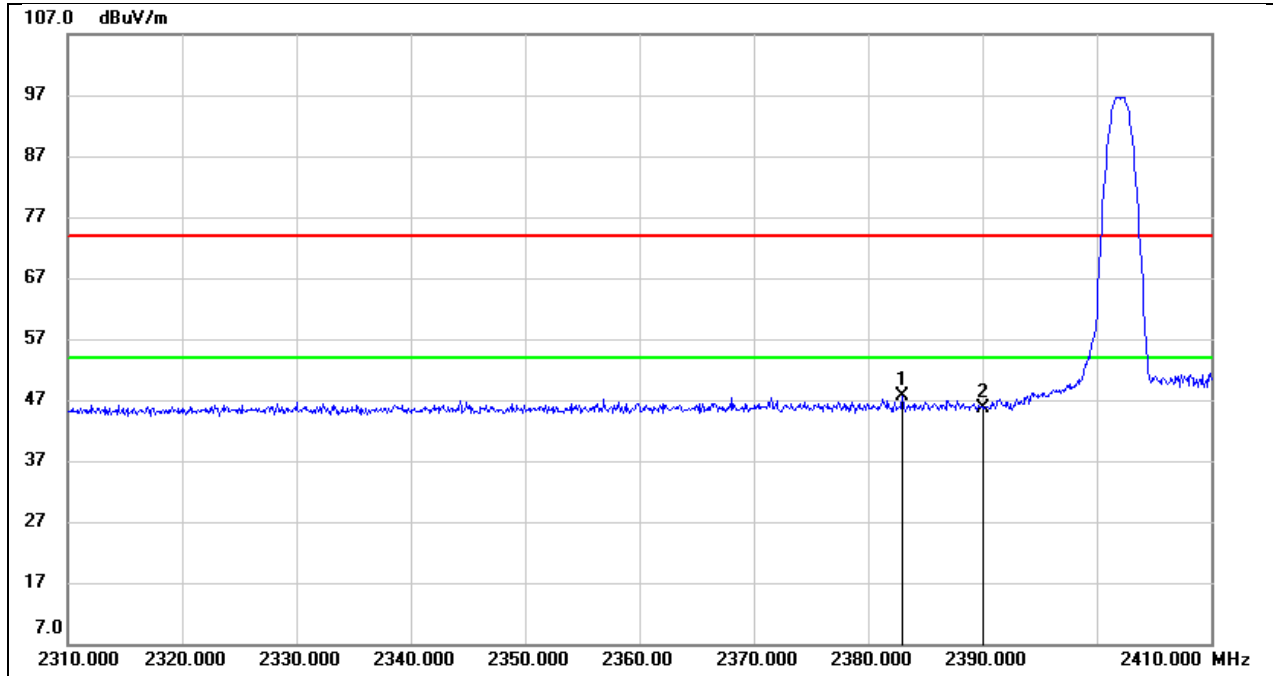

No.	Frequency (MHz)	Reading (dBuV)	Correct (dB/m)	Result (dBuV/m)	Limit (dBuV/m)	Margin (dB)	Remark
1	2383.000	15.40	32.14	47.54	74.00	-26.46	peak
2	2390.000	13.51	32.16	45.67	74.00	-28.33	peak



Test Mode:	LE 1M Peak	Channel:	2480 MHz
Polarity:	Horizontal	Test Voltage:	DC 3.3 V

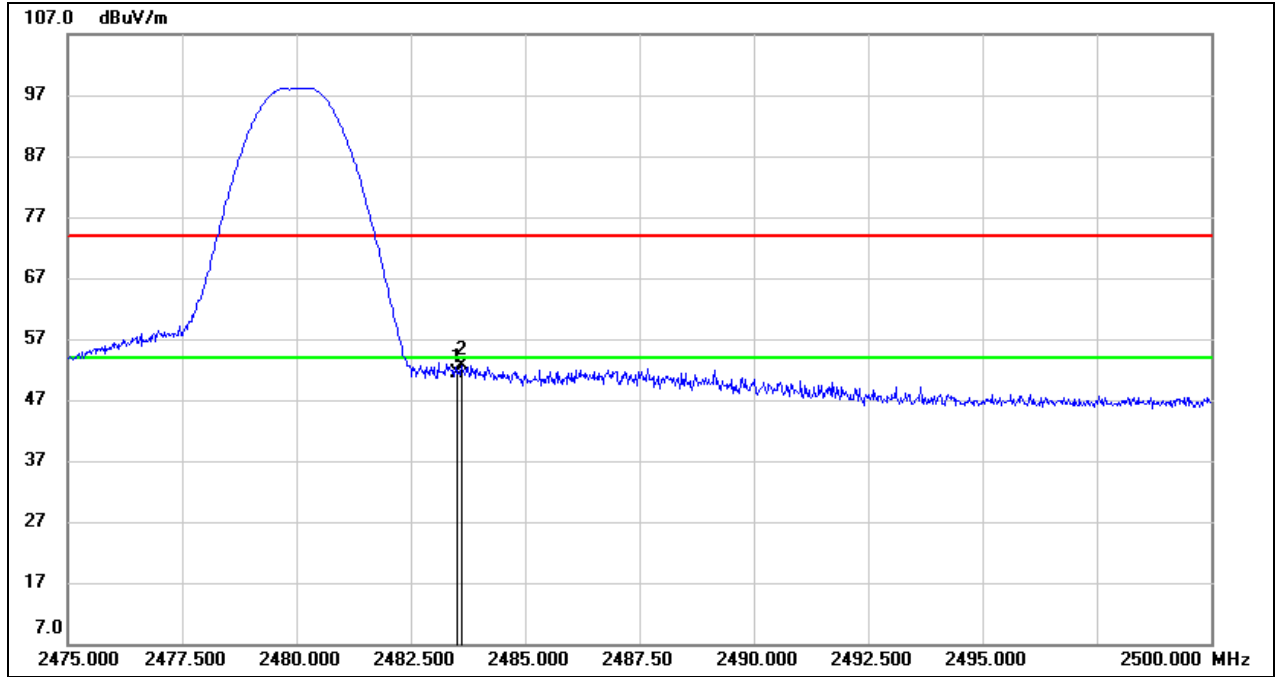

No.	Frequency (MHz)	Reading (dBuV)	Correct (dB/m)	Result (dBuV/m)	Limit (dBuV/m)	Margin (dB)	Remark
1	2483.500	19.02	32.44	51.46	74.00	-22.54	peak
2	2483.600	20.25	32.44	52.69	74.00	-21.31	peak



Test Mode:	LE 2M Peak	Channel:	2402 MHz
Polarity:	Horizontal	Test Voltage:	DC 3.3 V

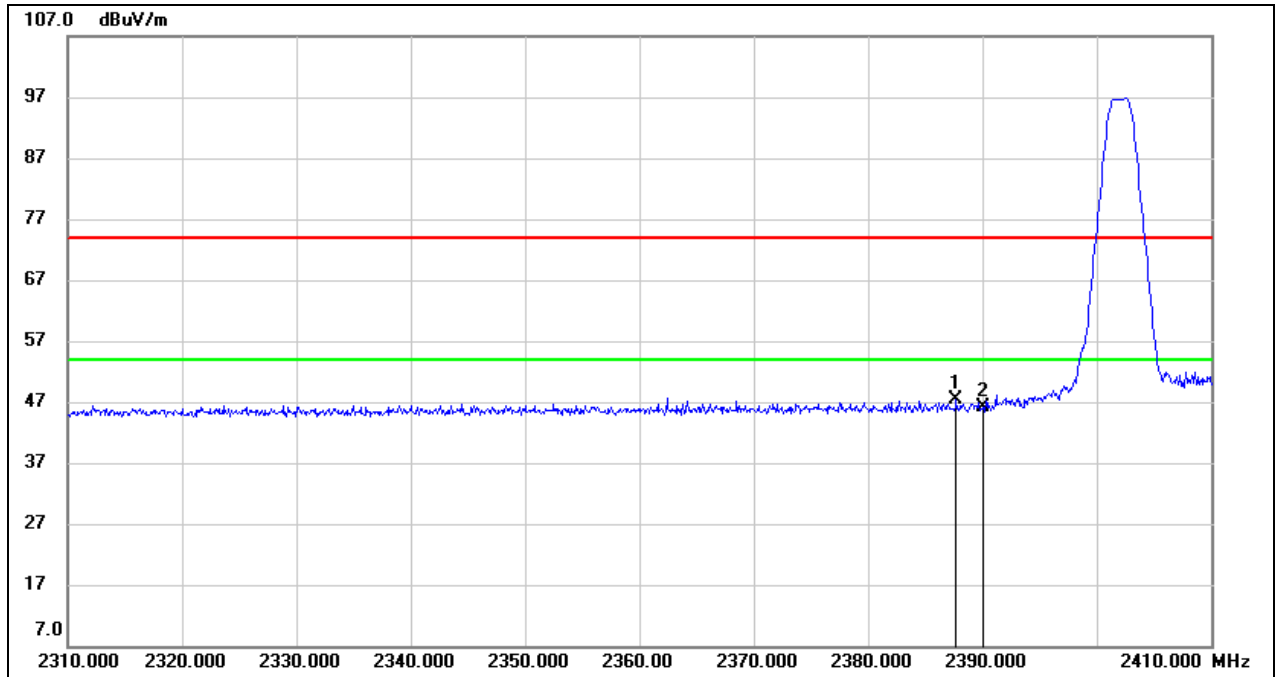

No.	Frequency (MHz)	Reading (dBuV)	Correct (dB/m)	Result (dBuV/m)	Limit (dBuV/m)	Margin (dB)	Remark
1	2387.700	15.34	32.16	47.50	74.00	-26.50	peak
2	2390.000	13.96	32.16	46.12	74.00	-27.88	peak



Test Mode:	LE 2M Peak	Channel:	2480 MHz
Polarity:	Horizontal	Test Voltage:	DC 3.3 V

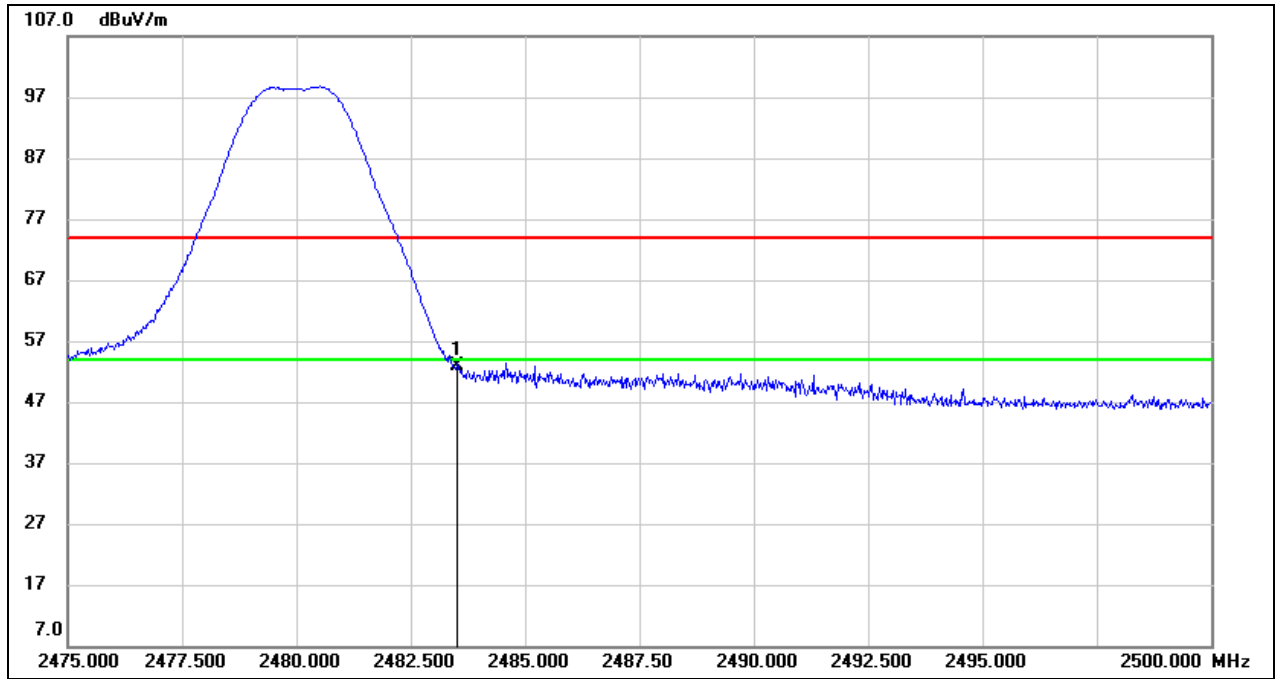

No.	Frequency (MHz)	Reading (dBuV)	Correct (dB/m)	Result (dBuV/m)	Limit (dBuV/m)	Margin (dB)	Remark
1	2483.500	20.50	32.44	52.94	74.00	-21.06	peak



### 8.2. SPURIOUS EMISSIONS (1 GHZ ~ 3 GHZ)

Test Mode:	LE 1M	Channel:	2402 MHz
Polarity:	Horizontal	Test Voltage:	DC 3.3 V

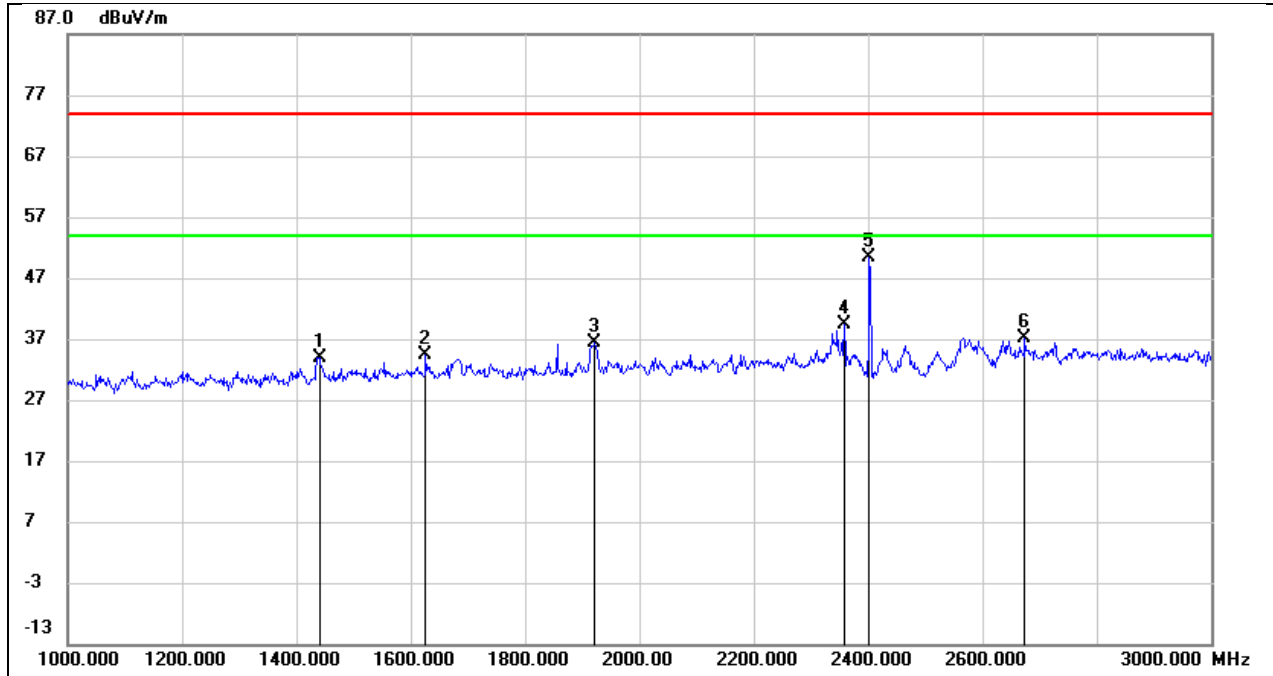

No.	Frequency (MHz)	Reading (dBuV)	Correct (dB/m)	Result (dBuV/m)	Limit (dBuV/m)	Margin (dB)	Remark
1	1440.000	46.87	-12.98	33.89	74.00	-40.11	peak
2	1626.000	46.68	-12.30	34.38	74.00	-39.62	peak
3	1922.000	47.78	-11.32	36.46	74.00	-37.54	peak
4	2358.000	48.54	-9.22	39.32	74.00	-34.68	peak
5	2402.000	59.32	-8.99	50.33	/	/	Fundamental
6	2674.000	45.01	-7.97	37.04	74.00	-36.96	peak



Test Mode:	LE 1M	Channel:	2402 MHz
Polarity:	Vertical	Test Voltage:	DC 3.3 V

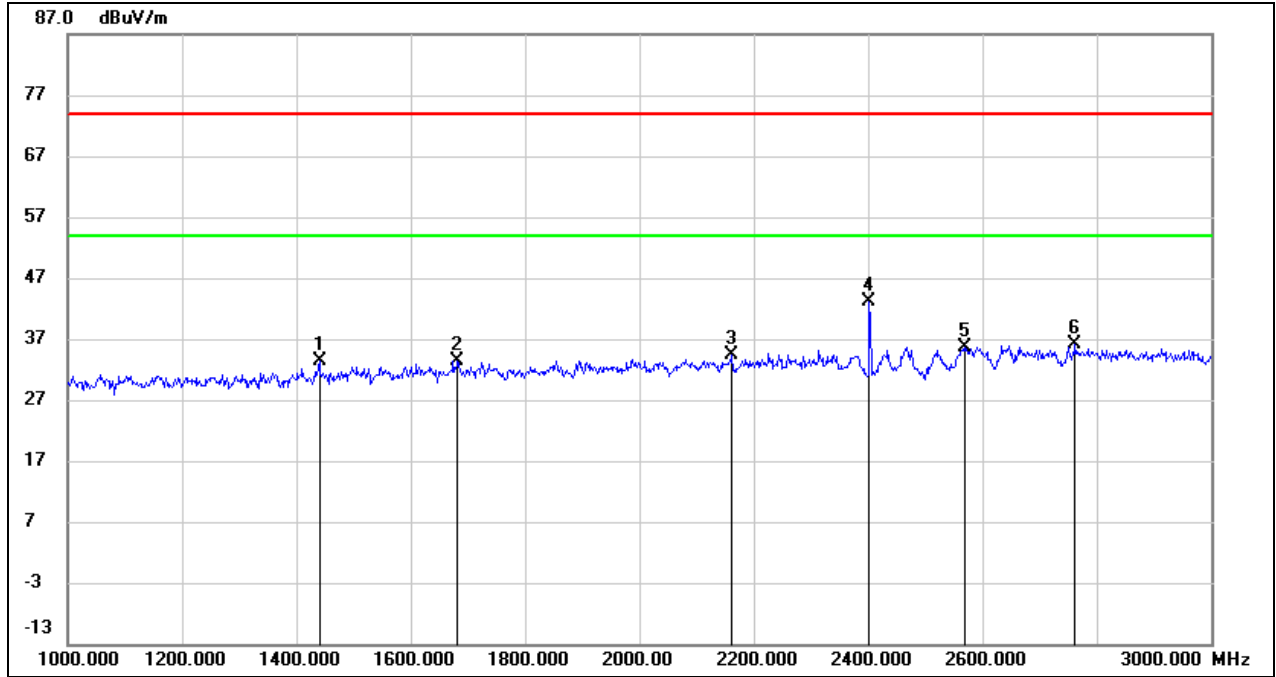

No.	Frequency (MHz)	Reading (dBuV)	Correct (dB/m)	Result (dBuV/m)	Limit (dBuV/m)	Margin (dB)	Remark
1	1440.000	46.32	-12.98	33.34	74.00	-40.66	peak
2	1682.000	45.49	-12.11	33.38	74.00	-40.62	peak
3	2162.000	44.51	-10.23	34.28	74.00	-39.72	peak
4	2402.000	52.04	-8.99	43.05	/	/	Fundamental
5	2568.000	43.86	-8.28	35.58	74.00	-38.42	peak
6	2762.000	43.72	-7.70	36.02	74.00	-37.98	peak



Test Mode:	LE 1M	Channel:	2440 MHz
Polarity:	Horizontal	Test Voltage:	DC 3.3 V

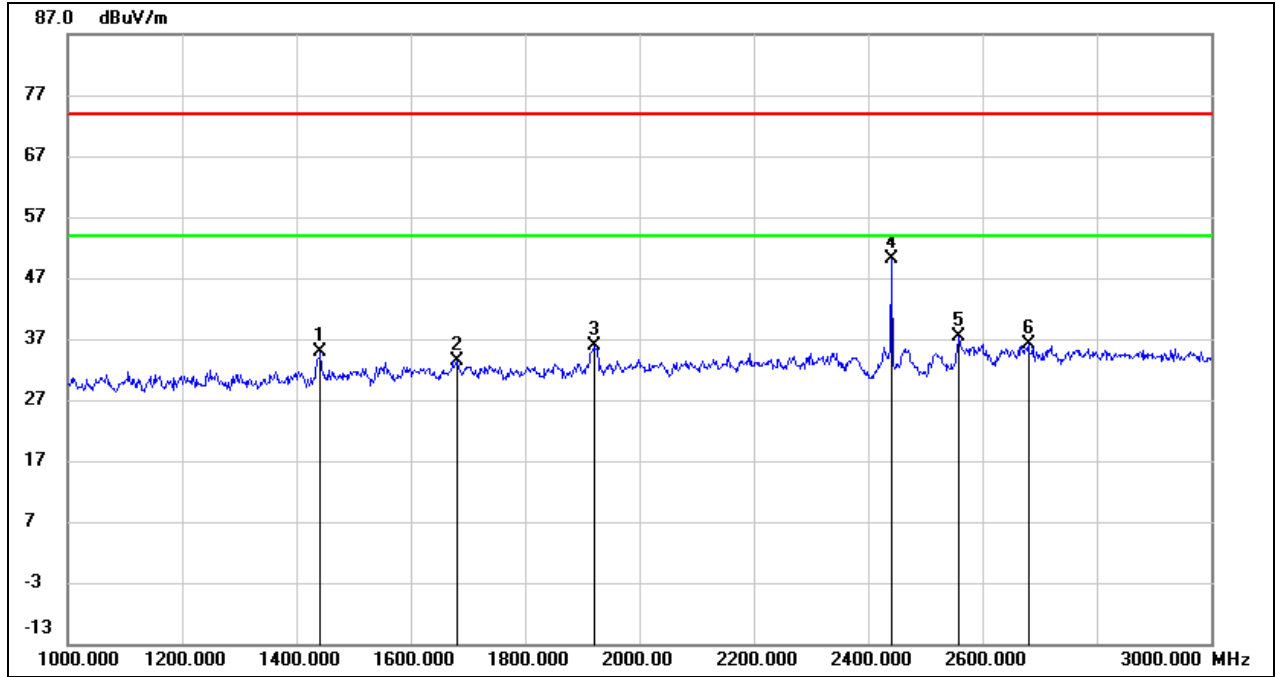

No.	Frequency (MHz)	Reading (dBuV)	Correct (dB/m)	Result (dBuV/m)	Limit (dBuV/m)	Margin (dB)	Remark
1	1442.000	47.83	-12.98	34.85	74.00	-39.15	peak
2	1680.000	45.61	-12.12	33.49	74.00	-40.51	peak
3	1920.000	47.29	-11.32	35.97	74.00	-38.03	peak
4	2440.000	58.92	-8.80	50.12	/	/	Fundamental
5	2558.000	45.68	-8.32	37.36	74.00	-36.64	peak
6	2680.000	43.96	-7.95	36.01	74.00	-37.99	peak



Test Mode:	LE 1M	Channel:	2440 MHz
Polarity:	Vertical	Test Voltage:	DC 3.3 V

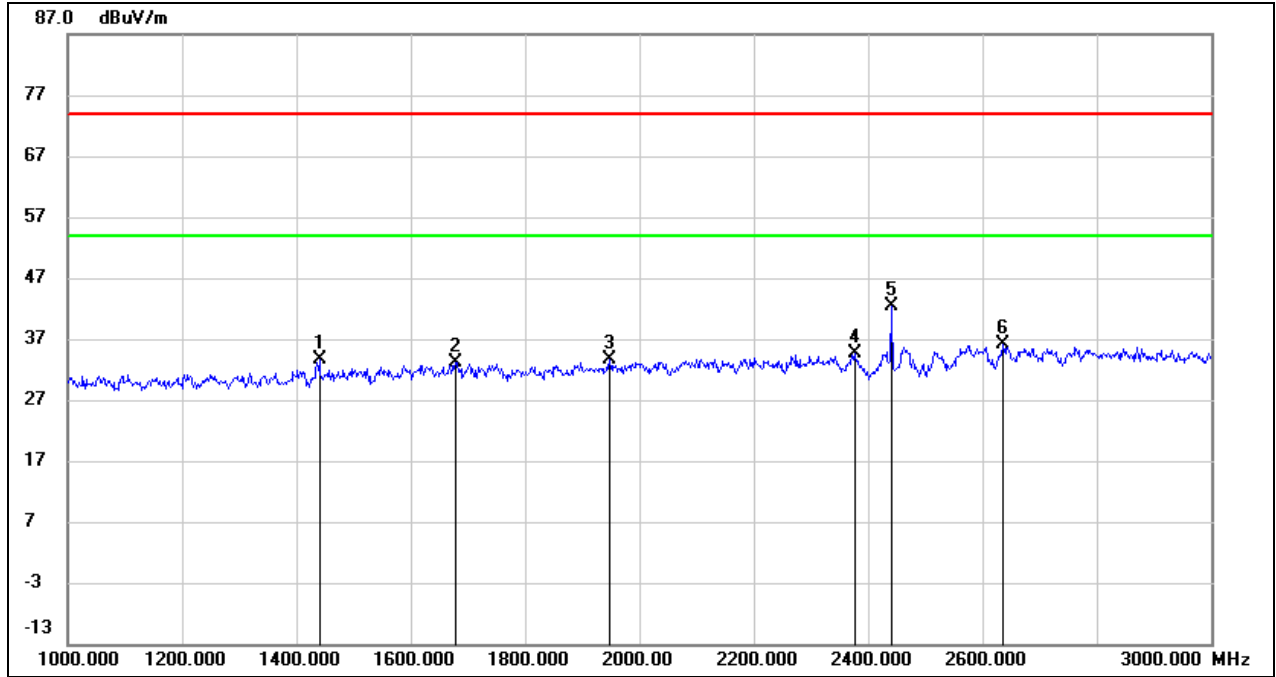

No.	Frequency (MHz)	Reading (dBuV)	Correct (dB/m)	Result (dBuV/m)	Limit (dBuV/m)	Margin (dB)	Remark
1	1440.000	46.65	-12.98	33.67	74.00	-40.33	peak
2	1678.000	45.20	-12.12	33.08	74.00	-40.92	peak
3	1948.000	44.91	-11.23	33.68	74.00	-40.32	peak
4	2376.000	43.76	-9.13	34.63	74.00	-39.37	peak
5	2440.000	51.25	-8.80	42.45	/	/	Fundamental
6	2636.000	44.10	-8.08	36.02	74.00	-37.98	peak





Test Mode:	LE 1M	Channel:	2480 MHz
Polarity:	Horizontal	Test Voltage:	DC 3.3 V

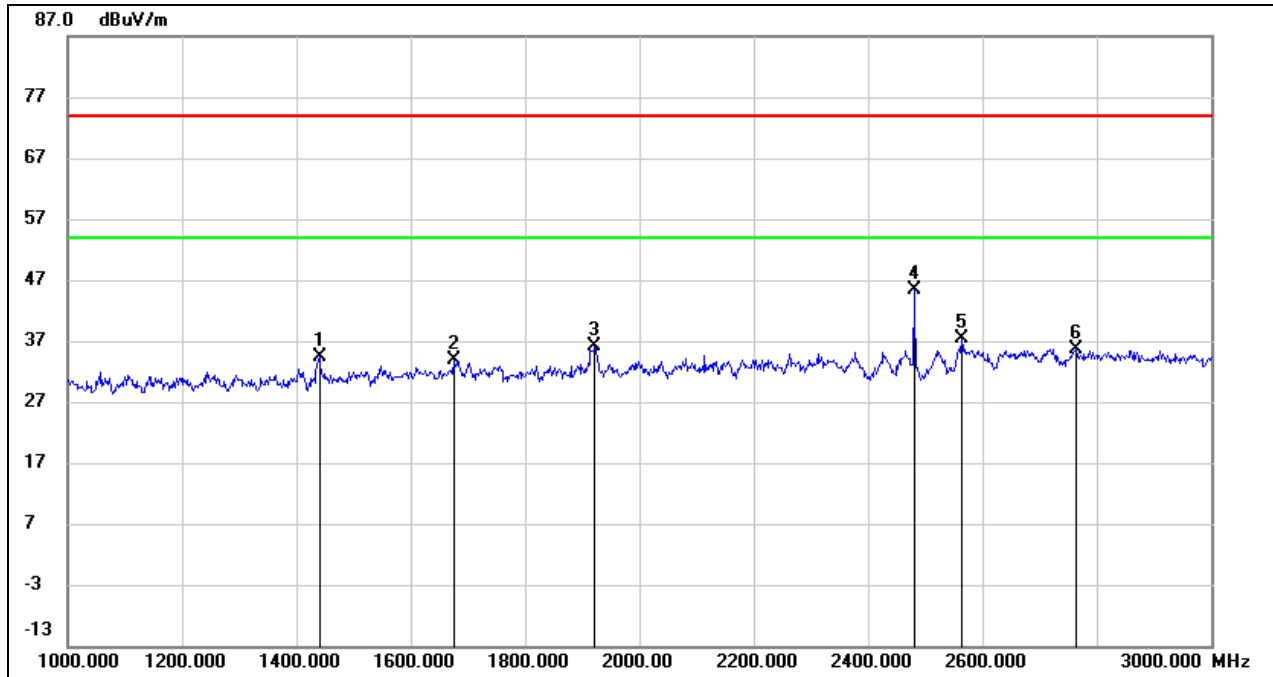

No.	Frequency (MHz)	Reading (dBuV)	Correct (dB/m)	Result (dBuV/m)	Limit (dBuV/m)	Margin (dB)	Remark
1	1440.000	47.40	-12.98	34.42	74.00	-39.58	peak
2	1676.000	45.96	-12.13	33.83	74.00	-40.17	peak
3	1922.000	47.34	-11.32	36.02	74.00	-37.98	peak
4	2480.000	53.89	-8.59	45.30	/	/	Fundamental
5	2564.000	45.59	-8.30	37.29	74.00	-36.71	peak
6	2764.000	43.41	-7.69	35.72	74.00	-38.28	peak



Test Mode:	LE 1M	Channel:	2480 MHz
Polarity:	Vertical	Test Voltage:	DC 3.3 V

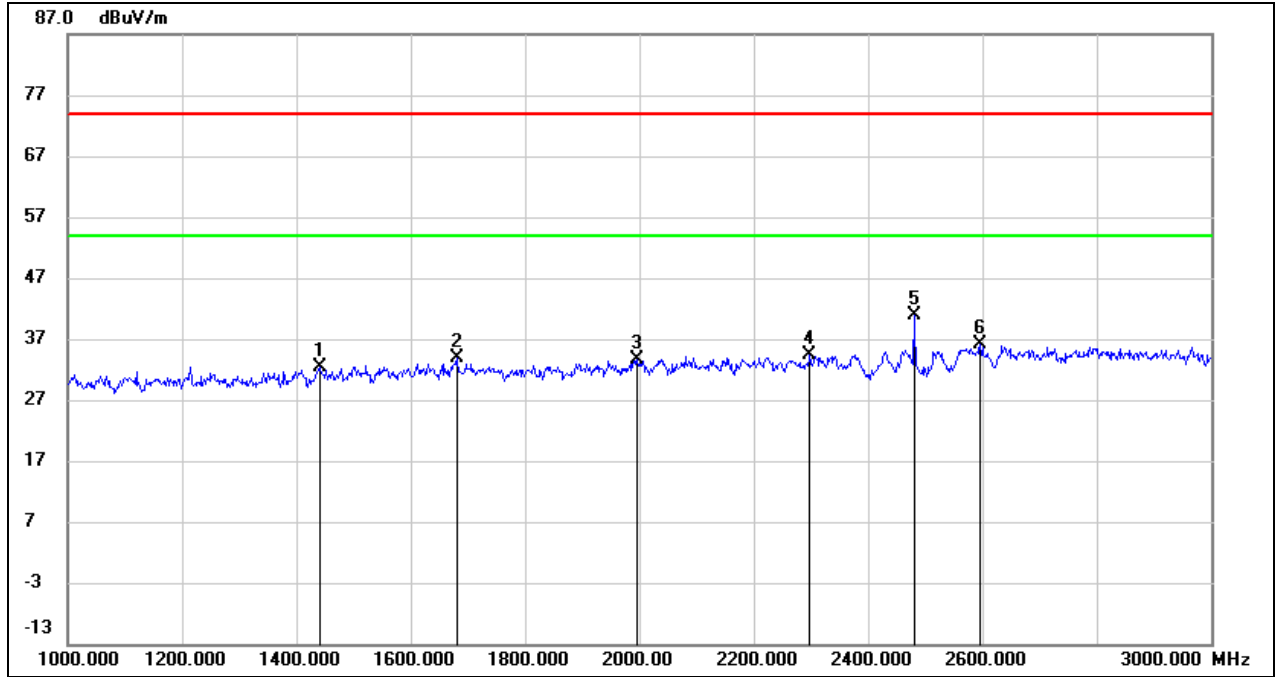

No.	Frequency (MHz)	Reading (dBuV)	Correct (dB/m)	Result (dBuV/m)	Limit (dBuV/m)	Margin (dB)	Remark
1	1440.000	45.42	-12.98	32.44	74.00	-41.56	peak
2	1680.000	45.96	-12.12	33.84	74.00	-40.16	peak
3	1996.000	44.77	-11.07	33.70	74.00	-40.30	peak
4	2298.000	43.92	-9.53	34.39	74.00	-39.61	peak
5	2480.000	49.35	-8.59	40.76	/	/	Fundamental
6	2596.000	44.21	-8.20	36.01	74.00	-37.99	peak



### 8.3. SPURIOUS EMISSIONS (3 GHZ ~ 18 GHZ)

Test Mode:	LE 1M	Channel:	2402 MHz
Polarity:	Horizontal	Test Voltage:	DC 3.3 V

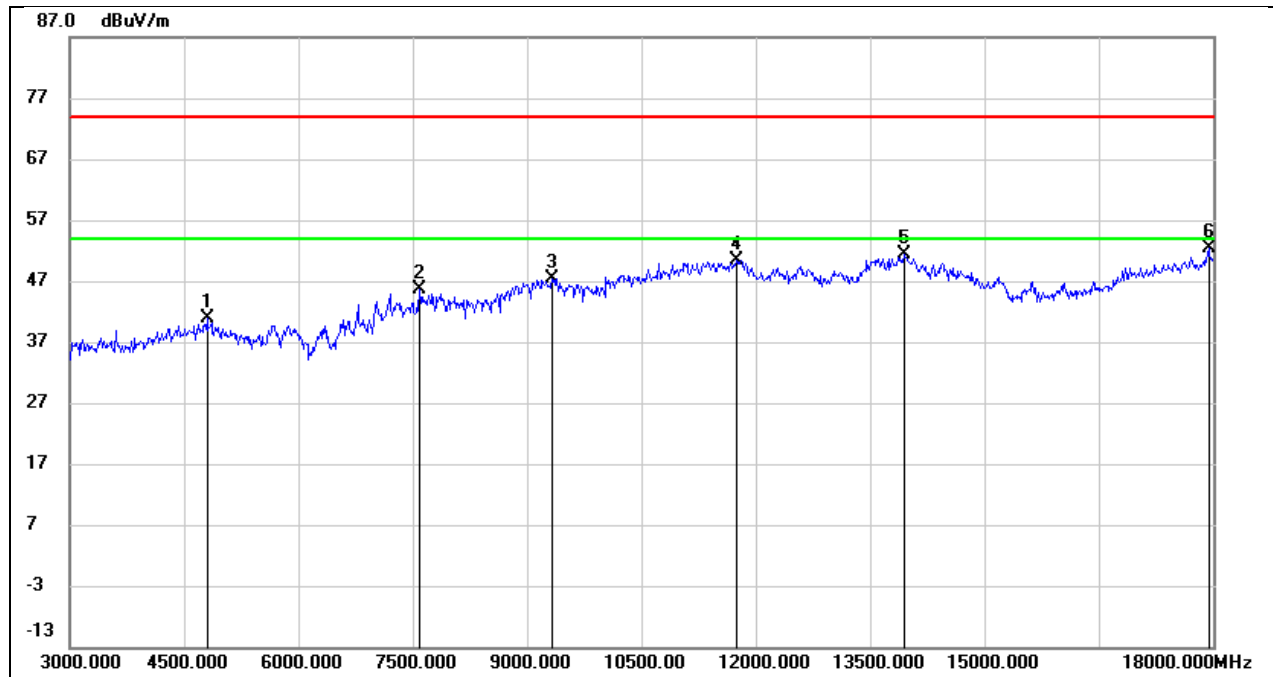

No.	Frequency (MHz)	Reading (dBuV)	Correct (dB/m)	Result (dBuV/m)	Limit (dBuV/m)	Margin (dB)	Remark
1	4800.000	41.08	-0.31	40.77	74.00	-33.23	peak
2	7590.000	39.20	6.32	45.52	74.00	-28.48	peak
3	9330.000	36.68	10.62	47.30	74.00	-26.70	peak
4	11745.000	33.20	17.27	50.47	74.00	-23.53	peak
5	13950.000	29.43	21.86	51.29	74.00	-22.71	peak
6	17940.000	27.11	25.34	52.45	74.00	-21.55	peak



Test Mode:	LE 1M	Channel:	2402 MHz
Polarity:	Vertical	Test Voltage:	DC 3.3 V

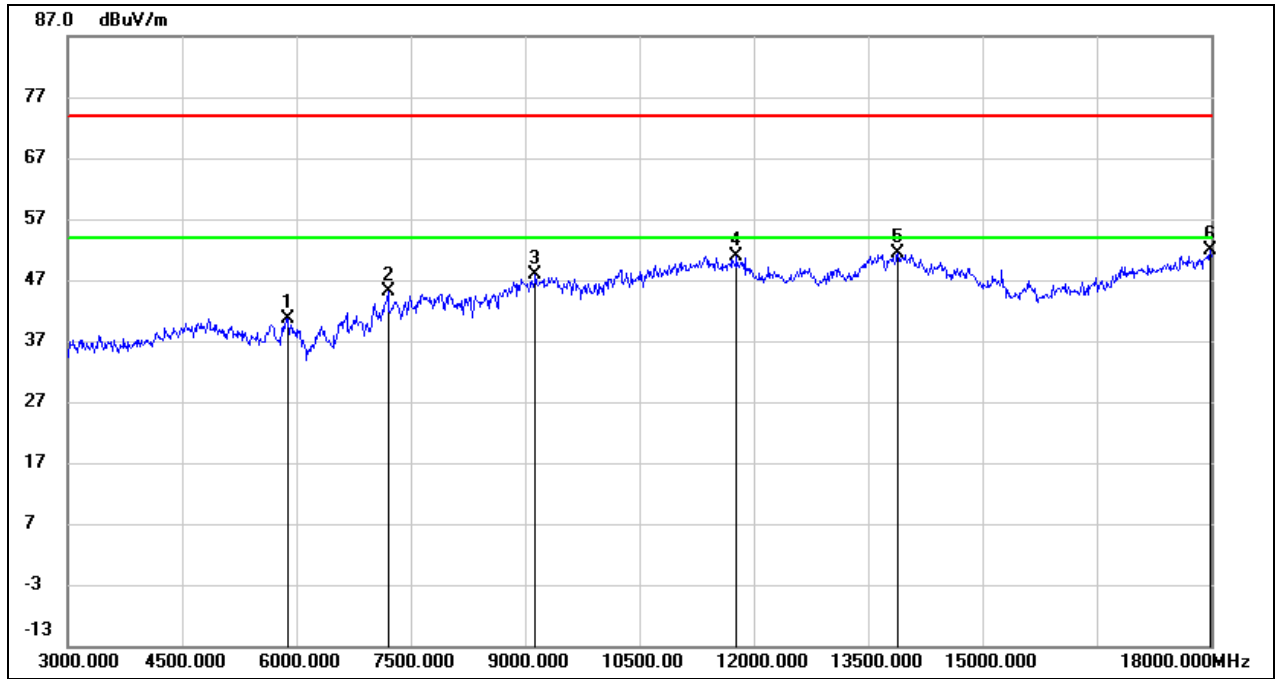

No.	Frequency (MHz)	Reading (dBuV)	Correct (dB/m)	Result (dBuV/m)	Limit (dBuV/m)	Margin (dB)	Remark
1	5895.000	38.77	1.96	40.73	74.00	-33.27	peak
2	7200.000	38.49	6.55	45.04	74.00	-28.96	peak
3	9135.000	37.33	10.55	47.88	74.00	-26.12	peak
4	11775.000	33.53	17.35	50.88	74.00	-23.12	peak
5	13890.000	29.60	21.72	51.32	74.00	-22.68	peak
6	17985.000	26.31	25.60	51.91	74.00	-22.09	peak



Test Mode:	LE 1M	Channel:	2440 MHz
Polarity:	Horizontal	Test Voltage:	DC 3.3 V

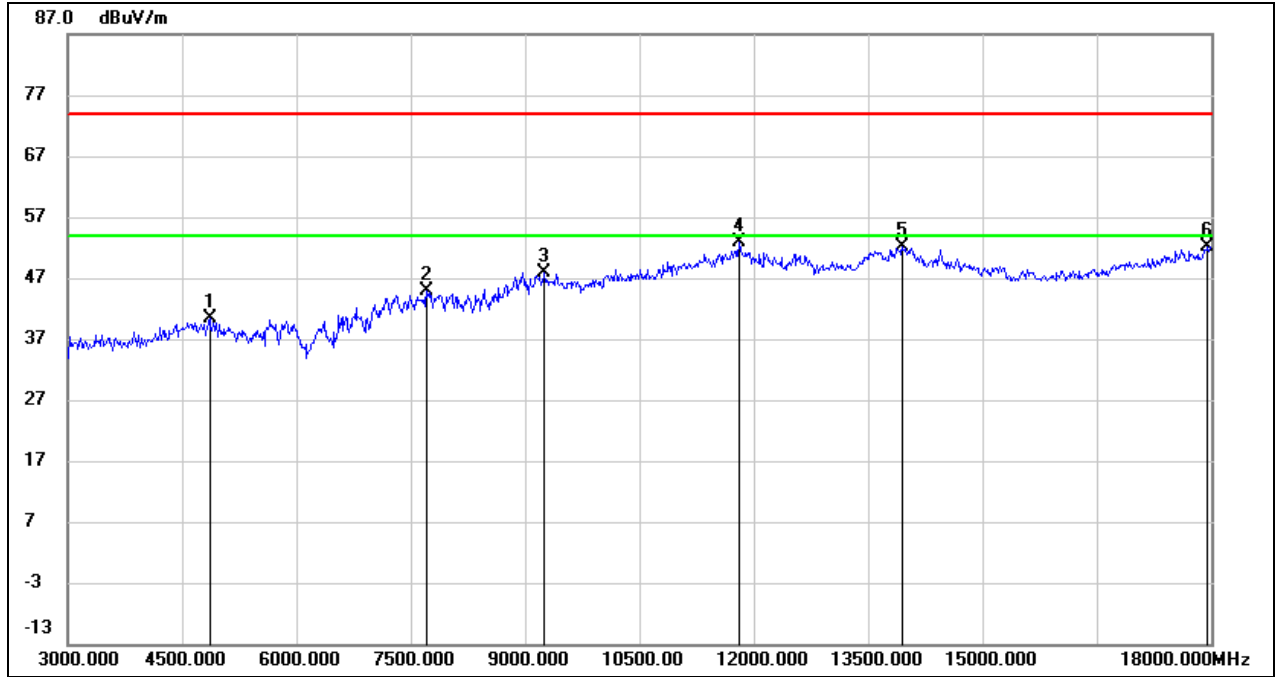

No.	Frequency (MHz)	Reading (dBuV)	Correct (dB/m)	Result (dBuV/m)	Limit (dBuV/m)	Margin (dB)	Remark
1	4860.000	40.42	-0.09	40.33	74.00	-33.67	peak
2	7710.000	38.48	6.33	44.81	74.00	-29.19	peak
3	9255.000	37.30	10.59	47.89	74.00	-26.11	peak
4	11805.000	35.43	17.43	52.86	74.00	-21.14	peak
5	13950.000	30.31	21.86	52.17	74.00	-21.83	peak
6	17955.000	26.80	25.42	52.22	74.00	-21.78	peak



Test Mode:	LE 1M	Channel:	2440 MHz
Polarity:	Vertical	Test Voltage:	DC 3.3 V

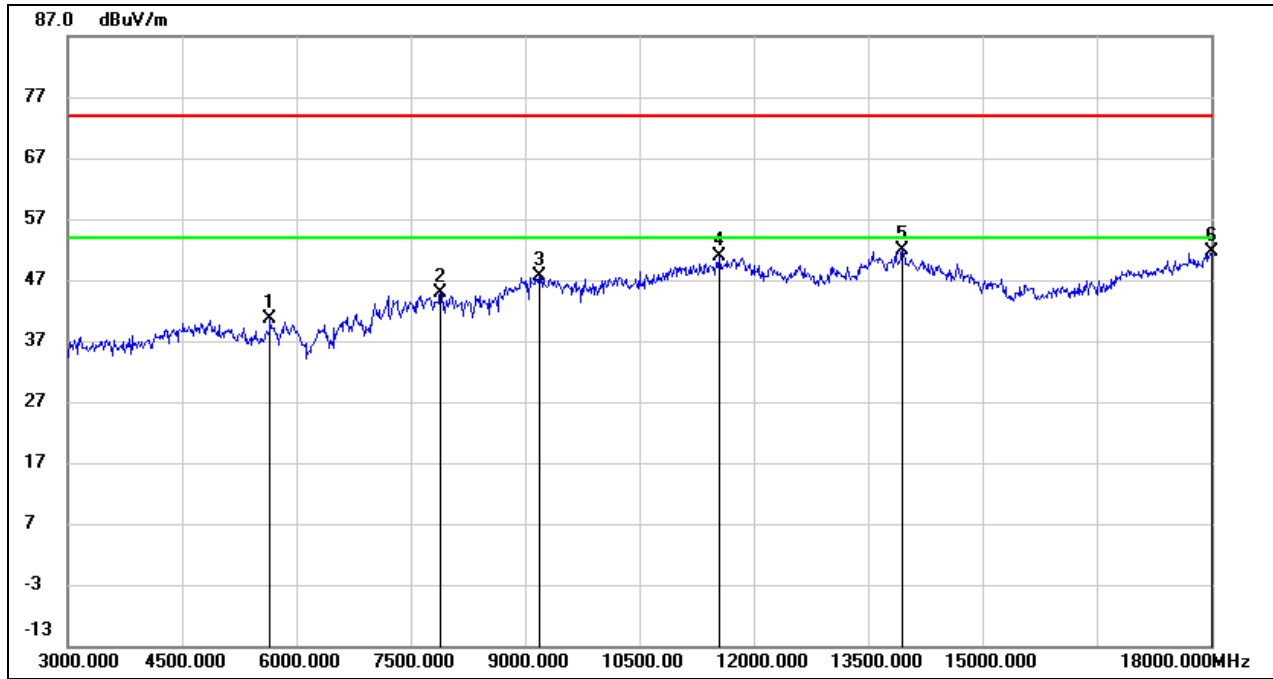

No.	Frequency (MHz)	Reading (dBuV)	Correct (dB/m)	Result (dBuV/m)	Limit (dBuV/m)	Margin (dB)	Remark
1	5655.000	39.33	1.29	40.62	74.00	-33.38	peak
2	7890.000	38.51	6.31	44.82	74.00	-29.18	peak
3	9180.000	37.05	10.56	47.61	74.00	-26.39	peak
4	11550.000	34.08	16.74	50.82	74.00	-23.18	peak
5	13950.000	30.14	21.86	52.00	74.00	-22.00	peak
6	18000.000	25.84	25.69	51.53	74.00	-22.47	peak



Test Mode:	LE 1M	Channel:	2480 MHz
Polarity:	Horizontal	Test Voltage:	DC 3.3 V

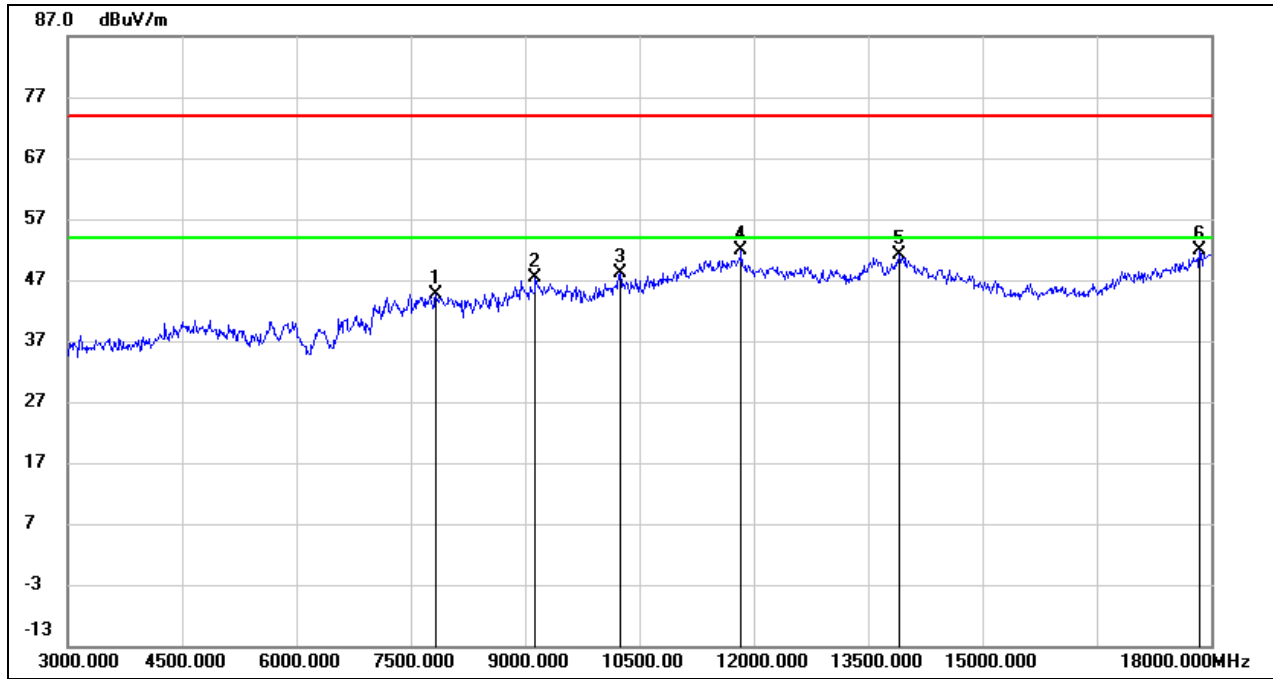

No.	Frequency (MHz)	Reading (dBuV)	Correct (dB/m)	Result (dBuV/m)	Limit (dBuV/m)	Margin (dB)	Remark
1	7830.000	38.38	6.32	44.70	74.00	-29.30	peak
2	9135.000	36.95	10.55	47.50	74.00	-26.50	peak
3	10245.000	35.71	12.48	48.19	74.00	-25.81	peak
4	11835.000	34.43	17.51	51.94	74.00	-22.06	peak
5	13905.000	29.38	21.76	51.14	74.00	-22.86	peak
6	17850.000	27.03	24.81	51.84	74.00	-22.16	peak



Test Mode:	LE 1M	Channel:	2480 MHz
Polarity:	Vertical	Test Voltage:	DC 3.3 V

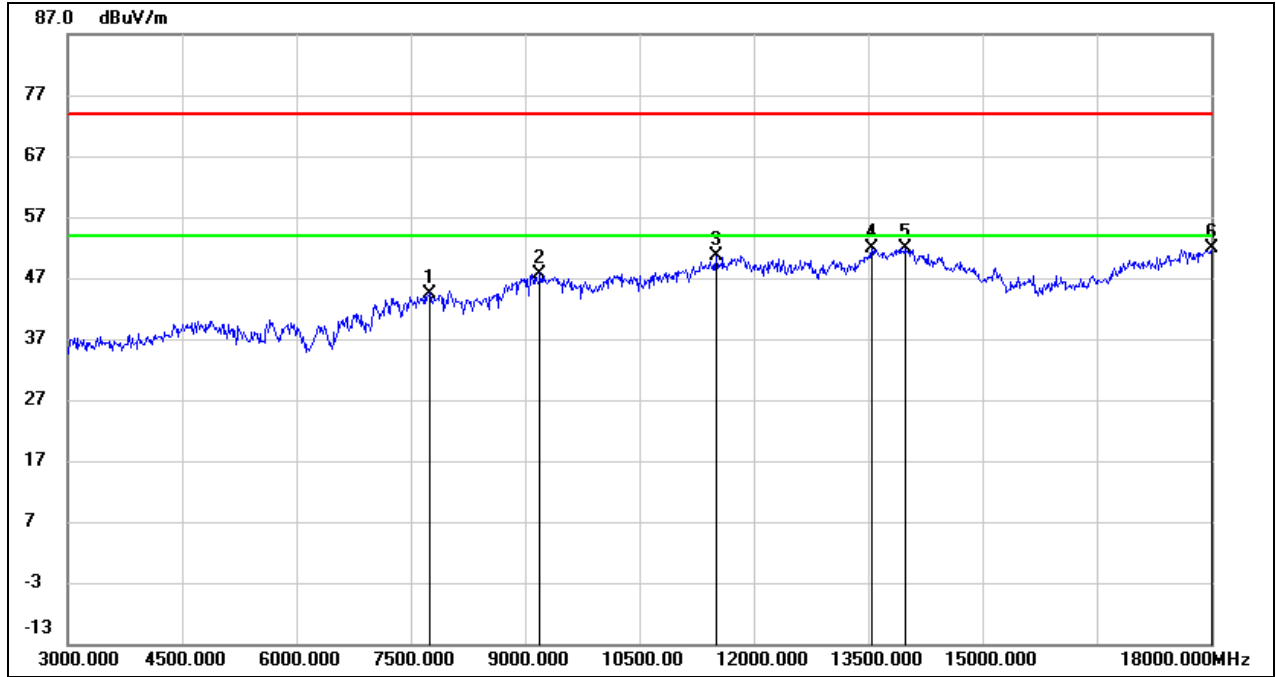

No.	Frequency (MHz)	Reading (dBuV)	Correct (dB/m)	Result (dBuV/m)	Limit (dBuV/m)	Margin (dB)	Remark
1	7755.000	38.19	6.31	44.50	74.00	-29.50	peak
2	9195.000	37.19	10.56	47.75	74.00	-26.25	peak
3	11505.000	34.13	16.61	50.74	74.00	-23.26	peak
4	13545.000	30.89	20.99	51.88	74.00	-22.12	peak
5	13980.000	29.86	21.92	51.78	74.00	-22.22	peak
6	18000.000	26.21	25.69	51.90	74.00	-22.10	peak





Test Mode:	LE 2M	Channel:	2402 MHz
Polarity:	Horizontal	Test Voltage:	DC 3.3 V

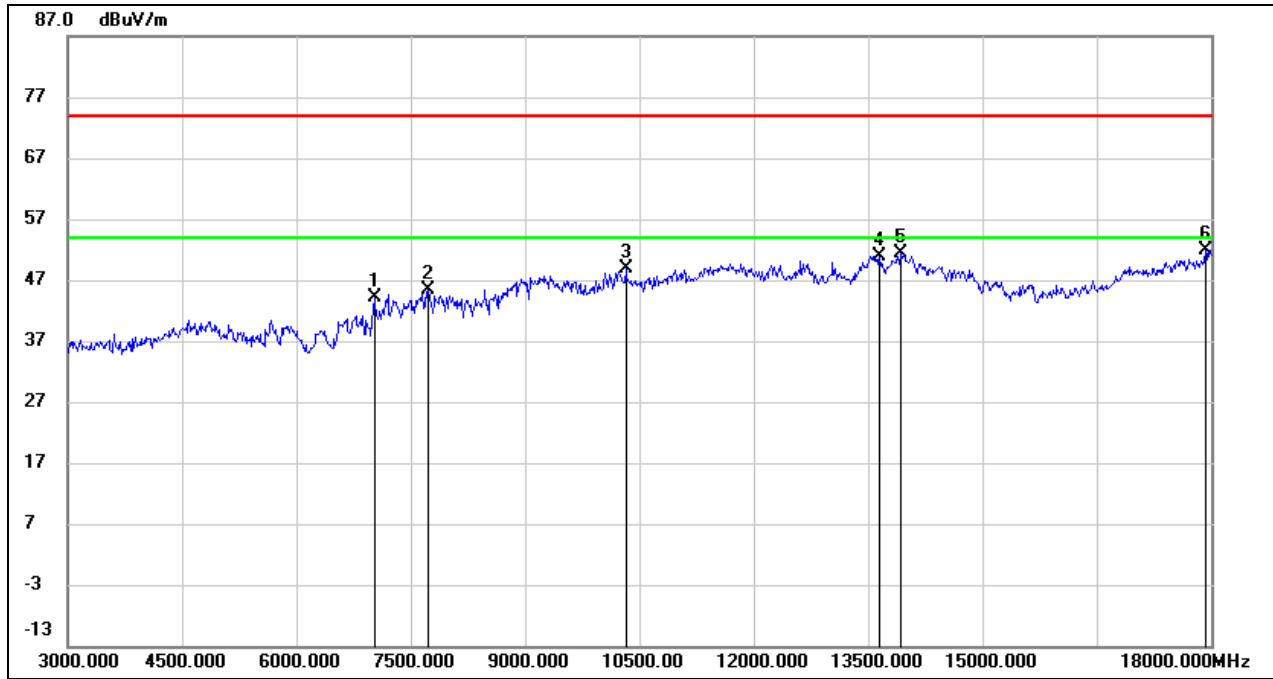

No.	Frequency (MHz)	Reading (dBuV)	Correct (dB/m)	Result (dBuV/m)	Limit (dBuV/m)	Margin (dB)	Remark
1	7020.000	37.36	6.67	44.03	74.00	-29.97	peak
2	7725.000	39.12	6.32	45.44	74.00	-28.56	peak
3	10320.000	36.23	12.64	48.87	74.00	-25.13	peak
4	13650.000	29.73	21.21	50.94	74.00	-23.06	peak
5	13920.000	29.56	21.79	51.35	74.00	-22.65	peak
6	17925.000	26.70	25.25	51.95	74.00	-22.05	peak



Test Mode:	LE 2M	Channel:	2402 MHz
Polarity:	Vertical	Test Voltage:	DC 3.3 V

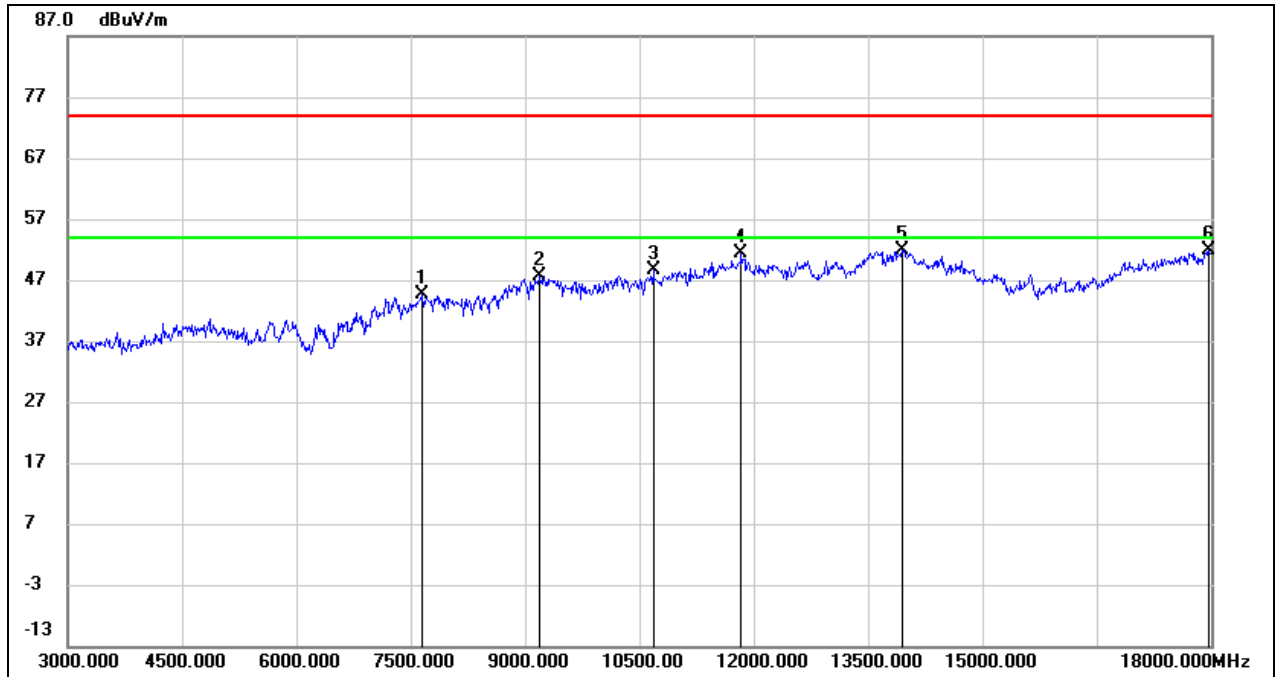

No.	Frequency (MHz)	Reading (dBuV)	Correct (dB/m)	Result (dBuV/m)	Limit (dBuV/m)	Margin (dB)	Remark
1	7650.000	38.38	6.33	44.71	74.00	-29.29	peak
2	9180.000	37.15	10.56	47.71	74.00	-26.29	peak
3	10680.000	35.03	13.62	48.65	74.00	-25.35	peak
4	11835.000	33.80	17.51	51.31	74.00	-22.69	peak
5	13950.000	30.08	21.86	51.94	74.00	-22.06	peak
6	17970.000	26.44	25.51	51.95	74.00	-22.05	peak



Test Mode:	LE 2M	Channel:	2440 MHz
Polarity:	Horizontal	Test Voltage:	DC 3.3 V

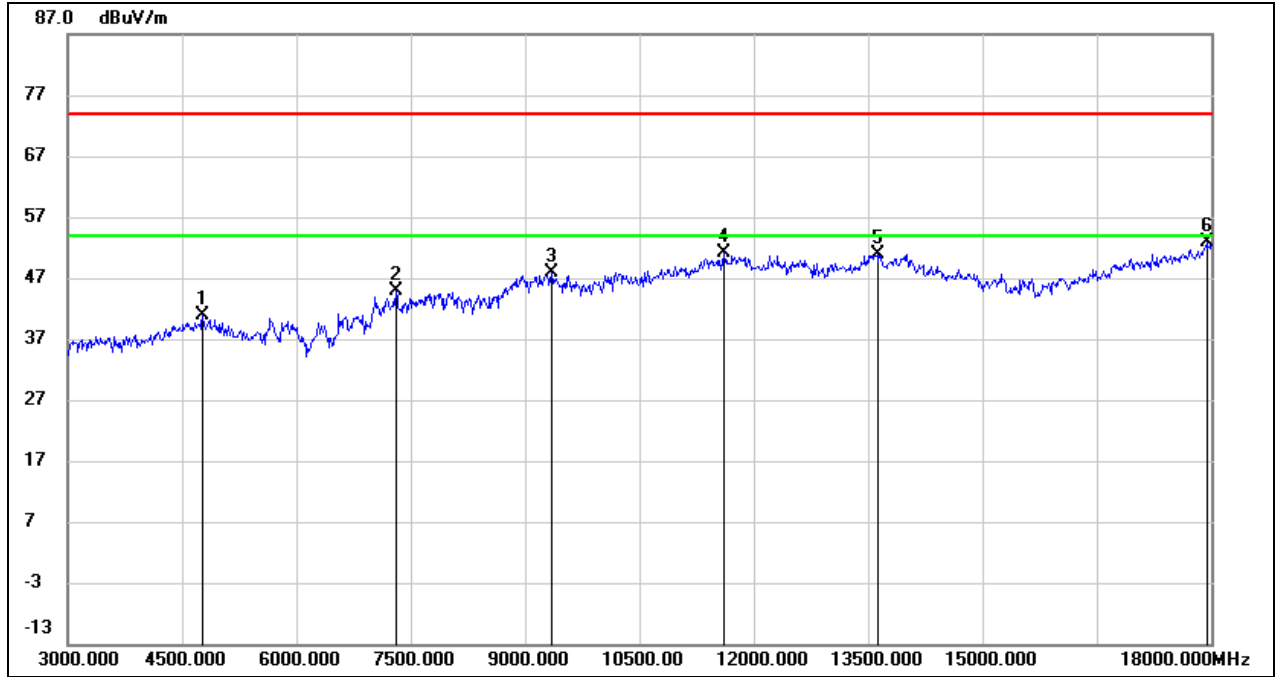

No.	Frequency (MHz)	Reading (dBuV)	Correct (dB/m)	Result (dBuV/m)	Limit (dBuV/m)	Margin (dB)	Remark
1	4770.000	41.34	-0.43	40.91	74.00	-33.09	peak
2	7305.000	38.49	6.47	44.96	74.00	-29.04	peak
3	9345.000	37.32	10.63	47.95	74.00	-26.05	peak
4	11610.000	34.29	16.90	51.19	74.00	-22.81	peak
5	13620.000	29.64	21.15	50.79	74.00	-23.21	peak
6	17940.000	27.47	25.34	52.81	74.00	-21.19	peak



Test Mode:	LE 2M	Channel:	2440 MHz
Polarity:	Vertical	Test Voltage:	DC 3.3 V

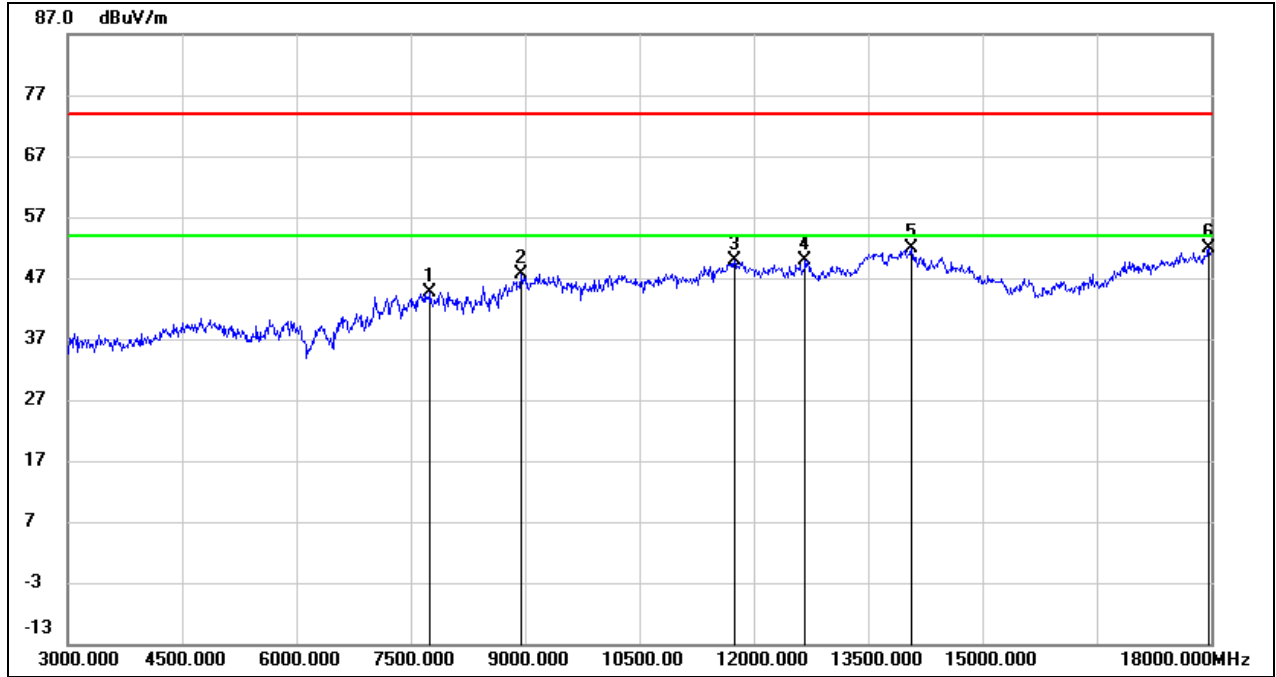

No.	Frequency (MHz)	Reading (dBuV)	Correct (dB/m)	Result (dBuV/m)	Limit (dBuV/m)	Margin (dB)	Remark
1	7755.000	38.41	6.31	44.72	74.00	-29.28	peak
2	8940.000	37.69	10.04	47.73	74.00	-26.27	peak
3	11745.000	32.50	17.27	49.77	74.00	-24.23	peak
4	12675.000	31.99	17.99	49.98	74.00	-24.02	peak
5	14070.000	30.09	21.67	51.76	74.00	-22.24	peak
6	17970.000	26.33	25.51	51.84	74.00	-22.16	peak



Test Mode:	LE 2M	Channel:	2480 MHz
Polarity:	Horizontal	Test Voltage:	DC 3.3 V

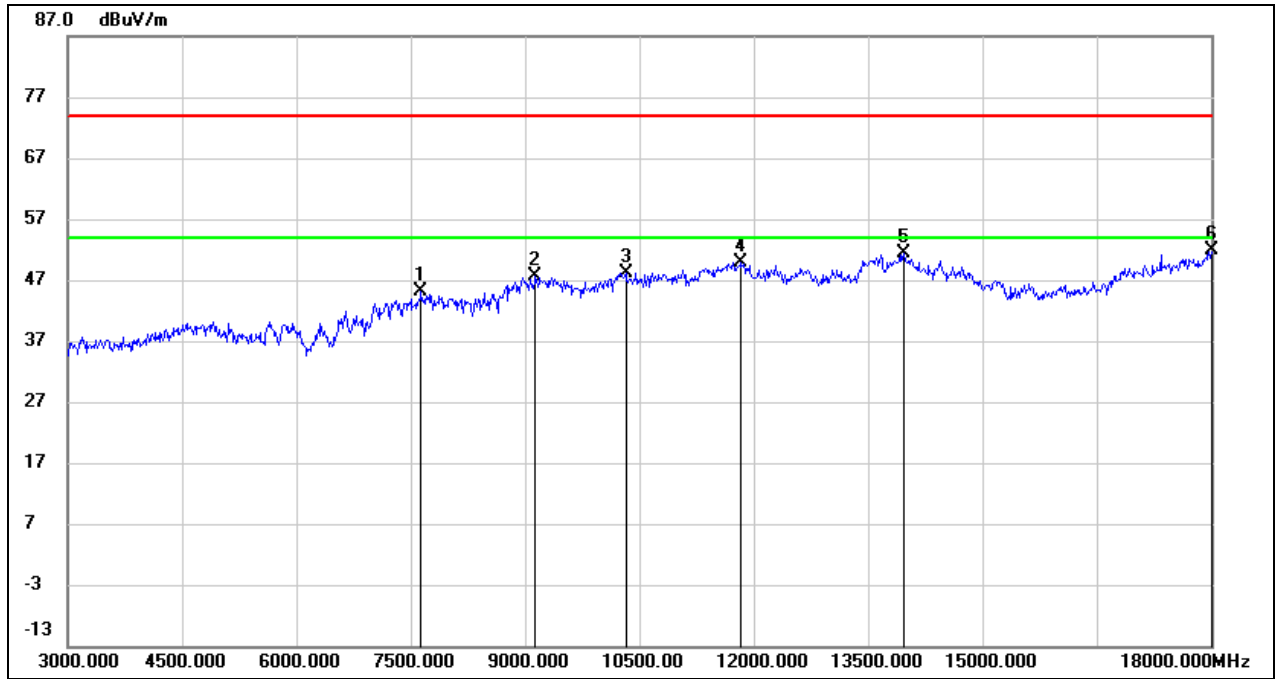

No.	Frequency (MHz)	Reading (dBuV)	Correct (dB/m)	Result (dBuV/m)	Limit (dBuV/m)	Margin (dB)	Remark
1	7635.000	38.74	6.33	45.07	74.00	-28.93	peak
2	9135.000	36.99	10.55	47.54	74.00	-26.46	peak
3	10320.000	35.42	12.64	48.06	74.00	-25.94	peak
4	11835.000	32.29	17.51	49.80	74.00	-24.20	peak
5	13965.000	29.44	21.89	51.33	74.00	-22.67	peak
6	18000.000	26.28	25.69	51.97	74.00	-22.03	peak



Test Mode:	LE 2M	Channel:	2480 MHz
Polarity:	Vertical	Test Voltage:	DC 3.3 V

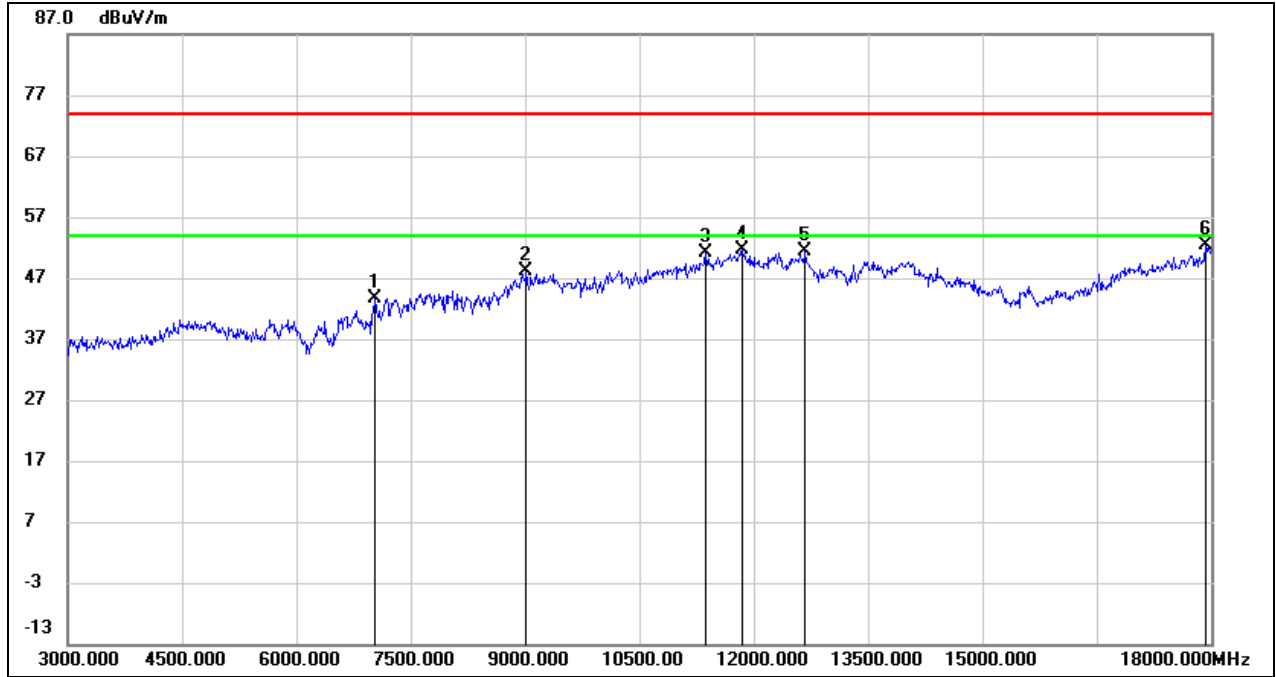

No.	Frequency (MHz)	Reading (dBuV)	Correct (dB/m)	Result (dBuV/m)	Limit (dBuV/m)	Margin (dB)	Remark
1	7035.000	36.98	6.67	43.65	74.00	-30.35	peak
2	9015.000	37.59	10.49	48.08	74.00	-25.92	peak
3	11370.000	35.09	16.12	51.21	74.00	-22.79	peak
4	11850.000	34.08	17.56	51.64	74.00	-22.36	peak
5	12675.000	33.28	17.99	51.27	74.00	-22.73	peak
6	17925.000	27.12	25.25	52.37	74.00	-21.63	peak



## 8.4. SPURIOUS EMISSIONS (9 KHZ ~ 30 MHZ)

Test Mode:	LE 1M	Channel:	2402 MHz
Polarity:	Loop Antenna Face On To The EUT	Test Voltage:	DC 3.3 V

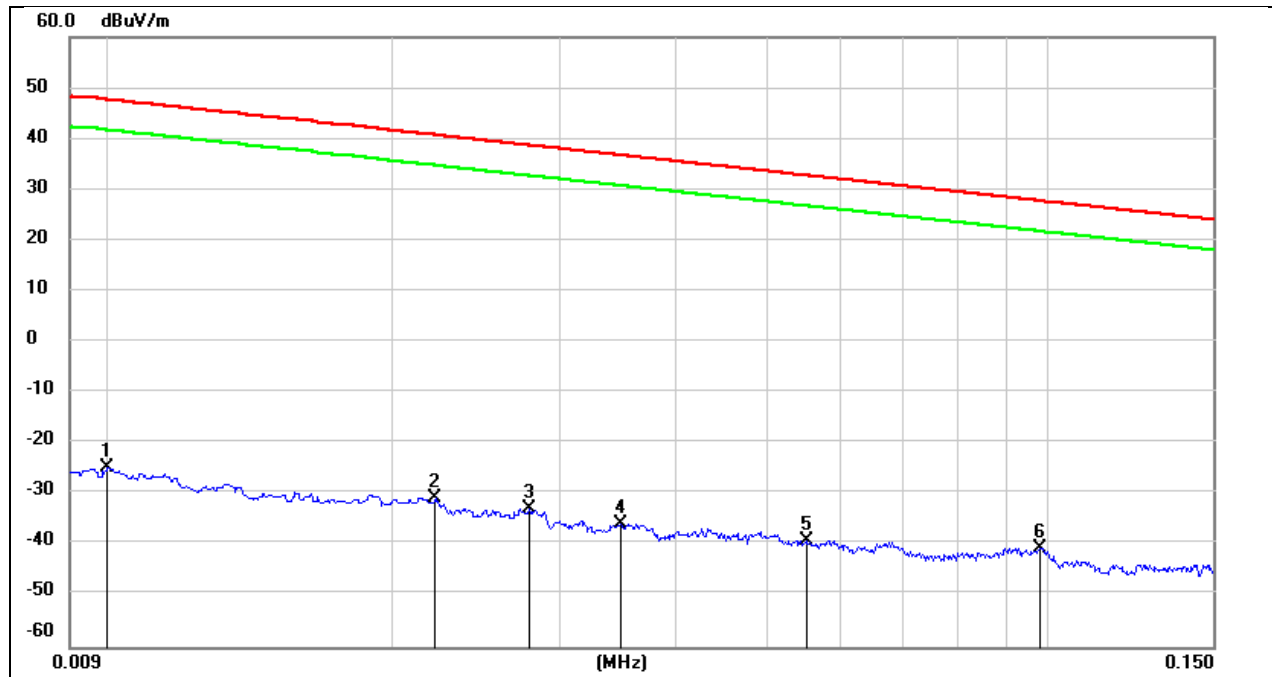

No.	Frequency (MHz)	Reading (dBuV)	Correct (dB/m)	Result (dBuV/m)	Limit (dBuV/m)	Margin (dB)	Remark
1	0.0100	76.72	-101.40	-24.68	47.60	-72.28	peak
2	0.0221	70.63	-101.35	-30.72	40.71	-71.43	peak
3	0.0279	68.67	-101.38	-32.71	38.69	-71.40	peak
4	0.0349	65.53	-101.41	-35.88	36.75	-72.63	peak
5	0.0551	62.45	-101.50	-39.05	32.78	-71.83	peak
6	0.0981	61.27	-101.78	-40.51	27.77	-68.28	peak



Test Mode:	LE 1M	Channel:	2402 MHz
Polarity:	Loop Antenna Face On To The EUT	Test Voltage:	DC 3.3 V

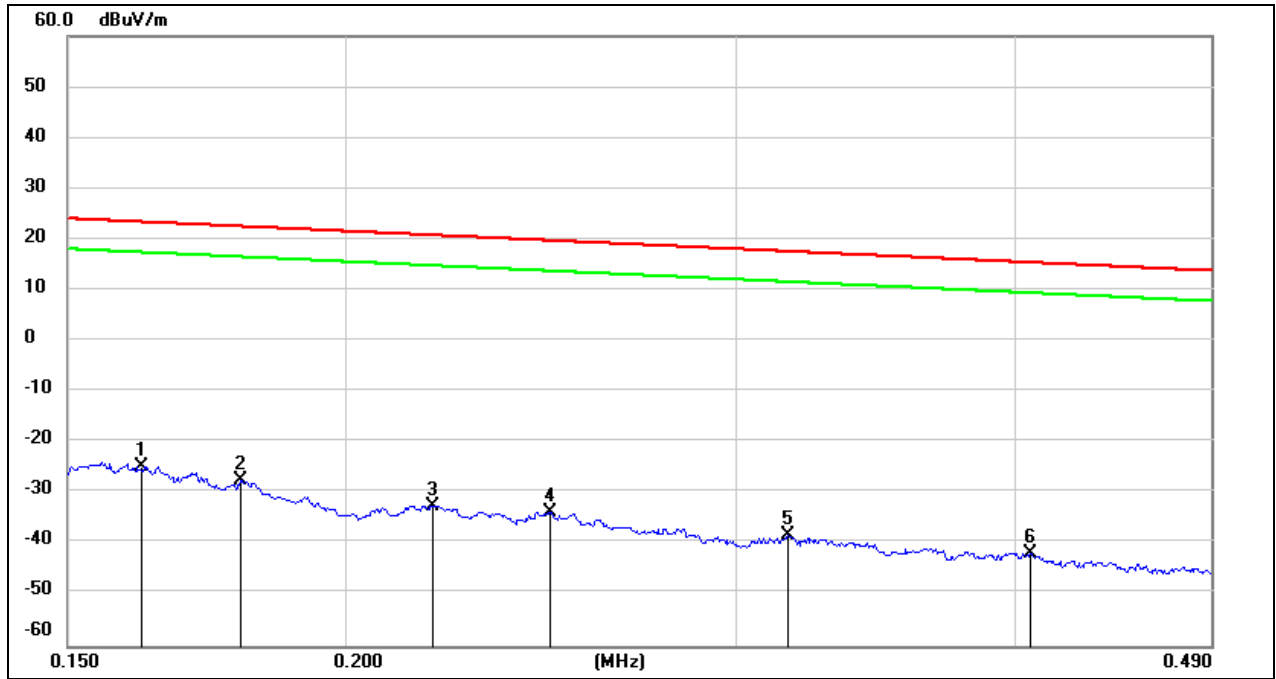

No.	Frequency (MHz)	Reading (dBuV)	Correct (dB/m)	Result (dBuV/m)	Limit (dBuV/m)	Margin (dB)	Remark
1	0.1621	76.92	-101.65	-24.73	23.41	-48.14	peak
2	0.1794	74.27	-101.68	-27.41	22.53	-49.94	peak
3	0.2190	69.27	-101.75	-32.48	20.79	-53.27	peak
4	0.2472	67.95	-101.80	-33.85	19.74	-53.59	peak
5	0.3163	63.70	-101.87	-38.17	17.60	-55.77	peak
6	0.4062	60.14	-101.96	-41.82	15.43	-57.25	peak





Test Mode:	LE 1M	Channel:	2402 MHz
Polarity:	Loop Antenna Face On To The EUT	Test Voltage:	DC 3.3 V

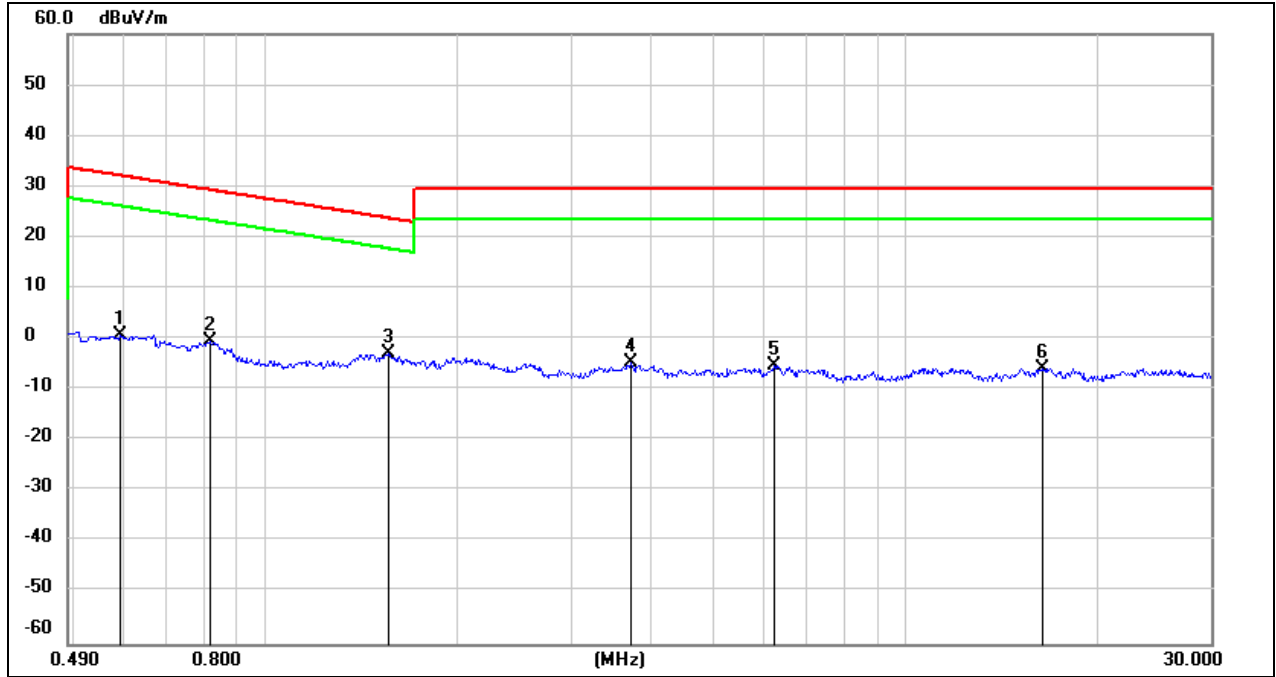

No.	Frequency (MHz)	Reading (dBuV)	Correct (dB/m)	Result (dBuV/m)	Limit (dBuV/m)	Margin (dB)	Remark
1	0.5917	62.74	-62.08	0.66	32.16	-31.50	peak
2	0.8195	61.66	-62.16	-0.50	29.33	-29.83	peak
3	1.5564	59.18	-62.02	-2.84	23.76	-26.60	peak
4	3.7100	56.70	-61.41	-4.71	29.54	-34.25	peak
5	6.2445	56.13	-61.32	-5.19	29.54	-34.73	peak
6	16.3959	55.17	-60.96	-5.79	29.54	-35.33	peak



### 8.5. SPURIOUS EMISSIONS (30 MHZ ~ 1 GHZ)

Test Mode:	LE 1M	Channel:	2402 MHz
Polarity:	Horizontal	Test Voltage:	DC 3.3 V

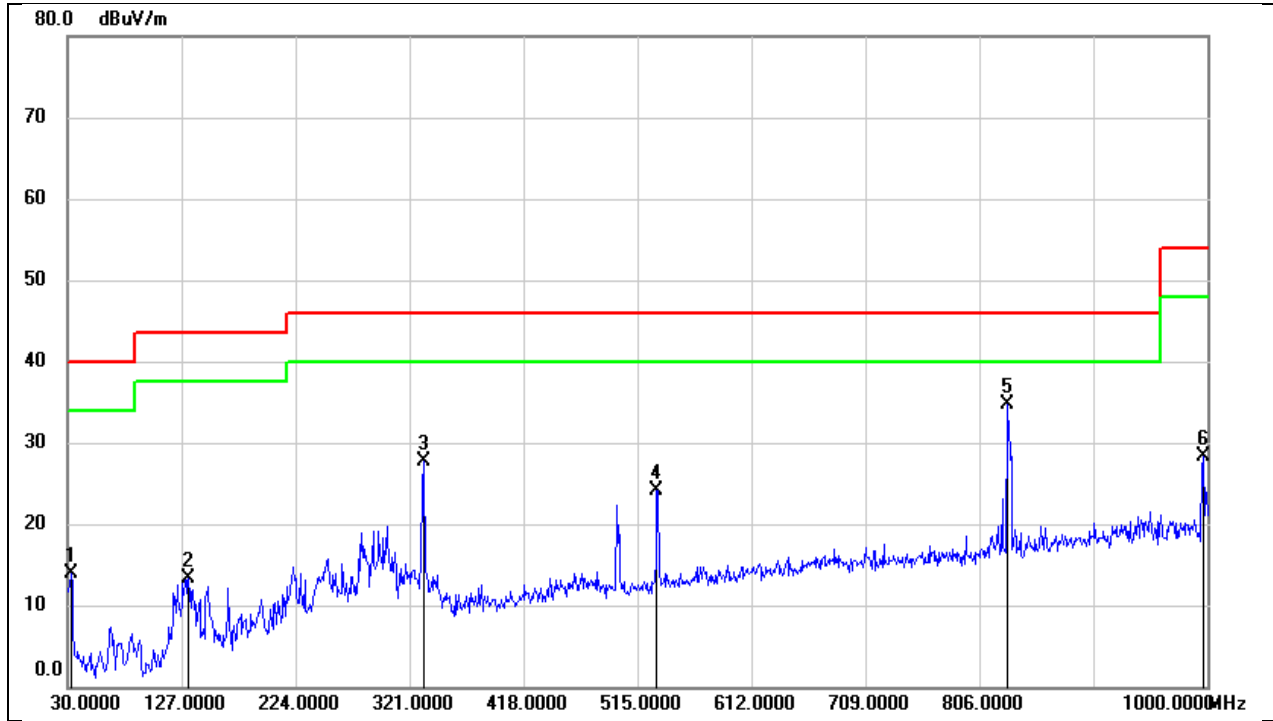

No.	Frequency (MHz)	Reading (dBuV)	Correct (dB/m)	Result (dBuV/m)	Limit (dBuV/m)	Margin (dB)	Remark
1	32.9100	33.09	-19.22	13.87	40.00	-26.13	QP
2	132.8200	32.50	-19.20	13.30	43.50	-30.20	QP
3	333.6099	42.29	-14.59	27.70	46.00	-18.30	QP
4	531.4900	34.93	-10.76	24.17	46.00	-21.83	QP
5	829.2800	41.40	-6.69	34.71	46.00	-11.29	QP
6	997.0900	32.41	-4.18	28.23	54.00	-25.77	QP



Test Mode:	LE 1M	Channel:	2402 MHz
Polarity:	Vertical	Test Voltage:	DC 3.3 V

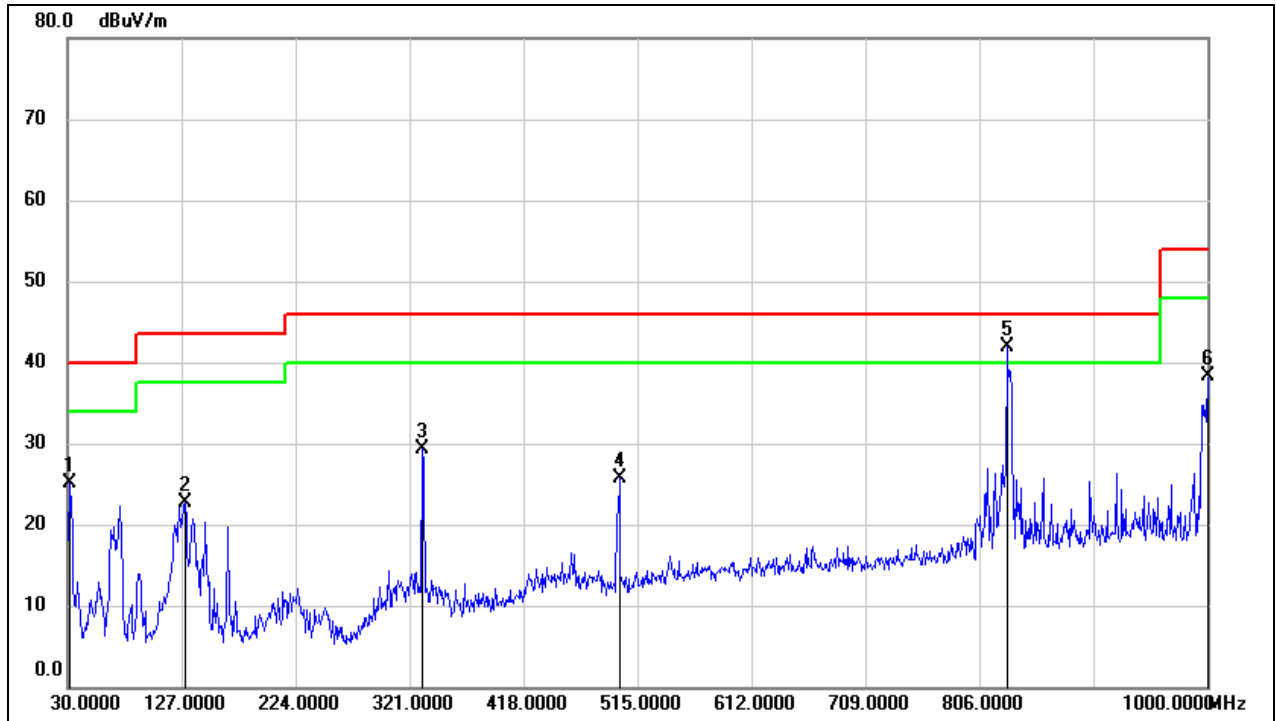

No.	Frequency (MHz)	Reading (dBuV)	Correct (dB/m)	Result (dBuV/m)	Limit (dBuV/m)	Margin (dB)	Remark
1	31.9400	44.22	-19.13	25.09	40.00	-14.91	QP
2	129.9100	42.03	-19.36	22.67	43.50	-20.83	QP
3	331.6700	43.87	-14.64	29.23	46.00	-16.77	QP
4	499.4800	37.21	-11.48	25.73	46.00	-20.27	QP
5	829.2800	48.59	-6.69	41.90	46.00	-4.10	QP
6	1000.0000	42.42	-4.15	38.27	54.00	-15.73	QP

**8.6. SPURIOUS EMISSIONS (18 GHZ ~ 26 GHZ)**

Test Mode:	LE 1M	Channel:	2402 MHz
Polarity:	Horizontal	Test Voltage:	DC 3.3 V

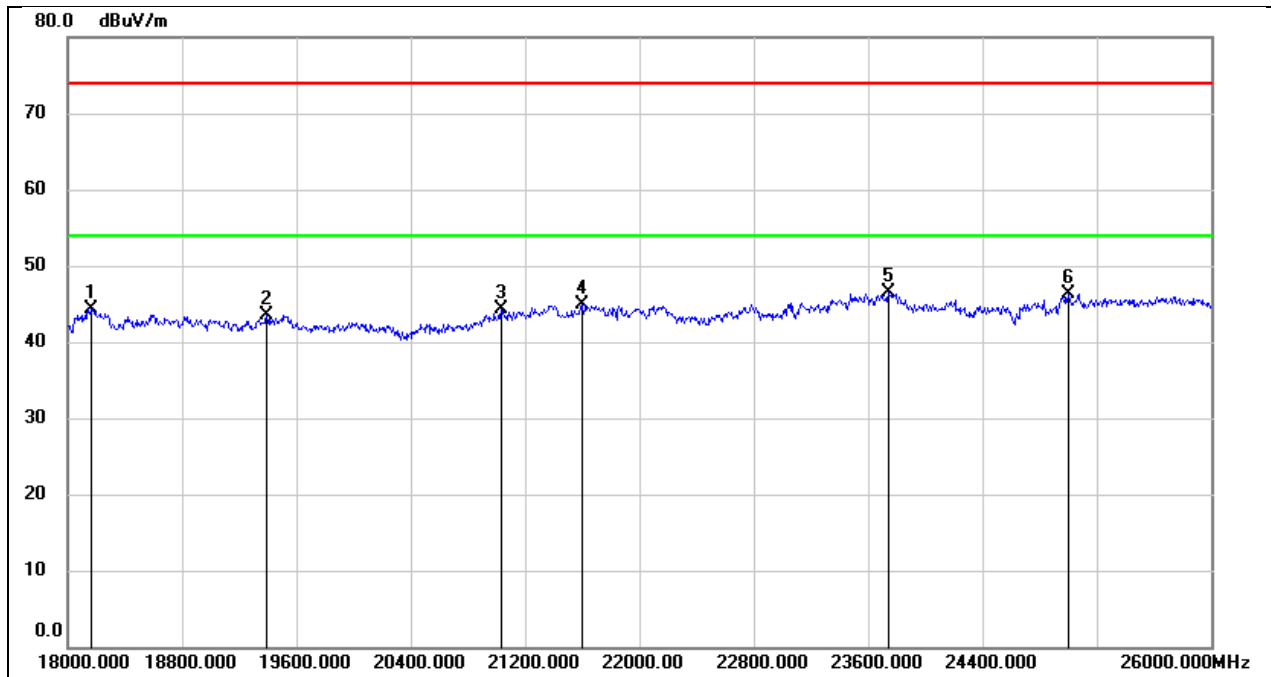

No.	Frequency (MHz)	Reading (dBuV)	Correct (dB/m)	Result (dBuV/m)	Limit (dBuV/m)	Margin (dB)	Remark
1	18168.000	49.76	-5.50	44.26	74.00	-29.74	peak
2	19392.000	49.12	-5.57	43.55	74.00	-30.45	peak
3	21032.000	49.15	-4.87	44.28	74.00	-29.72	peak
4	21600.000	49.52	-4.54	44.98	74.00	-29.02	peak
5	23744.000	49.65	-3.20	46.45	74.00	-27.55	peak
6	25000.000	48.36	-2.10	46.26	74.00	-27.74	peak



Test Mode:	LE 1M	Channel:	2402 MHz
Polarity:	Vertical	Test Voltage:	DC 3.3 V

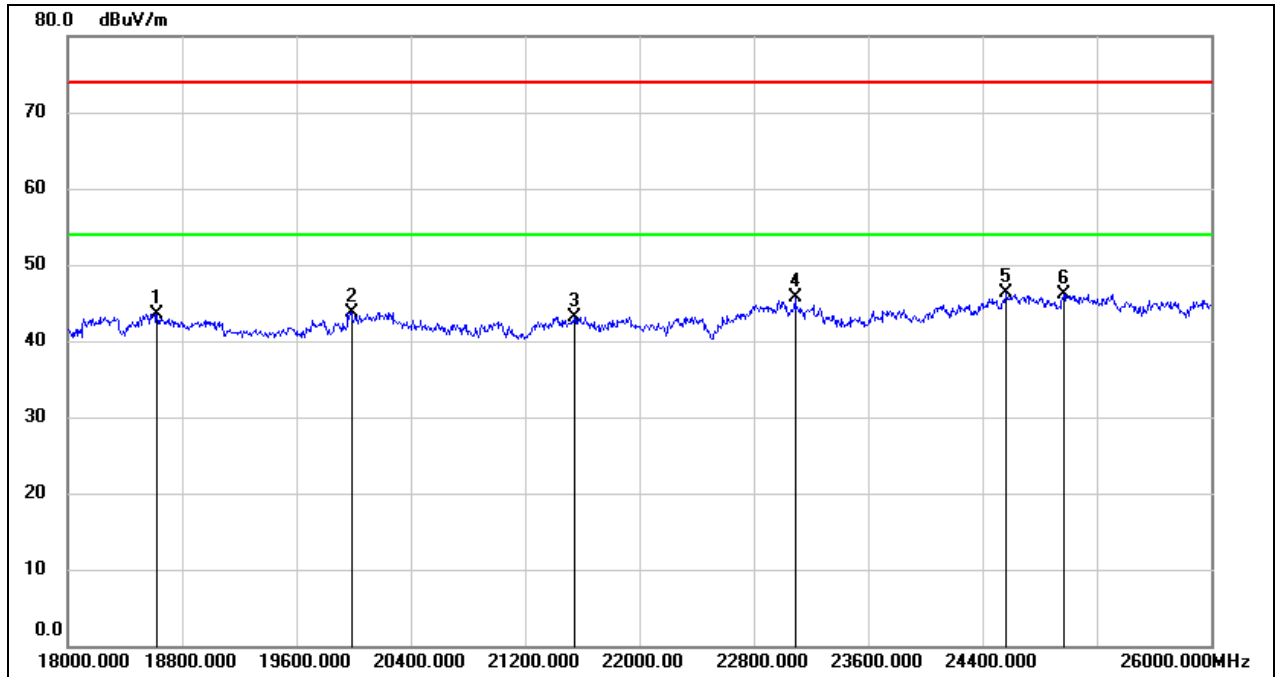

No.	Frequency (MHz)	Reading (dBuV)	Correct (dB/m)	Result (dBuV/m)	Limit (dBuV/m)	Margin (dB)	Remark
1	18624.000	48.83	-5.34	43.49	74.00	-30.51	peak
2	19984.000	49.21	-5.44	43.77	74.00	-30.23	peak
3	21544.000	47.76	-4.63	43.13	74.00	-30.87	peak
4	23088.000	49.02	-3.41	45.61	74.00	-28.39	peak
5	24568.000	48.60	-2.33	46.27	74.00	-27.73	peak
6	24968.000	48.26	-2.14	46.12	74.00	-27.88	peak



## 9. ANTENNA REQUIREMENTS

### APPLICABLE REQUIREMENTS

Please refer to FCC §15.203

An intentional radiator shall be designed to ensure that no antenna other than that furnished by the responsible party shall be used with the device. The use of a permanently attached antenna or of an antenna that uses a unique coupling to the intentional radiator shall be considered sufficient to comply with the provisions of this section. The manufacturer may design the unit so that a broken antenna can be replaced by the user, but the use of a standard antenna jack or electrical connector is prohibited.

Please refer to FCC §15.247(b)(4)

The conducted output power limit specified in paragraph (b) of this section is based on the use of antennas with directional gains that do not exceed 6 dBi. Except as shown in paragraph (c) of this section, if transmitting antennas of directional gain greater than 6 dBi are used, the conducted output power from the intentional radiator shall be reduced below the stated values in paragraphs (b)(1), (b)(2), and (b)(3) of this section, as appropriate, by the amount in dB that the directional gain of the antenna exceeds 6 dBi.

### RESULTS

Complies

---

**END OF REPORT**