

# E01003 USER MANUAL

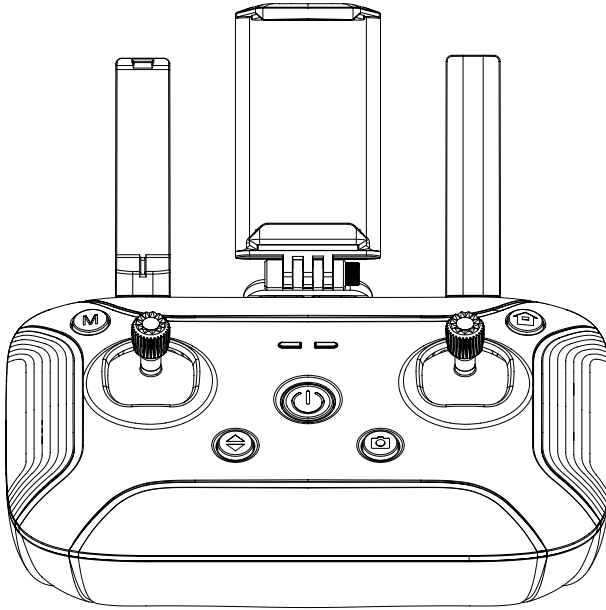

## ***IMPORTANT***

- *Before using the product, please carefully read this manual and strictly comply with the operating instructions.*
- *Do not attempt to disassemble, modify or repair the aircraft. If necessary, please contact your local retailer.*
- *All the contents of this manual are subject to change without prior notice.*

# I. Important Notice

## 1. Flight Safety Instructions

- (1) This product is not a toy, not intended for children under 14 years.
- (2) Please familiarize yourself with the relevant local laws and regulations. And keep away from any non-flight zones.
- (3) Please keep the aircraft within visual line of sight. DO NOT fly over obstacles, otherwise the drone may lose control and have serious damages.
- (4) Please keep the remote controller and the mobile device handy during the operation to avoid accidents.
- (5) Please keep yourself and other objects away from the drone when it is in motion.
- (6) Please turn off the aircraft and the remote controller immediately when the drone stops flying.
- (7) Please strictly adhere to the safety instructions when using the lithium battery. Never leave the battery unattended while charging to avoid accidents.
- (8) DO NOT fly the drone or use any type of remote controller within a radius of 500 meters of an airport. DO NOT use the remote controller when and where the radio restrictions may apply.

## 2. Flight Environment

- (1) Choose a wide open space without obstacles. Do not operate near buildings, trees, high voltage cables, crowds of people or animals.
- (2) Do not fly in bad weather, such as windy, rainy, snowy and foggy weather.
- (3) Do not fly near tall buildings, high-voltage cables, communication base stations and Wi-Fi hotspots, which will severely affect the signal receiving of the aircraft, resulting in abnormal data and accidents.
- (4) Do not contact the propeller in motion, otherwise it might cause serious injury. Safety is the priority for both you and your surrounding environment and people. Therefore, please navigate to the APP and download the disclaimer and read it through.

# II. Battery Usage

**Warning:** Please read through this manual and familiarize yourself with the functions of the product before using it. Improper operation may cause serious injury, damage to product or property loss.

*This product requires sophisticated pilots with experienced operation and basic common sense. Please be aware of the safety of the flight. Improper operation may cause serious injury, damage to product or property loss.*

*This product is not intended for children. Do not use components that are not provided or recommended by us. Please adhere to the instructions for product installation and usage. Do not use other accessories or parts that are not recommended. This user manual includes safety, operation and maintenance instructions.*

*Please read the instructions and warning tips carefully before assembling, setting up and using this product. Improper usage, charging or battery storage may cause fire, property loss or personal injury. Please adhere to the following instructions for battery usage.*

## 1. Usage

- (1) Do not immerse the battery with the liquid such as water. Do not use the battery in humid environment. If the battery comes into contact with water, chemical decomposition may occur, resulting in the battery catching on fire and even leading to explosion.

- (2) Do not use other batteries but the specific battery. Other batteries may cause damage to the product or flight failure and even accidents. For replacement, please contact the local retailer for additional information.
- (3) Do not use batteries if they are dilatant or leaking, or the package damaged. If any of such battery problems occur, please contact the retailer or distributor.
- (4) Do not strike the battery against hard surface. Do not put objects over the battery or the charger.
- (5) The optimal temperature for battery usage should be between 0 C to 40 C . Excessive temperature (higher than 50 C ) may result the battery catching on fire and even lead to explosion. Low temperature (lower than 0 C ) may reduce the battery life.
- (6) Do not use the battery in an environment subject to strong static electricity or magnetic fields, otherwise the battery protection board may be damaged, resulting in flight failure.
- (7) Do not attempt to take a battery apart or stab a battery. It will catch on fire or explode.
- (8) The battery contains organic electrolyte. If electrolyte leakage occurs, please wash your eyes with clean water for at least 15 minutes and seek medical care immediately.
- (9) Do not use the battery that falls or collapses.
- (10) If the battery falls into the water with the aircraft, please immediately take out the battery and put it in a safe and open area. Never use the battery again, and dispose the battery properly as described in the Disposal section below. If the battery catches fire, use fire extinguisher to cool the battery. Other objects are recommended in the following priority order: sands, blanket, dry power and carbon dioxide extinguisher.
- (11) Do not put the battery in a microwave oven or a pressure cooker.
- (12) Do not put the battery cell near the surface of the electrical conductor.
- (13) Do not contact the two terminals to conductive wire or any metal objects to avoid battery short-circuit.
- (14) If there are contaminants on the charging interface, please clean them with dry cloth, otherwise it may result in poor contact and lead to power loss or charging failure.

## 2. Charging

- (1) Please charge the battery using the specific charger. Using other chargers may cause damage to the product and even lead to accidents. We shall not bear the responsibility for consequences resulting from improper charging.
- (2) Do not charge the battery next to flammable or on the surface of electro-conductive objects (places like cement ground is suggestive). When charging, please observe the battery at all times.
- (3) Do not charge the battery immediately when the battery is not cooled down yet. The optimal charging temperature should be between 5 C to 40 C , which helps extend battery lifespan.
- (4) Please disconnect the charger and the battery once the charging completes. Regularly inspect and maintain the charger. Do not use the charger if is outworn.

## 3. Storage and Transport

- (1) Keep batteries out of the reach of children. If the child has swallowed a battery, please seek medical care as soon as possible.
- (2) Do not store the battery next to heat sources, such as direct sunlight, carriage, fire or hot oven. The optimal storage temperature should be between 22 C to 28 C .
- (3) Storing batteries in dry environment. Do not immerse the battery with the liquid.
- (4) Do not strike, step on or stab a battery. Do not throw or short circuit a battery.
- (5) Do not store or transport the battery with glasses, watches, metal necklaces, hairpins or any other metal objects.
- (6) Do not transport the outworn batteries. If needed, discharge the batteries to 30%.
- (7) Please discharge the battery to 40% to 65% if not in use for over 10 days as to extend the battery lifespan.
- (8) Do not completely discharge the battery before storing it for long period of time, to avoid cell damage.

## 4. Disposal

- (1) Please completely discharge the battery and put the unusable batteries into the designated container. The battery contains electronic elements. Do not deal with the related equipment as daily rubbish.
- (2) If the battery has become unusable after discharging, please dispose it properly according to the local garbage disposal method.

## 5. Maintenance

- (1) Do not use the charger when the temperature is too high or too low.
- (2) Do not store the battery where the temperature is lower than 60 °C .
- (3) Do not over discharge the battery to avoid damage to the battery cell.
- (4) The battery's performance is likely to be affected if not in use for a long time.
- (5) Please discharge and recharge the battery every three months.

## 6. Notice

- (1) If you carry the batteries in your carry-on luggage in the airplane, please discharge the battery to 5%.
- (2) Store the battery in a well-ventilated place.

## III. Disclaimer

This product is not a toy, not intended for children under 14 years. Please put safety as a priority when using this product. Keep this product out of the reach of children.

If you are a novice pilot, please have an experienced pilot with you when you fly the aircraft.

Please read this manual carefully. Be sure you understand your legitimate rights, responsibility and the safety instructions. Improper operation may cause property loss, accidents and personal injury. You agree you have read, understood and accepted all the terms of this agreement. Keep in mind that your use of this product will be deemed acceptance of this agreement. You further declare that you shall be responsible for all the consequences arising out of or from unintended, malafide or misuses of this product or use of this product for any purpose other than the purpose stated by you. You have agreed to use this product for legitimate purposes and agree with this clause and any relevant policies or guidelines that we may formulate.

## IV. Technical Support

All products have been strictly checked and tested before coming into the market. Any new information or technology, we will update on the official website.

Users can contact the local retailer to seek for technical support or purchase additional spare parts.

## V. Know E01003

The EC1003 is a 5GHz UAV remote control for the company's DF series. Use this remote control to control the aircraft to achieve one-button take-off and landing, one-button return, switch flight mode, control on-board camera and camera.

EC1003 has built-in 18650 lithium battery, which has the characteristics of long use time, convenient charging and safe use.

### 1. About the Remote Controller

#### 1) Console

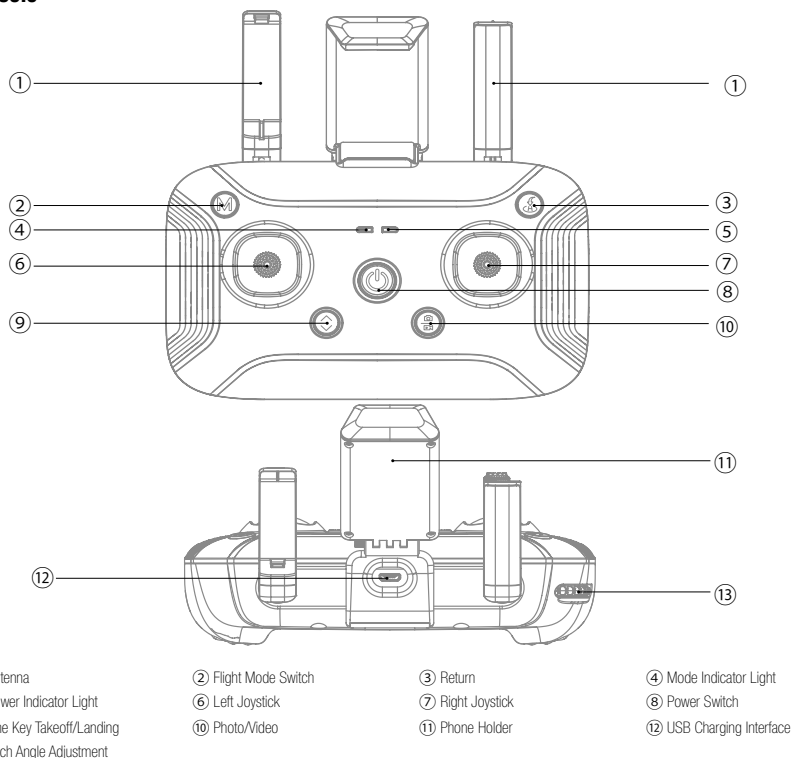





#### 2) Power indicator light

##### ○ Charging

Indicator Light		Status Indication
-----	Blinking green	Charging
 _____	Solid green	Charging completed



##### In operation

Indicator Light	Sound	Status Indication
_____	Null	Remote controller working normally.
 - - - - -	Beeps B-B-B	Low battery warning. Remote controller off.
 - - - - -	Beeps B-B-B	Critical low battery warning.

	_____	Solid red	Null	Error.
	- - - - -	Solid green	Beeps BB-BB-BB	Remote controller off if not in use for 5 minutes.



### 3) Mode status indicator light

	Indicator Light	Sound	Status Indication
	_____	No	Position Hold Mode
	_____	Null	Altitude Hold Mode



## 2. Battery charging for remote controller

Long press the power switch for 2 seconds to power on the remote controller. The indicator light turns solid green when the battery level is sufficient and turns blinking green when the battery level is low. To charge the battery, please comply with the following steps:

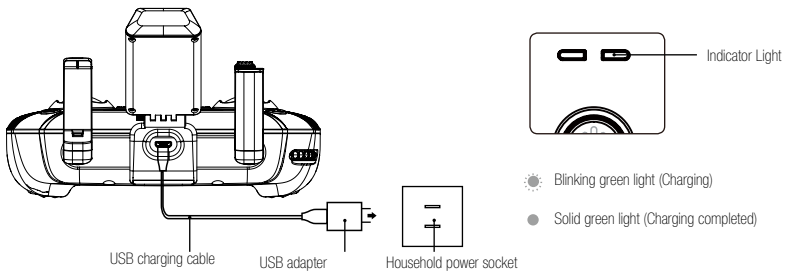

**Warning:** Disconnect the charging cable before using the remote controller.

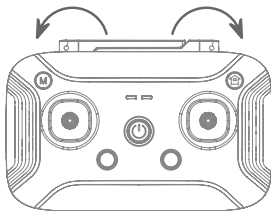

a. Stretch out the antenna.

### 3. Get

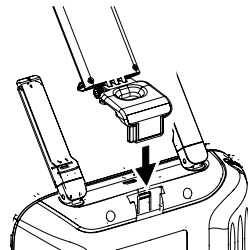

b. Insert the phone holder into the slot on the back of the remote controller.

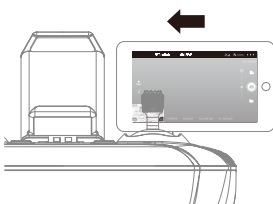

c. Mount the phone to the phone holder.

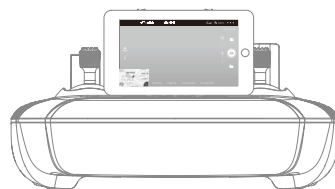

d. Adjust the phone and the antenna.

## the remote controller ready before flight

### 4. Switch Between Mode 1 and Mode 2

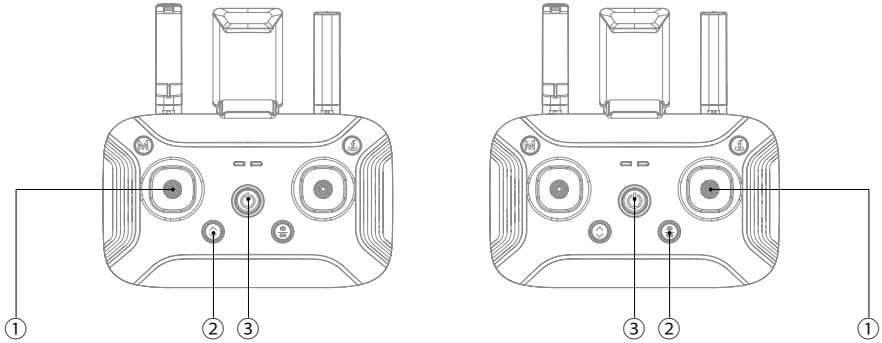

#### (1) Switch to Mode 2

Toggle the left joystick ① to the lowest position and press the "One Key Takeoff/ Landing" button ② at the same time. Then turn on the remote controller ③. Release the joystick ① and the button ② to enter Mode 2.

#### (2) Switch to Mode 1

Toggle the right joystick ① to the lowest position and press the "Photo/Video" button ② at the same time. Then turn on the remote controller ③. Release the joystick ① and the button ② to enter Mode 1.

## 5. Control via the Remote Controller

### 1) Power on the Remote Controller.

Long press the power switch "⏻" for 2 seconds to switch on the Remote Controller.

### 2) Power on the aircraft.

Long press the power switch for 2 seconds to switch on the aircraft.

Power on the aircraft and put it on a flat level surface for 30 seconds for self-checking. When the aircraft's indicator light turns from blinking or solid blue to blinking or solid green, the aircraft has successfully paired with the remote controller.

### 3) Take off

#### ○ Method 1: Manually control it to take off

When the aircraft's light turns from blue to green (as shown in the right picture), toggle the left and right joysticks outward for at least 3 seconds (as shown in the picture) as to get the propellers started to rotate.

Slowly toggle the throttle joystick upward to control the aircraft to take off quickly, and then toggle again to make it ascend slowly.

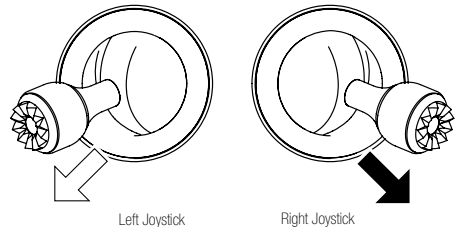

#### ○ Method 2: Press "◇" One Key Takeoff/ Landing to control it to take off

Long press the "◇" One Key Takeoff/ Landing button for 2 to 3 seconds. When the remote controller beeps continuously, the aircraft will automatically take off and ascend to the altitude of 1.2 meters and hover.

## 4) Land

Do not land near crowds of people or obstacles. Choose a wide open space as the landing site and control the drone to hover over the landing site before proceeding to make it land.

### ○ Method 1: Manually control it to land

Slowly toggle the throttle joystick to control the aircraft to land. When the aircraft lands on the ground, continue to toggle the joystick towards the lowest position until the propellers stop rotating.

### ○ Method 2: Press "◇" One Key Takeoff/ Landing to control it to land

Long press the "◇" One Key Takeoff/ Landing button for 2 to 3 seconds. When the remote controller beeps continuously, the aircraft will land vertically.

## 5) Joystick control

### (1) Mode 2 (Left joystick is the throttle joystick)

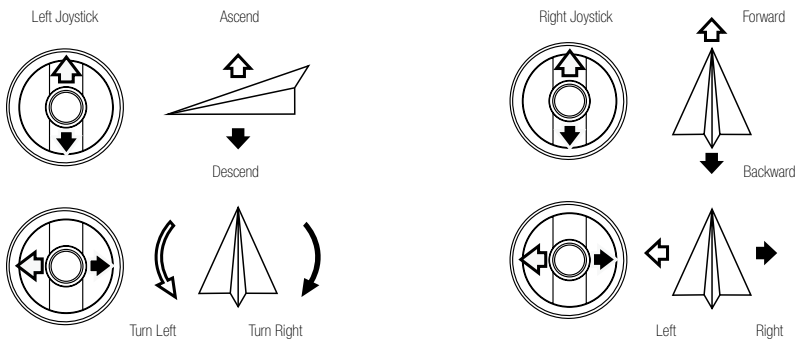

### (2) Mode 1 (Right joystick is the throttle joystick)

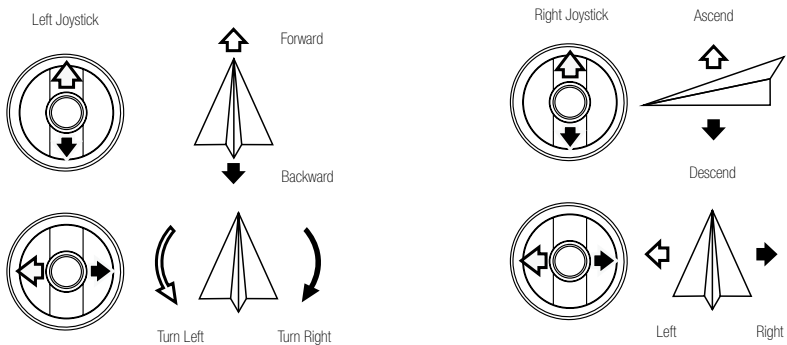



## 6. Photo and Video

During the flight, press the "Photo/ Video" button to take photos or videos.

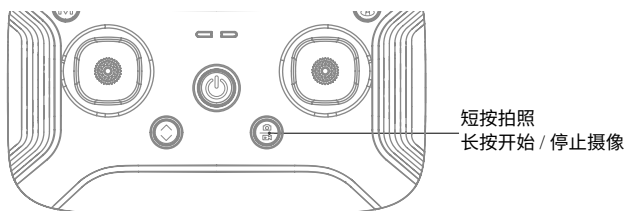

Short press the "📷" Photo/Video button. And the remote controller beeps, indicating that you have successfully taken a photo.

Long press the "📷" Photo/ Video button. And the remote controllers beeps B-B with the icon on the APP changing from white to red, indicating the camera has been ready for video shooting. Long press the button again. And the remote controller beeps B-B with the icon on the APP changing from red to white, indicating it has stopped recording.

## 7. Flight Mode

### 1) Position Hold Mode

#### ○ How to enter position hold mode

a. The drone will automatically enter position hold mode after start-up.

b. If the drone is in altitude hold mode and the GPS positioning system is working well, long press the "M" Flight Mode Switch button to switch to position hold mode.

#### ○ Status of the aircraft and the remote controller

The left indicator light on the controller turns solid green.

#### ○ Notice

In position hold mode, the aircraft will automatically locate its own position and hover steadily. Please choose a wide open space in the outdoor field, and wait until the GPS has been turned on before flying it.

### 2) Altitude Hold Mode

#### ○ How to enter altitude hold mode

If the aircraft is in position hold mode, long press the "M" Flight Mode Switch button to switch to altitude hold mode.

#### ○ Status of the aircraft and the remote controller

In this mode, the left indicator light on the controller turns solid red.

#### ○ Notice

The aircraft is more responsive and agile in altitude hold mode, which requires pilots with experienced operation skills. However, certain environmental factors, such as airflow, might affect the flight, resulting in drifting or hovering failure.

Please familiarize yourself with the position hold mode first and learn how to handle altitude hold mode before using it.

*Notes: As for the return to home point as precise as possible, please fly the aircraft in open flat terrain (no tall buildings in 50 meters of radius, flat terrain in 10 meters of radius) with the GPS working well. Thus the return to home function will be able to activate.*

## 8. Return To Home

In GPS positioning mode, you can press the "📶" One Key Return button to return the aircraft. Do not control any functions during the process of return or ascent. When the aircraft is landing, you can toggle the joystick to control it to land on your desired location. When the aircraft is returning to home point, long press the "📶" One Key Return button to exit auto return mode.

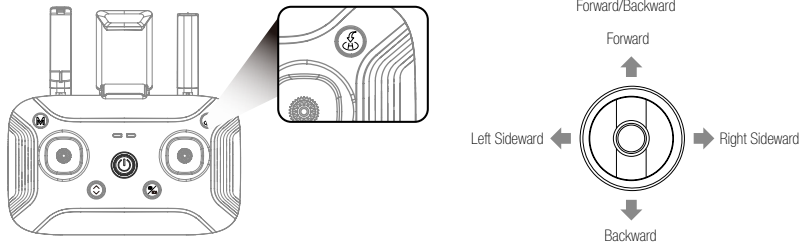

**Notes:** As for the return to home point as precise as possible, please ensure the GPS positioning function has been turned on (the aircraft's rear light turns solid green) to record the aircraft's position and choose an area away from obstacles before its takeoff.

With the GPS positioning mode turned on, it will automatically enter auto return to home mode if the remote controller loses control.

With the auto return to home mode enabled, if the aircraft flies below 30 meters of altitude, the aircraft will automatically ascend to 30 meters before returning to home point. However, if the aircraft flies over 30 meters of altitude, the aircraft will return to home point at the current altitude. Do not control other functions during the process of return. And ensure there are no obstacles in way of return to avoid accidents.

After the aircraft lands and the propellers stop rotating, long press the power switch for at least 2 seconds to turn off the aircraft and the remote controller.

**Warning:** Please stay away from aircraft until propellers stop rotating completely.

## 9. Pair the Aircraft with the Remote Controller

The aircraft has already paired with the remote controller by default. If the remote controller has been replaced, please pair again complying with the following steps:

- 1) Switch on the drone and the remote controller.
- 2) Unlock your mobile phone, enter the menu "Settings-WLAN" to view the Wi-Fi network list, among which you can see "Drone-xxxxx" (xxxxx consists of characters and numbers) of the drone and "Controller-xxxxx" of the remote controller (xxxxx consists of characters and numbers). Please take down the serial number of the remote controller for further reference.
- 3) Click the Wi-Fi network of the drone to connect.
- 4) Enter the APP interface and click "." in the top right corner to enter the menu.
- 5) Find "RC Paired" and click "Pair".
- 6) A dialogue box will pop up. Type in the serial number of the remote controller in the box and click "Pair" to confirm.
- 7) Navigate your mobile phone to "Settings-WLAN" again to check the serial numbers of the drone and the remote controller. If the two serial numbers are correct, the pairing will be successful, with the drone's rear lights turning flashing green or solid green.

# C-Fly Technical Support

Dear Customer,

Thank you for choosing C-Fly product. Please visit C-Fly official website for more FAQ and information. If there is any problem of using our product.

Product Operation: Please visit C-Fly College for tutorial video or user manual.

Product Features: Please refer to product page description or product brochure.

After-sale Service: Please refer to conditions and terms of after-sale service. The final interpretation right belongs to all C-Fly .

Should you have any further questions, please visit C-Fly Online Feedback and leave your message.

Thank you again for your support!

ShenZhen C-Fly TECHNOLOGY CO.,LTD.

<http://www.cfly-cn.com/>

## Warming:

changes or modifications not expressly approved by the party responsible for compliance could void the user's authority to operate the equipment.

This device complies with Part 15 of the FCC Rules. Operation is subject to the following two conditions: (1) this device may not cause harmful interference, and (2) this device must accept any interference received, including interference that may cause undesired operation.

This equipment has been tested and found to comply with the limits for a Class B digital device, pursuant to Part 15 of the FCC Rules. These limits are designed to provide reasonable protection against harmful interference in a residential installation. This equipment generates, uses and can radiate radio frequency energy and, if not installed and used in accordance with the instructions, may cause harmful interference to radio communications. However, there is no guarantee that interference will not occur in a particular installation. If this equipment does cause harmful interference to radio or television reception, which can be determined by turning the equipment off and on, the user is encouraged to try to correct the interference by one or more of the following measures:

- Reorient or relocate the receiving antenna.
- Increase the separation between the equipment and receiver.
- Connect the equipment into an outlet on a circuit different from that to which the receiver is connected.
- Consult the dealer or an experienced radio/TV technician for help.

This equipment complies with FCC radiation exposure limits set forth for an uncontrolled environment. This equipment should be installed and operated with a minimum distance of 20cm between the radiator & your body. This transmitter must not be co-located or operating in conjunction with any other antenna or transmitter.